



## **Identiv Connected Physical Access Manager 2.2 User Guide**

September 12, 2016

**Identiv, Inc.**  
[www.identiv.com](http://www.identiv.com)

Copyright © 2015-2016 Identiv, Inc. All rights reserved.

Identiv  
2201 Walnut Ave., Suite 100  
Fremont, CA 94538

Phone: (949) 250-8888  
Fax: (949) 250-7372  
Web: [www.identiv.com](http://www.identiv.com)

Identiv and the Identiv logo are trademarks or registered trademarks of Identiv and/or its affiliates in the U.S. and other countries. To view a list of Identiv trademarks, go to this URL: <http://www.identiv.com/legal>.

Any Internet Protocol (IP) addresses and phone numbers used in this document are not intended to be actual addresses and phone numbers. Any examples, command display output, network topology diagrams, and other figures included in the document are shown for illustrative purposes only. Any use of actual IP addresses or phone numbers in illustrative content is unintentional and coincidental.

THE SPECIFICATIONS AND INFORMATION REGARDING THE PRODUCTS IN THIS MANUAL ARE SUBJECT TO CHANGE WITHOUT NOTICE. ALL STATEMENTS, INFORMATION, AND RECOMMENDATIONS IN THIS MANUAL ARE BELIEVED TO BE ACCURATE BUT ARE PRESENTED WITHOUT WARRANTY OF ANY KIND, EXPRESS OR IMPLIED. USERS MUST TAKE FULL RESPONSIBILITY FOR THEIR APPLICATION OF ANY PRODUCTS.

THE SOFTWARE LICENSE AND LIMITED WARRANTY FOR THE ACCOMPANYING PRODUCT ARE SET FORTH IN THE INFORMATION PACKET THAT SHIPPED WITH THE PRODUCT AND ARE INCORPORATED HEREIN BY THIS REFERENCE. IF YOU ARE UNABLE TO LOCATE THE SOFTWARE LICENSE OR LIMITED WARRANTY, CONTACT YOUR IDENTIV REPRESENTATIVE FOR A COPY.

The implementation of TCP header compression in this product is an adaptation of a program developed by the University of California, Berkeley (UCB) as part of UCB's public domain version of the UNIX operating system. All rights reserved. Copyright © 1981, Regents of the University of California.

NOTWITHSTANDING ANY OTHER WARRANTY HEREIN, ALL DOCUMENT FILES AND SOFTWARE OF THESE SUPPLIERS ARE PROVIDED "AS IS" WITH ALL FAULTS. IDENTIV AND THE ABOVE-NAMED SUPPLIERS DISCLAIM ALL WARRANTIES, EXPRESSED OR IMPLIED, INCLUDING, WITHOUT LIMITATION, THOSE OF MERCHANTABILITY, FITNESS FOR A PARTICULAR PURPOSE AND NONINFRINGEMENT OR ARISING FROM A COURSE OF DEALING, USAGE, OR TRADE PRACTICE.

IN NO EVENT SHALL IDENTIV OR ITS SUPPLIERS BE LIABLE FOR ANY INDIRECT, SPECIAL, CONSEQUENTIAL, OR INCIDENTAL DAMAGES, INCLUDING, WITHOUT LIMITATION, LOST PROFITS OR LOSS OR DAMAGE TO DATA ARISING OUT OF THE USE OR INABILITY TO USE THIS MANUAL, EVEN IF IDENTIV OR ITS SUPPLIERS HAVE BEEN ADVISED OF THE POSSIBILITY OF SUCH DAMAGES.

Identiv and the Identiv logo are trademarks or registered trademarks of Identiv and/or its affiliates in the U.S. and other countries. Third-party trademarks mentioned are the property of their respective owners. The use of the word partner does not imply a partnership relationship between Identiv and any other company. (1110R)

Copyright © 2016 Identiv, Inc. All rights reserved.

## Revision History

<b>Text Part Number</b>	<b>Date Published</b>	<b>Description</b>
IC01-02	September 12, 2016	Corresponds to the ICPAM 2.2 release, which includes bug fixes and adds support for: the optional Exit Reader Expansion Module for EM-100 controllers; anti-passback for EM-100 controllers; and the "Reset All Card Holder Status" right-click command for the Identiv EM-100 Driver. This version of the document also includes numerous technical corrections and editorial improvements.
IC01-01	February 1, 2016	Corresponds to the ICPAM 2.1 release, which adds support for Identiv's EM-100 single-door controller.



- Preface**    **xix**
  - Obtaining Documentation and Submitting a Service Request    **xix**
  - Safety Warnings    **xix**
  - Safety Guidelines    **xxii**
    - General Precautions    **xxii**
    - Protecting Against Electrostatic Discharge    **xxiii**
    - Rack Installation Safety Guidelines    **xxiii**
  
- Overview**    **1-1**
  - Overview: ICPAM Physical Device Connections    **1-2**
  - Installation and Configuration Summary    **1-3**
    - Install the Cisco Gateway Hardware and Software Components    **1-3**
    - Install the EM-100 Controller Hardware and Software Components    **1-4**
    - Configure Doors and Users in ICPAM    **1-5**
  - ICPAM Installation and Configuration Flowchart    **1-10**
  - System Recovery    **1-12**
  - User Guide Contents    **1-13**
  - ICPAM Software Overview    **1-14**
    - ICPAM Desktop Client Software    **1-15**
    - ICPAM Server Administration Utility    **1-16**
    - Controller or Gateway Administration Utility    **1-16**
    - The Enterprise Data Integration (EDI) Desktop Studio    **1-18**
    - Cisco Video Surveillance    **1-18**
    - Badge Designer    **1-19**
  
- Configuring and Monitoring the ICPAM Server**    **2-1**
  - Overview    **2-2**
    - About the ICPAM Server Administration Utility    **2-2**
    - Logging on to the ICPAM Server Administration Utility    **2-2**
    - Using Redundant Appliances for High Availability    **2-2**
    - Understanding IP Addresses on the ICPAM Server    **2-3**
      - ICPAM Appliance IP Addresses    **2-3**
        - Eth0 Port IP Address    **2-3**
        - Shared IP Address    **2-3**

Eth1 Port IP address	2-4
Upgrading a Single Standalone Server to an HA Configuration	2-4
Controller and Gateway Module IP Addresses	2-4
Entering the Initial Server Configuration	2-5
Before You Begin	2-5
Connecting a PC to the Appliance	2-5
Initial Setup Instructions	2-7
Configuring ICPAM on a Virtual Machine (VM)	2-17
Before You Begin	2-17
Configuration Procedure	2-18
Using the Web Admin Menus, Commands, and Options	2-19
Accessing the ICPAM Server Administration Utility	2-19
Menus and Options in the ICPAM Server Administration Utility	2-20
Monitoring	2-21
Setup	2-22
Commands	2-23
Launch Client	2-24
Downloads	2-24
Archiving Historical Events	2-25
Understanding Live, Pruned, and Archived Events	2-25
Live Events	2-25
Pruned Events	2-25
Archived Events	2-26
Pruning and Archiving Historical Events	2-26
Installing and Revising Language Packs	2-30
Usage Notes	2-30
Creating or Revising a Language Pack	2-30
Changing or Recovering the Server Password	2-40
Changing the ICPAM Server Administration Utility Password	2-40
Resetting a Forgotten Password	2-41
Enabling the <i>Forgot Password</i> Feature	2-42
Recovering a Lost Server Password	2-44
Obtaining and Installing Optional Feature Licenses	2-45
Licenses in a Redundant Configuration	2-45
Part Numbers for the Optional Feature Licenses	2-46
Installing Additional Licenses	2-46
Displaying a Summary of Installed Licenses	2-47
Displaying the ICPAM Appliance Serial Number	2-48
Performing a Graceful Failover with Redundant Appliances	2-49
Troubleshooting and Monitoring	2-49

Next Steps	2-49
<b>Getting Started With the ICPAM Desktop Software</b>	<b>3-1</b>
Before You Begin	3-2
Installing or Updating the ICPAM Desktop Software	3-2
Logging into the ICPAM Client	3-3
Understanding the Start Page and Window Management	3-4
Keeping a Module On Top	3-6
Choosing Multiple <i>Always on Top</i> Windows	3-7
Deselecting <i>Always on Top</i>	3-7
User Interface Elements	3-8
Toolbar Features	3-10
Creating Reports	3-10
Using Filters	3-12
Filter Creation Example	3-12
Revising the Column Display	3-14
Using Group Edit	3-14
Group Edit Example	3-14
Search	3-15
<b>Configuring User Access for the ICPAM Desktop Client</b>	<b>4-1</b>
Defining User Profiles for Desktop Application Access	4-1
Creating User Login Accounts and Assigning Profiles	4-9
Additional Information	4-13
Configuring LDAP User Authentication	4-14
Configure the LDAP Server	4-14
LDAP Example: User Principal Name	4-16
LDAP Example: sAMAccountName	4-17
Create the LDAP User Account in ICPAM	4-18
Viewing Audit Records for Changes to Usernames	4-19
Managing Desktop Client Passwords	4-21
Changing Your Password	4-21
Changing Another User's Password	4-21
Managing the <i>cpamadmin</i> Login and Password	4-21
<b>Understanding Controller and Door Configurations</b>	<b>5-1</b>
Provisioned (Pre-Populated) vs. Discovered Controller Configurations	5-2
Provisioned (Pre-Populated) Configuration	5-2
Discovered Configuration	5-2

Viewing Device and Door Configuration	5-3
Viewing Doors and Devices in the Hardware Tree View	5-4
Hardware Manager in ICPAM 2.1	5-6
Viewing Doors and Devices by Location	5-7
Creating the Location Map	5-8
Changing the Location of a Device or Door	5-9
Location-Restricted User Permissions	5-10
Viewing Device and Door Status	5-11
Viewing a Status Summary for All Devices	5-11
Viewing the Status for a Single Door, Device, or Driver	5-13
Understanding Device Status Colors	5-15
Monitoring Device Errors	5-16
Viewing the Recent Events for a Device or Driver	5-17
Generating a Gateway Driver System Sanity Report	5-18
Understanding Door Configurations and Templates	5-23
Overview	5-23
Sequence for Configuring Templates and Doors	5-24
Door Configurations and Templates	5-24
Template Types	5-25
Impact of Template Changes on Configured Doors and Devices	5-26
Gateway Templates	5-26
Controller Templates	5-26
Understanding Door Templates	5-26
Understanding Device Templates	5-27
Understanding Virtual Credential Templates	5-27
Understanding Gateway Credential Templates	5-28
Understanding Reader LED Profiles	5-28
Understanding Door Modes, Door Schedules, and the First Unlock Feature	5-28
Overview	5-29
Understanding Door Modes	5-30
Viewing the Door Mode Status	5-31
Understanding the Default Door Mode	5-31
Understanding the Scheduled Door Mode	5-31
Understanding First Unlock Impact on the Scheduled Mode	5-32
Manually Override the Door Mode Using Commands	5-32
Impact of Controller Reset on the Default and Scheduled Modes	5-34
Example 1	5-34
Example 2	5-34
Understanding Door Schedule Entries in ICPAM 2.1	5-35
Configuring the Default and Scheduled Door Modes	5-36

Locating Serial Numbers	5-40
Locating Controller and Expansion Module Serial Numbers	5-40
Displaying the ICPAM Appliance Serial Number	5-40
<b>Configuring Controllers</b>	<b>6-1</b>
Configuring New Controllers	6-1
Creating Custom Gateway Configurations without Templates	6-2
Configuring Gateways Using Existing Templates	6-7
Creating Custom EM-100 Controller Configurations without Templates	6-15
Configuring EM-100 Controllers Using Existing Templates	6-18
Adding a Standard EM-100 Controller (with Only an Entry Reader)	6-18
Adding an EM-100 Controller with an Exit Reader Expansion Module	6-25
Configuring an EM-100 Controller with the Desired Access Mode	6-33
Configuring an EM-100 Controller for Access Using Only a PIN Code	6-33
Configuring an EM-100 Controller for Access Using a Card and a PIN Code	6-38
Modifying Existing Controllers	6-42
Editing Gateway Controllers	6-42
Editing Identiv EM-100 Controllers	6-42
Gateway Controller Property Sheets	6-43
Gateway General Property Page	6-43
Gateway Location Property Sheet	6-44
Gateway Properties Property Sheet	6-45
EM-100 Controller Property Sheets	6-46
Controller General Property Page	6-46
Controller Location Property Page	6-47
Controller Configuration Page	6-47
Controller Calendar and Time Zone Page	6-48
Controller Audit Records Page	6-49
Controller Recent Events Page	6-49
Controller Device Commands	6-50
Applying Configuration Changes	6-50
Applying Configuration Changes to Controllers	6-50
Applying Configuration Changes in the Hardware Tree Module	6-50
Applying Configuration Changes in the Door/Location-Based Module	6-52
Configuration Management in Provisioned vs. Discovered Configurations	6-53
Cloning a Gateway Configuration	6-53
Replacing a Gateway	6-54
Deleting a Controller	6-55
Changing Gateway Passwords	6-55

Modifying Driver Configurations	6-58
Modifying GW Drivers	6-58
Modifying Identiv EM-100 Drivers	6-58
Access GW Driver Property Sheets	6-59
Gateway Driver General Page	6-59
Gateway Driver Location Property Page	6-60
Gateway Driver Configuration Property Page	6-61
Gateway Driver Recent Events Property Sheet	6-61
Identiv EM-100 Driver Property Sheets	6-62
Driver General Page	6-62
Driver Location Property Page	6-63
Driver Configuration Page	6-64
Driver EM-100 Credential Templates Page	6-65
Driver Input Supervision Page	6-66
Driver Audit Records Page	6-66
Driver Recent Events Page	6-67
Controller and Driver Commands	6-68
Access GW Driver Commands	6-68
Gateway Controller Commands	6-69
Physical Driver Commands	6-71
Identiv EM-100 Driver Commands	6-71
<b>Configuring Doors</b>	<b>7-1</b>
Adding New Doors	7-2
Adding Custom Doors	7-2
Adding Doors Using Door Templates	7-3
Modifying Door Configurations	7-11
Modifying Doors and Devices in the Hardware Tree View	7-12
Modifying Devices in the Door/Location-based Hardware Module	7-13
Applying Configuration Changes	7-14
Applying Configuration Changes to Controllers	7-14
Applying Configuration Changes in the Hardware Tree Module	7-14
Applying Configuration Changes in the Door/Location-based Hardware Module	7-15
Configuration Management in Provisioned vs. Discovered Configurations	7-16
Disabling or Deleting a Door	7-16
Disabling a Device or Door	7-16
Deleting Devices and Doors	7-18
Enabling the Delete Options	7-18
Deleting a Device	7-20
Enabling a Device or Door	7-20
Disable and Enable a Device and Door: Example	7-20



Configuring Device Groups	7-24
Device Groups in ICPAM 2.1	7-24
Adding an Expansion Module in an Existing Setup	7-28
Auto-Discover	7-28
Provision Mode	7-28
Replacing an Expansion Module for a Gateway	7-28
Adding an Exit Reader to the Door of an EM-100 Controller	7-29
Door Property Sheets	7-31
General Door Property Sheet	7-33
Location Door Property Sheet	7-34
Associate Devices Door Property Sheet	7-34
Properties Door Property Sheet	7-35
Usage Profiles Door Property Sheet	7-37
Facility Code Door Property Sheet	7-38
Duress Specifications Door Property Sheet	7-39
Door Groups Door Property Sheet	7-39
Door Door Property Sheet	7-40
Hardware Rules Door Property Sheet	7-42
Audit Records Door Property Sheet	7-43
Recent Events Door Property Sheet	7-44
Device Commands Door Property Sheet	7-44
Device Commands	7-46
Reader Module Commands	7-46
Input and Output Module Commands	7-47
Door Modes and Commands	7-47
Door Modes	7-47
Door Commands	7-48
<b>Configuring Door and Device Templates</b>	<b>8-1</b>
Configuring Door Templates	8-2
Configuring Device Templates	8-11
Creating a Device Template	8-11
Configuring Credential Templates	8-15
Overview	8-15
Credential Templates Settings Summary	8-17
Wiegand Keypad	8-17
Wiegand	8-17
Keypad	8-17
Creating a Gateway Credential Template	8-18

- Creating a Virtual Credential Template 8-20
      - Importing New Credential Templates from VFF Files 8-23
  - Configuring Reader LED Profiles 8-24
    - Configuring Reader LED and Buzzer Profiles 8-24
  - Duplicating Templates 8-26
    - Duplicating Door, Device, and Credential Templates 8-26
    - Duplicating Gateway Templates 8-27
  - Door Configuration Properties 8-28
  - Device Configuration Properties 8-30
    - Understanding Normally Open vs. Normally Closed Devices 8-30
    - Understanding Supervised vs. Unsupervised Input Devices 8-30
    - Device Configuration Properties Summary 8-31
  - Debounce Timer 8-35
- Configuring Personnel and Badges 9-1**
  - Configuring Personnel 9-2
  - Downloading Credential Changes to the Controllers 9-9
  - Viewing Audit Records and Events for Personnel Records 9-10
    - Viewing Audit Records 9-10
    - Viewing Recent Events 9-11
  - Editing Organization and Department Lists 9-12
  - Importing Personnel Records Using a Comma Separated Value (CSV) File 9-14
    - Before You Begin 9-14
  - Using a SnapShell License Scanner to Create Personnel Records 9-19
    - Install and Configure the SnapShell Scanner 9-19
    - Scan a License to Create a New Personnel Record 9-23
  - Configuring Badges 9-24
  - Configuring Badge Templates 9-25
    - Badge Properties 9-26
      - Badges module: General page 9-27
      - Credential Validity Types 9-29
    - Badges module: Access Policies page 9-30
    - Badges module: Advanced page 9-31
    - Badges module: Advanced Gateway page 9-32
    - Badges module: Advanced EM-100 page 9-33
    - Badges module: HSPD-12 Badge Extension page 9-34
    - Badges module: Audit Records page 9-35
    - Badges module: Recent Events page 9-35

Badge Authentication	9-36
Usage Notes	9-36
Limitations	9-37
Using the Badge Designer	9-38
Installing and Using a Barcode Font	9-45
Printing Badges	9-48
List of Recommended Badge Printers	9-49
Printing Individual Badges	9-50
Printing Multiple Badges	9-51
Printing High Resolution Images	9-55
Changing the Default Badge Printer	9-56
System Configuration Settings for Badge Printing	9-57
Setting Up Image and Signature Options for Personnel Records	9-59
Enabling Image Capture Devices	9-59
Enabling Signature Capture Devices	9-61
<b>Multifactor Authentication</b>	<b>10-1</b>
Configuring Generic Readers	10-1
Associating Generic Readers with Doors	10-3
Additional Information	10-6
<b>Configuring ICPAM Access Policies</b>	<b>11-1</b>
Configuring Access Policies	11-2
Access Policies in ICPAM 2.1	11-5
Managing Door Access With Access Policies	11-6
Using the Schedule Manager	11-9
Schedule Manager in ICPAM 2.1	11-12
Modifying Types and Time Ranges	11-13
Modifying Work Weeks	11-14
Modifying Holidays	11-15
Time Ranges	11-16
Modifying Special Cases	11-17
Time Entry Collections	11-18
Creating and Managing Anti-Passback Areas	11-19
Impact of the Profile Enhancement Feature on Anti-Passback Areas	11-20
Limitations of Anti-Passback Areas	11-21
Configuring Anti-Passback Areas	11-22
Using Local (Controller) Credentials if Network Communication is Lost	11-24
Evicting a Badge from APB if the User Does Not Enter the APB Area	11-26
Resetting the Status of All Card Holders (at Online EM-100 Controllers)	11-29

Monitoring Anti-Passback Events	11-30
Anti-Passback Events Displayed in the Events Module	11-31
Two-Door Policies	11-31
Two-Door Policies in ICPAM 2.1	11-31
Configuring Two-Door Policies	11-31
Two-Door State Monitoring	11-34
<b>Events &amp; Alarms</b>	<b>12-1</b>
Viewing Events, Alarms, and Audit Trail Records	12-2
Events and Alarms in ICPAM 2.1	12-3
Understanding Live and Archived Events	12-3
Understanding Event Timestamps	12-3
Viewing Events	12-3
Viewing Alarms	12-8
Alarms Main Window	12-8
Alarm States	12-9
Alarm Detail Window	12-10
Alarm Properties	12-10
Alarm Comments	12-12
Alarm Instructions - Creating	12-13
Alarm Instructions - Viewing	12-19
Viewing Audit Trail Records	12-20
Viewing Recent Events for a Device, Driver, or Location	12-23
Viewing Events Using Personnel Photos	12-24
Viewing Event Photos	12-24
Adding a Color Border to Event Photos (Credential Watch)	12-25
Using Filters to Limit the Photos and Doors Events Displayed by Event Photos	12-29
Recording External Events	12-33
Define External Event Types Using the Event Definition Format	12-33
Create a Text File to Define the Event Names in ICPAM	12-34
Import the Files into ICPAM	12-34
Viewing Workstation Activity	12-36
Configuring Events and Alarms	12-37
Modifying Default Event Policies	12-37
Configuring Custom Event Policies	12-38
Event Policy Manager in ICPAM 2.1	12-38
Event Policy Properties	12-40
Automatically Open the Alarms Window	12-42
Configuring Time Schedules	12-43

Configuring Alert Sounds	12-46
Setting Event and Alarm Priorities	12-47
Defining User Privileges for Editing Events	12-48
Using Graphic Maps	12-49
Graphic Maps in ICPAM 2.1	12-49
Maps Viewer	12-50
Icon Colors and Status	12-51
Device Commands	12-53
Layers and Views	12-53
Toolbar and Navigation Controls	12-54
Map Editor	12-55
Backing Up and Archiving Events	12-63
Including Events In System Backups	12-63
Pruning and Archiving Old Events	12-63
Creating Reports from Pruned Events	12-64
<b>Configuring Automated Tasks</b>	<b>13-1</b>
Creating Quick Launch Buttons	13-2
Creating a Button	13-2
Creating a Button That Runs An Automated Rule	13-8
Creating Panels (Windows) of Related Buttons	13-9
Restricting User Access to Button Panels	13-10
Using Quick Launch Buttons	13-11
Configuring Edge Policies	13-11
Configuring Device I/O Rules	13-16
Configuring Global I/O Automated Rules	13-18
Enabling the Automation Driver	13-18
Configuring Automated Tasks Using Global I/O	13-20
Understanding Automated Rule Actions	13-23
Global I/O Example: Automated Weekly Report	13-29
Automation Rules in ICPAM 2.1	13-33
Defining Reports (Report Manager)	13-36
Report Manager in ICPAM 2.1	13-36
Using the Report Manager	13-37
Filter-based Report Template	13-38
Object SQL-based Report Template	13-40
SQL-Based Report Template	13-41
Additional Information	13-42

<b>System Integration</b>	<b>14-1</b>
Configuring URL Actions	14-2
Creating or Modifying URL Actions	14-3
Creating Automated Rules for URL Actions	14-5
Viewing URL Events, Alarms, and Logs	14-7
Viewing URL Action Events	14-7
Viewing Alarms for Failed URL Actions	14-8
Event and Alarm Response Codes for URL Actions	14-8
Viewing Logs for URL Action Output	14-9
URL Action Failure Due to Invalid Security Certificate	14-10
Synchronizing Data Using Enterprise Data Integration (EDI)	14-11
Before You Begin	14-11
Understanding Photo File Compression When Importing Personnel Records	14-12
Installing the EDI License and Desktop Application	14-13
Creating Active Directory Database Integration Projects Using EDI Studio	14-16
Creating Custom Employee Status Values	14-26
Creating SQL and Oracle Database Integration Projects Using EDI Studio	14-28
EDI Project Data Field Mapping	14-34
Importing and Associating Badges to Corresponding Personnel Automatically	14-38
Importing, Starting, and Monitoring EDI Projects in ICPAM	14-40
Importing and Starting EDI Projects	14-40
Verifying EDI Projects (EDI Monitoring)	14-42
Modifying a Running EDI Project	14-45
Restarting a Failed EDI Project	14-47
Resolving Active Directory Issues	14-47
Resolving ICPAM or EDI Studio Issues	14-47
Summary of EDI Administration Functions	14-47
Column Descriptions	14-47
EDI Administration Functions	14-48
Accessing the SQL Database	14-49
Personnel view	14-50
Time and Attendance view	14-51
User Tracking view	14-52
<b>Video Monitoring</b>	<b>15-1</b>
Camera Manager in ICPAM	15-1
Enabling Video Monitoring	15-2
Configuring the Camera Driver	15-3
Associating Cameras with Doors and Devices	15-7
PC Workstation Requirements for Live Video Viewing	15-11

Installing the <i>Cisco VSOM Video Client</i> Desktop Application	15-11
Viewing Video	15-13
Viewing Live Video in a Grid Arrangement	15-14
Camera Grid Editor	15-16
Viewing Video for an Event	15-21
Viewing Event Video on a VSM Camera Driver 7X	15-22
Defining the Duration of Event Video Recording	15-25
Managing the Camera Inventory	15-27
Updating the Camera Inventory	15-27
Deleting the Cisco VSM Cameras	15-29
Deleting Individual Cameras	15-33
Recording Motion Events from Cisco VSM Cameras	15-35
Triggering Camera Actions and Video Recording in Cisco VSM	15-40
<b>VoIP Integration</b>	16-1
Creating a Phone Service in UCM	16-2
Additional Information	16-4
More Information about the URLs	16-5
Subscribing a service to a VoIP Phone	16-5
Procedure	16-5
Limitations	16-12
<b>System Configuration Settings</b>	17-1
LDAP page of the System Configuration window	17-3
Event/Alarms page of the System Configuration window	17-5
Personnel page of the System Configuration window	17-7
Badges page of the System Configuration window	17-9
Logins page of the System Configuration window	17-11
Password Policy page of the System Configuration window	17-13
Personnel - Custom page of the System Configuration window	17-14
Custom Field Tabs	17-16
Devices - Custom page of the System Configuration window	17-17
Badges - Custom page of the System Configuration window	17-19
ID Number Generator page of the System Configuration window	17-21
PIN Generator page of the System Configuration window	17-22
Card Number Generator page of the System Configuration window	17-23
Support Contact page of the System Configuration window	17-25
Badge Designer page of the System Configuration window	17-26

Badge Printing page of the System Configuration window 17-28

Image Processing page of the System Configuration window 17-30

Miscellaneous page of the System Configuration window 17-32

Temporary Badge Wizard page of the System Configuration window 17-34

General UI page of the System Configuration window 17-36

Advanced page of the System Configuration window 17-37

Identiv page of the System Configuration window 17-40

HSPD-12 page of the System Configuration window 17-41

**Backing Up and Restoring Data A-1**

Backing up the ICPAM Database A-2

    Backup Usage Notes A-2

    Scheduling Automatic Backups A-3

    Disabling Automatic Backups A-6

    Performing a One-Time Manual Backup A-7

Archiving the Historical Events Database A-9

Restoring a Server Backup File A-9

**Upgrading the Server Software B-1**

Upgrade Notes for Release 2.1 B-2

    Event Archive Settings Are Required B-3

    Localization Feature Requires Database Upgrade B-4

    Controller Firmware Must Be the Same Version as ICPAM B-4

    Credential Download Frequency Must be 60 Minutes or Higher B-5

    Door Groups Feature Added to Device Groups B-5

    Enabling the Password Recovery Feature B-5

    Upgrading From CPAM Release 1.3.0 to ICPAM Release 2.1 B-5

    Split Holiday Schedule Configurations By Month B-6

    Select the Following Options When Upgrading Gateway Firmware B-6

    Generic Output Devices Installed Prior to Release 1.1.0 Must Be Rewired B-6

        Required Generic Output Device Connections in CPAM Release 1.1.0 B-6

    Generic Output Device Command and Event Name Changes B-7

    Browser Time-out B-7

    Upgrade the ICPAM Desktop Client Software B-7

    Java Requirements B-7

    Stop EDI Projects Before Upgrading ICPAM B-7

    Change the Database Password Message B-8

Obtaining Software Images B-8

Obtaining Release Notes and Other Related Documentation B-10



Upgrading the ICPAM Desktop Software	B-10
Upgrading the ICPAM Server Software	B-11
Replacing an Appliance	B-20
Replacing a Stand-Alone (Non-Redundant) Appliance	B-20
Replacing Both Appliances in an HA Configuration	B-21
Replacing a Single Appliance in an HA Configuration	B-22
Reinstalling the ICPAM Server Software from a Recovery CD	B-24
<b>Upgrading and Configuring Gateways</b>	<b>C-1</b>
Displaying the Gateway Network and Firmware Configuration	C-2
Changing the Gateway Network Settings	C-3
Changing the NTP Setting for Multiple Gateways	C-6
(Optional) Set a Default NTP Server	C-6
Change the NTP Setting for Multiple Gateways	C-8
Using Door/Location-based Hardware to Change Gateway Network Settings	C-10
Upgrading Gateway Firmware Images Using ICPAM	C-11
Uploading Firmware Images to a TFTP Server	C-11
Updating the Firmware on All Gateways	C-15
Updating the Firmware on Individual Gateways	C-21
Gateway Firmware Backward Compatibility	26
<b>Security</b>	<b>D-1</b>
ICPAM TCP Port Requirements for Firewall Connections	D-1
Disabling the ICPAM TFTP Server	D-2
Related Security Documentation	D-3
<b>Troubleshooting</b>	<b>E-1</b>
Licensing: Frequently Asked Questions	E-1
<b>Related Documentation</b>	<b>F-1</b>
Physical Access Control User Documentation	F-1
Cisco Video Surveillance Manager (Cisco VSM) User Documentation	F-1
Cisco IP Interoperability and Collaboration System (IPICS) Documentation	F-2
Related Security Documentation	F-2
<b>GLOSSARY</b>	<b>G-1</b>
<b>INDEX</b>	<b>I-1</b>





# Preface

---

- [Obtaining Documentation and Submitting a Service Request](#), page xix
- [Safety Warnings](#), page xix
- [Safety Guidelines](#), page xxii

## Obtaining Documentation and Submitting a Service Request

For information about obtaining documentation, submitting a service request, and gathering additional information, you can e-mail Identiv technical support at:

support\_icpam@identiv.com

or consult the Identiv website at:

<http://www.identiv.com/support-icpam>

For information about credential templates, refer to:

<http://www.identiv.com/icpam-credential-templates>

## Safety Warnings

Before you install the device, observe the safety warnings in this section.

  
Warning

---

**Read the installation instructions before connecting the system to the power source.** Statement 1004

---

  
Warning

---

**Before working on a system that has an on/off switch, turn OFF the power and unplug the power cord.** Statement 1

---

  
Warning

---

**Before working on a chassis or working near power supplies, unplug the power cord on AC units; disconnect the power at the circuit breaker on DC units.** Statement 12

---



**Warning**

**This unit might have more than one power cord. To reduce the risk of electrical shock, disconnect all power supply cords before servicing the unit.** Statement 106



**Warning**

**This is a Class A Information Product, when used in residential environment, it may cause radio frequency interference, under such circumstances, the user may be requested to take appropriate countermeasures.** Statement 257



**Warning**

**Do not attempt to make such connections yourself. Contact the appropriate electric inspection authority or electrician as appropriate.** Statement 285



**Warning**

**Do not work on the system or connect or disconnect cables during periods of lightning activity.** Statement 1001



**Warning**

**To prevent bodily injury when mounting or servicing this unit in a rack, you must take special precautions to ensure that the system remains stable. The following guidelines are provided to ensure your safety:**



**Warning**

**This unit should be mounted at the bottom of the rack if it is the only unit in the rack.**



**Warning**

**When mounting this unit in a partially filled rack, load the rack from the bottom to the top with the heaviest component at the bottom of the rack.**



**Warning**

**If the rack is provided with stabilizing devices, install the stabilizers before mounting or servicing the unit in the rack.** Statement 1006



**Warning**

**There is the danger of explosion if the battery is replaced incorrectly. Replace the battery only with the same or equivalent type recommended by the manufacturer. Dispose of used batteries according to the manufacturer's instructions.** Statement 1015



**Warning**

**This unit is intended for installation in restricted access areas. A restricted access area can be accessed only through the use of a special tool, lock and key, or other means of security.** Statement 1017

---

 **Warning** **This equipment must be grounded. Never defeat the ground conductor or operate the equipment in the absence of a suitably installed ground conductor. Contact the appropriate electrical inspection authority or an electrician if you are uncertain that suitable grounding is available.**  
Statement 1024

---

 **Warning** **This unit might have more than one power supply connection. All connections must be removed to de-energize the unit.** Statement 1028

---

 **Warning** **Blank faceplates and cover panels serve three important functions: they prevent exposure to hazardous voltages and currents inside the chassis; they contain electromagnetic interference (EMI) that might disrupt other equipment; and they direct the flow of cooling air through the chassis. Do not operate the system unless all cards, faceplates, front covers, and rear covers are in place.** Statement 1029

---

 **Warning** **Only trained and qualified personnel should be allowed to install, replace, or service this equipment.** Statement 1030

---

 **Warning** **Ultimate disposal of this product should be handled according to all national laws and regulations.** Statement 1040

---

 **Warning** **Before opening the unit, disconnect the telephone-network cables to avoid contact with telephone-network voltages.** Statement 1041

---

 **Warning** **This product requires short-circuit (overcurrent) protection, to be provided as part of the building installation. Install only in accordance with national and local wiring regulations.**  
Statement 1045

---

 **Warning** **To prevent the system from overheating, do not operate it in an area that exceeds the maximum recommended ambient temperature of:**  
**35° C**

---

 **Warning** **This equipment is intended to be grounded to comply with emission and immunity requirements. Ensure that the switch functional ground lug is connected to earth ground during normal use.**  
Statement 1064

---

 **Warning** **Installation of the equipment must comply with local and national electrical codes.** Statement 1074

---

# Safety Guidelines

To reduce the risk of bodily injury, electrical shock, fire, and damage to the equipment, observe the precautions in this section.

## General Precautions

Observe the following general precautions for using and working with your system:

- Observe and follow service markings. Do not service any Identiv or Cisco product except as explained in your system documentation. Opening or removing covers that are marked with the triangular symbol with a lightning bolt may expose you to electrical shock. Components inside these compartments should be serviced only by an authorized service technician.
- If any of the following conditions occur, unplug the product from the electrical outlet and replace the part or contact your authorized service provider:
  - The power cable or plug is damaged.
  - An object has fallen into the product.
  - The product has been exposed to water.
  - The product has been dropped or damaged.
  - The product does not operate correctly when you follow the operating instructions.
- Keep your system components away from radiators and heat sources. Also, do not block cooling vents.
- Do not spill food or liquids on your system components, and never operate the product in a wet environment.
- Do not push any objects into the openings of your system components. Doing so can cause fire or electric shock by shorting out interior components.
- Use the product only with other Cisco- and Identiv-approved equipment.
- Allow the product to cool before removing covers or touching internal components.
- Use the correct external power source. Operate the product only from the type of power source indicated on the electrical ratings label. If you are not sure of the type of power source required, consult your service representative or local power company.
- Use only approved power cables. If you have not been provided with a power cable for your system or for any AC-powered option intended for your system, purchase a power cable that is approved for use in your country. The power cable must be rated for the product and for the voltage and current marked on the product's electrical ratings label. The voltage and current rating of the cable should be greater than the ratings marked on the product.
- To help prevent electric shock, plug the system components and peripheral power cables into properly grounded electrical outlets. These cables are equipped with three-prong plugs to help ensure proper grounding. Do not use adapter plugs or remove the grounding prong from a cable.
- Observe power strip ratings. Make sure that the total ampere rating of all products plugged into the power strip does not exceed 80 percent of the power strip ampere ratings limit.
- Do not use appliance or voltage converters or kits sold for appliances with your product.
- To help protect your system components from sudden transient increases and decreases in electrical power, use a surge suppressor, line conditioner, or uninterruptible power supply (UPS).

- Position cables and power cords carefully; route cables and the power cord and plug so that they cannot be stepped on or tripped over. Be sure that nothing rests on your system components' cables or power cord.
- Do not modify power cables or plugs. Consult a licensed electrician or your power company for site modifications. Always follow your local or national wiring rules.

## Protecting Against Electrostatic Discharge

Static electricity can harm delicate components inside the device. To prevent static damage, discharge static electricity from your body before you touch any of your system's electronic components. You can do so by touching an unpainted metal surface on the chassis.

You can also take the following steps to prevent damage from electrostatic discharge (ESD):

- When unpacking a static-sensitive component from its shipping carton, do not remove the component from the antistatic packing material until you are ready to install the component in your system. Just before unwrapping the antistatic packaging, be sure to discharge static electricity from your body.
- When transporting a sensitive component, first place it in an antistatic container or packaging.
- Handle all sensitive components in a static-safe area. If possible, use antistatic floor pads and workbench pads.

## Rack Installation Safety Guidelines

Before installing your device in a rack, review the following guidelines:

- Two or more people are required to install the device in a rack.
- Ensure that the room air temperature is below 95°F (35°C).
- Do not block any air vents; usually 6 inches (15 cm) of space provides proper airflow.
- Plan the device installation starting from the bottom of the rack.
- Install the heaviest device in the bottom of the rack.
- Do not extend more than one device out of the rack at the same time.
- Remove the rack doors and side panels to provide easier access during installation.
- Connect the device to a properly grounded outlet.
- Do not overload the power outlet when installing multiple devices in the rack.
- Do not place any object weighing more than 110 lb. (50 kg) on top of rack-mounted devices.





# Overview

---

This user guide describes how to install and configure the Identiv Connected Physical Access Manager (ICPAM) and the ICPAM appliance using the ICPAM desktop software. It also describes how to use the ICPAM desktop client to configure, manage, and monitor the ICPAM system.

This chapter provides an overview of the main hardware and software components of the ICPAM appliance, and a brief summary of the chapters and appendixes included in this ICPAM User Guide.



**Note**

---

Throughout this guide, the generic terms ‘controller’ or ‘controller or gateway’ are generally used to describe both the Identiv EM-100 controller and the Cisco Gateway. In those places where something applies only to the Cisco Gateway, the term ‘Cisco Gateway’ or ‘gateway’ is used. Similarly, in those places where something applies only to the EM-100 controller, the term ‘EM-100 controller’ is used.

---

## Contents

- [Overview: ICPAM Physical Device Connections, page 1-2](#)
- [Installation and Configuration Summary, page 1-3](#)
- [ICPAM Installation and Configuration Flowchart, page 1-10](#)
- [User Guide Contents, page 1-13](#)
- [ICPAM Software Overview, page 1-14](#)

# Overview: ICPAM Physical Device Connections

The ICPAM appliance is a hardware and software solution that provides advanced configuration and management of the ICPAM system, as shown in [Figure 1-1](#).

**Figure 1-1** *Identiv Connected Physical Access Manager System*

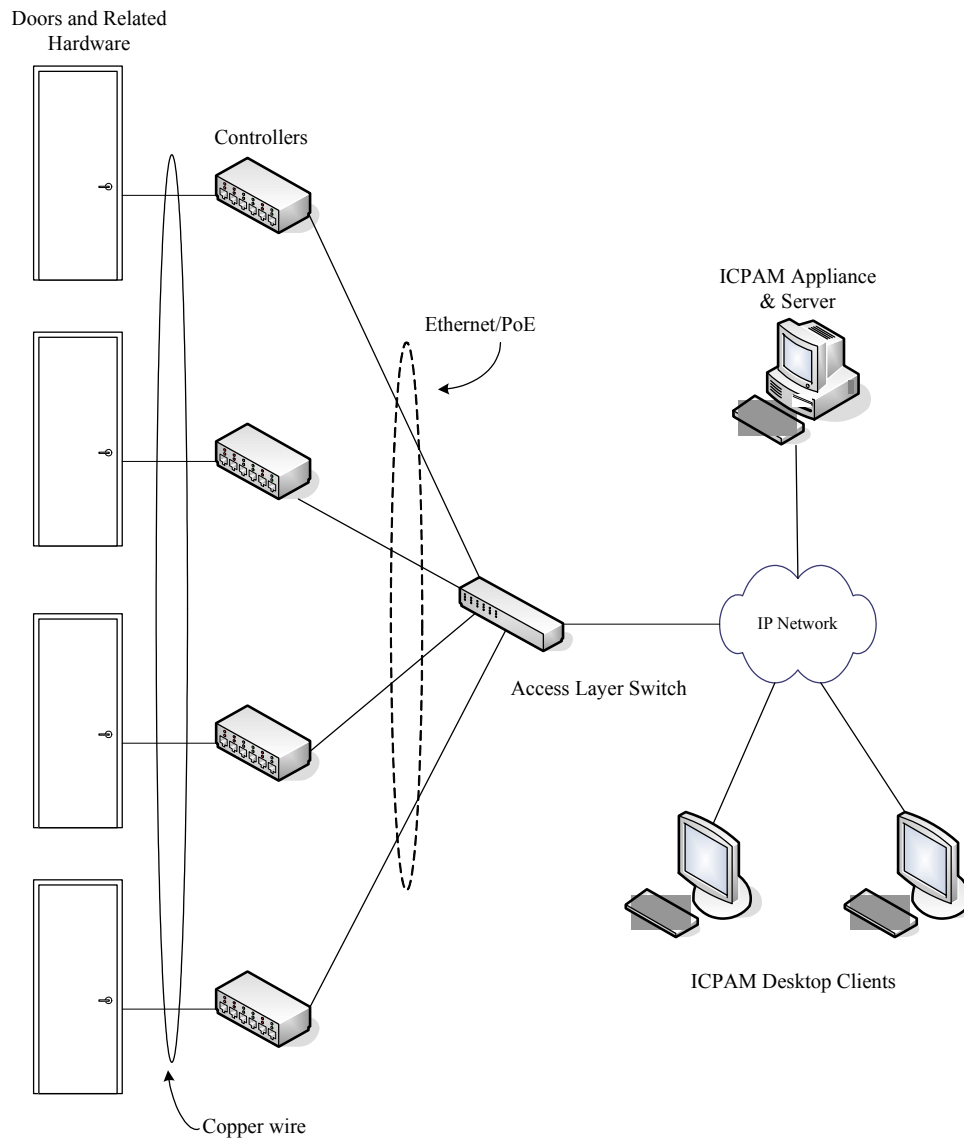

The ICPAM desktop client is used to define access control rules enroll users, manage badges, and configure the controllers, among other tasks.

- See [User Guide Contents, page 1-13](#) for descriptions of the topics covered in each chapter of this guide.
- See [Installation and Configuration Summary, page 1-3](#) for a description of the primary access control configuration tasks.
- See the *ICPAM Installation Guide* for instructions on how to install and configure controllers and door-related hardware.

# Installation and Configuration Summary

Perform the following high-level tasks to install and configure your ICPAM system.

- [Install the Cisco Gateway Hardware and Software Components](#)
- [Install the EM-100 Controller Hardware and Software Components](#)
- [Configure Doors and Users in ICPAM](#)

## Install the Cisco Gateway Hardware and Software Components

- Step 1** Install the appliance hardware. See the *Cisco Physical Security Multi Services Platform User Guide* or the *Cisco Physical Access 1125 Appliance User Guide* for more information.
- Step 2** Install and configure the server software. See [Chapter 2, “Configuring and Monitoring the ICPAM Server”](#).
- Step 3** Install the desktop client. See [Chapter 3, “Getting Started With the ICPAM Desktop Software”](#).
- Step 4** Install the door devices, including locks, readers, and other input and output devices.
- Step 5** Install the gateway modules and optional expansion modules, as described in the *Cisco Physical Access Gateway User Guide* and the *Cisco Physical Access Gateway Quick Start Guide*.



**Tip**

To ensure proper operation, test all door devices and modules on a lab bench before actual installation.

- Step 6** Connect an Ethernet cable from a PC to the ETH1 interface on the gateway module, then specify the gateway module’s network settings. See “Configuring and Managing the Gateway Using a Direct Connection” in the *Cisco Physical Access Gateway User Guide*. Also see the *Cisco Physical Access Gateway Quick Start Guide*.

**Figure 1-2** Cisco Access Control Gateway configuration utility, Network Setup page

The screenshot displays the 'Network Setup' page of the Cisco Access Control Gateway configuration utility. The page is divided into several sections:

- Eth0 Configuration:** Includes a checked checkbox for 'DHCP', and input fields for 'IP Address', 'Subnet Mask', and 'Default Gateway'.
- DNS Configuration:** Includes an input field for 'DNS Server'.
- Cisco PAM Configuration:** Includes input fields for 'Address' and 'Port' (set to 8020), and a checked checkbox for 'Enable SSL'.

At the bottom of the configuration area, there are buttons for 'Save' and 'Cancel'. Below these, a row of system management buttons includes 'Reset Application', 'Reboot', 'Reset Factory Defaults', 'Delete Events', 'Delete Configuration', and 'Delete Credentials'. The footer of the page contains the copyright notice: '© 2008-2012 Cisco Systems, Inc. All Rights Reserved.' and the ID '344917' on the right side.

- Step 7** Connect an Ethernet cable from the gateway ETH0 interface to the network.

**Tip**

You can also add the gateways to the network after configuring doors and users in ICPAM, as described in [Configure Doors and Users in ICPAM, page 1-5](#). For more information, see [Provisioned \(Pre-Populated\) vs. Discovered Controller Configurations, page 5-2](#).

- Step 8** Wait for the gateway to connect to the ICPAM appliance. Verify that the gateway status is *Up* in the Hardware Tree view (reached by selecting the **Doors > Hardware Tree** command in ICPAM).

## Install the EM-100 Controller Hardware and Software Components

- Step 1** Install and configure the server software. See [Chapter 2, “Configuring and Monitoring the ICPAM Server”](#).
- Step 2** Install the desktop client. See [Chapter 3, “Getting Started With the ICPAM Desktop Software”](#).
- Step 3** Install the door devices, including locks, readers, and other input and output devices.
- Step 4** Install the EM-100 controller modules as described in the *ICPAM Installation Guide*.

**Note**

To ensure proper operation, test all door devices and modules on a lab bench before actual installation.

- Step 5** Connect an Ethernet cable from a PC directly to the RJ-45 connector on the EM-100 controller.
- Step 6** Open a Web browser on the connected PC and enter this default URL: **https://169.254.242.121**.
- Step 7** On the resulting dialog:
- a. In the **User Name** field, type **admin**.

- b. In the **Password** field, type **identiv123**.
  - c. Click the **Log In** button.
- Step 8** Follow the instructions on the resulting Web page to configure the EM-100 controller. Most importantly, specify a fixed address for this controller so that ICPAM can locate and configure this controller for use within the system. For more information, see the *ICPAM Installation Guide*.

- Step 9** After this initial configuration is completed, disconnect the Ethernet cable between the configuring computer and the EM-100 controller, then connect the network cable (routed through the EM-100 controller's faceplate) to the EM-100 controller's RJ-45 socket.
- Step 10** Wait for the controller to connect to the ICPAM appliance. Verify that the controller status is *Online* in the Hardware Tree view (reached by selecting the **Doors > Hardware Tree** command in ICPAM).

## Configure Doors and Users in ICPAM

Configure users, doors, badges, and access policies, as described in the following summary:

- Step 1** Assign the appropriate device templates to the reader templates.

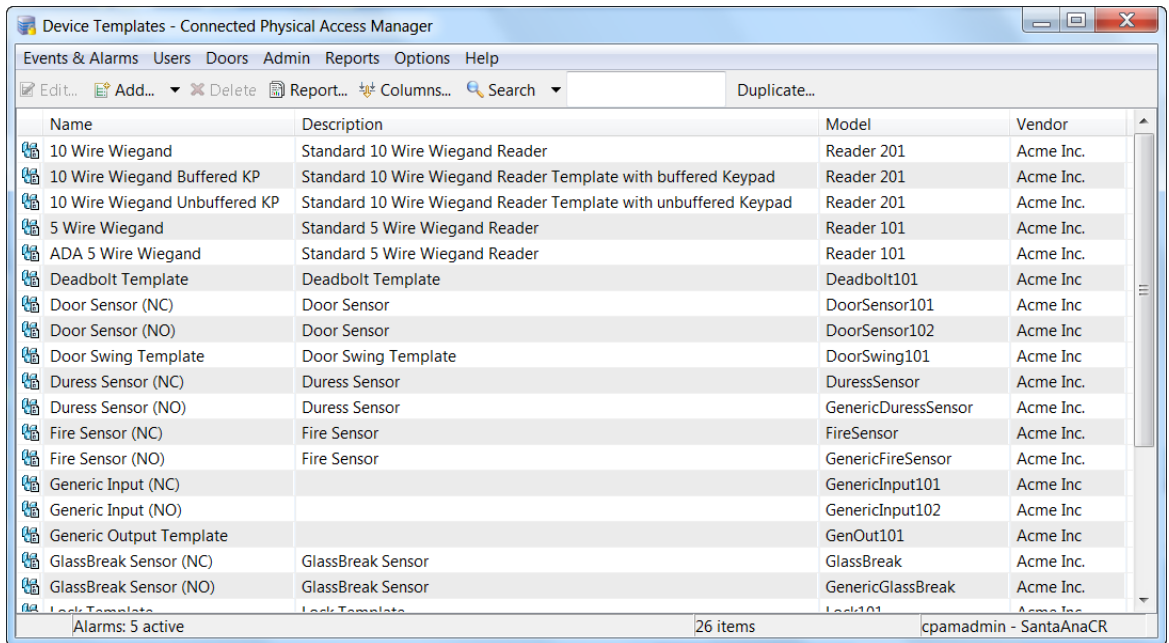

### Menu command:

**Doors > Templates > Device Templates**

### Instructions:

- [Understanding Device Templates, page 5-27](#)
- [Understanding Virtual Credential Templates, page 5-27](#)
- [Understanding Gateway Credential Templates, page 5-28](#)
- [Configuring Device Templates, page 8-11](#)
- To create additional credential templates, see [Configuring Credential Templates, page 8-15](#).

**Step 2** Configure controllers and doors:

- a. Use Gateway or EM-100 controller templates to add new controllers on the Hardware Tree.



---

**Note** Cisco Gateways and EM-100 controllers can be configured before connecting them to the network. You can also connect the modules to the network first, then complete the ICPAM configuration. See the [“Provisioned \(Pre-Populated\) vs. Discovered Controller Configurations” section on page 5-2](#) for more information.

---

- b. Create the hierarchical location map (select the **Doors > Door/Location-based Hardware** command in ICPAM).
- c. Add doors to the locations.
  - The Cisco Gateway controller is a two-door controller, which is no longer being sold but is still supported by ICPAM. In CPAM, you could add a door to a Gateway by right-clicking on the Physical Driver in the Hardware Tree and choosing the New Door... command from the pop-up menu. This changed in ICPAM, where you can add a door to a Gateway by right-clicking on the **Logical Driver** in the Hardware Tree and choosing the **New Door...** command from the pop-up menu. For more information, see [Adding Doors Using Door Templates, page 7-3](#).
  - Because the EM-100 controller is a single-door controller, to add another door you must add another controller, by right-clicking on the **Identiv EM-100 Driver** in the Hardware Tree and choosing the **New Identiv EM-100 Controller Wizard...** command from the pop-up menu. For more information, see [Configuring EM-100 Controllers Using Existing Templates, page 6-18](#).

**Menu commands:****Doors > Door/Location-based Hardware****Doors > Hardware Tree****Overview Information:**

- [Viewing Doors and Devices by Location, page 5-7](#)
- [Gateway Templates, page 5-26](#)

**Instructions:**

- [Creating the Location Map, page 5-8](#)
- [Configuring New Controllers, page 6-1](#)
- [Adding Doors Using Door Templates, page 7-3](#) or [Configuring EM-100 Controllers Using Existing Templates, page 6-18](#)



---

**Tip** To create additional controller and door templates, see [Chapter 8, “Configuring Door and Device Templates”](#).

---

**Step 3** Create access policies to define the days and times when users can access specific doors.

The screenshot shows the 'Add - Access Level' configuration window. The 'Name' field is set to 'New Access Level'. There are fields for 'Effective' and 'Expires' dates and times. The 'Enabled' checkbox is checked. The 'Location' dropdown is empty, with 'Choose...' and 'Clear' buttons. The 'Comments' field is empty. The 'Access Point Groups' tab is selected, showing a 'Schedule' dropdown set to 'Always Deny' and an 'Add...' button. Under 'Access points:', there is a search bar and a tree view showing 'TestingSite' with sub-items 'Door1' and 'Door2'. To the right, an 'Access point/schedule pairs:' section has a 'Clear' button and a table with columns 'Access Point', 'Schedule', and 'Status'.

**Menu command:**

**Doors > Access Policies**

**Configuration Instructions:**

- [Chapter 11, “Configuring Access Policies”](#)

- Step 4** Add personnel records and assign badges to grant user access to the doors. Then assign the appropriate access policies (created in the previous step) to the badges.

The image shows two overlapping software windows. The top window, titled "Add - Personnel Record", has a sidebar menu with options: General, Occupational, Contact, Badges, Keys, Parking Passes, Support Documents, Logins, Audit Records, and Recent Events. The main area is labeled "General" and contains fields for Title (set to "Dr."), First name, Middle name, Nickname, Last name, Suffix, and Date of birth. There are also buttons for Import, Export, Capture, and Clear.

The bottom window, titled "Add - Badge", has a sidebar menu with options: General, Badge Printing, Access Levels, Access Level Groups, Advanced, Advanced Gateway, Advanced EM-100, HSPD-12, Audit Records, and Recent Events. The main area is labeled "General" and contains fields for Card #, PIN, Hot stamp, Facility code, Issue code, Badge type (set to "Standard"), Linked temp. card #, Assigned to, Validity (set to "Active"), Watch level, Effective and Expires dates and times, and a Comments field. There are buttons for Read, Generate, Encode, View, and Select.

**Menu command:**

- **Users > Personnel**

**Configuration Instructions:**

- [Chapter 9, “Configuring Personnel and Badges”](#)

- Step 5** Add the controller modules to the network:
- Connect an Ethernet cable from a PC to the ETH1 interface on the gateway or the Ethernet interface on the EM-100 controller.
  - Specify the controller’s network settings.
  - Connect an Ethernet cable from the ETH0 interface on the Cisco gateway or the Ethernet connector on the Identiv EM-100 controller to the network.



- d. Wait for the gateway or EM-100 controller to connect to the ICPAM appliance. Verify that the controller status is *Up* or *Online* in the Hardware Tree view (reached by selecting the **Doors > Hardware Tree** command in ICPAM).



**Tip** Controllers are added to the ICPAM configuration in Step 2. You can also add the controllers to the network before configuring doors and users in ICPAM. See [Provisioned \(Pre-Populated\) vs. Discovered Controller Configurations, page 5-2](#) for more information.

**Instructions:**

- *ICPAM Installation Guide*

- Step 6** Right-click on a controller's entry in the Hardware Tree and select the **Apply Configuration Changes** command from the pop-up menu to apply the pending configuration changes to the selected controller. Repeat for each new controller you added in the previous step.

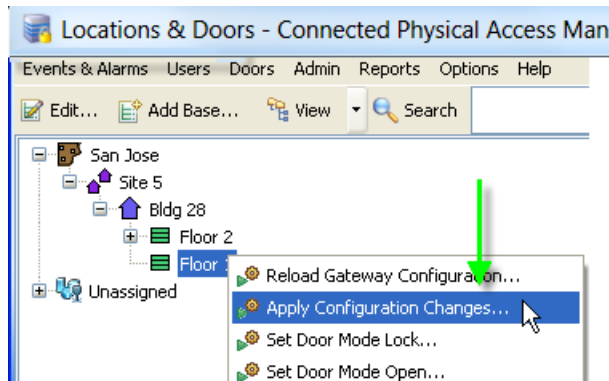

Note that you can also select this command from the right-click menu of the driver for either the gateway controllers or the EM-100 controllers, to apply the pending configuration changes for all the controllers of the selected type.

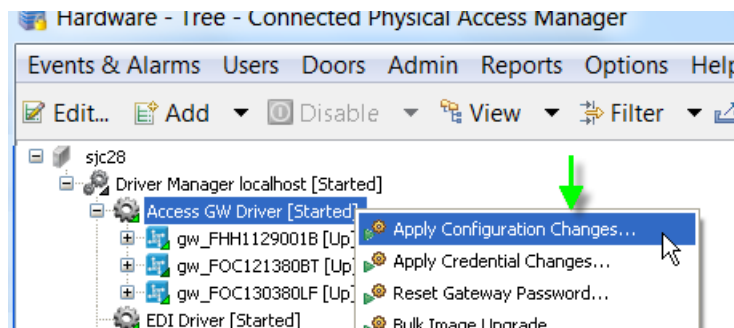

**Menu commands:**

- **Doors > Door/Location-based Hardware**
- **Doors > Hardware - Tree**

**Configuration Instructions:**

- [Applying Configuration Changes, page 7-14](#)

- Step 7** (Optional) If this is a gateway controller, you can clone the new gateway and door configuration, and then apply it to another gateway controller. This quickly adds an additional door to the ICPAM configuration. Specify the serial number and door name for the new gateway module. Repeat this process as many times as necessary.

	Gateway	Clone Gateway
Gateway name:	Gateway 2	
Gateway serial number:	F0C151280C8	
Gateway location:	Identiv, Inc.	
Module serial number:	F0C151280C8	
Door name:	Gateway Door 2	
Door location:	Identiv, Inc.	
<input type="checkbox"/> Clone all module names		
		OK Cancel

**Menu command:**

**Doors > Hardware Tree**

**Configuration Instructions:**

- [Creating Custom Gateway Configurations without Templates, page 6-2](#)
- [Cloning a Gateway Configuration, page 6-53](#)



**Tip** You can also create a gateway template from the configuration.

NOTE: If this is an EM-100 controller, you can save an existing controller as a ‘wizard template’ by expanding the Identiv EM-100 Driver in the Hardware Tree so the desired controller is visible, then right-clicking on it and choosing the **Save as Wizard Template...** command from the pop-up menu. For details, see [Creating Custom EM-100 Controller Configurations without Templates, page 6-15](#).

## ICPAM Installation and Configuration Flowchart

[Figure 1-3 on page 1-11](#) provides a guide to the installation and configuration of each procedure and feature required to run ICPAM, presented in the order in which they should be performed.



**Tip** The starting page number of the section in this guide where each process is detailed appears below the step.

Figure 1-3 ICPAM Installation and Configuration Flowchart

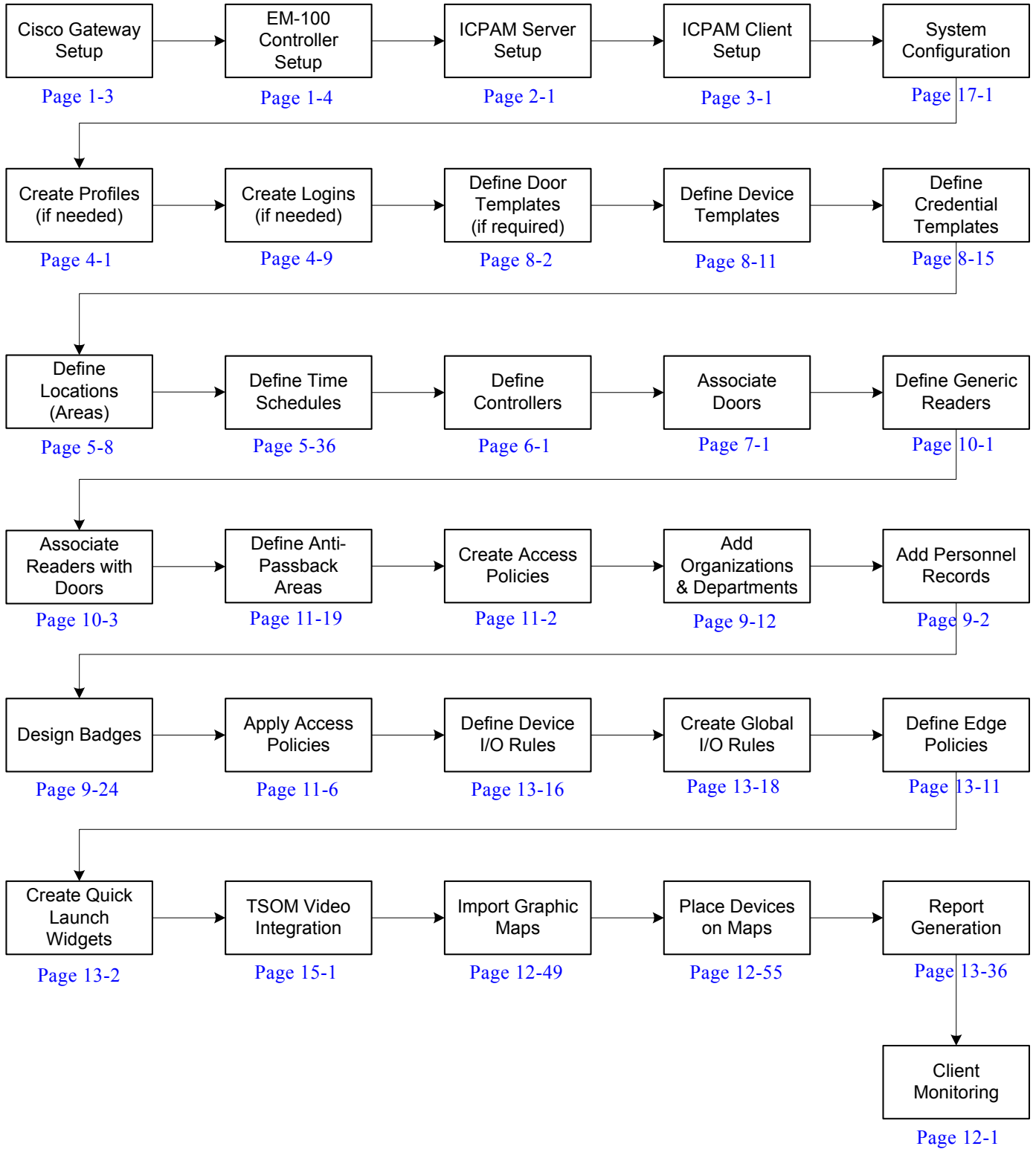

# System Recovery

In case of a system crash, the Recovery ISO image can be used to bring back the system to normal state.

The ISO image prompts you to select one of the following options:

- **Factory**
- **Recovery**

If you select the **Factory** option, the existing system is uninstalled completely and a new image is installed without any licenses. You can retrieve the original licenses by restoring the ICPAM database.

If you select the **Recovery** option, the following happens:

- The ICPAM database and the ICPAM software are retained.
- A fresh operating system is installed and the existing password is replaced by **cpamadmin**. This is provided as the password for the webadmin utility, the ICPAM client, and the SSH. (You are allowed to change the password later.)
- The ETH0 IP address is retained, but the rest of the network configuration must be manually configured again. After this reconfiguring, the network and the immortal services must be restarted.
- The DNS server requires reconfiguration using the webadmin utility.
- For a High Availability system with dual servers, the server which is recovered is the standby server.
- RPM is not uninstalled in the recovered server. So for a fresh ICPAM image to be installed, you must select the **Factory** option (when prompted by the Recovery ISO image).

# User Guide Contents

This User Guide describes how to install and configure the ICPAM appliance, and how to use the ICPAM desktop client to configure, manage, and monitor the Identiv Connected Physical Access Manager system.

Table 1-1 describes the chapters and subjects included in this guide.

**Table 1-1** *Chapters and Appendixes in the ICPAM User Guide*

Chapter or Appendix	Description
Chapter 1, "Overview"	Introduces the main ICPAM hardware and software components.
Chapter 2, "Configuring and Monitoring the ICPAM Server"	Describes how to configure the ICPAM server software, including optional feature licenses and high availability. This chapter also describes the additional server monitoring and configuration features of the ICPAM Server Administration utility.
Chapter 3, "Getting Started With the ICPAM Desktop Software"	Describes how to install the ICPAM desktop client software, log on to ICPAM, and begin configuring access control features and doors. This chapter also includes an overview of the ICPAM user interface.
Chapter 4, "Configuring User Access for the ICPAM Desktop Client"	Describes how to configure ICPAM operators.
Chapter 5, "Understanding Controller and Door Configurations"	Describes the terms and concepts used to configure doors and templates.
Chapter 6, "Configuring Controllers"	Describes how to configure the controllers and gateways for use with the ICPAM system.
Chapter 7, "Configuring Doors"	Describes how to configure doors, including how to clone controller or gateway configurations to quickly create another door.
Chapter 8, "Configuring Door and Device Templates"	Describes how to create and modify ICPAM door and device templates.
Chapter 9, "Configuring Personnel and Badges"	Describes how to create the personnel records and badges used to access doors in the Identiv Connected Physical Access Manager system.
Chapter 10, "Multifactor Authentication"	Describes how to configure additional access control devices to ensure security. These devices are called as generic readers. These generic readers are biometric devices.
Chapter 11, "Configuring ICPAM Access Policies"	Describes how to create the access policies assigned to badge holders that define which doors they can access, and the dates and times of that access. After they have been created, access policies are assigned to personnel badges.
Chapter 12, "Events & Alarms"	Describes how to view the event and alarm records in ICPAM, and how to use the Event Policy Manager to configure the log codes and other properties that define how events are captured and managed.
Chapter 13, "Configuring Automated Tasks"	Describes how to used to create and manage automated tasks to perform actions such as Trigger a relay when an alarm is generated, play alarm video, or generate a report and e-mail it to a user.

Table 1-1 Chapters and Appendixes in the ICPAM User Guide (continued)

Chapter or Appendix	Description
<a href="#">Chapter 14, “System Integration”</a>	Describes how to use EDI to automatically synchronize ICPAM records with the databases from other sources, such as an organization’s HR personnel records. Also describes how to use URL actions to automatically synchronize data with other sources.
<a href="#">Chapter 15, “Video Monitoring”</a>	Describes how to view live and recorded video streams from the Cisco Video Surveillance Manager (Cisco VSM), including how to view video clips associated with events and alarms.
<a href="#">Chapter 16, “VoIP Integration”</a>	Describes how to configure a VoIP phone to ICPAM as an additional feature to provide access to personnel without badges.
<a href="#">Chapter 17, “System Configuration Settings”</a>	Describes the system-wide site settings available in the System Configuration module.
<a href="#">Appendix A, “Backing Up and Restoring Data”</a>	Describes how to backup and restore the ICPAM database.
<a href="#">Appendix B, “Upgrading the Server Software”</a>	Describes how to upgrade or reinstall the ICPAM server software, desktop client software, and controller module firmware.
<a href="#">Appendix C, “Upgrading and Configuring Gateways”</a>	Describes how to configure network addresses, including IP addresses and an NTP server on the controller or gateway module using the ICPAM software. Also describes how to upgrade the module firmware.
<a href="#">Appendix D, “Security”</a>	Provides security information related to the configuration and operation of the ICPAM software.
<a href="#">Appendix E, “Troubleshooting”</a>	Describes troubleshooting techniques for the ICPAM software.
<a href="#">Appendix F, “Related Documentation”</a>	Provides links to related ICPAM documentation, and documentation for related products.
<a href="#">Glossary</a>	Provides definitions to terms used in the ICPAM system.
<a href="#">Index</a>	Provides an index to subjects within the manual.

## ICPAM Software Overview

Although the ICPAM desktop client is the main tool used to configure and manage the Identiv Connected Physical Access Manager system, a number of additional utilities perform specific tasks, such as configuring the appliance or designing data integration projects.

- [ICPAM Desktop Client Software, page 1-15](#)
- [ICPAM Server Administration Utility, page 1-16](#)
- [Controller or Gateway Administration Utility, page 1-16](#)
- [The Enterprise Data Integration \(EDI\) Desktop Studio, page 1-18](#)
- [Cisco Video Surveillance, page 1-18](#)
- [Badge Designer, page 1-19](#)

## ICPAM Desktop Client Software

The ICPAM Manager (Figure 1-4) is a Java-based desktop client used to configure the ICPAM appliance and access control features.

See Chapter 3, “Getting Started With the ICPAM Desktop Software” for instructions to install the application and log in to the system. That chapter also includes an introduction to the ICPAM appliance user interface, a summary of access control configuration tasks, and an overview of the user interface.

**Figure 1-4** ICPAM Context Diagram

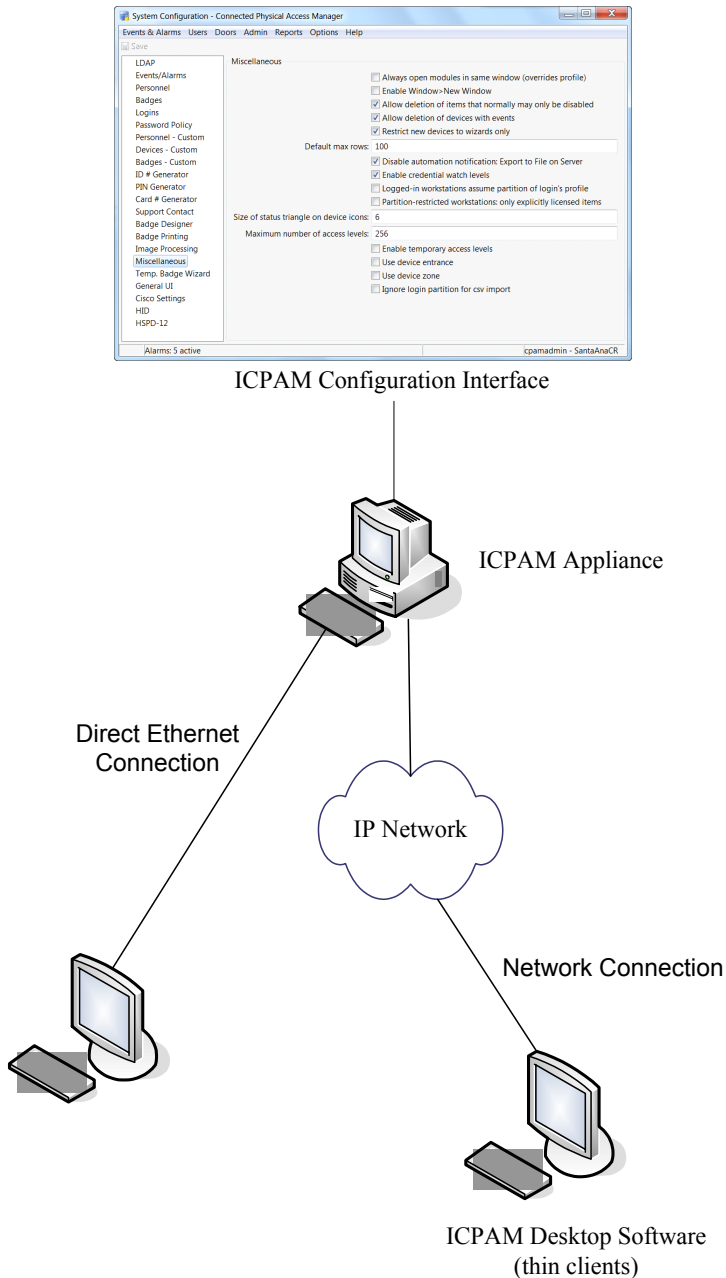

## ICPAM Server Administration Utility

The ICPAM Server Administration utility (Figure 1-5) is a Web-based tool used to configure and monitor the ICPAM appliance server software. Use this utility to set up a new server, install the desktop client software, back up data, install licenses, and perform a variety of other server maintenance and monitoring tasks.

See Chapter 2, “Configuring and Monitoring the ICPAM Server” for more information.

Figure 1-5 ICPAM Server Administration Utility, Initial Setup

The screenshot displays the 'Initial Setup' page of the ICPAM Server Administration Utility. The page header includes the Identiv logo and the text 'Connected PAM Server Administration'. On the right side of the header, there are links for 'Welcome', 'Log Out', 'About', and 'Help'. A sidebar on the left lists 'Setup Steps' from 1 to 7: 1 - Server, 2 - User, 3 - Network, 4 - DNS, 5 - Email, 6 - Date & Time, and 7 - Event. The main content area is titled 'Initial Setup' and contains the following form fields:

- Username:
- Current Password\*:
- New Password\*:
- Re-enter Password\*:
- Email Address:

At the bottom of the form, there are three buttons: '< Back', 'Next >', and 'Cancel'. The footer of the page reads 'Copyright © 2015 Identiv, Inc. | All Rights Reserved.'

## Controller or Gateway Administration Utility

The Cisco Gateway Administration utility (Figure 1-6) uses a direct PC connection to specify the initial network settings on a gateway module. You can also use the utility to upgrade firmware, and perform other monitoring and maintenance tasks.

See the *Cisco Physical Access Gateway User Guide* for instructions on how to use this tool.



Figure 1-6 Cisco Access Control Gateway Administration Utility

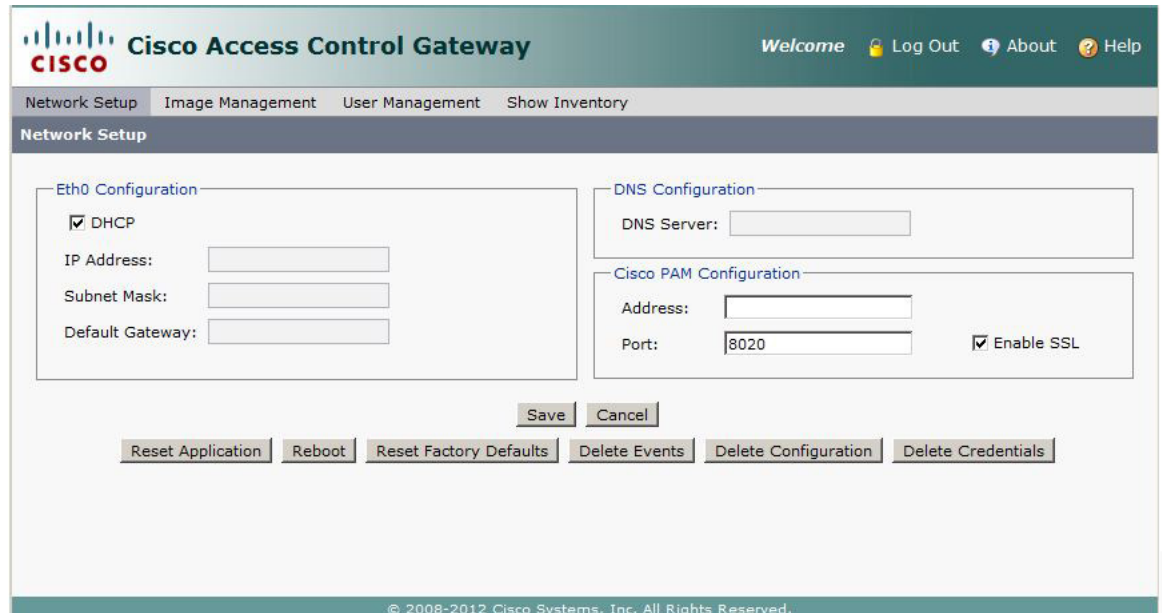

The Identiv EM-100 controller's setup utility (Figure 1-7) uses a direct PC connection to specify the initial network settings for the controller. You can also use the utility to upgrade the controller's firmware and perform other monitoring and maintenance tasks.

See the *ICPAM Installation Guide* for instructions on how to use this tool.

Figure 1-7 EM-100 Controller Setup Utility

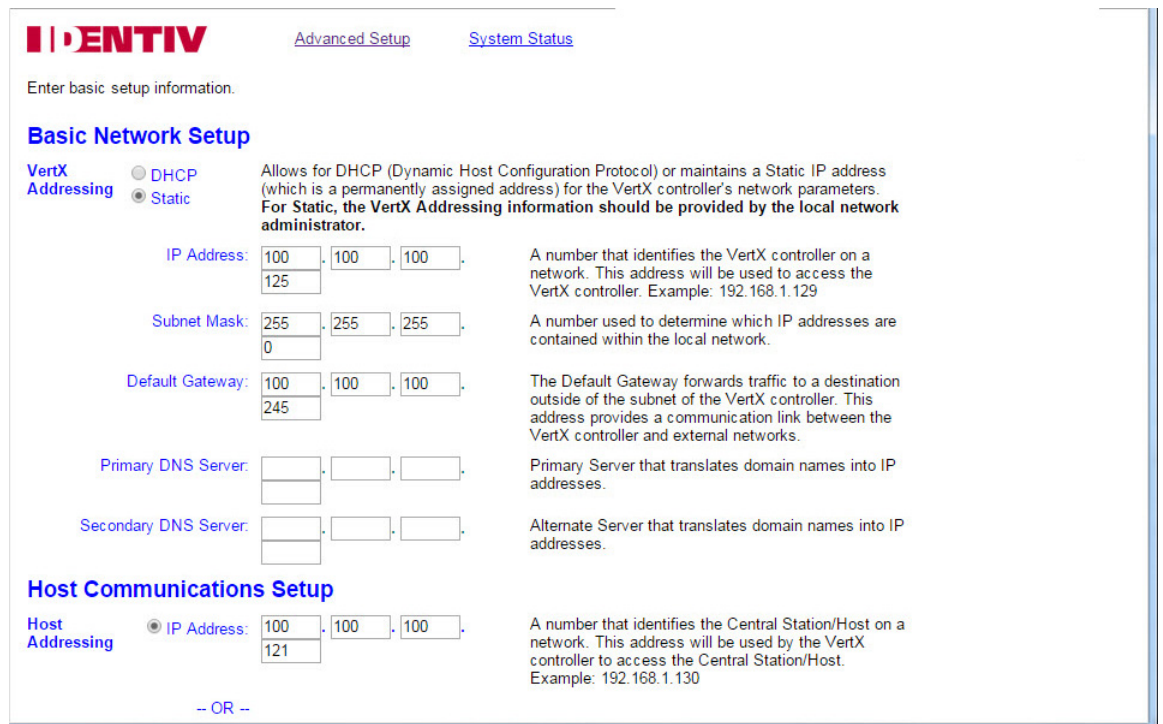

## The Enterprise Data Integration (EDI) Desktop Studio

The EDI Studio (Figure 1-8) is a desktop application used to create data integration projects for automatically synchronizing ICPAM with other databases, such as an HR personnel database. The EDI Studio defines the database connection, schema, and synchronization schedule used by the EDI module in ICPAM.

See [Chapter 14, “System Integration”](#) for more information.

**Figure 1-8** *EDI Studio Desktop Software*

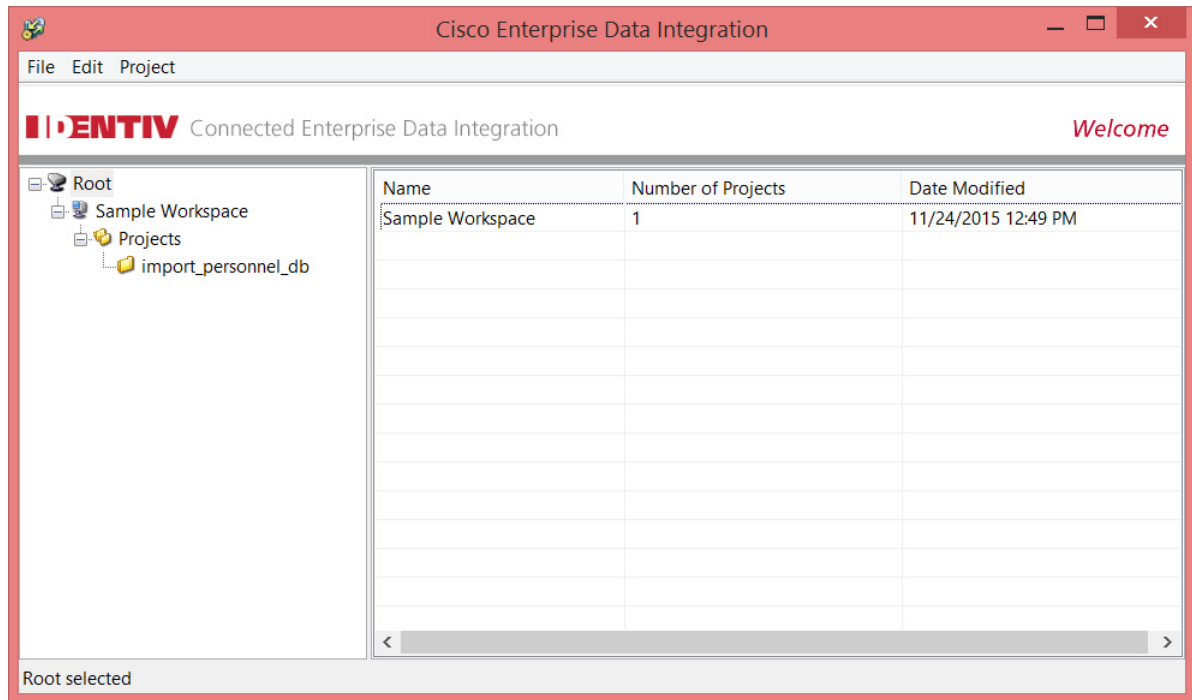

**Note**

This optional feature requires a separate license. The **EDI** menu appears only after the license is installed on the ICPAM server. See the [“Obtaining and Installing Optional Feature Licenses”](#) section on page 2-45 for more information.

## Cisco Video Surveillance

The Cisco VSM Video Player is a desktop application used to archived video from the Video Surveillance Manager. See [Chapter 15, “Video Monitoring”](#) for more information.

# Badge Designer

The Badge Format (Figure 1-9) feature is included with the optional Badge Designer module to create and modify badge designs. See Chapter 9, “Configuring Personnel and Badges” for more information about designing and modifying badges.

Figure 1-9 Badge Designer

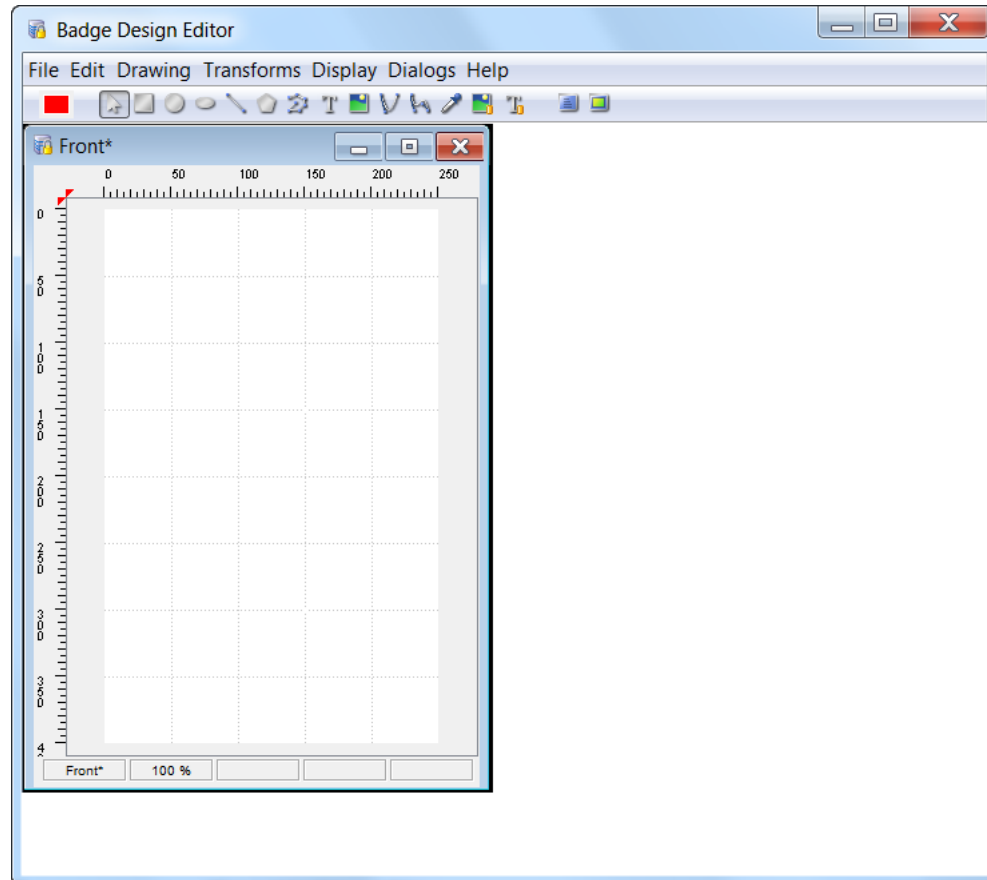



# Configuring and Monitoring the ICPAM Server

---

This chapter describes how to configure the ICPAM server software, including optional feature licenses and high availability. This chapter also describes the additional server monitoring and configuration features of the ICPAM Server Administration utility.

When you log on to the appliance for the first time, a set of initial setup screens appear. Enter the settings and other information as described in this chapter.

After the initial setup is complete, the main administration utility windows are displayed, enabling you to install the ICPAM desktop client software and additional feature licenses. A variety of other configuration and monitoring tasks can also be performed.

## Contents

- [Overview, page 2-2](#)
  - [About the ICPAM Server Administration Utility, page 2-2](#)
  - [Logging on to the ICPAM Server Administration Utility, page 2-2](#)
  - [Using Redundant Appliances for High Availability, page 2-2](#)
  - [Understanding IP Addresses on the ICPAM Server, page 2-3](#)
- [Entering the Initial Server Configuration, page 2-5](#)
- [Configuring ICPAM on a Virtual Machine \(VM\), page 2-17](#)
- [Using the Web Admin Menus, Commands, and Options, page 2-19](#)
  - [Menus and Options in the ICPAM Server Administration Utility, page 2-20](#)
  - [Archiving Historical Events, page 2-25](#)
  - [Installing and Revising Language Packs, page 2-30](#)
  - [Changing or Recovering the Server Password, page 2-40](#)
  - [Obtaining and Installing Optional Feature Licenses, page 2-45](#)
  - [Displaying the ICPAM Appliance Serial Number, page 2-48](#)
  - [Performing a Graceful Failover with Redundant Appliances, page 2-49](#)
- [Troubleshooting and Monitoring, page 2-49](#)
- [Next Steps, page 2-49](#)

# Overview

This chapter provides background information to use the ICPAM Server Administration utility to perform the initial setup of your ICPAM appliance.

Refer to the following topics:

- [About the ICPAM Server Administration Utility, page 2-2](#)
- [Logging on to the ICPAM Server Administration Utility, page 2-2](#)
- [Using Redundant Appliances for High Availability, page 2-2](#)
- [Understanding IP Addresses on the ICPAM Server, page 2-3](#)

## About the ICPAM Server Administration Utility

The ICPAM Server Administration utility is a Web-based tool used to enter server settings for the ICPAM appliance, including network addresses, feature licenses, and high availability settings. The utility also performs a variety of maintenance and monitoring tasks, including backup and restore, system logs, and resetting the server.

- When you access the utility for the first time, the initial setup screens appear. See [Entering the Initial Server Configuration, page 2-5](#).
- After the initial server configuration is complete, see [Using the Web Admin Menus, Commands, and Options, page 2-19](#).

**Note**

The ICPAM server software is different from the desktop client software. The desktop (client) software runs on a PC and is used to configure devices and access control settings. Whenever you upgrade the server software, you must also upgrade the desktop software. If the versions are not the same, an error occurs when launching the desktop client. See [Installing or Updating the ICPAM Desktop Software, page 3-2](#).

## Logging on to the ICPAM Server Administration Utility

To log on to the ICPAM Server Administration utility, use one of the following methods:

- Connect a PC directly to the server Eth0 port, as described in [Entering the Initial Server Configuration, page 2-5](#).
- Log in to the ICPAM Server Administration utility over the Internet using the Eth0 port IP address. You can also use the Shared IP address when two servers are set up in a redundant HA configuration. Ask your system administrator for the correct IP address.
- The Eth1 port can optionally be enabled for ICPAM Server Administration utility connections over the web. The Eth1 port is disabled by default.

## Using Redundant Appliances for High Availability

High availability is achieved by installing two ICPAM appliances in a redundant configuration. One appliance acts as the active server, and the second appliance runs in warm standby mode. All data and configurations on the active appliance are automatically mirrored on the standby appliance to minimize

any data loss or system downtime if a failover occurs. If the active appliance goes off-line, the standby appliance automatically assumes full control of the system, including the Shared IP address and optional feature licences.

**Note**

The high availability (HA) feature requires a separate license. See [Obtaining and Installing Optional Feature Licenses, page 2-45](#).

## Understanding IP Addresses on the ICPAM Server

The ICPAM appliance IP address provides network communication between the appliance and the controller modules. The IP address is also used to log in to the system using either a Web browser or the ICPAM desktop client.

This section describes the different IP addresses that can be configured on an appliance: Eth0, Eth1, and the Shared IP Address.

- [ICPAM Appliance IP Addresses, page 2-3](#)
  - [Eth0 Port IP Address, page 2-3](#)
  - [Shared IP Address, page 2-3](#)
  - [Eth1 Port IP address, page 2-4](#)
- [Upgrading a Single Standalone Server to an HA Configuration, page 2-4](#)
- [Controller and Gateway Module IP Addresses, page 2-4](#)

**Note**

Contact your system administrator for the specific IP address settings used in your system.

## ICPAM Appliance IP Addresses

Each appliance must be configured with an *Eth0* IP address. Servers in a redundant configuration must also be configured with a *Shared* IP address. The *Eth1* port is disabled by default but can also be enabled and assigned an IP address. Review the following summaries to determine the configuration required by your deployment.

### Eth0 Port IP Address

- In a standalone configuration, the *Eth0* IP address provides communication between the ICPAM appliance and the controller or controllers. The *Eth0* IP address is also used to log on to the ICPAM Server Administration utility.
- In a redundant HA configuration, the *Eth0* ports provides communication between the active and standby appliances. The *Eth0* IP address for the active and standby appliance must be different.

### Shared IP Address

- The *Shared IP address* is used in a redundant HA configuration and is transferred from the active to the standby server if a failover occurs. This allows system communication to continue since controller or controllers and end users will continue to communicate with the same IP address even after a failover to a different physical server.

- In an HA configuration, the *Shared IP address* is used to log on to the ICPAM Server Administration utility, and is configured on each controller.
- The *Shared IP address* and the *Eth0* IP address should be on the same subnet.

### Eth1 Port IP address

- The *Eth1* port is disabled by default. You can enable and configure the *Eth1* port for remote Internet connections to the ICPAM Server Administration utility.
- *Eth0* and *Eth1* can be on separate subnets.

## Upgrading a Single Standalone Server to an HA Configuration

To change a single standalone server to the active server in an HA configuration, you must configure a Shared IP address on the existing standalone server, and then configure a standby server with the same Shared IP address.

The new Shared IP address is used to log in to the system, and is used for network communication by the controllers.



### Note

---

The active and standby servers must have unique Eth0 IP addresses.

---

See the [Appendix B, “Upgrading the Server Software”](#) for more information.

If possible, we recommend assigning two IP addresses to a single standalone ICPAM server: *Eth0* and the *Shared IP Address*. This enables you to switch from a standalone configuration to an HA configuration without changing the IP address required for user logins.

## Controller and Gateway Module IP Addresses

The Identiv EM-100 controller and the Cisco Gateway module are configured with the following field values:

- **ICPAM Configuration**—defines the IP address and port of the ICPAM appliance used to manage the controller. This can be either the Eth0 address in a standalone configuration, or the Shared IP address in an HA configuration. See the [“ICPAM Appliance IP Addresses”](#) section on page 2-3.
- **Eth0**—defines the network settings for the Eth0 port on the Cisco Gateway. Eth0 is used for network connectivity with the ICPAM appliance.
- **IP Address**—defines the network setting for the Ethernet port on the Identiv EM-100 controller. This address is used for communication between the ICPAM appliance and the network.
- **ICPAM Configuration Address**—defines the IP address for the ICPAM appliance to which the Identiv EM-100 controller is connected. There is also a port address that must be designated for the EM-100 controller.
- **DNS**—defines the domain name server (DNS) if names, not IP addresses, are used for the NTP or ICPAM addresses.

For instructions about how to install and configure Cisco Gateway modules, see the [Cisco Physical Access Gateway User Guide](#). For instructions about installing and configuring the EM-100 controller, see the [ICPAM Installation Guide](#).

To use ICPAM to configure Gateway network settings, see the [“Changing the Gateway Network Settings”](#) section on page C-3.



# Entering the Initial Server Configuration

The initial setup screens appear automatically when you boot the ICPAM appliance for the first time, (or after a complete system restore). The instructions in this section are for a standalone server, or for the two servers in a redundant (high availability) configuration.

- [Before You Begin, page 2-5](#)
- [Connecting a PC to the Appliance, page 2-5](#)
- [Initial Setup Instructions, page 2-7](#)

## Before You Begin

Before you power on the ICPAM appliance, you need the following:

- A PC and Web browser (Internet Explorer 6.0 or higher).
- An Ethernet cable to connect your PC directly to the ICPAM appliance. Cross-over and straight-through cables are supported.

In addition, gather the following information:

- IP, subnet, and gateway addresses for the ICPAM appliance:
  - For a standalone server installation, one IP address for Eth0 is required.
  - For a redundant (HA) server configuration, two IP addresses are required: one address for the Shared IP Address setting, and a second address for the Eth0 port. See [Understanding IP Addresses on the ICPAM Server, page 2-3](#).
- (Optional) If using NTP synchronization, the address of the NTP server.
- (Optional) The DNS server settings.
- (Optional) If event archives will be backed up to a remote server, the FTP or SFTP server address, username, and password.
- Administrator password. If you are setting up the appliance for the first time, use the default password **cpamadmin**.

## Connecting a PC to the Appliance

To complete the initial ICPAM configuration, connect an Ethernet cable from a PC to the ICPAM appliance Eth0 port. Use a Web browser to enter the required settings.

- 
- Step 1** Connect an Ethernet cable from your PC to the Eth0 port on the ICPAM appliance (the Eth1 port is disabled by default). See *Cisco Physical Security Multi Services Platform User Guide* or *Cisco Physical Access 1125 Appliance User Guide* for the location of the appliance ports.



---

**Note** After configuration is complete, disconnect the Eth0 cable from the PC, and connect the appliance to the IP network.

---

- Step 2** Power on the appliance. See *Cisco Physical Security Multi Services Platform User Guide* or *Cisco Physical Access 1125 Appliance User Guide* for the location of the power button.

**Step 3** Open a Web browser on your PC and enter the URL: <https://192.168.1.2>.



**Note** Be sure to include the *s* in *https://*. This connects your browser to the secure URL.

**Step 4** Enter the default username and password as shown in [Figure 2-2](#):

default username: `cpamadmin`

default password: `cpamadmin`

**Figure 2-1** ICPAM Server Administration Utility: Login



**Tip** The default `cpamadmin` password is used the first time you log into the active or standby appliance. You are required to configure a new password during the initial setup process, as described in [Initial Setup Instructions, page 2-7](#). The `cpamadmin` username cannot be changed.



**Note** See [Changing or Recovering the Server Password, page 2-40](#) for more information.

## Initial Setup Instructions

To enter the initial configuration for a ICPAM appliance, do the following:

**Step 1** Log on to the appliance, as described in [Connecting a PC to the Appliance, page 2-5](#).

**Step 2** Enter the server configuration, as shown in [Figure 2-2](#):



**Note** The version and serial number are not configurable.

- a. **Type:** Select the server type to enable the configuration options for the appliance.
  - **Active Server:** (Default) Select **Active Server** for a single appliance, or if the appliance is the active server in a redundant configuration.
  - **Standby Server:** Select **Standby Server** if the appliance is the standby server in a redundant configuration. A standby server must have the exact same configuration settings as the active *except* the network addresses, host name, and HA license.

**Figure 2-2** ICPAM Server Initial Setup: Server Configuration

The screenshot shows the 'Initial Setup' page of the ICPAM Server Administration interface. The page has a dark header with the ENTIV logo and navigation links like 'Welcome', 'Log Out', 'About', and 'Help'. A sidebar on the left lists 'Setup Steps' from 1 to 8, with '1 - Server' selected. The main content area is titled 'Initial Setup' and contains the following fields:

- Version: 2.0.0(0.3.9)
- Serial Number: A46C2A65AD54
- Type: Active Server (dropdown menu)
- Site Name\*: (disabled text input field)

At the bottom of the form, there are three buttons: '< Back', 'Next >', and 'Cancel'.

- b. **Site Name:** Enter a description for the appliance to identify the appliance on the network. This field is disabled for a standby appliance because the standby server assumes the active server's name when a failover occurs.

Enter any combination of letters and numbers up to 32 characters. Spaces are not allowed, but dash and underscore characters are allowed.

For example: SJCSite1

- c. Click **Next** to apply the settings and continue.

- Step 3** Enter the initial User settings to define the administrator password and email address, as shown in [Figure 2-3](#). Enter the same settings on the active and standby appliance.

**Figure 2-3** ICPAM Server Initial Setup: User Configuration

- a. **Username:** The admin username cannot be changed. The default username is `cpamadmin`.
  - b. **Current Password:** Enter the administrator password. The default password is `cpamadmin`.
  - c. **New Password:** Enter a new administrator password. The administrator has full rights to configure the ICPAM appliance, and grant access rights to other users. The new password is required and must be entered to continue.
  - d. **Re-enter Password:** Re-enter the administrator password to confirm the setting.
  - e. **Email Address:** (Optional) Enter the email address that will receive system messages. This email address also receives Forgot Password emails (see [Resetting a Forgotten Password, page 2-41](#)).
  - f. Select **Next** to apply the settings and continue.
- Step 4** Specify the Network configuration for the ICPAM appliance, as shown in [Figure 2-4](#). Note that:
- The Shared IP address, Port, and SSL are the same on the active and standby appliances.
  - The host name must be different for the active and standby appliances.
  - The Eth0 and Eth1 IP addresses must be different on the active and standby appliances.
  - All IP addresses must be on the same subnet.

Figure 2-4 ICPAM Server Initial Setup: Network Configuration

Specify the following Network settings:

- a. **Host Name:** Enter the host name on the active appliance. Enter a different host name on the standby appliance. The host name is used to identify the appliance on the local network and does not impact other configurations.
- b. **Shared IP Address:** Enter the same IP address on the active and standby appliance. This address is transferred from the active to the standby appliance if a failover occurs. We recommend configuring a Shared IP Address on all appliances, even if the appliance is a standalone (non-HA) configuration. See [Understanding IP Addresses on the ICPAM Server, page 2-3](#) for more information.  
The Shared IP address and the Eth0 IP address should be on the same subnet. Eth0 and Eth1 can be on separate subnets.
- c. **Transport Port:** The default value is 8020. Enter the same number on the active and standby appliances.
- d. **SSL Enable For Server:** Click the **SSL** check box to enable or disable secure IP communication between the ICPAM appliance and attached controllers. The settings must be the same on the active and standby appliances.



**Note** SSL is enabled by default on all controllers and ICPAM appliances. If SSL is disabled for a controller but enabled for ICPAM, the controller will not be able to connect to the appliance. If the SSL settings are changed, reset all controllers and the ICPAM appliance. Identiv recommends enabling SSL to ensure secure communications.

- e. **Eth0:** (Required) Enter a static IP address for the Eth0 port. If the appliance is a standalone server, this port is the ICPAM appliance IP address. In a redundant (HA) configuration, the Eth0 port is used for HA communication between the active and standby appliance. The active appliance must have a different Eth0 IP address than the standby appliance.

See [Understanding IP Addresses on the ICPAM Server, page 2-3](#) for more information.

- **IP Address:** Enter the IP address for the Eth0 port. This address should be on the same subnet as the Shared IP address, and must be different on the active and standby appliances.
  - **Subnet Mask:** Enter the subnet mask provided by your system administrator.
  - **Gateway:** (Optional) Enter the gateway provided by your system administrator.
- f. **Eth1:** This port is disabled by default. You can enable and configure the Eth1 port for remote Internet connections to the ICPAM Server Administration utility.
- **Enable Interface:** Click the check box to enable or disable the Ethernet interface.
  - **DHCP:** Click the check box to enable or disable DHCP. When DHCP is enabled, the IP following address fields are inactive since the information is supplied by a DHCP server.
  - **IP Address:** Enter the IP address for the Eth0 port. If configured, this address must be different on the active and standby appliances.
  - **Subnet Mask:** Enter the subnet mask provided by your system administrator.
  - **Gateway:** (Optional) Enter the gateway provided by your system administrator. If a gateway is provided for Eth0, leave this field blank.
- g. Click **Next** to apply the settings and continue.

**Tip**



---

Either the Eth0, Eth1, or Shared IP address can be used to connect a PC to the ICPAM Server Administration utility over the Internet. Ask your system administrator for the IP address used for this purpose in your system.

---

- Step 5** (Optional) Enter the **DNS** Settings for the ICPAM appliance. Enter the same settings on the active and standby appliance.
- a. **Primary DNS:** (Optional) Enter the domain name server (DNS) for the ICPAM appliance.
  - b. **Secondary DNS:** (Optional) Enter the secondary DNS.
  - c. **Domain:** (Optional) Enter the domain name for the appliance.
  - d. Click **Next** to apply the settings and continue.
- Step 6** (Optional) Specify the SMTP email settings used to send messages from the ICPAM appliance. Specify the same settings on the active and standby appliance.

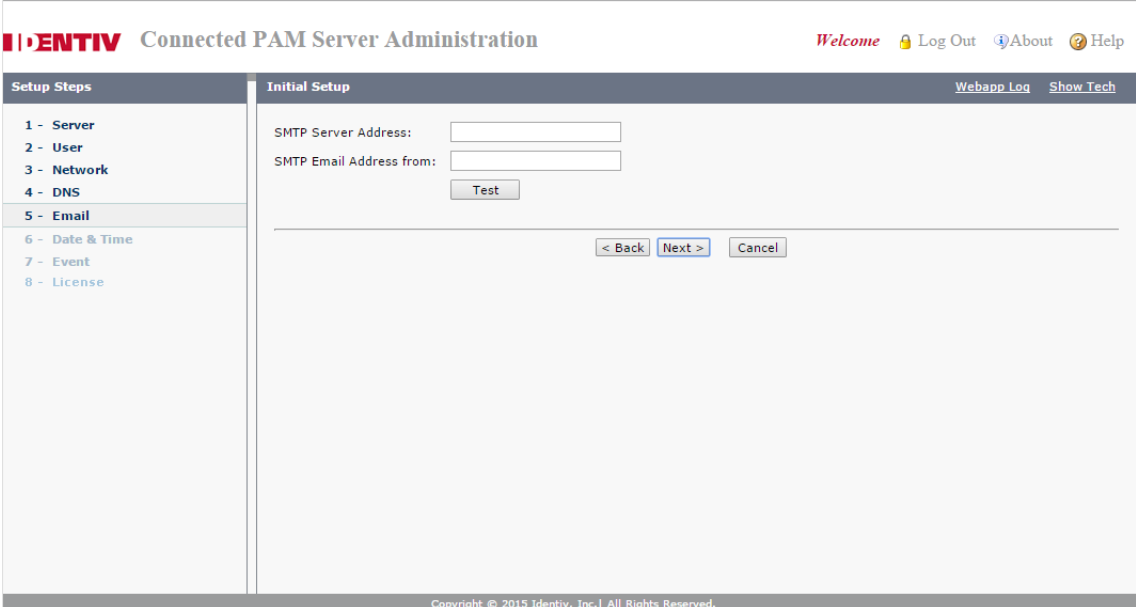
Figure 2-5 ICPAM Server Initial Setup: Email Configuration



IDENTIV Connected PAM Server Administration Welcome Log Out About Help

**Setup Steps** Webapp Log Show Tech

- 1 - Server
- 2 - User
- 3 - Network
- 4 - DNS
- 5 - Email
- 6 - Date & Time
- 7 - Event
- 8 - License

**Initial Setup**

SMTP Server Address:

SMTP Email Address from:

---

Copyright © 2015 Identiv, Inc. All Rights Reserved.

- a. **SMTP Server Address:** Specify the SMTP server address used to send outgoing messages. Outgoing messages include event and other alarm information.
- b. **SMTP Email Address from:** Specify the email address that will appear in the From field for messages sent by the ICPAM appliance. This email address is also the Reply To address.
- c. **Test:** Click the Test button to send a test message and verify the SMTP settings. The test message is sent to the administrator email address entered in User settings.
- d. Click **Next** to apply the settings and continue.

**Step 7** Specify the Date and Time settings. Specify an initial date and time for the server. These settings are used by the appliance and the Cisco Physical Access Gateways. Specify the same settings on the active and standby appliance.

Figure 2-6 ICPAM Server Initial Setup: Date &amp; Time Configuration

The screenshot displays the 'Initial Setup' configuration page for the ICPAM server. On the left, a 'Setup Steps' sidebar lists steps 1 through 8, with '6 - Date & Time' highlighted. The main configuration area includes:
 

- Date & Time:** A text input field containing '06/16/15 09:21:39' and a calendar icon.
- Time Zone:** A dropdown menu set to 'America/Los\_Angeles'.
- NTP Enable:** A checked checkbox.
- NTP Server Address\*:** A text input field containing '0.north-america.pool.ntp.oi'.

 At the bottom of the form are three buttons: '< Back', 'Next >', and 'Cancel'. The top right of the page shows 'Welcome', 'Log Out', 'About', and 'Help' links. The footer contains the copyright notice: 'Copyright © 2015 Identiv, Inc. All Rights Reserved.'

- e. **Date & Time:** Click the calendar icon to open a pop-up window and select the current day. The current date and time are inserted from your computer's date and time settings.
- f. **Time Zone:** Select the time zone where the appliance is installed.
- g. **NTP enable:** Select the check box to enable use of an optional Network Time Protocol server, used to automatically adjust the date and time for the ICPAM appliance.



**Note** We strongly recommend using NTP to synchronize the ICPAM appliance and gateway clocks to ensure correct event and messaging. See the [“Changing the NTP Setting for Multiple Gateways” section on page C-6](#) for more information.

- h. **NTP Server Address:** If NTP is enabled, enter the NTP server IP address.
- i. Click **Next** to apply the settings and continue.

**Step 8** Specify the Event pruning and archiving settings, as shown in [Figure 2-7](#).

- Pruned events are removed from the main events database table and placed in a separate events database, allowing you to reduce the size of the main database while keeping old events accessible on the ICPAM system. Pruned events are not visible in Events & Alarms, but are included in reports. Pruned events are also included in system backups.
  - Archived events are removed from all ICPAM database tables and copied to a compressed file. The file includes a password-protected SQL script, and can be run on an offline database to view the purged events. Archived events are not visible in the Events & Alarms listings or Reports, and are not included in system backups. See the [“Archiving Historical Events” section on page 2-25](#) for more information.
- a. Select the **Pruning** tab ([Figure 2-7](#)), and enter the following settings:



Figure 2-7 ICPAM Server Initial Setup: Event Pruning and Archiving

The screenshot shows the 'Initial Setup' page for 'Connected PAM Server Administration'. The left sidebar lists 'Setup Steps' from 1 to 7, with '7 - Event' selected. The main content area has two tabs: 'Pruning' (active) and 'Archive'. Under 'Pruning', there are the following fields:

- Live Event Window(days): 30
- Schedule:
  - Date: [dropdown]
  - Weekday: [dropdown]
  - Daily:
- Time: 00:00:00 (hh:mm:ss)
- Pruning Hours: 1.0

At the bottom of the form are three buttons: '< Back', 'Finish >', and 'Cancel'. The footer contains the copyright notice: 'Copyright © 2015 Identiv, Inc. | All Rights Reserved.'

- **Live Events Window (days)**—Specify a value between 0 and 500 (inclusive). This is the minimum number of days the events will be available in the live view. The default is 30 days. After the minimum number of days the events will be removed at the next scheduled pruning. For example, enter 30 to keep events in the live view for 30 days. After midnight on day 30, the events are subject to pruning and archiving (depending on the schedule defined in the following steps).
- The **Pruning Hours** field is enabled only when you select **Daily** in **Schedule**. The default value is one.

Figure 2-8 ICPAM Server Initial Setup: Pruning Hours

This screenshot is identical to Figure 2-7, showing the 'Initial Setup' page for 'Connected PAM Server Administration'. The 'Pruning' tab is active, and the 'Daily' schedule option is selected. The 'Pruning Hours' field is set to 1.0. The 'Time' field is set to 00:00:00. The 'Live Event Window' is set to 30 days. The 'Schedule' options are 'Date', 'Weekday', and 'Daily' (selected). The 'Pruning Hours' field is enabled and set to 1.0. The footer contains the copyright notice: 'Copyright © 2015 Identiv, Inc. | All Rights Reserved.'

- For other options in Schedule, the Pruning Hours field is read-only. See [Figure 2-7](#).

**Note**

- To ensure that events are regularly pruned, we recommend entering 30 days or less in the **Live Events Window** field. Entering a value greater than 30 can cause an excessive number of event entries to accumulate in the main database and negatively impact system performance.
- The number is rounded to midnight of the last day.

- **Schedule**—define the time and frequency when events should be pruned.
  - **Date**—To schedule pruning for one day per month, select **Date** and then select a day of the month. For example: 15.
  - **Weekday**—To schedule pruning once per week, select **Weekday** and then select a day of the week. For example: Tuesday.
  - **Daily**—To run pruning every day, select **Daily**.
  - **Time**—Enter the time in 24 hour format (hh:mm:ss). For example, to run pruning at 2 p.m., enter 14:00:00. To run pruning at 1 a.m., enter 01:00:00.
- b. Select the **Archive** tab (Figure 2-9) and enter the following settings:

Figure 2-9 ICPAM Server Initial Setup: Archiving Events

The screenshot shows the 'Initial Setup' page for ICPAM Server Administration. The 'Archive' tab is selected. The form contains the following fields and options:

- Password:** [Redacted]
- Re-enter Password:** [Redacted]
- Historic Event Window(days):** 60
- Schedule:**
  - Date: 1
  - Weekday: [Dropdown]
  - Daily:
- Time:** 01:01:00 (hh:mm:ss)
- Copy to remote server

Navigation buttons: < Back, Next >, Cancel.

**Tip**

The archive settings are required during the initial setup. After the server is up, you can disable auto-archiving if necessary. See the [“Archiving Historical Events”](#) section on page 2-25.

- Enter and re-enter the administrator **Password**. This password is used to restore the archive file.
- **Historic Events Window (days)**—Enter the number of days that events will be available in the live view. After the minimum number of days the events will be archived to a compressed file. For example, enter 30 to keep events in the live view for 30 days. After midnight on day 30, the events are subject to archiving (depending on the schedule defined in the following steps).

- Enter a **Schedule** when the historic events will be removed from the pruned database and placed into a compressed archive file (archived files are listed above the entry fields).
  - **Date**—To schedule archiving for one day per month, select **Date** and then select a day of the month. For example: 15.
  - **Weekday**—To schedule archiving once per week, select **Weekday** and then select a day of the week. For example: Tuesday.
  - **Daily**—To run archiving every day, select **Daily**.
  - **Time**—Enter the time in 24 hour format (hh:mm:ss). For example, to run archiving at 2 p.m., enter 14:00:00. To run archiving at 1 a.m., enter 01:00:00.
- (Optional) Select **Copy to remote server** to automatically copy the archived event files to a remote FTP or SFTP location.



---

**Note** Only the three most recent archive files are saved. If you do not save the archive file manually or by copying it to a remote server, then the oldest file will be permanently deleted when the fourth file is created.

---

- **FTP**—for standard File Transfer Protocol servers.
  - **SFTP**—for secure file transfers using the Secure File Transfer Protocol (also known as the SSH File Transfer Protocol).
  - **Address**—the IP address or hostname of the remote server.
  - **Username**—the username required to log in to the server.
  - **Password**—the login password for the remote server.
  - **Path**—the directory path where the compressed archive will be copied. The path must exist on the remote server. If the directory is not available, the archive will fail.
- c. Click **Next** to apply the settings and continue.



---

**Tip** Pruning and Archiving schedules must not overlap each other.

---

**Step 9** Install the software license.



---

**Note** The License option only appears before this copy of ICPAM is registered. After the license for this software is authenticated, the option no longer appears.

---

Figure 2-10 ICPAM Server Initial Setup: License Installation

The screenshot displays the 'Connected PAM Server Administration' web interface. The top navigation bar includes the Identiv logo, the title 'Connected PAM Server Administration', and user options: 'Welcome', 'Log Out', 'About', and 'Help'. A secondary bar contains 'Webapp Log' and 'Show Tech'. The main content area is titled 'Initial Setup' and features a 'Setup Steps' sidebar on the left with a list of steps: 1 - Server, 2 - User, 3 - Network, 4 - DNS, 5 - Email, 6 - Date & Time, 7 - Event, and 8 - License (which is currently selected). The main panel shows a 'File:' input field with a 'Browse...' button. Below the input field are three buttons: '< Back', 'Finish', and 'Cancel'. At the bottom of the page, a copyright notice reads 'Copyright © 2015 Identiv, Inc. | All Rights Reserved.'

**Note**

Enter all licenses except high availability (HA) on the active appliance. Enter only the HA license on the standby appliance. See [Licenses in a Redundant Configuration, page 2-45](#) for more information. See also [Licensing: Frequently Asked Questions, page E-1](#).

- a. Locate the Product Authorization Key included with the ICPAM Manager appliance or purchased separately. See [Obtaining and Installing Optional Feature Licenses, page 2-45](#).
- b. In a Web browser, open the Identiv Product License Registration Web page.  
<http://www.identiv.com/go/license/>
- c. Follow the onscreen instructions to complete the form and enter the Product Authorization Key (PAK). When you are done, a license file with the extension `.lic` is sent to your email address.
- d. Transfer the file to the drive of the PC used for the configuration.
- e. In the License screen ([Figure 2-10](#)), click **Browse** to select the license file located on your local drive. when you select the file, the file name appears in the File field.
- f. Select **Finish** to install the license file on the ICPAM appliance and activate the features.

**Step 10**

When you click **Finish**, the initial installation is applied, as shown in [Figure 2-11](#). Click **Done** when all fields read `Done`.

**Note**

If any errors occur, the setup returns to [Step 2](#). If a serious error occurs, contact your Identiv support representative for assistance.

Figure 2-11 ICPAM Server Initial Setup: Setup Progress

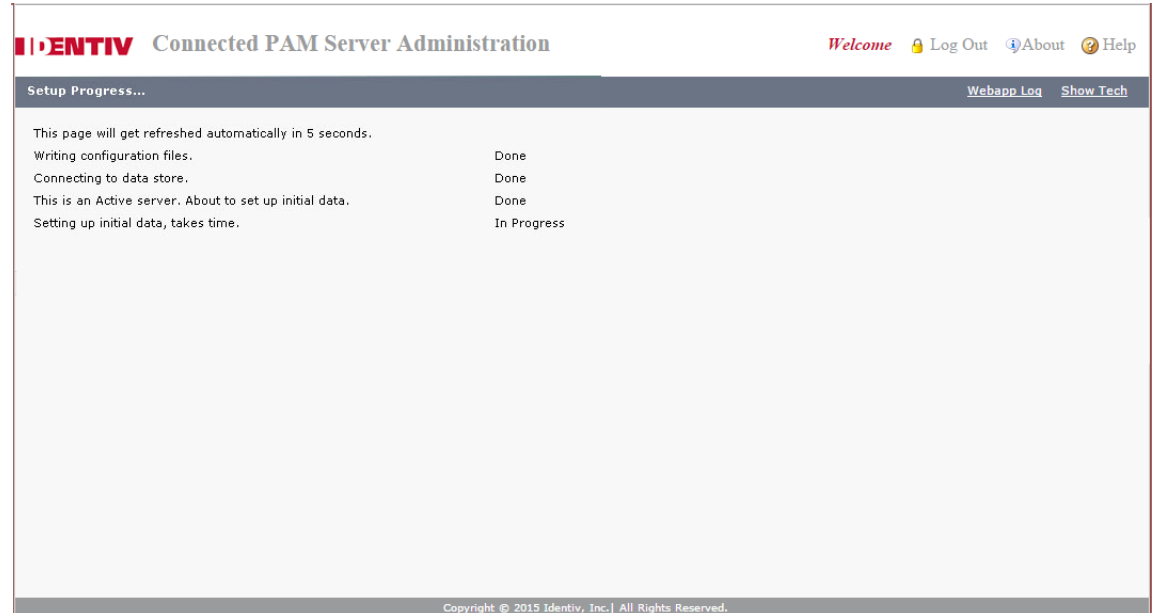

- Step 11** Create a system backup as described in [Appendix A, “Backing Up and Restoring Data”](#). You should have at least one backup file to preserve critical system data. You also must have at least one backup to restore the server software using the recovery CD.
- Step 12** Disconnect your PC from the Eth0 port and connect the Eth0 port to the IP network.

## Configuring ICPAM on a Virtual Machine (VM)

The ICPAM is configured virtually on VMware. The VMware is installed in the UCS server by the UCS admin. Once connected to the VMware the initial setup screens appear automatically when you boot the ICPAM appliance for the first time, (or after a complete system restore). The instructions in this section are for a standalone server, or for the two servers in a redundant (high availability) configuration.

- [Before You Begin, page 2-5](#)

### Before You Begin

Before you power on the ICPAM appliance, you need the following:

- A PC with a Web browser (Internet Explorer 8.0 or higher).

In addition, gather the following information:

- An IP address to launch ICPAM in VMware.



**Note**

Ensure that the VMware is already created through Vsphere client and the IP address is received.

- IP, subnet, and gateway addresses for the ICPAM appliance:
  - For a standalone server installation, one IP address for Eth0 is required.
  - For a redundant (HA) server configuration, three IP addresses are required: One address for the active server, a second address for the standby server, and a third Shared IP Address setting.
  - (Optional) If using NTP synchronization, the address of the NTP server.
- (Optional) The DNS server settings.
- (Optional) If event archives will be backed up to a remote server: an FTP or SFTP server address, a username, and a password.
- Administrator password. If you are setting up the appliance for the first time, use the default password of **cpamadmin**.

## Configuration Procedure

---

**Step 1** Open a Web browser on your PC and enter an URL with the format of: `https://<<icpam IP address>>`



**Note** Be sure to include the *s* in `https://`. This connects your browser to the secure URL.

---

**Step 2** Enter the default username and password as shown in [Figure 2-1](#):

default username: **cpamadmin**

default password: **cpamadmin**

**Step 3** Follow the remaining steps in the setup process. For more information, see [Initial Setup Instructions, page 2-7](#).

---

# Using the Web Admin Menus, Commands, and Options

After the initial setup is complete, you can log into the ICPAM Server Administration utility to monitor the appliance or modify the configuration. The utility also includes commands to perform tasks such as rebooting the server, backing up data, and installing additional software. You can log in to the administration utility using either a direct connection, or through the Internet using the IP address configured for the Eth0 or Eth1 port.

Refer to the following topics for more information:

- [Accessing the ICPAM Server Administration Utility, page 2-19](#)
- [Menus and Options in the ICPAM Server Administration Utility, page 2-20](#)
- [Archiving Historical Events, page 2-25](#)
- [Installing and Revising Language Packs, page 2-30](#)
- [Changing or Recovering the Server Password, page 2-40](#)
- [Obtaining and Installing Optional Feature Licenses, page 2-45](#)
- [Displaying the ICPAM Appliance Serial Number, page 2-48](#)
- [Performing a Graceful Failover with Redundant Appliances, page 2-49](#)

## Accessing the ICPAM Server Administration Utility

To access the ICPAM Server Administration utility, do the following:

- 
- Step 1** Log on to the appliance over the Internet or by using a direct connection:
- For a direct connection, see [Connecting a PC to the Appliance, page 2-5](#).
  - For an Internet connection, open a Web browser and enter the IP address used for the ICPAM Server Administration utility. See [Logging on to the ICPAM Server Administration Utility, page 2-2](#), or ask your system administrator for assistance.



---

**Note** The administration screens also appear immediately following the initial setup.

---

- Step 2** Select a menu from the tabs along the top of the window, as shown in [Figure 2-12](#). Each tab includes additional selections on the left, or additional drop-down menus.
- Step 3** Select an option or command as described in the “[Menus and Options in the ICPAM Server Administration Utility](#)” section on [page 2-20](#).
- Step 4** For settings in the Setup menus, click **Update** to activate the changes.

Figure 2-12 ICPAM Server Administration Utility: Setup Menus

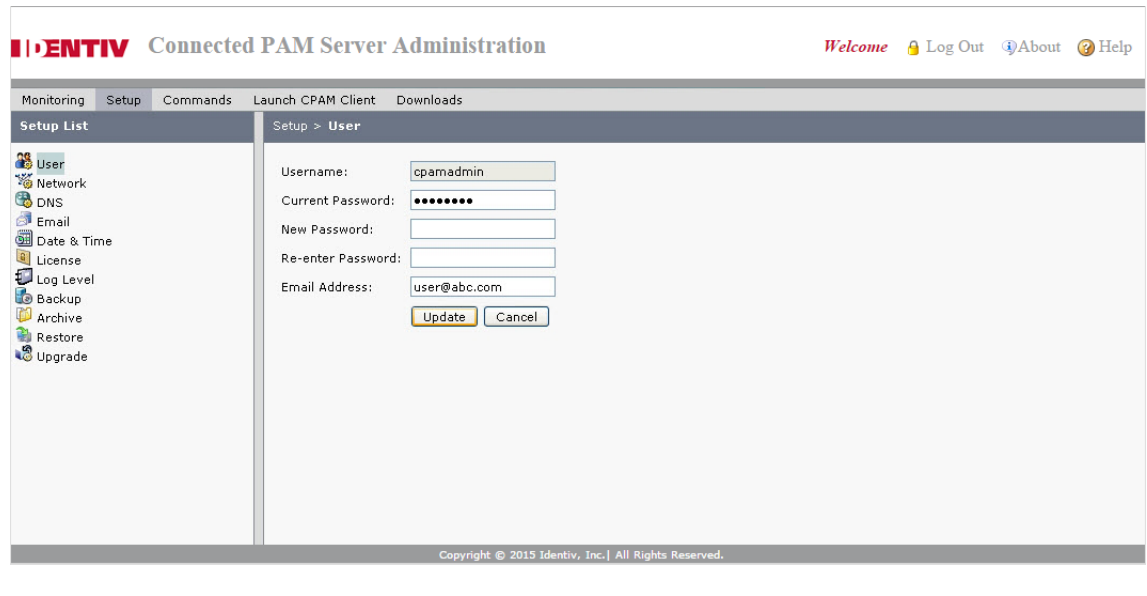

## Menus and Options in the ICPAM Server Administration Utility

The following sections describe the configuration, administration, and monitoring tasks available in the ICPAM Server Administration utility.

- [Monitoring, page 2-21](#)
- [Setup, page 2-22](#)
- [Commands, page 2-23](#)
- [Launch Client, page 2-24](#)
- [Downloads, page 2-24](#)



## Monitoring

*Monitoring* displays the current and past state of the server, and includes the following submenus.

**Table 2-1** *Monitoring Menu*

Menu	Description
<b>Status</b>	<p>Displays real-time information about the current state of the ICPAM appliance and the optional high availability feature. Includes the server software version and serial number. Also includes options to stop or start services, including the following:</p> <ul style="list-style-type: none"> <li>• <b>Admin State:</b> <i>Up</i> means the appliance is available for use. <i>Down</i> means the appliance is unavailable for access control functions. This enables you to take the server offline for administrative functions and updates without actually shutting down the server.</li> <li>• <b>Server Mode:</b> In an HA configuration, the server mode can be either <i>Active</i> or <i>Standby</i>. See the “<a href="#">Using Redundant Appliances for High Availability</a>” section on page 2-2.</li> <li>• <b>Version:</b> The release number of the current ICPAM appliance server software.</li> <li>• <b>Serial Number:</b> the serial number of the ICPAM appliance. For example, 00151729764C.</li> <li>• <b>High Availability Audit:</b> If HA is configured, the audit is enabled.</li> <li>• <b>Peer Address:</b> The IP address of the HA server paired with the current server. For example, 192.168.2.1.</li> <li>• <b>Peer Hostname:</b> The hostname of the HA server paired with the current server. For example, CPAM-75.</li> <li>• <b>Synchronization Status:</b> the status of the HA synchronization process. The options are: <ul style="list-style-type: none"> <li>– <b>Synchronized:</b> HA synchronizations were completed without errors.</li> <li>– <b>Failed to retrieve the Status:</b> An error occurred while retrieving the Sync status. For example, the peer server is down or unreachable. See the <code>webapp.log</code> file for details.</li> <li>– <b>Stopped:</b> the appliance is in Admin <i>Down</i> state, and HA synchronization is stopped.</li> <li>– <b>Error:</b> An error was detected during synchronization. Additional details are displayed with the <i>Error Code</i> and <i>Error String</i> retrieved from the database.</li> <li>– <b>In-progress:</b> The synchronization process is in progress. At least one synchronization actions has not completed.</li> </ul> </li> <li>• <b>TFTP Service:</b> Determines if the TFTP service is available for updating firmware images. See the “<a href="#">Upgrading Gateway Firmware Images Using ICPAM</a>” section on page C-11 and the “<a href="#">Disabling the ICPAM TFTP Server</a>” section on page D-2.</li> <li>• <b>Web Service API:</b> Determines if ICPAM Web services are available. See the <a href="#">Cisco Physical Access Control API Reference Guide</a> for more information.</li> </ul>
<b>Server Log</b>	Displays real-time information regarding server tasks.
<b>Setup Log</b>	Displays real-time information regarding server setup tasks performed on the appliance.
<b>Web Application Log</b>	Displays real-time information regarding events related to server administration tasks.
<b>Audit Log</b>	Displays a history of tasks performed by the administrator username.
<b>Console Log</b>	Displays a real-time console log.

Table 2-1 Monitoring Menu (continued)

Menu	Description
High Availability Audit Log	Displays real-time events related to a redundant server configuration.
URL Log	Displays the output (HTTP response) from URL actions.

## Setup

This menu option enables you to view and edit the server configuration using the following submenus.



Note

Click **Update** to save and activate your changes.

Table 2-2 Setup Menu

Menu	Description
User	The username, password, and email address of the administrator login.
Network	The IP address configuration for the appliance and for the Eth0 and Eth1 network ports. See <a href="#">Entering the Initial Server Configuration, page 2-5</a> for more information.
DNS	The DNS settings for the appliance, if DNS is used.
Email	<p>The email settings for the appliance, including <b>SMTP Server Address</b> and <b>SMTP Email Address from</b>. These settings are used to send notifications and other information from the server.</p> <ul style="list-style-type: none"> <li>Click <b>Test</b> to send a test message and verify the settings. The test message is sent to the administrator email address entered in the User settings.</li> <li>Select <b>Update</b> to apply the settings.</li> </ul>
Date & Time	<p>The server date and time settings. If a Network Time Protocol (NTP) server is used, click <b>NTP enable</b> and enter the <b>NTP Server Address</b> settings.</p> <p><b>Note</b> We strongly recommend using NTP to synchronize the ICPAM appliance and controller clocks to ensure correct event and messaging. See the <a href="#">“Changing the NTP Setting for Multiple Gateways” section on page C-6</a> for instructions to set NTP on controllers.</p>
License	<p>Displays the Identiv licenses installed on the appliance and enables you to install additional licenses.</p> <ul style="list-style-type: none"> <li><b>Install:</b> Install additional Identiv Connected Physical Access Manager feature licenses. See <a href="#">Obtaining and Installing Optional Feature Licenses, page 2-45</a>.</li> <li><b>Features:</b> Displays the licensed modules currently installed in the appliance.</li> <li><b>Files:</b> Lists the license files installed on the appliance.</li> </ul>
Log Level	Defines the log level for capturing log messages. Select a level for each log subject (such as Security). The log levels are Debug, Info, Warn, Error, and Fatal.
Backup	Creates a compressed backup file of all system and configuration data that can be used to restore a server. See <a href="#">Backing up the ICPAM Database, page A-2</a> .

Table 2-2 Setup Menu (continued)

Menu	Description
<b>Event</b>	Prunes and archives historical events from the ICPAM database. Pruned events are moved to a separate database table. Archived events are saved in a password-protected .zip file. See the <a href="#">Archiving Historical Events, page 2-25</a> for more information.
<b>Restore</b>	Restores data from a backup or archive file. The server must be stopped using <b>Stop Server</b> in the Commands menu. See the “ <a href="#">Restoring a Server Backup File</a> ” section on page A-9.
<b>Upgrade</b>	Upgrades the server software. To upgrade the server, select <b>Stop Server</b> from the Commands menu, click <b>Browse</b> to select an upgrade file, and then click <b>Upgrade</b> . Select <b>Start Server</b> from the Commands menu after the upgrade is complete. See the “ <a href="#">Upgrading the ICPAM Server Software</a> ” section on page B-11.
<b>Localization</b>	Enables you to create and add language packs that display ICPAM menus and other text in a language other than English. You can also display both English and a second language at the same time. See the “ <a href="#">Installing and Revising Language Packs</a> ” section on page 2-30.  <b>Note</b> The server has to be stopped to enable Localization. You need to upload the required language pack, start the server, and download the new client for the server.

## Commands

Provides commands to stop, start, and reboot the server. Also includes commands to gather current information from a running server for use in troubleshooting and monitoring. This menu includes the following commands:

Table 2-3 Commands Menu

Command	Description
<b>Start Server</b>	Enables the ICPAM access control server functions and user logins.
<b>Stop Server</b>	Disables the ICPAM access control server functions. All user logins are denied. The appliance remains in operation and you can still log in to the ICPAM Server Administration utility using a direct connection. To restart the access control server, select <b>Start Server</b> .  <b>Note</b> When the server restarts, a message appears asking if you want to change the database password. Click <b>Cancel</b> or <b>OK</b> . This password is a security measure used for troubleshooting and technical support. It does not impact user operation,  <b>Note</b> All EDI projects run when the ICPAM appliance is stopped and restarted. If you do not want the projects to run after a server restart, stop the project(s) before restarting the server. See <a href="#">Importing, Starting, and Monitoring EDI Projects in ICPAM, page 14-40</a> .
<b>Reboot</b>	Performs a hard reboot of the appliance which restarts the OS and the access control server.
<b>Shut Down</b>	Shuts down the appliance. All access control functions stop unless a standby appliance is installed and configured. To restart the appliance and access control server, you must physically power down and then power on the appliance.

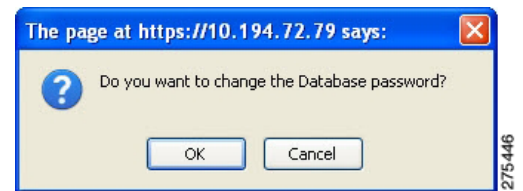

Table 2-3 *Commands Menu (continued)*

Command	Description
<b>Show Technical Support</b>	Collects detailed information and logs for use by Identiv technical support. This command is processor intensive and can result in decreased system performance. Use this command only under the supervision of an Identiv support representative.
<b>Processes</b>	Displays the processes running on the system for use in troubleshooting.

## Launch Client

Launches the ICPAM desktop client. If the client is not installed or is out of date on your workstation, an installation screen appears. Follow the onscreen prompts to install or upgrade the desktop client (if necessary), and launch the application.



### Note

If necessary, the required Java application is also installed. This link is the same as the client installation link on the log in page (Figure 2-2) and in the Downloads menu.

## Downloads

Provides links to download additional software, including the following:

Table 2-4 *Downloads Menu*

Download	Description
<b>JRE 1.7 (Windows)</b>	Installs only the required version of the JRE (Java Runtime Environment) on a Windows PC. JRE 1.7 is now supported for the client.
<b>ICPAM Client (JRE required)</b>	Installs Java, and then installs the ICPAM desktop client. This link is the same as the client installation link on the log in page (Figure 2-2).
<b>Cisco EDI Studio (JRE required)</b>	Installs the EDI studio required to configure data integration. See <a href="#">Chapter 14, “System Integration”</a> for more information. This link is the same as the client installation link on the log in page (Figure 2-2).
<b>SnapShell Driver</b> <b>Snap Shell SDK</b>	Installs the drivers and other software required by the SnapShell scanner. See <a href="#">Using a SnapShell License Scanner to Create Personnel Records, page 9-19</a> .

## Archiving Historical Events

If access control events are allowed to accumulate in the ICPAM database, the storage and backup requirements of the database tables can become unmanageable and affect system performance. To avoid this condition, use the event management feature to automatically *prune* old events from the main ICPAM database, and create compressed *archive* files of historic events. The archive file includes a password-protected SQL script, and can be run on an offline database to view the purged events.

This event management process is defined during initial system setup, as described in the “[Entering the Initial Server Configuration](#)” section on page 2-5. Use the instructions in this section to change the pruning and archiving settings.

This section includes the following topics:

- [Understanding Live, Pruned, and Archived Events](#), page 2-25
- [Pruning and Archiving Historical Events](#), page 2-26

## Understanding Live, Pruned, and Archived Events

Events are stored according to the following categories:

- [Live Events](#)
- [Pruned Events](#)
- [Archived Events](#)

### Live Events

Live events are recent events that are stored in the main ICPAM database table. Live events are visible in Events & Alarms and can be included in system backups.

### Pruned Events

Pruned events are removed from the main events database table and placed in a separate events database, enabling you to reduce the size of the main database while still keeping older events accessible on the ICPAM system. Pruned events are not visible in Events & Alarms, but are included in reports. Pruned events can also be included in system backups.



Tip

---

See the “[Creating Reports from Pruned Events](#)” section on page 12-64

---

The following conditions apply when pruning events:

- Pruning will fail if any events or alarms have pending actions (such as an automated rule). Select the **Clean up queues** command to clear actions for old events or alarms.
- Pruning deletes events from the live events database only if they were copied to the historical events database.
- Alarms are deleted only if all alarm duplicates and annotations are past the live events time.



Tip

---

The pruning process can impact system performance. Schedule pruning to occur during off-peak hours.

---

## Archived Events

Archived events are removed from all ICPAM database tables and copied to a compressed file. The file includes a password-protected SQL script, and can be run on an offline database to view the purged events. Archived events are not visible in the Events & Alarms listings or Reports, and are not included in system backups.

Archiving historic events improves system performance and simplifies monitoring because only the latest and most relevant events and alarms are displayed. System backup file sizes are also reduced. In addition, the historical event records are self-contained. Referenced objects, such as a person's name and card number, are retained even if the original record is deleted. Reports on historical events can also span a much longer time range than is normally possible for live events.

The file name includes the date and the server software version number. For example:

- **bak-04122016-0933561.5.3\_0.3.6.cpam.noevents.zip** is the name of a no-events backup file created 4/12/2016 on a CPAM 1.5.3 system
- **bak-05242016-1452592.2.0\_0.3.8.ICPAM220.zip** is the name of a full backup file created 5/24/2016 on an ICPAM 2.2.0 system

Only the three most recent archive files are saved. When a fourth archive file is added, the oldest file is deleted. You can right click a filename to save it to a local or network drive, or use the option in the following procedure to automatically copy archive files to a remote server.

Archived event files can be restored to ICPAM, if necessary. Restored archive events do not appear in the Event and Alarm Monitoring windows, but you can run reports on them. See the [“Creating Reports from Pruned Events” section on page 12-64](#) for more information. Archived event files can also be used by other applications to view old events or run reports.

## Pruning and Archiving Historical Events

Event management settings are specified during the initial server setup, as described in the [“Entering the Initial Server Configuration” section on page 2-5](#). Use the following procedure to revise the pruning and archiving settings.

- 
- Step 1** Log on to the ICPAM Server Administration utility, as described in the [“Logging on to the ICPAM Server Administration Utility” section on page 2-2](#).
  - Step 2** Choose **Setup** and then **Event** (Figure 2-13).

Figure 2-13 Pruning Events

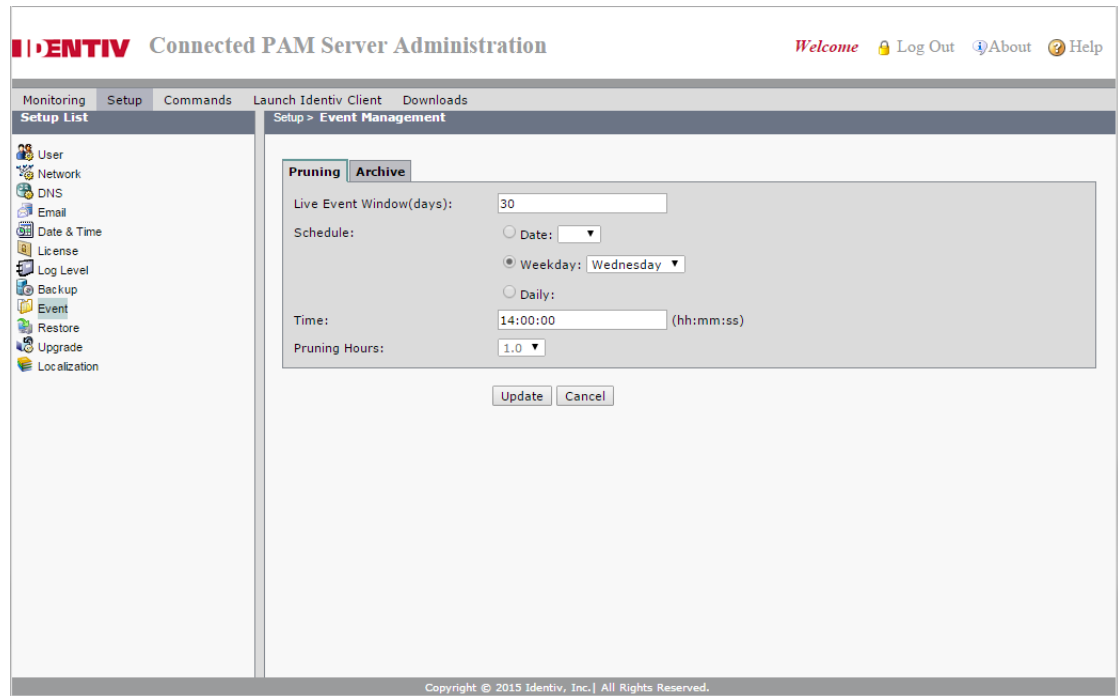

**Step 3** Select the **Pruning** tab, and specify the following settings:

- a. **Live Events Window (days)**—Enter a value between 0 and 500 (inclusive). This is the number of days of events that will be available on live view. All the events older than the specified days will be removed at the pruning schedule time. For example, enter 30 to keep events in the live view for 30 days. After midnight on day 30, the events are subject to pruning and archiving (depending on the schedule defined in the following steps).



**Note**

- To ensure that events are regularly pruned, we recommend entering 30 days or less in the **Live Events Window** field. Entering a value greater than 30 can cause an excessive number of event entries to accumulate in the main database and negatively impact system performance.
- The number is rounded to midnight of the last day.

- b. **Schedule**—define the time and frequency when events should be pruned.
  - **Date**—To schedule pruning for one day per month, select **Date** and then select a day of the month. For example: 15.
  - **Weekday**—To schedule pruning once per week, select **Weekday** and then select a day of the week. For example: Tuesday.
  - **Daily**—To run pruning every day, select **Daily**.
  - **Time**—Enter the time in 24 hour format (hh:mm:ss). For example, to run pruning at 2 p.m., enter 14:00:00. To run pruning at 1 a.m., enter 01:00:00.
- c. **Pruning Hours**— This field is enabled only when Daily is selected in Schedule. The default value is one.

**Note**

The **Pruning Hours** field was added in the CPAM 1.5.1 release.

d. Click **Update** to save the changes.

**Step 4** Select the **Archive** tab (Figure 2-14) and specify the archive settings.

**Figure 2-14** Archiving Events

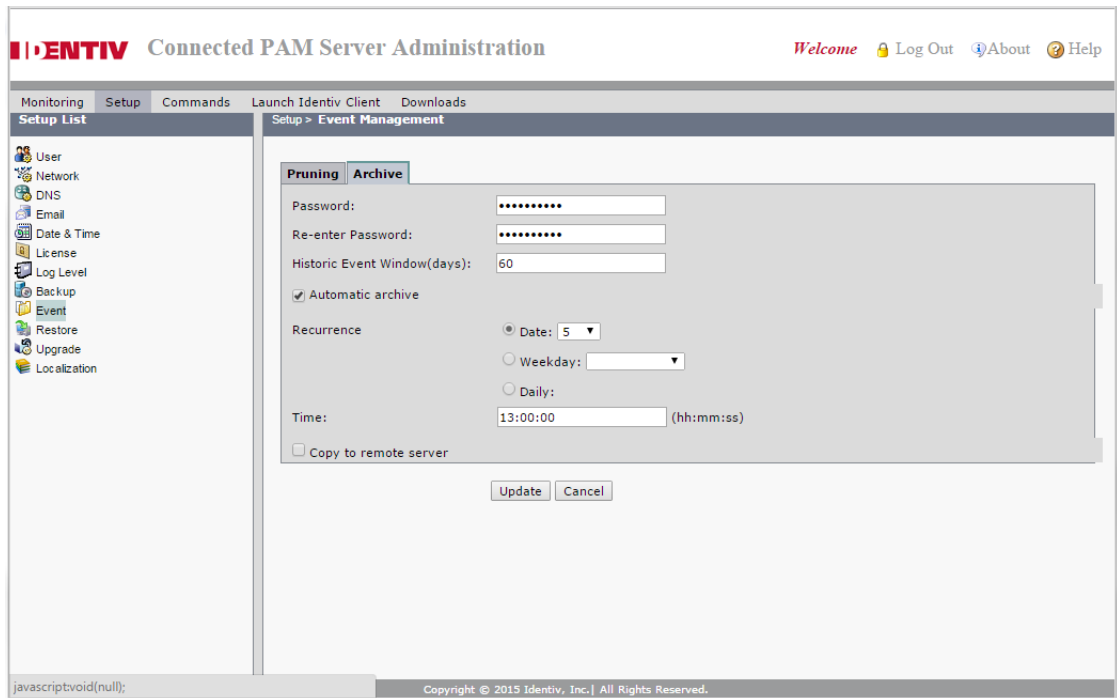
**Note**

- Compressed files containing archived events are listed above the entry fields. The file name includes the archive date & time. For example: `March 01, 2011 11:16:08 AM PDT`.
- Only the three most recent archive files are saved. When a fourth archive file is added, the oldest file is deleted. You can right-click on a filename to save it to a local or network drive, or use the option in the following procedure to automatically copy archive files to a remote server.

The file name includes the date and the server software version number. For example:

- `bak-04122016-0933561.5.3_0.3.6.cpam.noevents.zip` is the name of a no-events backup file created 4/12/2016 on a CPAM 1.5.3 system
- `bak-05242016-1452592.2.0_0.3.8.ICPAM220.zip` is the name of a full backup file created 5/24/2016 on an ICPAM 2.2.0 system
- *No of Historical Events* are the number of historical pruned events that were pruned from the main database table. See the “[Understanding Live, Pruned, and Archived Events](#)” section on page 2-25.

- a. Enter and re-enter the administrator **Password**. Enter and re-enter the administrator **Password**. This password is used to restore the archive file (similar to backup files).



- b. **Historic Events Window (days)**—Enter the number of days that events will be available for reports. After the minimum number of days the events will be archived to a compressed file. For example, enter 30 to keep events in the live view for 30 days. After midnight on day 30, the events are subject to archiving (depending on the schedule defined in the following steps).
- c. Select **Automatic Archive** to enter a schedule when the historic events will be removed from the database and placed into a compressed archive file (archived files are listed above the entry fields).

**Tip**

De-select **Automatic Archive** to run manual archive operations only, or to disable archiving on the standby appliance in an HA configuration.

- **Date**—To schedule archiving for one day per month, select **Date** and then select a day of the month. For example: 15.
  - **Weekday**—To schedule archiving once per week, select **Weekday** and then select a day of the week. For example: Tuesday.
  - **Daily**—To run archiving every day, select **Daily**.
  - **Time**—Enter the time in 24 hour format (hh:mm:ss). For example, to run archiving at 2 p.m., enter 14:00:00. To run archiving at 1 a.m., enter 01:00:00.
- d. (Optional) Right-click an archived filename and select a save option from the browser menu.
  - e. (Optional) Select **Copy to remote server** to automatically copy the archived event files to a remote FTP or SFTP location.

**Note**

Only the three most recent archive files are saved. If you do not save the archive file manually or by copying it to a remote server, then the oldest file will be permanently deleted when the fourth file is created.

- **FTP**: for standard File Transfer Protocol servers.
- **SFTP**: for secure file transfers using the Secure File Transfer Protocol (also known as the SSH File Transfer Protocol).
- **Address**—the IP address or hostname of the remote server.
- **Username**—the username required to log in to the server.
- **Password**—the login password for the remote server.
- **Path**—the directory path where the compressed archive will be copied. The path must exist on the remote server. If the directory is not available, the archive will fail.

**Note**

If the IP address, username, password, or path is incorrect, or if the server is not available, then the backup is not copied to the remote server. The backup is still created on the ICPAM server.

- f. Click **Update** to save the changes.

## Installing and Revising Language Packs

Optional language packs can be installed on the ICPAM appliance to display ICPAM menus and other text in a language other than English. You can install more than one language pack, and users can select one of those languages from a drop-down list when logging in to the ICPAM application (Figure 2-15). Users can also select the *Dual-language mode* option to display text and menus in both English and the selected language.

Figure 2-15 Log In dialog with Language options

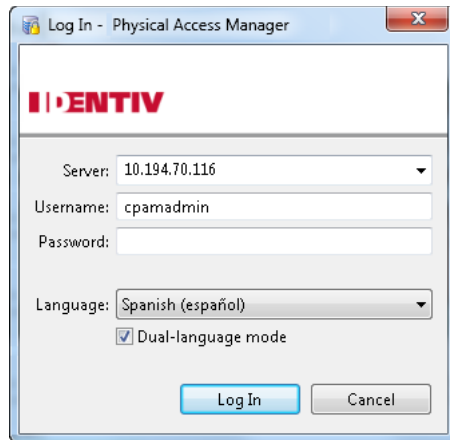

You can create a new language pack or edit an installed language pack, by downloading and editing a set of XML files.

### Usage Notes

- If you upgrade the ICPAM appliance from CPAM release 1.2.0 or lower to release 1.3.0 or higher, you must also upgrade the system database to support localization. This is a one-time process performed by clicking an *Enable Localization* button the first time you access the localization feature. This procedure is also required if you restore a data backup from release CPAM 1.2.0 or lower to release 1.3.0 or higher. This process can take up to one hour (or more) to complete for large databases. See the [Creating or Revising a Language Pack, page 2-30](#).
- Log files and the ICPAM Server Administration utility appear in English even if a language pack is installed.

### Creating or Revising a Language Pack

To create a new language pack translation, download a set of XML template files for the language you want to use. You can download and edit a language pack that was previously uploaded, or download and edit a new set of template files.

Next, edit the XML files to include the translated text you want to appear in the ICPAM desktop application. Then save the revised files using the same filename and compress the directory containing the XML files.



#### Note

The directory and compressed .zip archive can have any name you choose, but the XML files contained in that compressed .zip file must have the same filenames as the originals.

Import the compressed language pack file into the ICPAM appliance using the ICPAM Server Administration utility. Finally, reinstall the ICPAM desktop application, which includes the new language pack.

Editing a language pack that was previously installed is the same process as creating a new language pack. Instead of downloading a new template, however, you download and edit the language pack files that were previously installed.

### Procedure

Perform the following procedure to create or edit a language pack for any language.

- 
- Step 1** Log on to the appliance over the Internet or by using a direct connection:
- For a direct connection, see [Connecting a PC to the Appliance, page 2-5](#).
  - For an Internet connection, open a Web browser and enter the IP address used for the ICPAM Server Administration utility. See [Accessing the ICPAM Server Administration Utility, page 2-19](#), or ask your system administrator for assistance.
- Step 2** (Optional) Perform a system backup, as described in [Appendix A, “Backing Up and Restoring Data”](#).
-  **Tip** To ensure the integrity of your existing data, back up system data before performing any major operation.
- 
- Step 3** Select **Setup**, and then select **Localization** ([Figure 2-16](#)).
- Step 4** Enable localization, if necessary ([Figure 2-16](#)):
- This step is only necessary if you are upgrading or restoring data from CPAM release 1.2.0 or lower.
  - If your appliance is a new installation, skip to [Step 5](#). You can also skip to [Step 5](#) if localization was previously enabled on the appliance.

Figure 2-16 Enable Localization



- a. Place the server in the *Down* state.
  - Click the **Monitoring** tab and select **Stop** in the Admin State entry.
  - Verify that the Admin State is *Down*.
- b. Return to the Localization page and click **Enable Localization** (Figure 2-16).
- c. Click **OK** when the confirmation message appears.
- d. Wait for the message *The localization feature is enabled* to appear. This can take up to one hour or more for large databases.

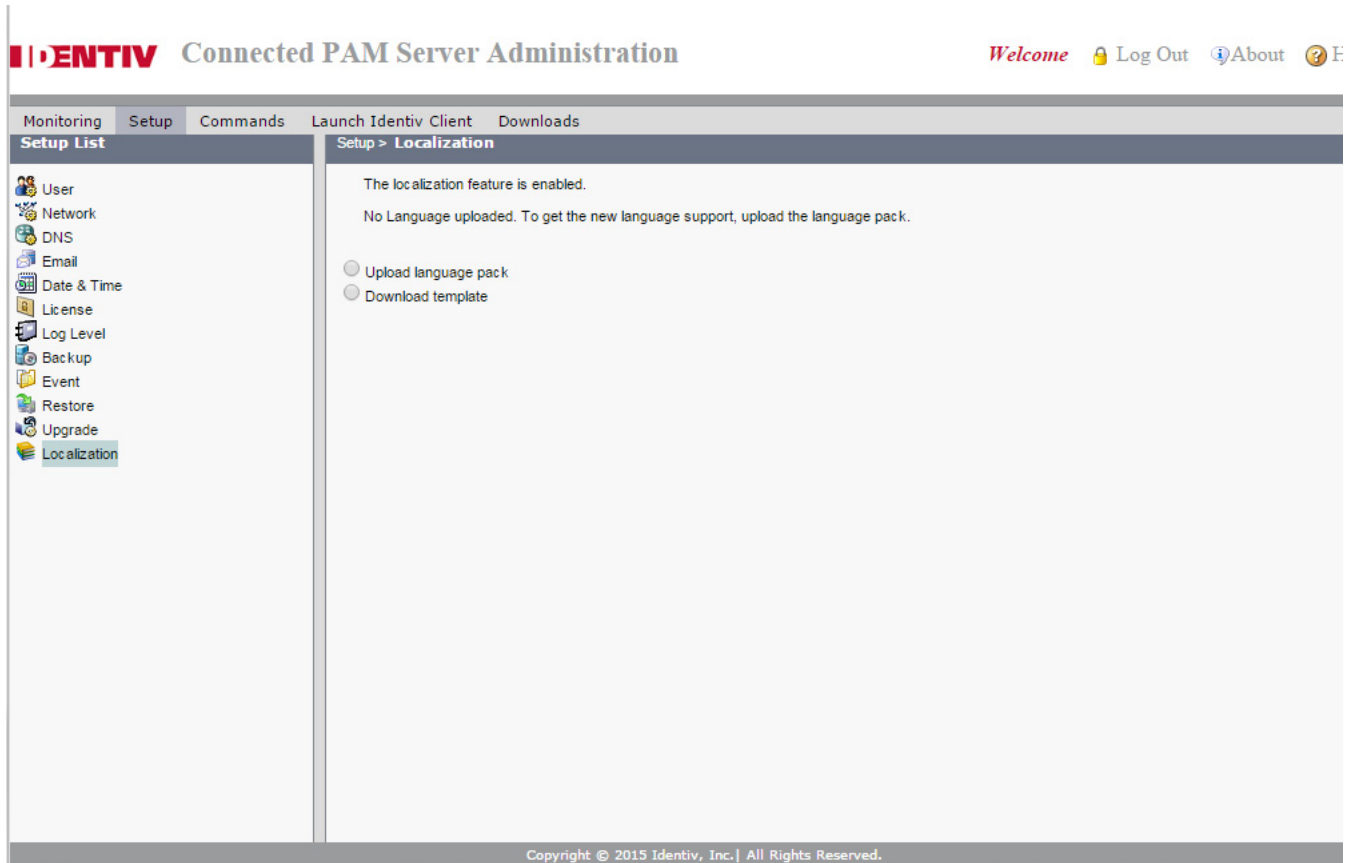

**Tip** The **Upload** and **Download** buttons are also enabled when the conversion process is complete.

- Step 5** To edit an existing language pack, click the **Download** link next to the installed language (Figure 2-17), and skip to [Step 7](#).

Figure 2-17 Localization Menu in the ICPAM Server Administration Utility

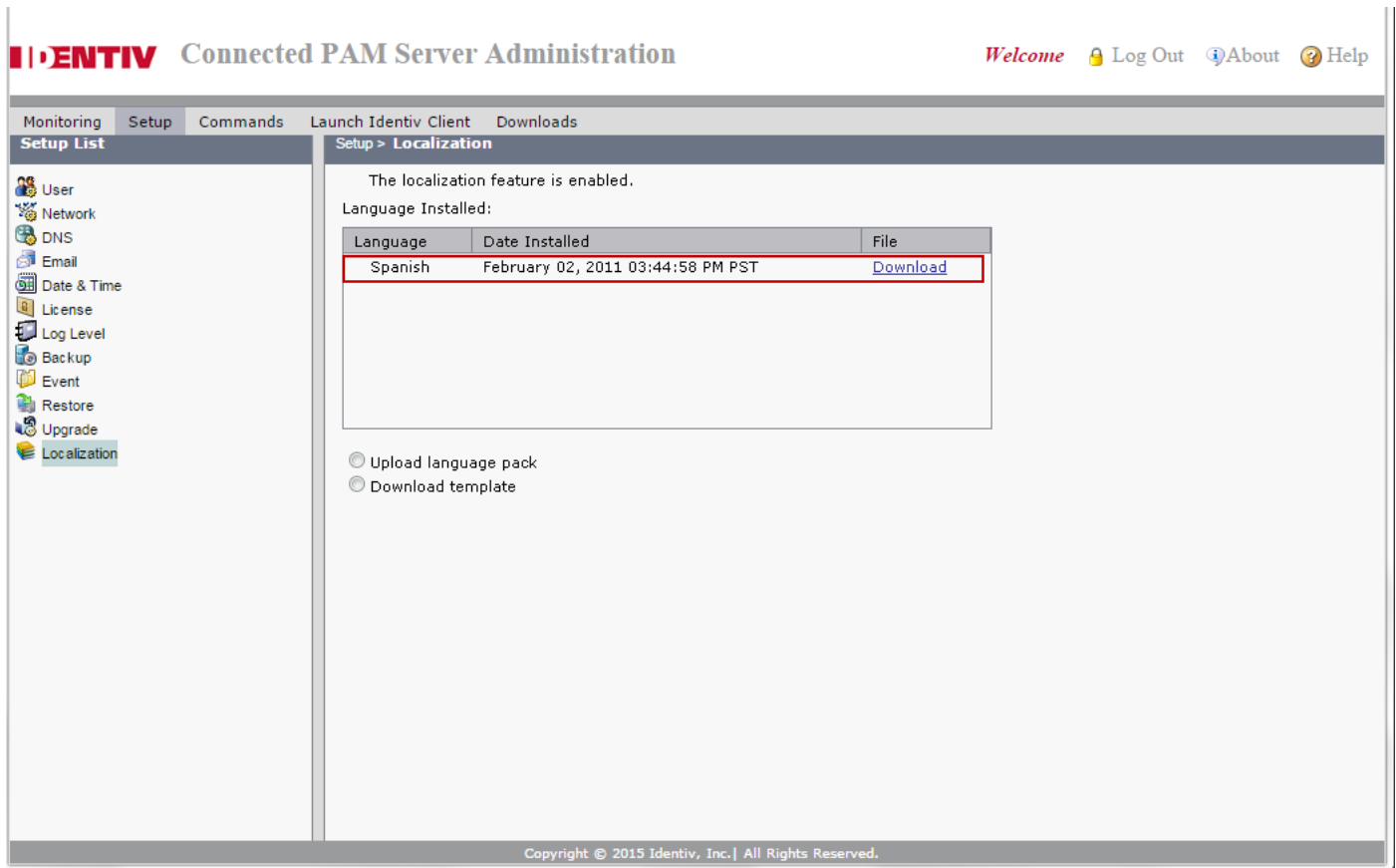

- Step 6** To create a new language pack, download a language template:
- Select the **Download template** radio button (Figure 2-18).
  - Choose a language from the **Language** drop-down list.
  - Select **Download**.
  - Continue to [Step 7](#).

Figure 2-18 Download Language Template option

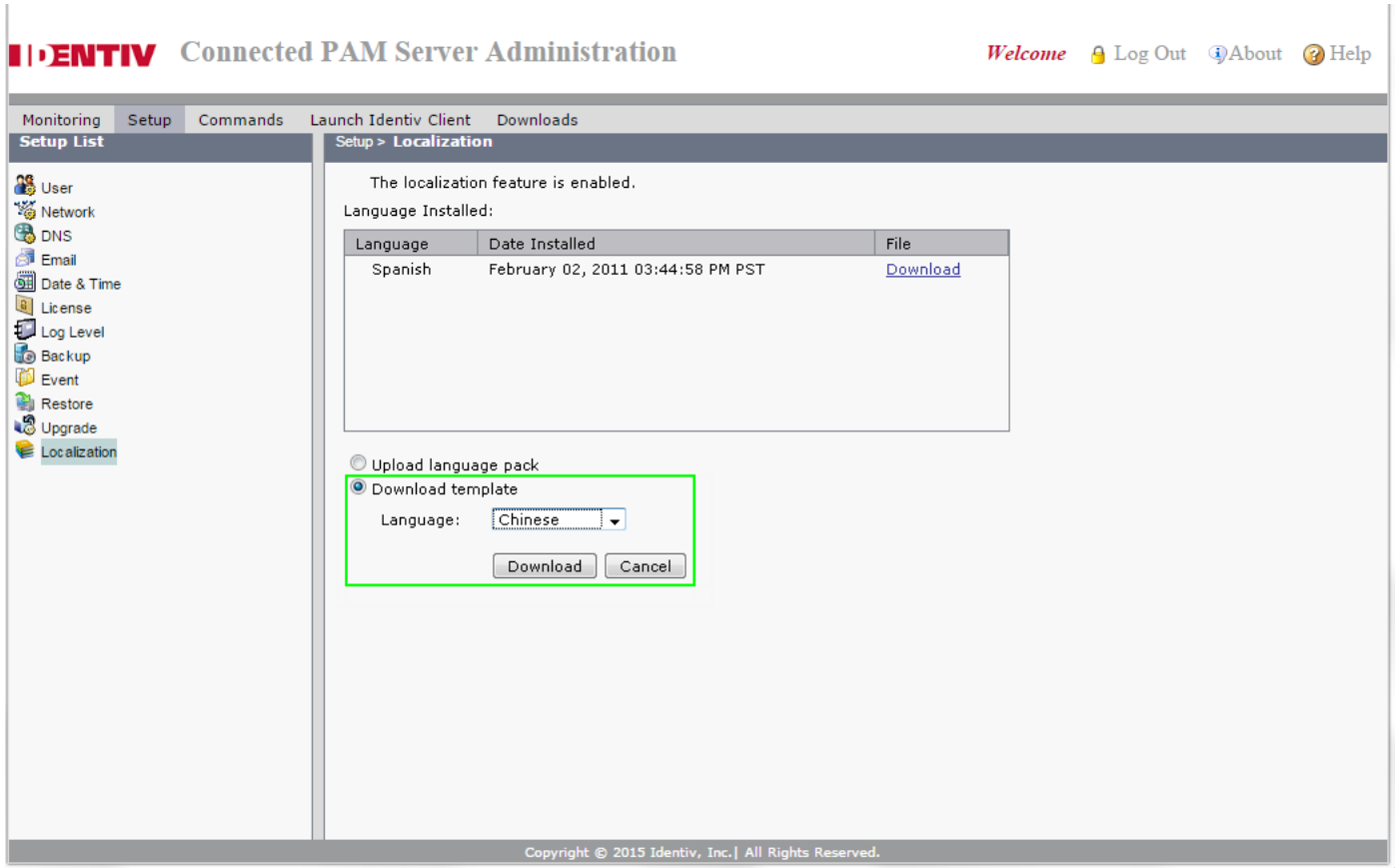

**Step 7** Select a location on your hard drive to save the compressed .zip file.

The filename includes the release number, and language code. For example:

languagepack\_zh\_2.1\_0.3.10

**Step 8** Edit the XML files to include the translated text:

- a. Unzip the compressed language pack directory.
- b. Open each file in a Unicode-supported text editor.

For example: in Windows, right-click on the filename and select **Open with > XML Editor** from the pop-up menu (Figure 2-19).

Figure 2-19 Right-click menu for opening an XML file

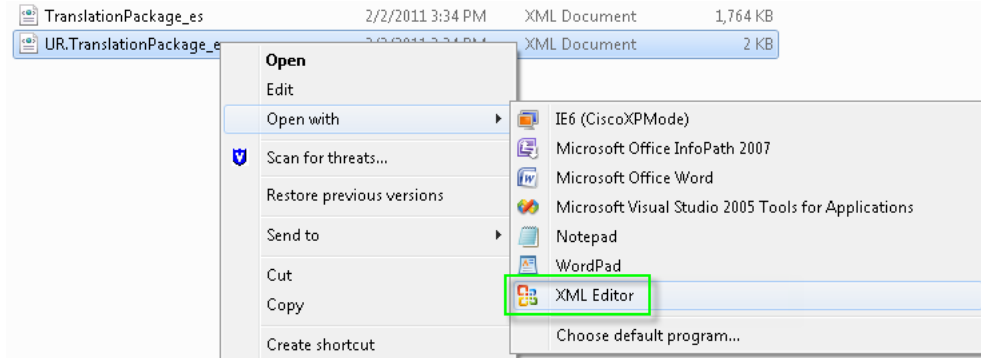

- c. Enter the translated text for each *Translation Unit*.

For each *Translation Unit*, there are two *item* entries: one for English (en), and another for the language you are translating (Figure 2-20).

Figure 2-20 Translation Unit in an XML Language File

```

<?xml version="1.0" ?>
- <TranslationPackage>
  <comments />
- <TranslationUnits>
  - <TranslationUnit>
    <type>ModuleCategory</type>
    <uniqueId>GW.SCHEDULES</uniqueId>
    - <Map id="names">
      - <item>
        <String id="key">en</String>
        <String id="value">Schedule Manager</String> ← English text
      </item>
      - <item>
        <String id="key">es</String>
        <String id="value">Schedule Manager</String> ← Translate this "value".
      </item>
    </Map>
    <comments />
  </TranslationUnit>

```

- **String id “key”** identifies the language. The English (en) entry shows the English text, and an additional “key” entry identifies the language you need to translate. For example, Spanish is represented as “es”. Do not change these “key” values.
- **String id “value”** is the actual text of the item. Replace the English sample with the translated text for your language. This is the text that will appear in the ICPAM application.



## Note

- Do not change the text value of the “en” item. This is the English text which allows both languages to appear in the ICPAM client application.
- The items for English and the second language might appear in a different order, depending on the language pack and XML file. For example, in some XML files, the English entry may appear first. In other files, the second language may appear first. Always verify that you are editing the correct language. Never modify the English (en) *key* or *value*.

- d. Save each XML file using the same filenames as the originals.
- e. Repeat these steps to translate each required XML file in the language pack.

**Step 9** Place the translated language pack files in a directory and compress the directory as a `.zip` archive. The directory and compressed `.zip` archive can have any name you choose, but the XML files contained in that compressed `.zip` file must have the same filenames as the originals.

**Step 10** Place the active and standby ICPAM appliances in the Admin State *Down* state. The server must be in Admin State *Down* to upload the compressed language pack file. If your system includes a redundant standby server, place the standby server in Down state first to prevent a failover.



**Caution** Placing the server in Admin State *Down* stops all ICPAM services. If a redundant Standby server is configured, you must also place the Standby server in the Admin State *Down* state.

- a. Log on to the *standby* ICPAM appliance (if configured).
- b. Select **Monitoring** and then **Status** (Figure 2-21).
- c. Click the **Stop** button (on the right side of the Admin State row).

**Figure 2-21** Stopping the ICPAM Server

The screenshot shows the 'Connected PAM Server Administration' web interface. The top navigation bar includes 'Monitoring', 'Setup', 'Commands', 'Launch Identiv Client', and 'Downloads'. The current page is 'Monitoring > Status'. Under the 'Server' section, the 'Admin State' is 'Up' with a 'Stop' button next to it. Other server details include 'Server Mode: Active', 'Version: 2.0.0', 'Serial Number: 000C29200881', and 'High Availability Audit: disabled'. Under the 'Services' section, 'TFTP Service' is 'Up' with a 'Stop' button, and 'Web Service API' is 'Enabled' with a 'Disable' button. A 'Cisco Compatible' logo is visible in the bottom right corner. The footer contains the copyright notice: 'Copyright © 2015 Identiv, Inc. | All Rights Reserved.'

- d. Log on to the *active* ICPAM appliance.
- e. Select **Monitoring** and then **Status** (Figure 2-21).
- f. Click the **Stop** button (on the right side of the Admin State row).

**Step 11** Upload the revised language pack.

- a. Select **Setup** and then select **Localization**.
- b. Select the **Upload language pack** radio button (Figure 2-22).
- c. Select the **Language** you want to import from the drop-down list.
- d. Click **Browse** and select the compressed file that contains the revised XML files.  
For example: `languagepack_zh_2.1_0.3.10`
- e. Click **Upload**.



Figure 2-22 Applying the Language Pack

Identiv Connected PAM Server Administration Welcome Log Out About Help

Monitoring Setup Commands Launch Identiv Client Downloads

Setup List

- User
- Network
- DNS
- Email
- Date & Time
- License
- Log Level
- Backup
- Event
- Restore
- Upgrade
- Localization

Setup > Localization

The localization feature is enabled.

Language Installed:

Language	Date Installed	File
Spanish	February 02, 2011 03:44:58 PM PST	<a href="#">Download</a>

Upload language pack  
 Download template

Language:

Translation File:

Copyright © 2015 Identiv, Inc. | All Rights Reserved.

- Step 12** Wait for the upload to complete, and click **OK** after the confirmation message appears.
- Step 13** Confirm that the correct language pack was installed (Figure 2-23).

Figure 2-23 Languages Installed on the ICPAM Server

The screenshot shows the 'Identiv Connected PAM Server Administration' web interface. The top navigation bar includes 'Monitoring', 'Setup', 'Commands', 'Launch Identiv Client', and 'Downloads'. The 'Setup' menu is expanded to show 'Localization'. The main content area displays the message 'The localization feature is enabled.' Below this is a table titled 'Language Installed:' with the following data:

Language	Date Installed	File
Chinese	February 13, 2011 04:08:15 PM PST	<a href="#">Download</a>
Spanish	February 02, 2011 03:44:58 PM PST	<a href="#">Download</a>

Below the table are two radio buttons: 'Upload language pack' and 'Download template'. The footer of the page reads 'Copyright © 2015 Identiv, Inc. | All Rights Reserved.'

**Step 14** Restart the ICPAM server.



**Note** The server must be in Admin State *Up* to initialize the language pack and for users to access the system.

- Select **Monitoring** and then **Status**.
- Click the **Start** button (on the right side of the Admin State row).

**Step 15** Download and install the new version of the ICPAM client application.



**Note** The new language will not be available until you uninstall and reinstall the client application.

- If the ICPAM client is already installed on your Windows PC, uninstall it.
  - Go to **Start > Programs > Identiv Connected Physical Access Manager > Uninstaller** and follow the onscreen instructions.
  - Or go to **Start > Control Panel > Uninstall a Program > Identiv Connected Physical Access Manager** and choose **Uninstall**.
- Use one of the following methods to reinstall the desktop client:
  - In the ICPAM Server Administration utility, click **Launch ICPAM Client**.

- Select **Downloads** and then **ICPAM Client (JRE required)**.
- Click **Launch ICPAM Client** on the web utility login page.



**Tip** See the “[Installing or Updating the ICPAM Desktop Software](#)” section on page 3-2 for more information.

- c. Follow the onscreen instructions to install and launch the updated ICPAM client.

**Step 16** Select the new language when logging in to the ICPAM desktop client.

- a. Launch the ICPAM application.
- b. In the **Log In** dialog, choose the language you want to use from the **Language** drop-down list (Figure 2-24).
- c. (Optional) To display both languages in the application, select the **Dual-language mode** option.
- d. Enter the server hostname or IP address, the username, and the password.
- e. Click **Log In**.

**Figure 2-24** Selecting a Language on the ICPAM Log In dialog



**Step 17** Verify that the translated text appears correctly in the ICPAM application (Figure 2-25).

If you chose *Dual-language mode*, the standard English text appears within parentheses after the translated text.

**Figure 2-25** Translated Menus in ICPAM

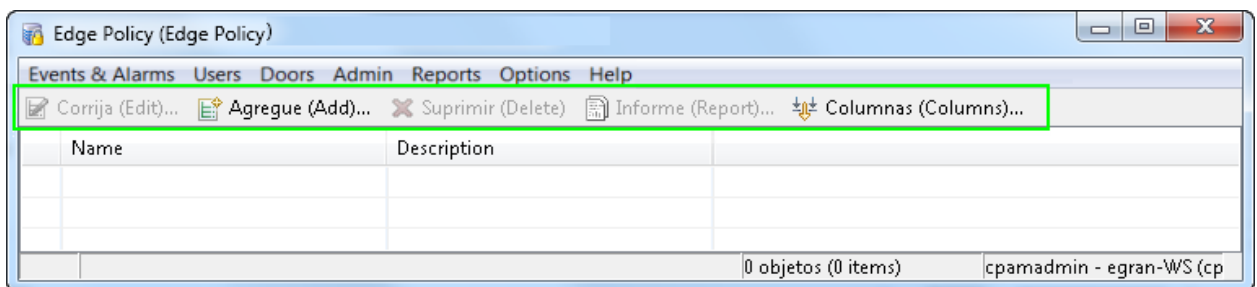

**Tip**

The Login screen (Figure 2-24) also displays the selected language the next time you log in.

- Step 18** If corrections are required, return to [Step 5](#) to download and edit the XML files for an existing language pack. You must uninstall and reinstall the ICPAM client application each time you upload a language pack for the changes to appear.

## Changing or Recovering the Server Password

This section includes instructions to change the server password, or to recover a forgotten password. To recover a forgotten password: click the **Forgot Password?** link on the login page. The **Forgot Password?** link is available only if the server email settings are configured (because the link is used to send an email with password reset instructions).

If the **Forgot Password?** link is not enabled, you must recover the password by reinstalling the server software.

**Note**

- The `cpamadmin` username is the only username supported on the ICPAM Server Administration utility. The `cpamadmin` username cannot be changed and additional usernames cannot be added. The default password (also `cpamadmin`) must be changed during the initial server setup.
- The same `cpamadmin` username and password is automatically created on the ICPAM desktop client during the initial server setup. After the initial server setup, however, the desktop `cpamadmin` username and password is managed separately: changes to the server password do not effect the desktop account. See [Chapter 4, “Configuring User Access for the ICPAM Desktop Client”](#) for more information.

This section includes the following topics:

- [Changing the ICPAM Server Administration Utility Password, page 2-40](#)
- [Resetting a Forgotten Password, page 2-41](#)
- [Recovering a Lost Server Password, page 2-44](#)

## Changing the ICPAM Server Administration Utility Password

To change the password for the `cpamadmin` username on the ICPAM Server Administration utility, do the following:

- Step 1** Log on to the appliance over the Internet or by using a direct connection:
- For a direct connection, see [Connecting a PC to the Appliance, page 2-5](#).
  - For an Internet connection, open a web browser and enter the IP address used for the ICPAM Server Administration utility. See [Logging on to the ICPAM Server Administration Utility, page 2-2](#), or ask your system administrator for assistance.

**Step 2** Select the **Setup** tab and then select the **User** menu, as shown in [Figure 2-26](#).

*Figure 2-26 ICPAM Server Administration Utility: Setup Menus*

**Step 3** Enter the current and new passwords in the appropriate fields.

**Step 4** Click **Update**.



**Note**

Changing the server password does not affect the `cpamadmin` user password for the ICPAM desktop client. See [Chapter 4, “Configuring User Access for the ICPAM Desktop Client”](#) for information on managing desktop client usernames and passwords.

## Resetting a Forgotten Password

To reset a forgotten `cpamadmin` server password, click the **Forgot Password?** link on the login page and complete the following instructions.



**Note**

- The **Forgot Password?** link appears only if the feature is enabled (as described in [Enabling the Forgot Password Feature, page 2-42](#)). If the **Forgot Password?** link does not appear on the login page, follow the instructions in the “[Recovering a Lost Server Password](#)” section on page 2-44.
- The ICPAM server password is different from the ICPAM desktop client password. See [Chapter 4, “Configuring User Access for the ICPAM Desktop Client”](#) for information on managing desktop client usernames and passwords.

To reset a forgotten admin password for the server utility, do the following:

- 
- Step 1** Open the ICPAM Server Administration utility login page.
  - Step 2** Click the **Forgot Password?** link that appears below the Password field.  
When you click this link, an email containing password instructions is sent to the email address configured in the **User** setup page.
  - Step 3** Access that email message using your email application, and click the included URL to open an online reset password form, as shown in [Figure 2-27](#).



**Note** The email's URL is only valid for 30 minutes, or until it is used to reset the password.

---

*Figure 2-27 Reset Password Page*

- Step 4** Enter and reenter your new password, and then click **Update**.
  - Step 5** Log in using the new password.
- 

## Enabling the *Forgot Password* Feature

The **Forgot Password?** link appears on the login page only if the server email settings are configured, as described in the following steps:

- 
- Step 1** Log in to the ICPAM Server Administration utility.
  - Step 2** Enter the email address that will receive **Forgot Password?** emails.
    - a.** Select the Setup tab and then select the User menu, as shown in [Figure 2-28](#).

Figure 2-28 Email Recipient for Forgotten Password

The screenshot displays the web administration interface for the Identiv Connected PAM Server. The page title is "Identiv Connected PAM Server Administration". In the top right corner, there is a "Welcome" message and links for "Log Out", "About", and "Help". The main navigation bar includes "Monitoring", "Setup", "Commands", "Launch Identiv Client", and "Downloads". The "Setup" tab is active, and the "User" sub-tab is selected. On the left side, there is a "Setup List" menu with icons for User, Network, DNS, Email, Date & Time, License, Log Level, Backup, Event, Restore, Upgrade, and Localization. The main content area shows the "Setup > User" configuration form with the following fields and values:

Username:	<input type="text" value="cpamadmin"/>
Current Password:	<input type="password" value="••••••"/>
New Password:	<input type="password"/>
Re-enter Password:	<input type="password"/>
Email Address:	<input type="text" value="mjpelton@gmail.com"/>

At the bottom of the form are "Update" and "Cancel" buttons. The footer of the page reads "Copyright © 2015 Identiv, Inc. | All Rights Reserved."

- b. Enter an **Email Address** that will receive Forgot Password emails.
- c. Click **Update**.

**Step 3** Enter the SMTP settings used to send the Forgot Password emails.

- a. On the Setup tab, click the **Email** menu, as shown in [Figure 2-29](#).

Figure 2-29 Send Email Settings for Forgot Password

The screenshot shows the 'Connected PAM Server Administration' web interface. At the top, there is a navigation bar with 'Monitoring', 'Setup', 'Commands', 'Launch Identiv Client', and 'Downloads'. The 'Setup' menu is expanded to show 'Setup > Email'. On the left, a 'Setup List' sidebar contains icons for various system settings. The main configuration area for 'Email' has two text input fields: 'SMTP Server Address' (containing 'mail.identivlab.com') and 'SMTP Email Address from' (containing 'icpam.identivlab.com'). Below the fields are three buttons: 'Test', 'Update', and 'Cancel'.

- b. Enter the **SMTP Server Address** used to send outgoing messages. Outgoing messages also include event and other alarm information.
- c. Enter an email address in the **SMTP Email Address from** field. This address appears in the `From` field for messages sent by the ICPAM appliance. This email address is also the `Reply To` address.
- d. Click **Test** to verify the settings.
- e. Click **Update** to save the settings.

## Recovering a Lost Server Password

If the `cpamadmin` password is lost and the **Forgot Password?** feature is not enabled, do the following.

- Step 1** Reinstall the server software and enter a new `cpamadmin` password, as described in [Reinstalling the ICPAM Server Software from a Recovery CD, page B-24](#). Reinstalling the ICPAM server software deletes all server information and settings.
- Step 2** Restore the ICPAM data and settings from a backup file, as described in [Appendix A, “Backing Up and Restoring Data”](#).



**Note** The backup file does not include the old password. The password is entered during the restore.



## Obtaining and Installing Optional Feature Licenses

ICPAM client and server software, the Badge Designer, and the Web Services API are all included as part of the ICPAM hardware purchase; there is no need to purchase these as separate feature licenses.

The HA and EDI licenses are the only optional feature licenses.

Customers who purchase the HA or EDI licenses will electronically receive information on how to obtain the license files. Refer to [Table 2-5 on page 2-46](#) for optional feature licenses and part numbers available for purchase.

To enable the HA- or EDI-licensed features:

- 
- Step 1** Start the ICPAM application.
  - Step 2** On the License screen, click **Browse**.
  - Step 3** Find and select the license file located on your local drive.
  - Step 4** Select **Update** to install the license file on the ICPAM appliance and activate the features.
  - Step 5** Select the **Features** tab to verify that the new license has been added.
  - Step 6** Quit and relaunch the ICPAM desktop software to access the new feature menus.



### Note

- The menus for licensed software features do not appear unless the license is installed on the ICPAM appliance.
- If you are installing a new server, or reconfiguring a server after a system restore from a CD/DVD, see [Entering the Initial Server Configuration, page 2-5](#) to install licenses during the initial setup.
- Licenses installed on a ICPAM appliance cannot be transferred to another appliance.
- Licenses installed in an HA configuration are automatically transferred from the active appliance to the standby server during a failover.

---

This section includes the following topics:

- [Licenses in a Redundant Configuration, page 2-45](#)
- [Part Numbers for the Optional Feature Licenses, page 2-46](#)
- [Installing Additional Licenses, page 2-46](#)
- [Displaying the ICPAM Appliance Serial Number, page 2-48](#)
- [Displaying a Summary of Installed Licenses, page 2-47](#)

### Licenses in a Redundant Configuration

If two appliances are installed in a redundant configuration, all installed licenses apply to both the active and standby appliances. If a failover occurs, the standby appliance automatically assumes all active licenses. Only the high availability (HA) license is installed on the standby appliance. All other licenses are installed on the active appliance. See [Entering the Initial Server Configuration, page 2-5](#).

[Table 2-5 on page 2-46](#) lists the part numbers for the optional feature licenses.

## Part Numbers for the Optional Feature Licenses

Table 2-5 lists the part numbers for the optional feature licenses.

**Table 2-5** *Optional Feature Licenses and Part Numbers*

Part	Optional Feature Licence
CIAC-PAME-HA=	ICPAM Manager HA License
CIAC-PAME-EAI=	ICPAM Manager EDI License

For information on how to purchase these optional licenses, contact [sales@identiv.com](mailto:sales@identiv.com).

To contact ICPAM support for technical support information, go to the following link and submit your request via web or contact us: <http://www.identiv.com/support-icpam>.

## Installing Additional Licenses

This section contains instructions on how to download and install additional license files after the ICPAM appliance is set up. If you are installing a new appliance, see [Entering the Initial Server Configuration, page 2-5](#).

**Figure 2-30** *Installing Optional Feature Licenses*

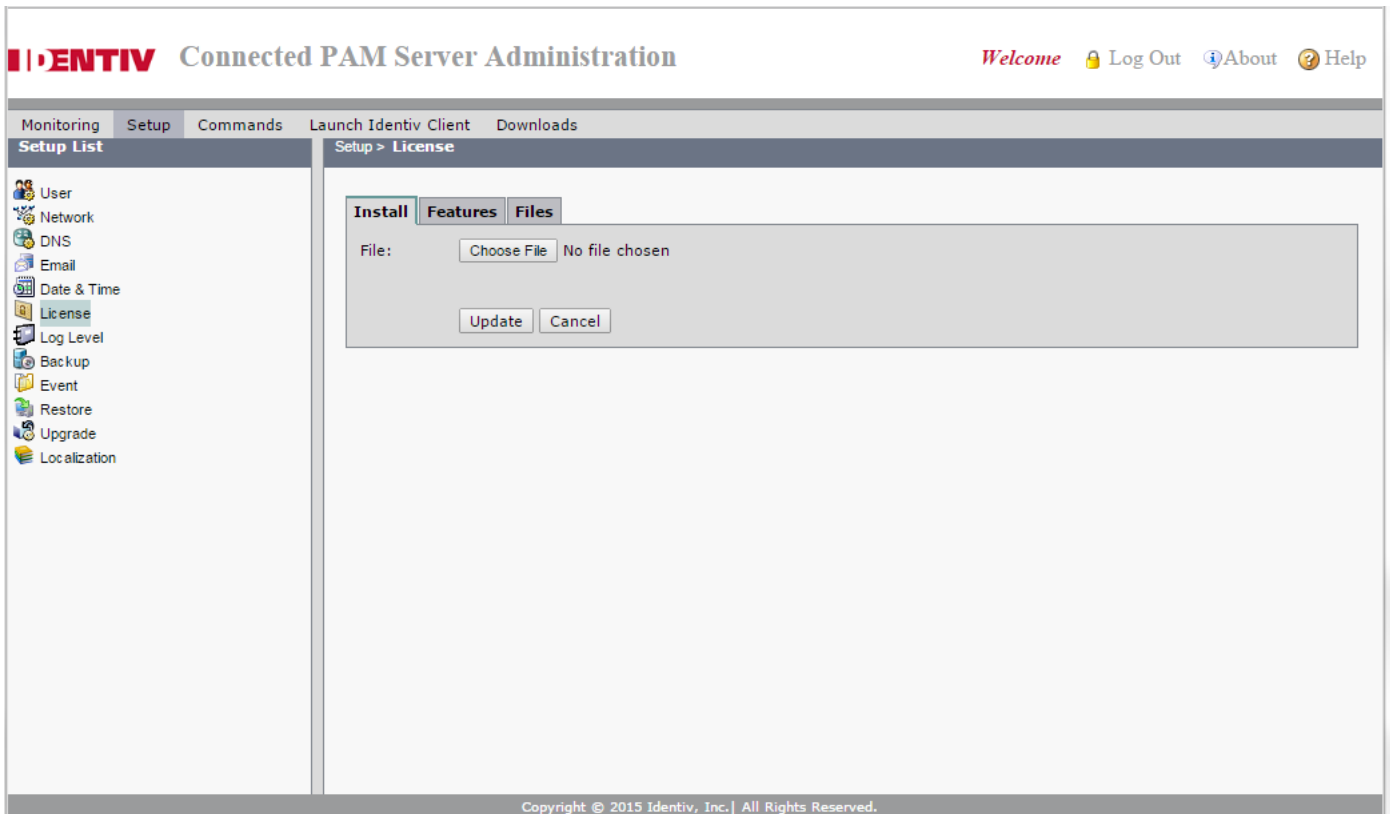

**Procedure:**

- 
- Step 1** Locate the Product Authorization Key (PAK) created with the purchase of the optional feature.
- Step 2** In a Web browser, open the Identiv Product License Registration Web page:  
<http://www.identiv.com/go/license/>
- Step 3** Follow the onscreen instructions to complete the form and enter the Product Authorization Key (PAK). When you are done, a license file with the extension `.lic` is sent to your email address.
- Step 4** Transfer the file to the drive of the PC used for the configuration.
- Step 5** In the License screen (Figure 2-30), click **Browse** to select the license file located on your local drive. When selected, the file name appears in the File field.
- Step 6** Select **Update** to install the license file on the ICPAM appliance and activate the features.
- Step 7** Select the **Features** tab to verify that the new license was added. See [Displaying a Summary of Installed Licenses](#), page 2-47 for more information.
- Step 8** Quit and relaunch the ICPAM desktop software to access the new feature menus.
- 

## Displaying a Summary of Installed Licenses

From the ICPAM Server Administration utility, select the **Features** tab in the Setup menu to view a list of installed feature licenses, as shown in Figure 2-31.

Figure 2-31 License Features List

The screenshot displays the ICPAM Server Administration web interface. The top navigation bar includes the Identiv logo, the title "Connected PAM Server Administration", and user options: "Welcome", "Log Out", "About", and "Help". Below the navigation bar, there are tabs for "Monitoring", "Setup", "Commands", "Launch Identiv Client", and "Downloads". The "Setup" tab is active, and the "License" sub-tab is selected. On the left side, a "Setup List" sidebar contains various configuration categories: User, Network, DNS, Email, Date & Time, License (highlighted), Log Level, Backup, Event, Restore, Upgrade, and Localization. The main content area shows the "License" configuration page with three tabs: "Install", "Features", and "Files". The "Features" tab is active, displaying a table with the following data:

Feature	Maximum Usage
Enterprise Integration	1

## Displaying the ICPAM Appliance Serial Number

To view the appliance serial number, do the following:

- Step 1** Log on to the ICPAM Server Administration utility:
- For a direct connection, see [Connecting a PC to the Appliance, page 2-5](#).
  - For an Internet connection, open a web browser and enter the IP address used for the ICPAM Server Administration utility. See [Logging on to the ICPAM Server Administration Utility, page 2-2](#), or ask your system administrator for assistance.



**Note** The administration screens also appear immediately following the initial setup.

- Step 2** Select the **Monitoring** tab, and then select **Status**.
- Step 3** Refer to the entry for *Serial Number*, as shown in [Figure 2-32](#).

**Figure 2-32** ICPAM Appliance Serial Number

The screenshot shows the ICPAM Server Administration web interface. The top navigation bar includes the Identiv logo, the title "Connected PAM Server Administration", and links for "Welcome", "Log Out", "About", and "Help". Below the navigation bar are tabs for "Monitoring", "Setup", "Commands", "Launch Identiv Client", and "Downloads". The "Monitoring" tab is selected, and the "Status" sub-tab is active. The main content area is divided into two sections: "Server" and "Services".

Server	
Admin State:	Up <input type="button" value="Stop"/>
Server Mode:	Active
Version:	2.0.0
Serial Number:	000C29200881
High Availability Audit:	disabled

Services	
TFTP Service	Up <input type="button" value="Stop"/>
Web Service API	Enabled <input type="button" value="Disable"/>

At the bottom right of the interface, there is a "Cisco Compatible" logo. The footer contains the text "Copyright © 2015 Identiv, Inc. | All Rights Reserved."

## Performing a Graceful Failover with Redundant Appliances

An automatic failover from the active appliance to the standby appliance occurs if the active appliance goes offline.

To trigger a graceful failover, stop the active appliance. Log on to the ICPAM Server Administration utility on the active appliance, and select **Stop Server**, **Reboot**, or **Shut Down**. See [Using the Web Admin Menus, Commands, and Options, page 2-19](#) for more information.

**Caution**

A system failover can result in a temporary loss of data. Log and other system messages sent from the access gateways and other hardware components may be dropped during the failover process. Identiv recommends performing a manual failover only when system usage is low.

## Troubleshooting and Monitoring

See [Using the Web Admin Menus, Commands, and Options, page 2-19](#) for information on the monitoring and troubleshooting features available in the ICPAM Server Administration utility. Most of the functions are used to gather information for Identiv technical support. For more information, contact your Identiv support representative.

**Caution**

Using the **Show Tech** command is processor intensive and can result in poor system performance while the information is gathered from your system. Use the **Show Tech** command under the direction of a Identiv technical support representative only.

For information on feature licenses, see [Licensing: Frequently Asked Questions, page E-1](#).

## Next Steps

After the initial setup is complete, the ICPAM appliance is ready to configure the access control features of your system, including doors, users, badges, and other features. See [Chapter 3, “Getting Started With the ICPAM Desktop Software”](#) for instructions about how to log in and get started. For information about installing and configuring the access gateway and other physical modules, see the *Cisco Physical Access Gateway User Guide*.

■ Next Steps

# Getting Started With the ICPAM Desktop Software

---

This chapter describes how to install the ICPAM desktop client software, log on to ICPAM, and manage its windows and dialogs. This chapter also includes an overview of the ICPAM user interface, and explains how to use the features provided by various toolbar buttons.



**Tip**

---

See [Installation and Configuration Summary, page 1-3](#) for an overview of installation and configuration tasks.

---

## Contents

- [Before You Begin, page 3-2](#)
- [Installing or Updating the ICPAM Desktop Software, page 3-2](#)
- [Logging into the ICPAM Client, page 3-3](#)
- [Understanding the Start Page and Window Management, page 3-4](#)
- [Keeping a Module On Top, page 3-6](#)
- [User Interface Elements, page 3-8](#)
- [Toolbar Features, page 3-10](#)
  - [Creating Reports, page 3-10](#)
  - [Using Filters, page 3-12](#)
  - [Revising the Column Display, page 3-14](#)
  - [Using Group Edit, page 3-14](#)
  - [Search, page 3-15](#)

## Before You Begin

Before you can use the ICPAM desktop software to configure the Identiv Connected Physical Access Manager, do the following:

- Verify that your computer is connected to the Internet, including access to the ICPAM appliance through the IP network.
- Verify that your PC meets the following requirements:
  - Windows XP or Vista with Internet Explorer 6.0 or higher, or Windows 7 (32-bit or 64-bit) with Internet Explorer 8.0 (32-bit only). To install and use the ICPAM client on 64-bit Windows, a 32-bit JRE needs to be installed.
  - Java Runtime Environment (JRE) 1.7 32-bit. To download Java, go to <http://www.oracle.com/technetwork/java/javase/downloads/jre7-downloads-1880261.html>
  - 2.8 GHz Intel Pentium IV processor or higher.
  - 2GB RAM or more.
  - 100 MB hard disk space available for the application, and an additional 20 GB or more disk space for logging.
- Obtain your username and password from your system administrator.

## Installing or Updating the ICPAM Desktop Software

To install the desktop software, you must connect to the ICPAM Server Administration utility.

Always upgrade the ICPAM desktop client when the server software is upgraded. If the versions are not the same, an error occurs when launching the desktop client.

- 
- Step 1** Log on to the ICPAM Server Administration utility:
- To use a direct connection, see [Connecting a PC to the Appliance, page 2-5](#).
  - To use an Internet connection, open a Web browser and enter the IP address used for the ICPAM Server Administration utility. See [Understanding IP Addresses on the ICPAM Server, page 2-3](#), or ask your system administrator for assistance.
- Step 2** Select **Launch ICPAM Client** from the Login window, as shown in [Figure 3-1 on page 3-3](#).
- If the correct version of the ICPAM desktop is already installed on your PC, the application launches.
  - If the client is not installed, or is out of date, the software is installed or updated on your PC. The Java runtime environment software is also installed or updated.
  - If the download fails, check your Java Web Start network settings. The ICPAM client launches using Java Web Start.



Figure 3-1 ICPAM Server Administration Utility: Login



Tip

For additional methods to install or upgrade the ICPAM desktop software using the ICPAM Server Administration utility, See [Using the Web Admin Menus, Commands, and Options, page 2-19](#).

## Logging into the ICPAM Client

Launch the ICPAM desktop client software to display the login prompt (Figure 3-2).

Figure 3-2 Log In dialog (with Language options)

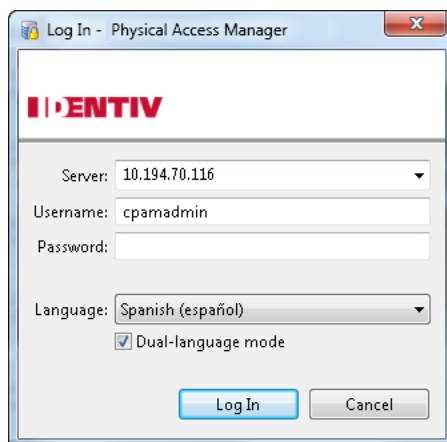

- Step 1** In the **Server** field, specify the IP address of the ICPAM appliance. You can click the triangle on the right side of the field to open a drop-down list that enables you to select a previous entry. (The system remembers the last five server addresses.)

- Step 2** Type your **Username** and **Password** (both are case-sensitive).
- Step 3** (Optional) If any optional language packs have been installed, you can choose an alternate language from the **Language** drop-down list.
- Step 4** (Optional) To display both the alternate language and English in the application, select the **Dual-language mode** option.

For more information about language packs, see the “[Installing and Revising Language Packs](#)” section on page 2-30.

- Step 5** Click **Log In**.

If the username and password are valid, ICPAM displays the **Start Page**, or the modules that were open during the operator’s previous session.



**Tip**

To change your password, log on to the ICPAM appliance and select **Change Password** from the **Options** menu.

## Understanding the Start Page and Window Management

The Start Page is opened by default when you open the ICPAM desktop client for the first time, as shown in [Figure 3-3](#). The main drop-down menu bar provides access to ICPAM features, and is also displayed in the main window for each module.

*Figure 3-3 ICPAM Client’s Start Page*

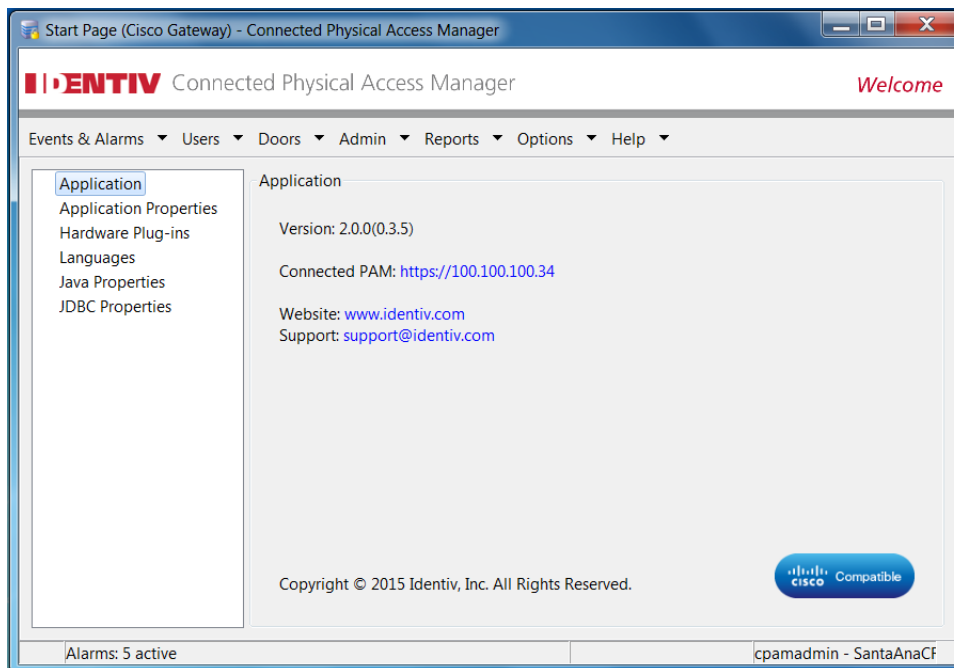

**Note**

The available modules vary depending on the software license purchased and the operator's access privileges. Some menus are activated only after the feature license is installed. See [Obtaining and Installing Optional Feature Licenses, page 2-45](#) and [Chapter 4, "Configuring User Access for the ICPAM Desktop Client"](#).

Select a menu item to open the main window for that module in a new window, as shown in [Figure 3-4](#). You can open multiple module windows simultaneously and drag the windows across multiple monitors. The size and position of the open windows is restored when you log out and log back in.

**Figure 3-4**      *Device Templates Window*

Name	Description	Model	Vendor
10 Wire Wiegand	Standard 10 Wire Wiegand Reader	Reader 201	Acme Inc.
10 Wire Wiegand Buffered KP	Standard 10 Wire Wiegand Reader Template with buffered Keypad	Reader 201	Acme Inc.
10 Wire Wiegand Unbuffered KP	Standard 10 Wire Wiegand Reader Template with unbuffered Keypad	Reader 201	Acme Inc.
5 Wire Wiegand	Standard 5 Wire Wiegand Reader	Reader 101	Acme Inc.
ADA 5 Wire Wiegand	Standard 5 Wire Wiegand Reader	Reader 101	Acme Inc.
Deadbolt Template	Deadbolt Template	Deadbolt101	Acme Inc.
Door Sensor (NC)	Door Sensor	DoorSensor101	Acme Inc.
Door Sensor (NO)	Door Sensor	DoorSensor102	Acme Inc.
Door Swing Template	Door Swing Template	DoorSwing101	Acme Inc.
Duress Sensor (NC)	Duress Sensor	DuressSensor	Acme Inc.
Duress Sensor (NO)	Duress Sensor	GenericDuressSensor	Acme Inc.
Fire Sensor (NC)	Fire Sensor	FireSensor	Acme Inc.
Fire Sensor (NO)	Fire Sensor	GenericFireSensor	Acme Inc.
Generic Input (NC)		GenericInput101	Acme Inc.
Generic Input (NO)		GenericInput102	Acme Inc.
Generic Output Template		GenOut101	Acme Inc.
GlassBreak Sensor (NC)	GlassBreak Sensor	GlassBreak	Acme Inc.
GlassBreak Sensor (NO)	GlassBreak Sensor	GenericGlassBreak	Acme Inc.
Lock Template	Lock Template	Lock101	Acme Inc.

Alarms: 5 active      26 items      cpamadmin - SantaAnaCR

## Keeping a Module On Top

You can configure an ICPAM module to be always displayed on top. When ICPAM is open, the selected module always remains on top of other ICPAM windows, or any other applications.

To configure a window to always be on top:

- Step 1** Select **Always on Top** from the Options menu, as shown in [Figure 3-5](#).

*Figure 3-5 Always on Top*

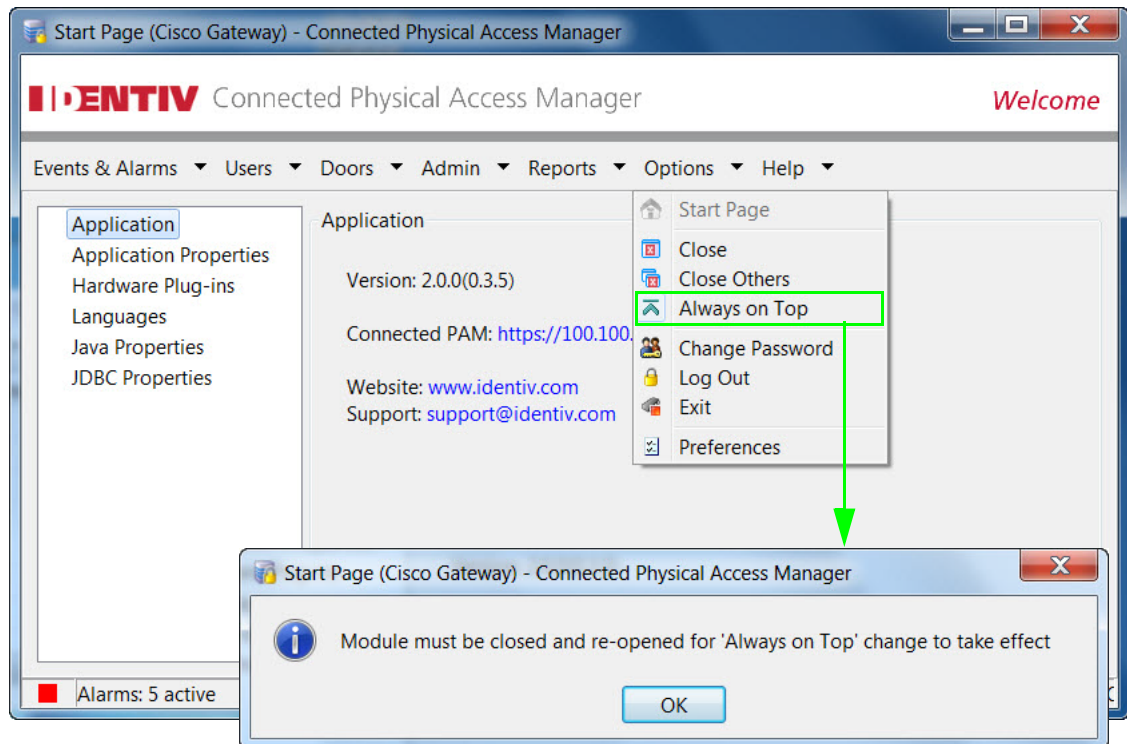

- Step 2** Click **OK** to close the confirmation message.
- Step 3** Close the module's window and reopen it for changes to take effect.



**Tip**

Before closing the window, be sure another ICPAM module is open or the application will quit.



**Note**

When selected, **Always on Top** is displayed with a check. The setting remains in effect even if you close and then reopen the window.

## Choosing Multiple *Always on Top* Windows

You can select more than one window to be on top. The windows remain on top of all other windows, except each other. Click an *Always on Top* window to bring it to the front.

When you select additional *Always on Top* windows, you must click **OK** in the confirmation dialog shown in [Figure 3-6](#), and then close and reopen the module's window.



Note

If the confirmation message is hidden behind an existing Window on Top, rearrange the windows so you can clear the message.

*Figure 3-6 Always on Top Confirmation Message*

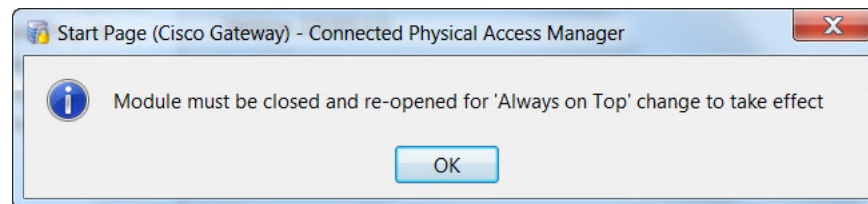

## Deselecting *Always on Top*

To deselect the **Always on Top** option, do the following:

- Step 1** Choose the **Options > Always on Top** command again to remove the check mark.
- Step 2** Click **OK** to close the confirmation message (shown in [Figure 3-6](#)). If the confirmation message is hidden behind an existing window that is on top, rearrange the windows so you can clear the message.
- Step 3** Close the module's window and reopen it for changes to take effect.
- Step 4** Repeat the previous steps to deactivate the **Always on Top** option for additional windows.

# User Interface Elements

The user interface for most features includes the following elements (from top to bottom):

**Figure 3-7** User Interface Elements

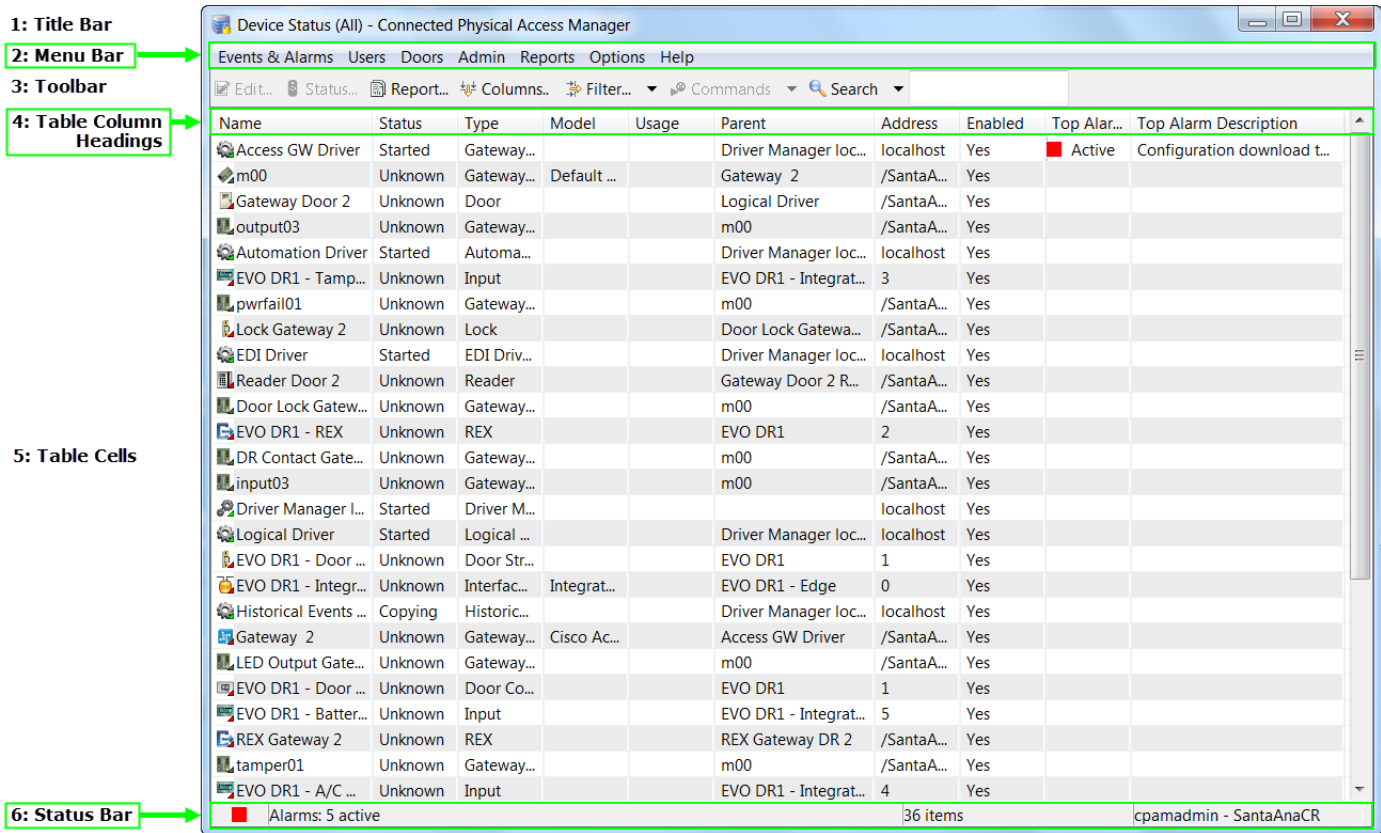

The user interface elements called out in [Figure 3-7](#) are described in the following table.

**Table 3-1** Typical User Interface Elements

#	UI Element	Description
1	Window Title Bar	Shows the module and application name. For example: Device Status (All).
2	Menu Bar	Enables the operator to perform a number of functions, including open a new module, close a module or the application, and get help. This menu bar is the same for all modules.

Table 3-1 Typical User Interface Elements (continued)

#	UI Element	Description
3	Toolbar	<p>Contains a set of buttons that are specific to the module being used. Typical buttons include:</p> <ul style="list-style-type: none"> <li>• <b>Scroll Lock:</b> Disable or enable automatic scrolling of the list as new items are inserted.</li> <li>• <b>View... or Edit...:</b> View or edit the selected item's properties in a detail window.</li> <li>• <b>Add...:</b> Add a new item.</li> <li>• <b>Disable or Delete:</b> Disable or delete the selected item.</li> <li>• <b>Report...:</b> Display the available data as a report, which may be printed or saved as a PDF file. See <a href="#">Creating Reports, page 3-10</a>.</li> <li>• <b>Filter:</b> Select or edit a filter. that determines which items are visible in the table. See <a href="#">Using Filters, page 3-12</a>.</li> <li>• <b>Columns...:</b> Configure which columns are visible, and the order in which they appear. See <a href="#">Revising the Column Display, page 3-14</a>.</li> <li>• <b>Group Edit:</b> Make changes to all items displayed in a module's table. See <a href="#">Using Group Edit, page 3-14</a>.</li> <li>• <b>Quick Search:</b> Quickly search results in the main module window. See <a href="#">Search, page 3-15</a>.</li> </ul>
4	Table Column Headings	<p>Column visibility and order may be edited using the <b>Columns...</b> button in the toolbar. Column width may be adjusted by dragging the edge of the column header. Clicking a column header allows the list to be sorted by a particular column. A directional arrow shows the current sort column, as well as the direction of the sort order. Clicking the column header a second time reverses the sort order. See <a href="#">Revising the Column Display, page 3-14</a>.</p>
5	Table Cells	<p>The table cells show the information about the items, with one row per item. Selecting an item within the table enables the use of certain buttons, and right-clicking on an item displays a pop-up menu of the actions that can be performed on the item. (Each module will have a different table.)</p>
6	Status Bar	<p>Appears at the bottom of each module window. It is divided into 4 panes:</p> <ul style="list-style-type: none"> <li>• <i>Pane 1:</i> If there are any uncleared alarms, this pane displays a colored and or blinking icon showing the alarm status. This pane is not pictured in the above figure.</li> <li>• <i>Pane 2:</i> If there are any uncleared alarms, this pane displays text describing the number of alarms, as well as their state. This pane is not pictured in the above figure.</li> <li>• <i>Pane 3:</i> Shows the number of items in the table.</li> <li>• <i>Pane 4:</i> Displays the username of the logged-in operator, as well as the IP address or hostname they are logged in from.</li> </ul>

# Toolbar Features

The toolbar includes a common set of features used to sort and revise information and records. This section includes the following topics:

- [Creating Reports, page 3-10](#)
- [Using Filters, page 3-12](#)
- [Revising the Column Display, page 3-14](#)
- [Using Group Edit, page 3-14](#)
- [Search, page 3-15](#)

## Creating Reports

Many ICPAM modules include a Report feature. The following example describes how to create an Events report.

- Step 1** Open the desired module (in this example the **Events** module) by selecting it from the **Start Page** or from the Module menu.
- Step 2** Click the **Report...** button in the toolbar. This opens the **Report Generation** dialog ([Figure 3-8](#)).

**Figure 3-8** Report Generation dialog

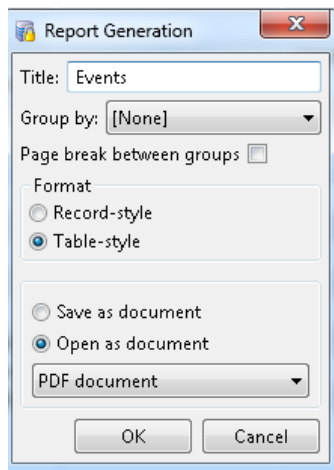

The fields and options that can appear on this dialog are described in the following table.

**Table 3-2** Report Generation

Field or Option	Description
<b>Title</b>	The title of the report.
<b>Include</b>	Depending on the type of objects in the report (event, badge, personnel record, and so on), there may be additional details that can be included in the report. If so, these will be available as check box options. For example, in a report of personnel records, checking the <b>Badges</b> option will include a list of the badges assigned to each person.



Table 3-2 Report Generation (continued)

Field or Option	Description
<b>Group by</b>	If this option is set to something other than <b>[None]</b> , the items in the report will be grouped by the specified property, with a header for each group.
<b>Page break between groups</b>	If the <b>Group by</b> option is set to something other than <b>[None]</b> , you can select the option to force a page break between each group.
<b>Format</b>	<ul style="list-style-type: none"> <li>• <b>Record-style:</b> displays the data similarly to the layout of an address book, and in a portrait (vertical) view.</li> <li>• <b>Table-style:</b> displays the data in a grid layout, similar to a spreadsheet, and in a landscape (horizontal) view.</li> </ul>
<b>Viewing Options</b>	<ul style="list-style-type: none"> <li>• <b>Open in report:</b> Opens the report with an integrated report.</li> <li>• <b>Save as document:</b> Saves the report as either a PDF document, an Excel spreadsheet, OpenDocument text, Text (tab-delimited), HTML, or an OpenDocument spreadsheet.</li> <li>• <b>Open as document:</b> Allows you to open the report in a number of formats, including a PDF document, an Excel spreadsheet, OpenDocument text, Text (tab-delimited), HTML, or an OpenDocument spreadsheet.</li> </ul>

**Step 3** Choose the desired options, and then click **OK** to save or open the report. This may take a moment, depending on the size and complexity of the report. [Figure 3-9](#) shows a report in PDF format from the **Events** module.

Figure 3-9 Example of an Events Report

Events	
Time	8/24/2015 10:26:42
Description	Operator logged out
Device	CPAM-PC
Personnel Record	
Credential	cpamadmin
Data	
Time	8/24/2015 10:26:42
Description	Workstation: Logged Out
Device	CPAM-PC
Personnel Record	
Credential	
Data	
Time	8/21/2015 13:31:50
Description	HID Controller command: Download Configuration
Device	MaryJo-Opti9020
Personnel Record	

## Using Filters

Many ICPAM modules include a **Filter** button that provides the following options:

- **No Filter**: Show all items, without filtering.
- **Default Filter**: The default view of the table. Shows all enabled items.
- **Presets**: Select from preset filters. A check mark next to a filter indicates which filter is currently in use, as shown in [Figure 3-11](#).
- **Preset Manager...**: Manage the presets.
- **Edit Filter...**: View or edit the current filter.
- **Max rows...**: Specify the maximum number of items (rows) to be displayed. Some items, such as events, often exist in such large quantities that viewing them all simultaneously is impractical.

When editing or viewing a filter, the operator may select or enter the various criteria to filter by. In addition, the following actions are available:

- **View Query...**: View the filter as a SQL-like expression. This feature is intended for advanced operators.
- **Save as Preset...**: Save the current filter as a preset, which can be quickly accessed from the **Filter** button.
- **Reset**: Reset the filter to the default.
- **OK**: Apply the changes to the filter and close.
- **Cancel**: Cancel any changes to the filter and close.

### Filter Creation Example

To create a filter in the **Events** module, do the following:

- 
- Step 1** Choose the **Events & Alarms > Monitoring > Events** command.
  - Step 2** Click **Filter** in the toolbar to open the filter window, as shown in [Figure 3-10](#).

Figure 3-10 Filter - Event Window

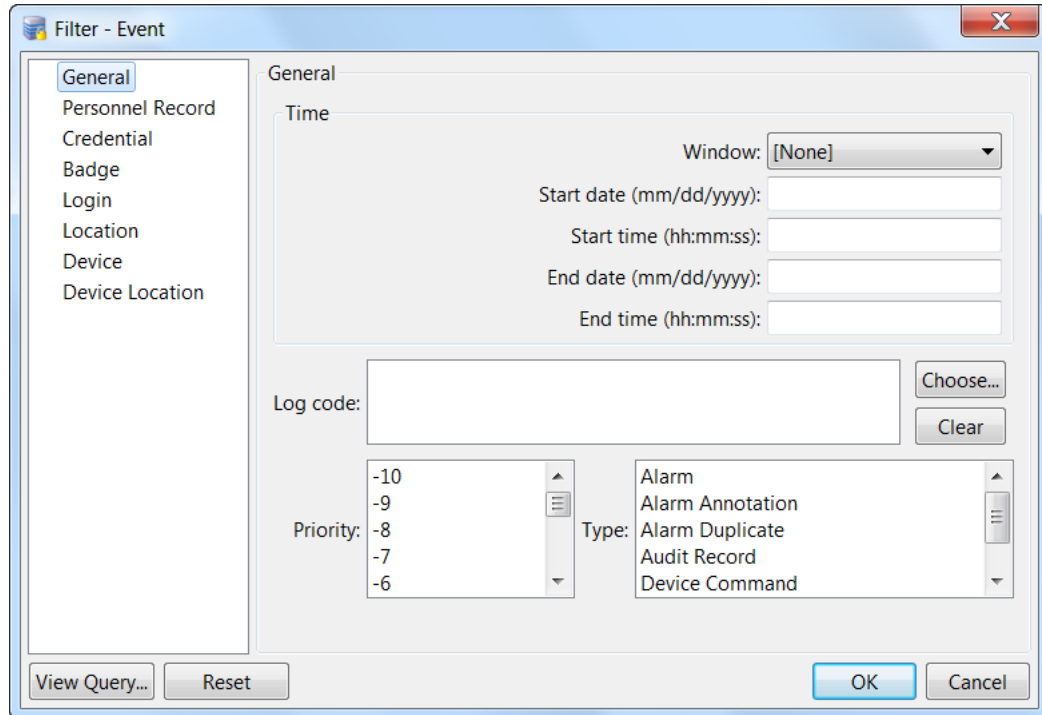

**Step 3** Specify the object filtering criteria.

- The **General**, **Personnel Record**, **Credential**, **Badge**, **Login**, and **Device** tabs on the left specify the event criteria, such as the event's properties or associated objects.
- The **View Query...** button opens a window detailing the actual filter definition as a SQL-like expression string.
- The **Save as Preset...** button saves the filter criteria as a named preset for later use. After a filter has been saved as a preset, it can be selected from the **Filter** button's drop-down menu, as shown in [Figure 3-11](#).
- The **Reset** button clears the filter so that all enabled items will be displayed.

Figure 3-11 Filter Presets

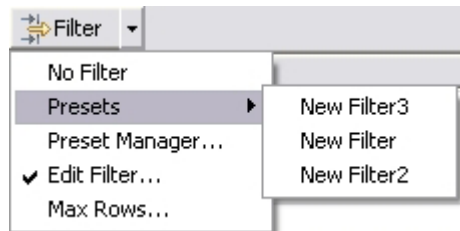

**Step 4** Choose the criteria to filter by, then click the **OK** button. This closes the window, and the table view is updated to reflect the filter criteria. Incoming events will also be filtered according to these criteria.

## Revising the Column Display

The **Columns...** button in the toolbar enables you to change the order and visibility of columns.

Click the **Columns...** button to open the dialog shown in [Figure 3-12](#).

- Select or deselect the check boxes next to the column names to determine which columns are visible in the table view.
- Select a column name and click the **Up** or **Down** buttons to change the order in which the columns appear.
- Click **OK** to save your changes and view them in the module.

*Figure 3-12 Columns dialog for the Event Manager*

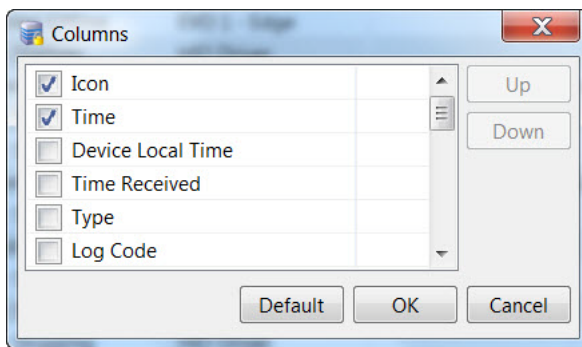

**Tip**

Adjust column width by dragging the edge of the column header. Click on a column header to sort the table by that particular column. A directional arrow shows the currently sorted column, as well as its direction. Reverse the sort order by clicking on the column header again.

## Using Group Edit

The **Group Edit** button enables you to make changes to all items in a list, or multiple selected items. **Group Edit...** is included in the **Badges** and **Personnel** modules.



**Tip**

To limit the items in the list, filter the content as described in [Using Filters, page 3-12](#) before using group edit.

Right-click the **Group Edit** button in the **Badges** and **Personnel** and select **Group Edit All Items** or **Group Edit Selected Items**.

## Group Edit Example

In the following example, a group edit is used to change all contractor badges to be inactive.

- Step 1** Choose the **Users > Badges** command.
- Step 2** Filter the list so it contains only the records to be changed.
  - a.** Click the **Filter** button in the toolbar.

- b. Select the **Assigned to** tab.
- c. Select **Contractor** in the **Personnel type** field.
- d. Click **OK** to filter the badges to contractor personnel types.

See [Using Filters](#), page 3-12 for more information.

- Step 3** In the Badges window, click the **Group Edit...** button to open the **Group Edit...** window, as shown in [Figure 3-13](#).

*Figure 3-13 Group Edit - General page*

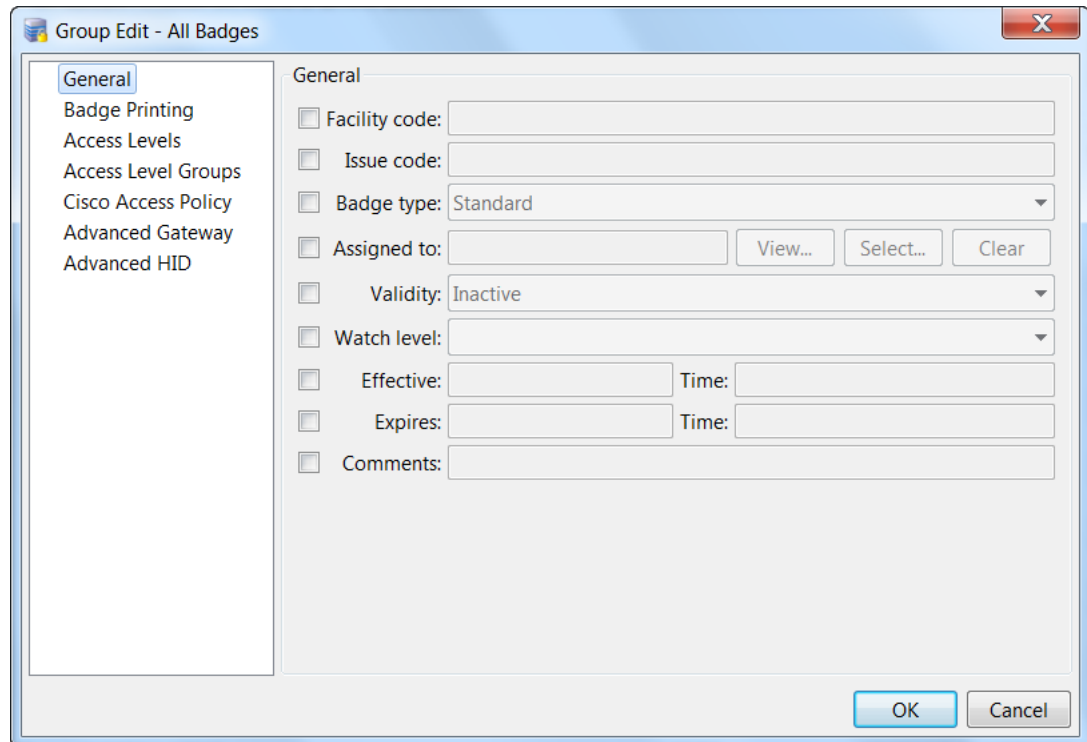

- Step 4** Select the **Validity** check box, and then select **Inactive** from the drop-down menu.

- Step 5** Click **OK**.

All Contractor badges in the filtered list are now changed to **Inactive**.

## Search

**Search** enables operators to quickly search results in a module's main window. Type some text in a search field, and then either click the **Search** button or press the **Enter** key. To remove the search, clear the field and then click the **Search** button.

You can click the drop-down arrow on the right side of the **Search** button to select the different methods of quick search. Options include:

- **Quick search with filter:** Search within the results of the current **Filter** set.
- **Quick search instead of filter:** Search without regard to any filter that is currently defined.



# Configuring User Access for the ICPAM Desktop Client

This chapter describes how to configure operators for the ICPAM desktop client.



Note

Whenever you upgrade the server software, you must also upgrade the desktop software. If the versions are not the same, an error will occur when launching the desktop client. See [Installing or Updating the ICPAM Desktop Software, page 3-2](#).

## Contents

- [Defining User Profiles for Desktop Application Access, page 4-1](#)
- [Creating User Login Accounts and Assigning Profiles, page 4-9](#)
- [Configuring LDAP User Authentication, page 4-14](#)
- [Viewing Audit Records for Changes to Usernames, page 4-19](#)
- [Managing Desktop Client Passwords, page 4-21](#)

## Defining User Profiles for Desktop Application Access

Profiles are pre-defined sets of access privileges that define the ICPAM modules and commands available to a user. For example, users that should have all privileges can be assigned to the Administrators profile.

If the profile enhancement feature is set in the system configuration settings (for more information, see [Logins page of the System Configuration window, page 17-11](#)), the following changes occur in this module:

- While creating user profiles, the application prompts the user to select hierarchical location for a specific user profile.
- When the profile enhancement feature is set, the administrator profile cannot be reused even by the cpadmin, i.e the cpadmin cannot assign the administrator profile to any profile users.
- Assigning a location to a profile in the **Hierarchical location** field specifies the location of the profile. Other than the cpadmin this specific profile can be accessed only by the users belonging to this location.

**Note**

You cannot modify the Administrators profile (which is read-only).

To create profiles, do the following:

**Step 1** Choose the **Users > Profiles** command.

*Figure 4-1 Profiles module main window*

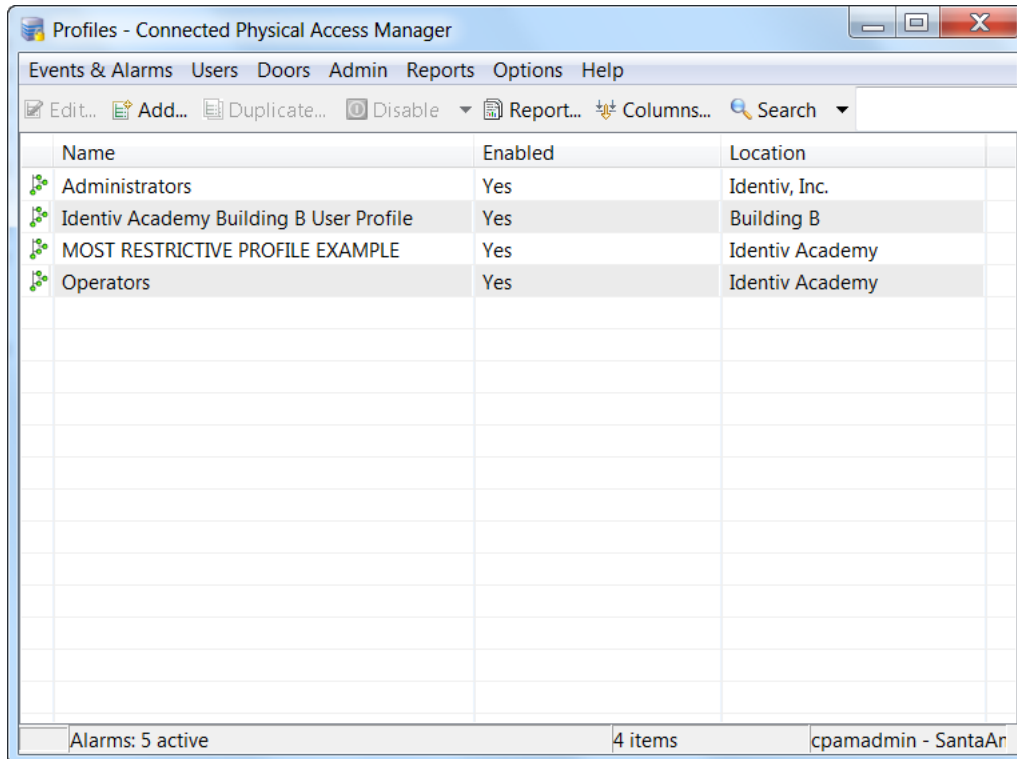

**Step 2** To add a profile, click the **Add...** button.

**Step 3** From the **Template** drop-down list on the resulting dialog, select the profile template that most closely matches the desired level of user access for your new profile.

- **Default:** A basic set of privileges is set.
- **Most Restrictive:** No privileges are set.
- **Least Restrictive:** All privileges are set.

*Figure 4-2 Profile Templates*

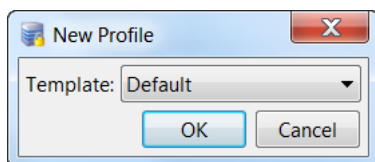

**Step 4** Click **OK** to open the **Add Profile** dialog.



Figure 4-3 Add Profile dialog - General tab

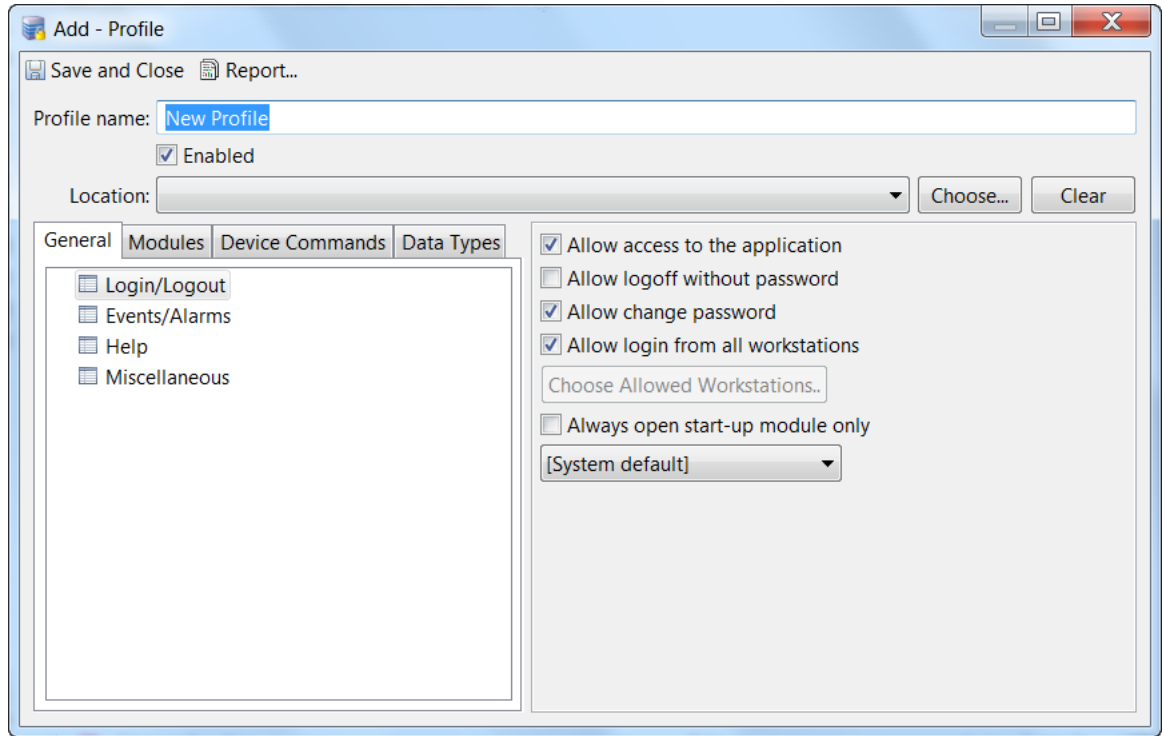

**Step 5** Enter the basic profile settings:

- Type the **Profile name**
- Select the **Enabled** option
- Specify the **Location**

**Step 6** Click on the **General** tab to define the basic profile properties. Click the check box in front of an option to enable or disable a specific privilege, as described in [Table 4-1](#).

Be sure to click on each of the option group items (**Login/Logout**, **Events/Alarms**, **Help**, and **Miscellaneous**) in the left pane, below the tab labels.

**Table 4-1** Add Profile dialog - General tab options

<i>Option</i>	<i>Description</i>
<b>Login/Logout</b>	
<i>Allow access to the application</i>	Allows users to access the ICPAM Client.
<i>Allow logoff without password</i>	Allows users to log off without entering the password.
<i>Allow change password</i>	Allows users to change the password.
<i>Allow login from all workstations</i>	Allows users to log in to the ICPAM Client from any workstation.
<i>Always open start-up module only</i>	

Table 4-1 Add Profile dialog - General tab options (continued)

<i>Option</i>	<i>Description</i>
<b>Events/Alarms: Alarm Annotations (Ack., Clear, Comment)</b>	
<i>Allow annotations</i>	Allows users to acknowledge, clear, and comment alarms. Click the <b>Filter</b> button to define the events that trigger the action.
<i>Allow multiple annotations</i>	Allows users to acknowledge, clear, and comment multiple alarms at one time.
<i>Allow clearing of unacknowledged alarms</i>	Allows users to clear unacknowledged alarms from the active devices.
<i>Allow clearing of active device alarms</i>	Allows users to clear alarms from active devices.
<i>Require comment on clearing alarms</i>	Allows users to clear the alarms that are not required anymore.
<b>Events/Alarms: On new alarms</b>	
<i>Open Alarms Module</i>	Automatically opens with new system alarms. Click the <b>Filter</b> button to define the events that trigger the action.
<i>Open Manage Alarm window</i>	Opens automatically to acknowledge/comment/clear the alarms. Click the <b>Filter</b> button to define the events that trigger the action.
<i>Open map</i>	Automatically opens with new system alarms. Click the <b>Filter</b> button to define the events that trigger the action.
<i>Show recorded video</i>	Displays recorded video with new system alarms. Click the <b>Filter</b> button to define the events that trigger the action.
<i>Show live video</i>	Displays live video with new system alarms. Click the <b>Filter</b> button to define the events that trigger the action.
<i>Show camera grid</i>	Allows the user to view the video stream in a grid format.
<b>Help:</b> defines access to the different help systems.	
<i>Allow access to help documentation</i>	Allows users to access help documentation.
<i>Enable context menu in help browser</i>	Allows users to view the help context menu.
<i>Allow access to help PDF</i>	Allows users to access the help PDF. (To access the help PDF, Adobe Acrobat is required.)

Table 4-1 Add Profile dialog - General tab options (continued)

Option	Description
<b>Miscellaneous</b>	
Allow issuing device command as default	Allows users to issue device commands directly to hardware.
Allow access to external hyperlinks	Allows users to access external hyperlinks.
Require device commands to be commented	Requires users to enter a comment with each device command issued in the system.
Allow editing from right-click menus	Allows users to access the right-click Edit menu.
Allow edit preferences	Allows users to edit preferences.
Rich client: Open modules in new window	Allows users to open modules in a new window.

- Step 7** Click on the **Modules** tab to specify which modules will be accessible to this profile, as shown in [Figure 4-4](#).

Figure 4-4 Add Profile dialog - Modules tab

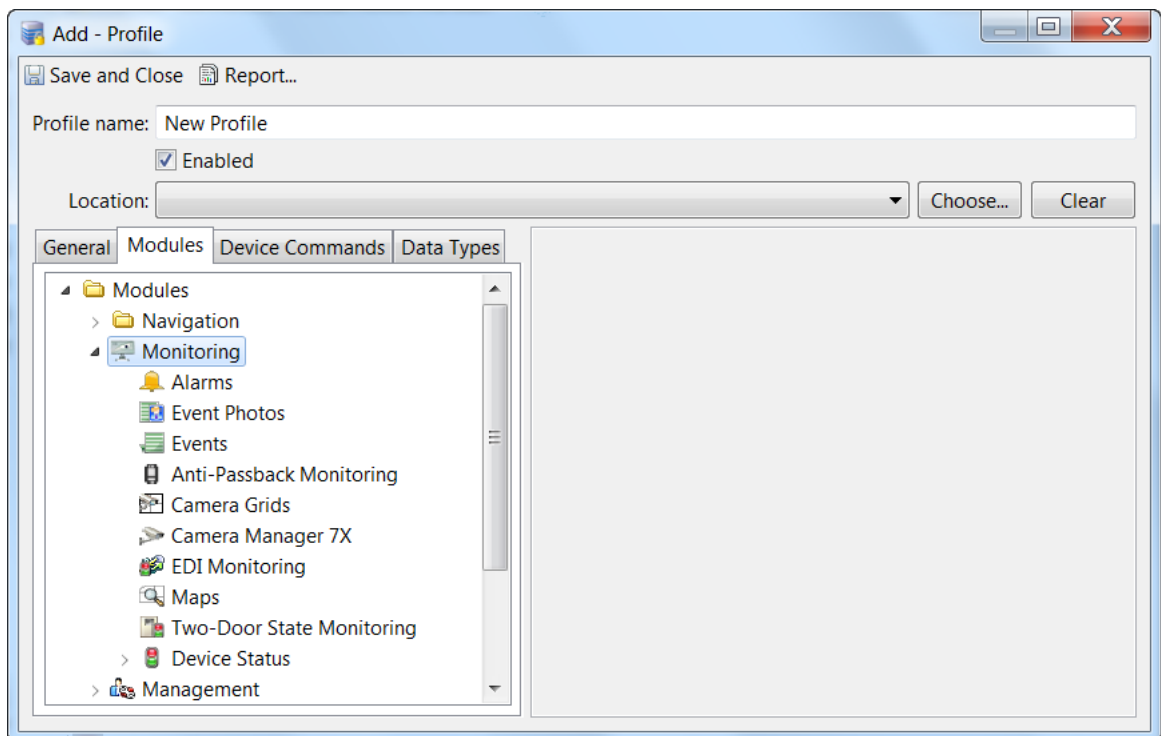

- a. Expand the tree in the left pane, and select an ICPAM module.

- b. Select **Allow access to module** to enable access to the module.
- c. (Optional) Use the **Default Filter** with modules such as Event, Badge, and Personnel to define the filter applied when a user opens the module.

### Example

To create a profile with access to the Events module that displays events for a specific door by default, complete the following steps:

- Create a profile with access to the Events module (as described in the previous steps).
- Click **Default Filter**.
- Select the **Device** tab.
- Click **Choose**.
- In the **Choose Devices** dialog, expand the physical driver device tree and select a door.

Figure 4-5 Choose Devices dialog

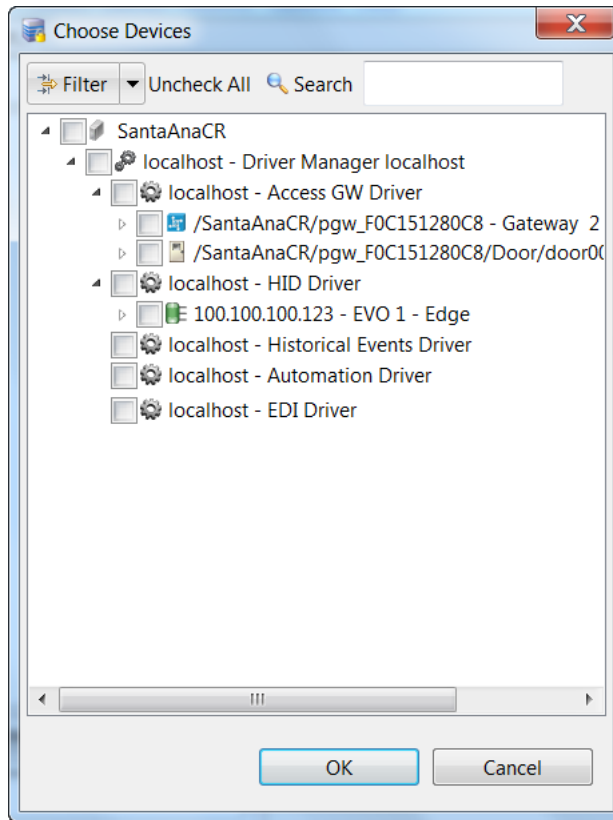

- Click **OK** to save the changes and close this dialog.

- Step 8** Click the **Device Commands** tab to define the hardware configuration commands available to the user (see [Figure 4-6](#)).

*Figure 4-6 Add Profile dialog - Device Commands tab*

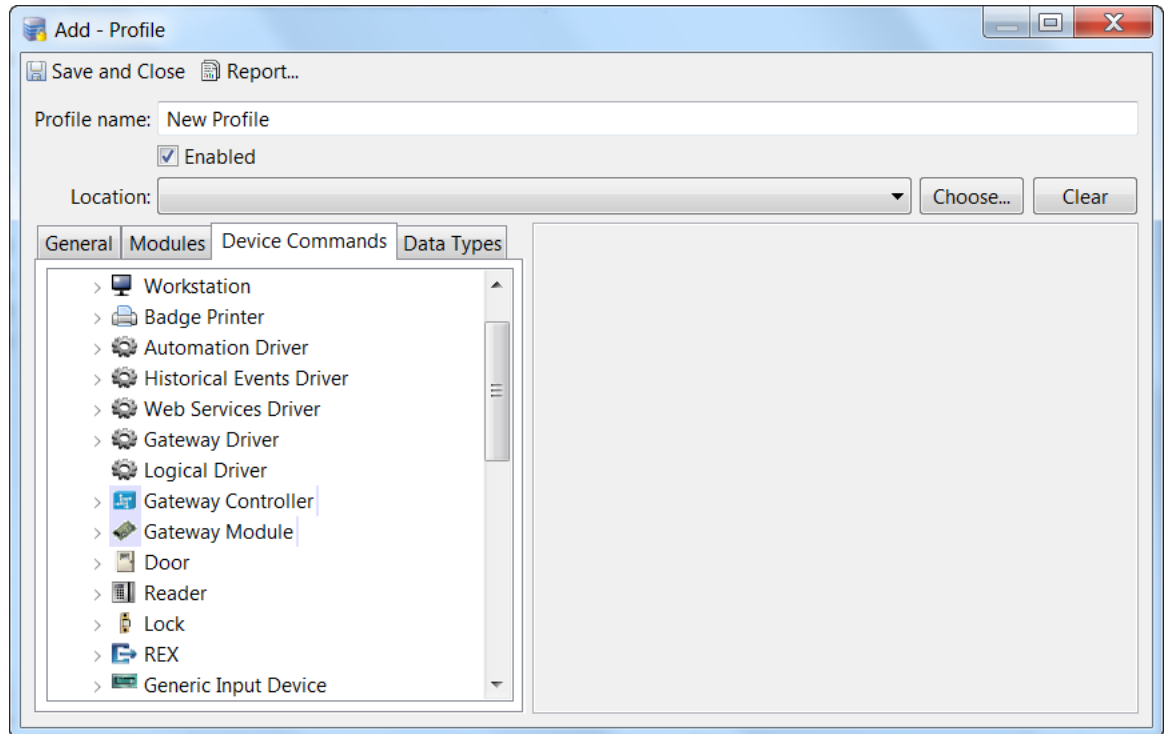

- a. In the left pane, expand or collapse the list of commands for a type of device.
- b. Click on a command to select it.
- c. Select the following options:
  - **Allow Command to be issued:**
    - **Default:** If this user profile has the privilege to issue device commands (determined by the *Allow issuing device command as default* option in the General tab's Miscellaneous group), access to the selected command is enabled by default.
    - **No:** Deny access to the selected command.
    - **Yes:** Allow access to the selected command.
  - **Filter:** Apply a filter to limit the devices for the command.

**Step 9** Click the **Data Types** tab to define the data available to this profile.

*Figure 4-7 Add Profile dialog - Data Types tab*

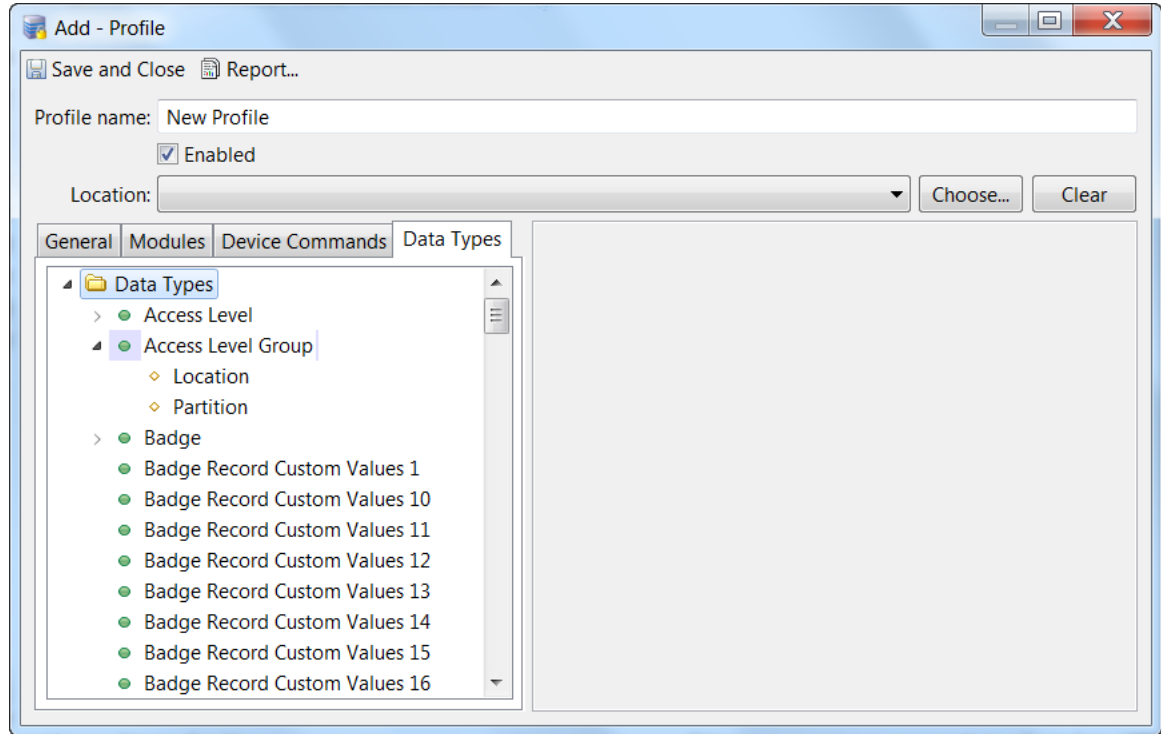

- a. In the left pane, expand or collapse the list, and select a specific type of data.
- b. To restrict the profile's access to that data, select the appropriate set of check boxes for the following options:

*Table 4-2 Add Profile dialog - Data Types tab options*

Option	Description
<i>View</i>	Allows the user to view the selected data type.
<i>Create</i>	Allows the user to add and create the selected data type.
<i>Modify</i>	Allows the user to modify existing data of this type.
<i>Delete</i>	Allows the user to delete data of this type.

**Step 10** Click the **Save and Close** button to save the profile settings.

**Step 11** Assign the profile to one or more ICPAM operators using the **Logins** module, as explained in the [“Creating User Login Accounts and Assigning Profiles” procedure on page 4-9](#).

# Creating User Login Accounts and Assigning Profiles

To give users access to ICPAM functionality, create a login account and assign one or more access profiles to the username.

**Step 1** Choose the **Users > Logins** command.

The resulting **Logins** main window (Figure 4-8) lists all the usernames in the system.

*Figure 4-8 Logins module main window*

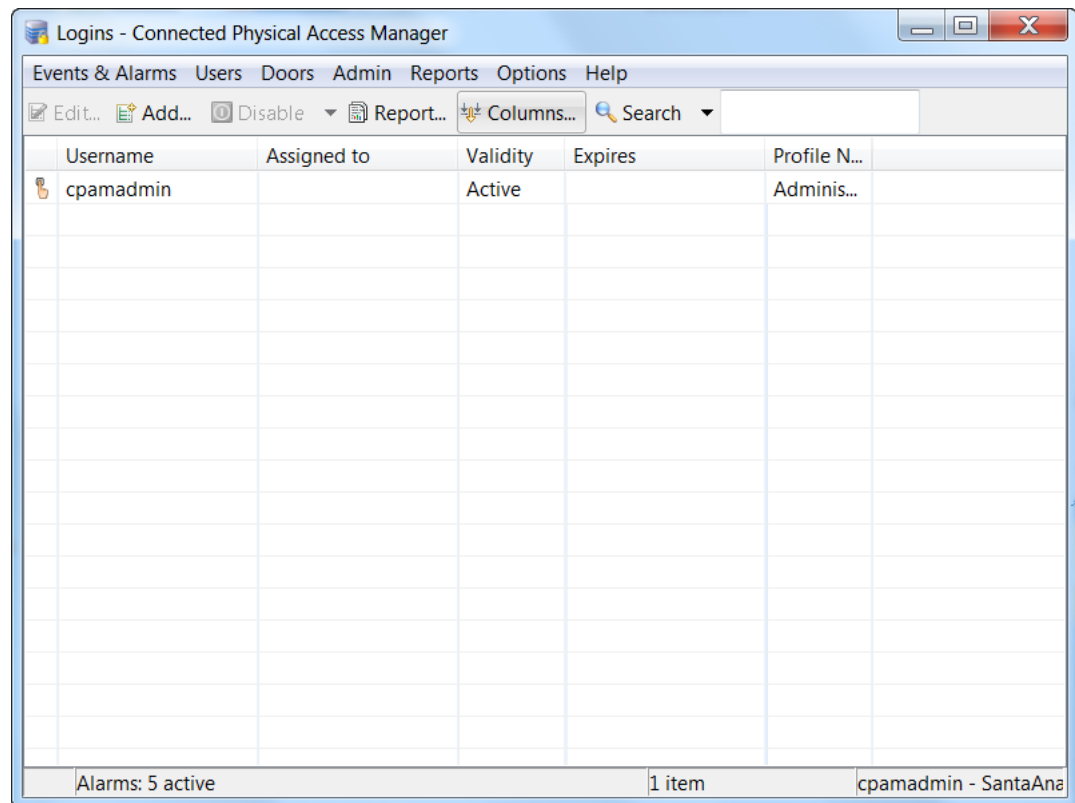

**Step 2** Click the toolbar button corresponding to the task you want to perform:

- To add a new login, click the **Add...** button.
- To modify an existing login, select its entry in the table, and then click the **Edit...** button.
- To remove an existing login, select its entry in the table, and then click the **Delete** button.

The remainder of this procedure demonstrates how to add a new login.



**Note**

You cannot modify most of the properties of the **cpamadmin** login.

**Step 3** On the **General** page, define the basic properties. [Table 4-3](#) describes the fields on this page.

**Figure 4-9** Add Login dialog - General page



**Note** The **Username**, **Password**, and **Confirm password** fields are required.

**Table 4-3** Add Login dialog - General page fields and options

Field or Option	Description
<b>Username</b>	(Required.) The username of this login.
<b>Password</b>	(Required.) The password for this login to access the system.
<b>Confirm password</b>	(Required.) Type the password again. The value must be entered exactly as it was in the <b>Password</b> field.
<b>Service login only</b>	
<b>Location</b>	This field specifies the login location of a user. Each login location can be accessed only by users belonging to that specific location.
<b>Assigned to</b>	The personnel record the login is assigned to.  If the login is for an operator already entered in the <b>Personnel</b> module, click the <b>Select...</b> button. For more information on adding personnel to the system, see <a href="#">Chapter 9, “Configuring Personnel and Badges”</a> .
<b>Validity</b>	From this drop-down list, choose either <b>Active</b> or <b>Inactive</b> . Only active accounts can access the system.



Table 4-3 Add Login dialog - General page fields and options (continued)

Field or Option	Description
<b>Effective</b>	The beginning date that the user can log in. If this field is left blank, the user can log in immediately.
<b>(Effective) Time</b>	The time on the Effective date when the user can log in.
<b>Expires</b>	The date that the login expires and access attempts will be denied. If this field is left blank, access is allowed indefinitely.
<b>(Expires) Time</b>	The time on the Expires date when the user login expires.
<b>Comments</b>	Optional descriptive comments or notes about the login.

**Step 4** To create a new location-restricted user profile, perform these steps.

- a. Click on the **Profiles** item in the left pane.

Figure 4-10 Add Login dialog - Profiles page

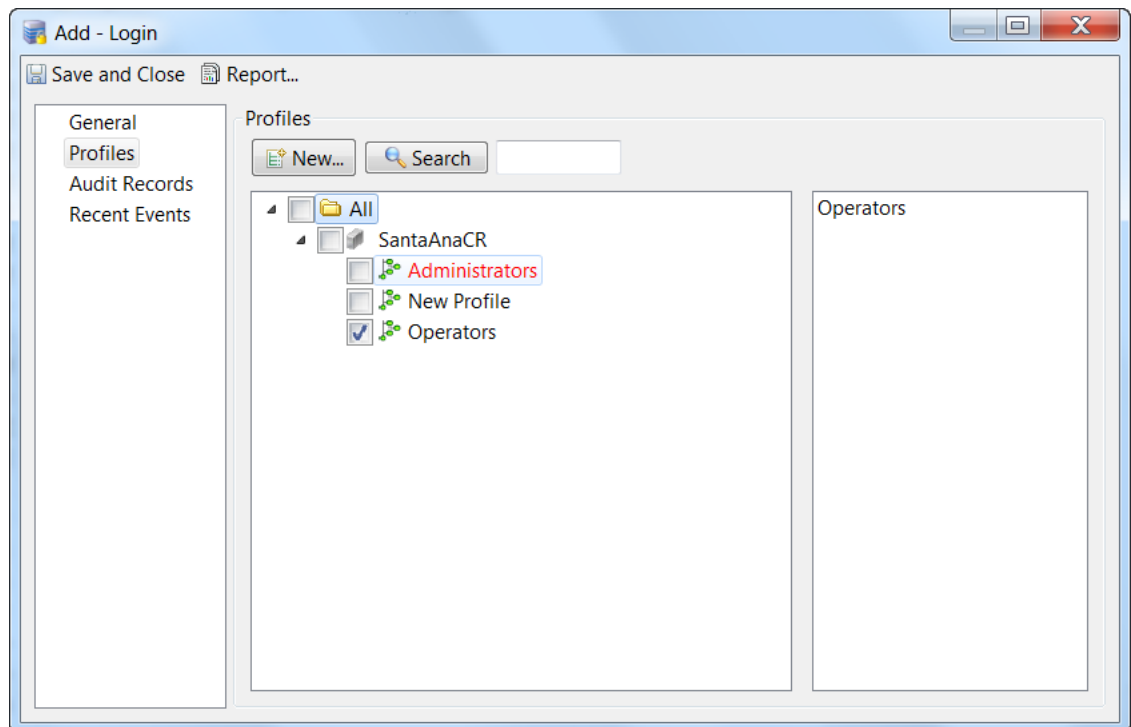

- b. To create a new profile, click the **New...** button.

The **Add Profile** dialog appears, as shown in [Figure 4-11](#).

Figure 4-11 Add Profile dialog (from the New button on the Add Login dialog's Profiles page)

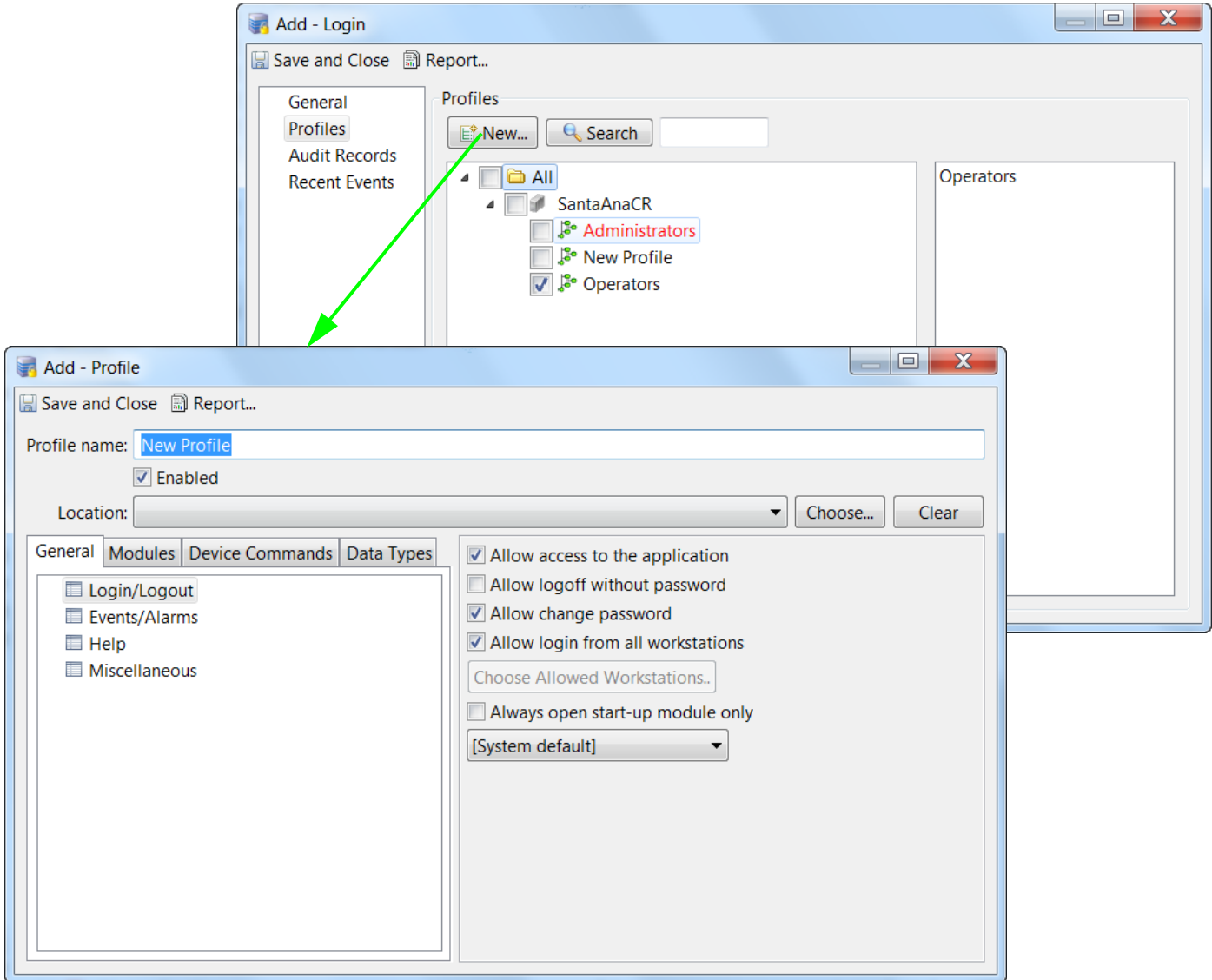

- c. Create a new profile, as explained in the [“Defining User Profiles for Desktop Application Access”](#) section on page 4-1.
- d. Click **Choose** to associate the profile to a specific location in the location hierarchy.
- e. Click **Save and Close** to save the new profile and close the **Add Profile** dialog.
- f. Back in the **Add Login** dialog, click **Save and Close** to save the new login and close that dialog.

**Step 5** To verify the changes, log off and then log in with the new username and password. Verify that the appropriate devices are populated for this location-restricted user.

## Additional Information

- If you do not associate a profile to a login, the user will not be able to log in into the system.
- When a login is associated with a profile without any location, the user associated with that profile is not bound to any hierarchical location and can access devices from all locations.
- Existing logins that have the administrator profile will continue to have the privileges of the administrator. It is the responsibility of the cpamadmin to unassign the administrator profile from these logins if required.

**Note**

---

If you do not select the options that associate locations to logins (as described in [Logins page of the System Configuration window, page 17-11](#)), the user actions are not restricted to specific locations.

---

# Configuring LDAP User Authentication

To authenticate users using a Lightweight Directory Access Protocol (LDAP) server, perform the following procedures:

- [Configure the LDAP Server, page 4-14](#)
- [Create the LDAP User Account in ICPAM, page 4-18](#)

## Configure the LDAP Server

Specify the LDAP server settings needed to configure the LDAP server connection and user authentication, as explained in the following instructions.

**Step 1** Choose the **Admin > System Configuration** command.

**Step 2** On the resulting **System Configuration** window, select the **LDAP** item in the left pane.

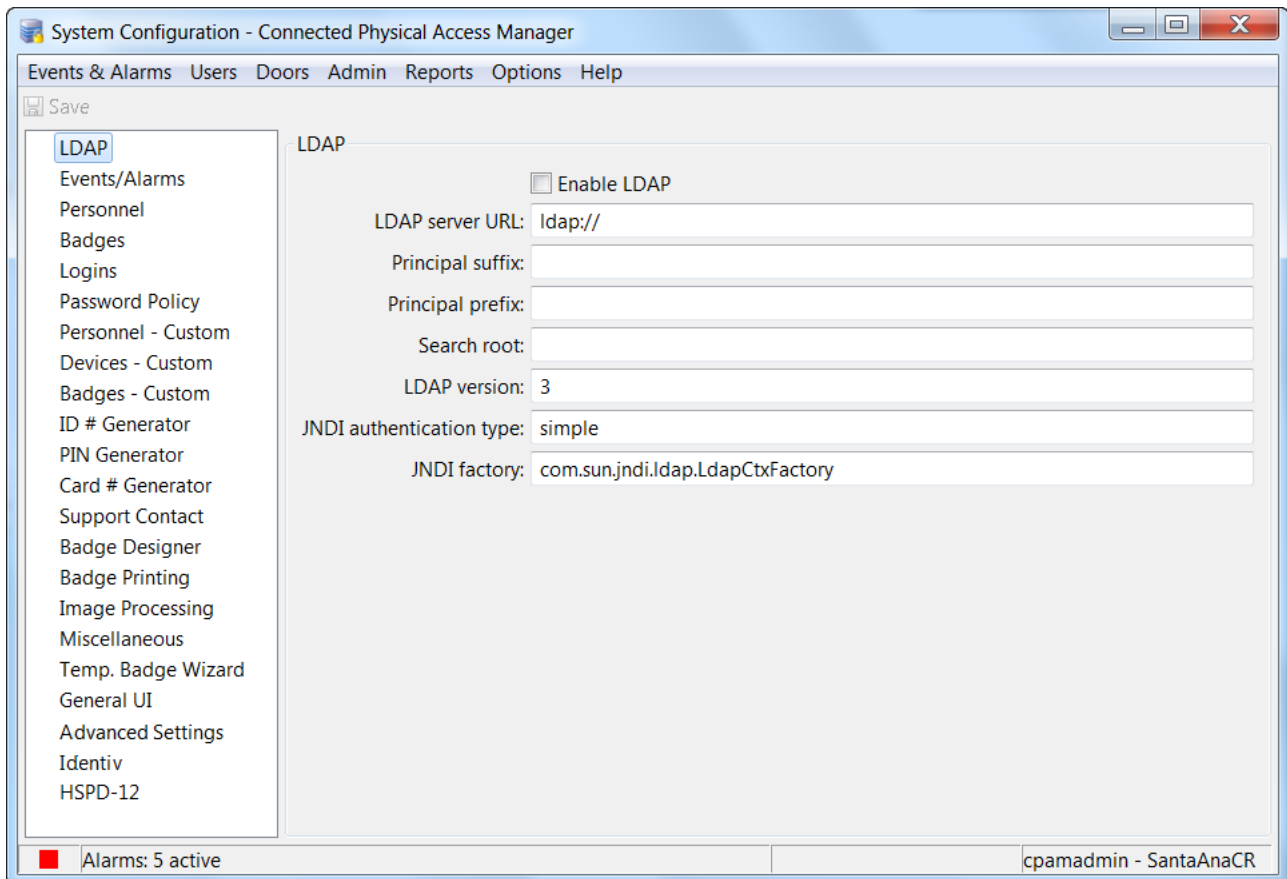

**Step 3** Enter the LDAP user authentication settings.

The LDAP configuration depends on the authentication mode selected:

- **User principal name** (recommended method). The user principal name is unique within the organization.
- **sAMAccountName**. The samaccount username is unique only in the search domain.

LDAP uses a principal name to authenticate, which is built from the username in the form:

prefix + username + suffix

The exact format of the principal name varies based on the type of LDAP server, and the domain. For OpenLDAP, the prefix should be: **uid=** and the suffix should be changed to reflect the actual domain. So for my-domain.com, this would be:

`,dc=my-domain,dc=com`

For more information, see the following topics:

- [LDAP Example: User Principal Name, page 4-16](#)
- [LDAP Example: sAMAccountName, page 4-17](#)

**Step 4** Enter the other LDAP server settings (as described in [Table 4-4](#)):

*Table 4-4 System Configuration dialog - LDAP page settings*

Option or Field	Description
<b>Enable LDAP</b>	Click on this check box to toggle between enabling or disabling LDAP support.
<b>LDAP server URL</b>	Type the URL of the LDAP server, which must begin with <code>ldap://</code> Example: <code>ldap://192.168.1.1:389</code> <b>Note</b> 389 is the port number.
<b>Principal suffix</b>	Specify the suffix which will be appended to the username to create the principal name for authentication.
<b>Principal prefix</b>	Specify the prefix which will be prepended to the username to create the principal name for authentication.
<b>Search root</b>	Specify the LDAP search root. The search root is the node in the LDAP tree, the subtree under which the user account should be found. <ul style="list-style-type: none"> <li>• For Active Directory, the dc components should be changed to match the full domain name managed by the directory. The following example is for my-domain.com: <code>cn=Users,dc=my-domain,dc=com</code></li> <li>• For OpenLDAP, the two dc components should be changed to match the full domain name managed by the directory. The following example is for my-domain.com: <code>dc=my-domain,dc=com</code></li> </ul>
<b>LDAP version</b>	This is an advanced setting that generally should be left unchanged.
<b>JNDI authentication type</b>	This is an advanced setting that generally should be left unchanged as <b>simple</b> .
<b>JNDI factory</b>	This is an advanced setting that generally should be left unchanged as <code>com.sun.jndi.ldap.LdapCtxFactory</code>

**Step 5** Stop and then restart the ICPAM application from the Web admin page, to enable the changes.

## LDAP Example: User Principal Name

In the example shown in [Figure 4-12](#), the user principal name is `cpsm.user@ad1.cpam1ab`. The ICPAM user login must be the same (`cpsm.user`).

*Figure 4-12 LDAP Configuration Example: User Principal Name*

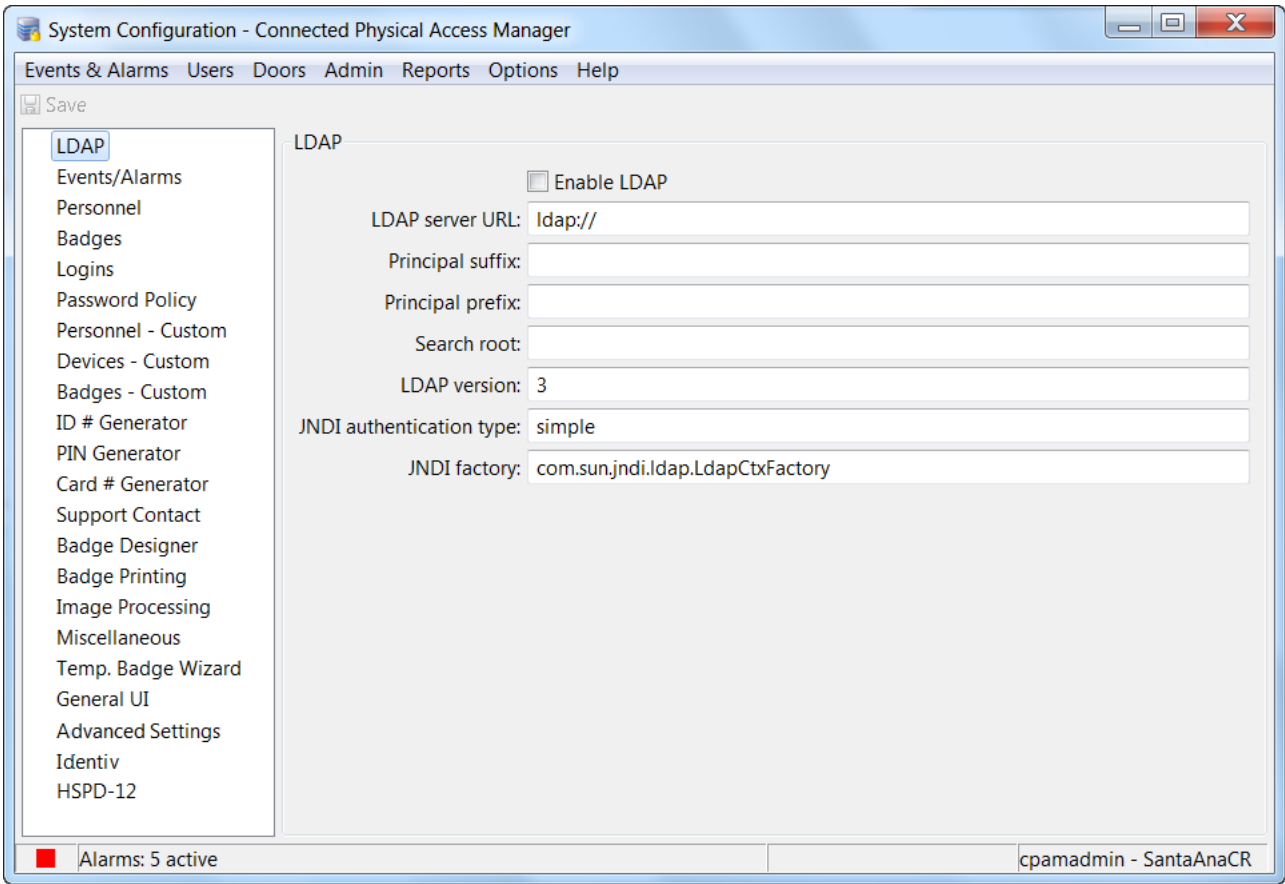

## LDAP Example: sAMAccountName

In the example shown in [Figure 4-13](#), the user login is the same as the samaccount name (`cpmuser`).

*Figure 4-13 LDAP Configuration Example: sAMAccountName*

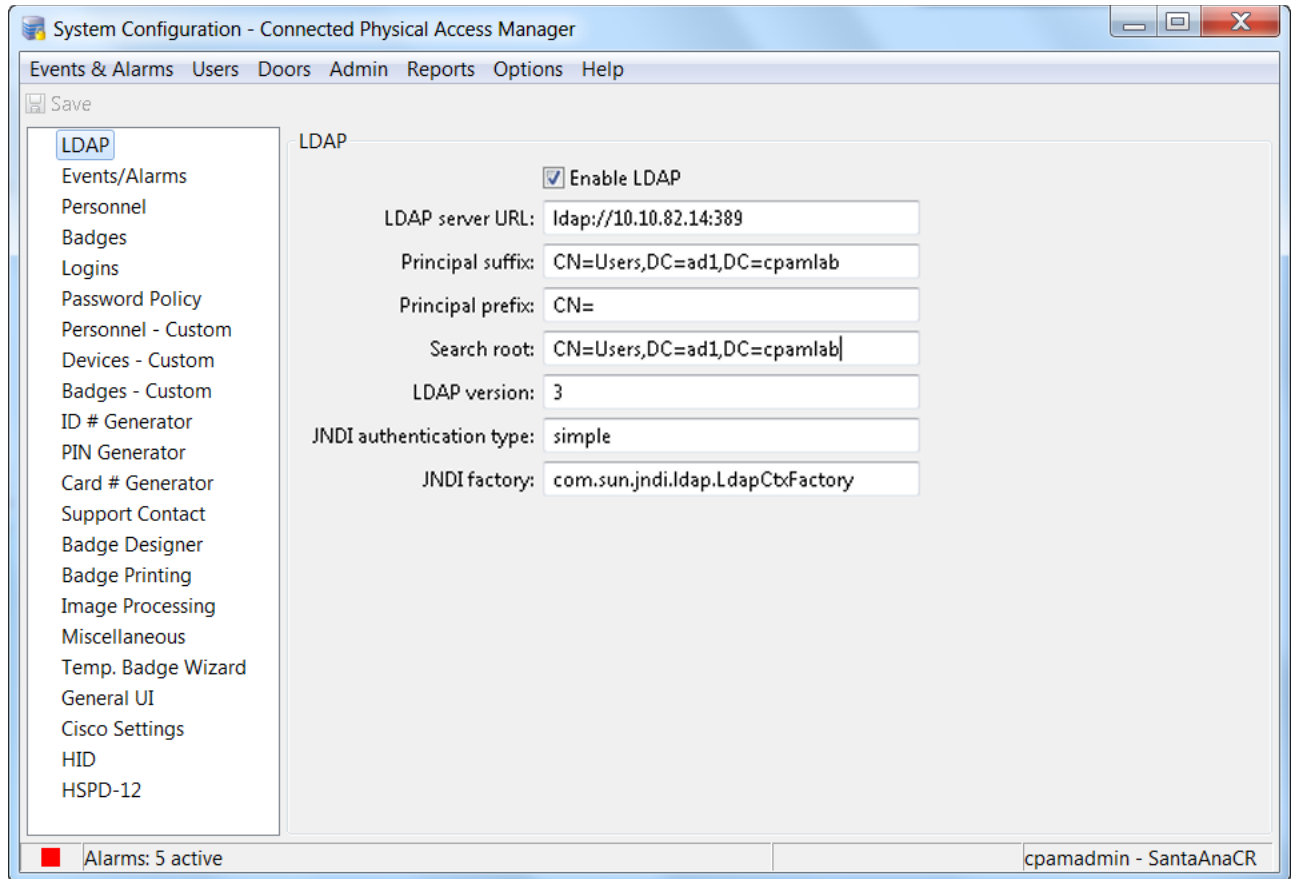

## Create the LDAP User Account in ICPAM

Create the user account to be authenticated using an LDAP server, as explained in the following instructions.

- Step 1** Choose the **Users > Logins** command.
- Step 2** On the resulting **Logins** window, either click the **Add** button, or select an existing login and click the **Edit** button.
- Step 3** On the resulting dialog, select the Login type of **LDAP**. The **Login type** field appears only if LDAP was enabled and the ICPAM application was restarted (see [Configure the LDAP Server, page 4-14](#)).

The screenshot shows the 'Edit - Login' dialog box. The left sidebar contains a tree view with 'General' selected, and other options like 'Profiles', 'Audit Records', and 'Recent Events'. The main area is titled 'General' and contains the following fields and controls:

- Username:** Joshua Grant
- Password:** Masked with 10 dots
- Confirm password:** Masked with 10 dots
- Service login only
- Location:** Identiv, Inc. (dropdown menu) with 'Choose...' and 'Clear' buttons.
- Assigned to:** (text field) with 'View...' and 'Select...' buttons, and a 'Clear' button.
- Validity:** Active (dropdown menu)
- Effective:** (text field) and **Time:** (text field)
- Expires:** (text field) and **Time:** (text field)
- Comments:** (text area)

- Step 4** Enter the username, password, and other settings for the LDAP login. See [Creating User Login Accounts and Assigning Profiles, page 4-9](#).



**Note** Although a password must be entered for all user Login records, it is not used for LDAP authentication. LDAP servers use the password entered when the user logs in to ICPAM.

- Step 5** Click the **Profiles** item in the left pane, and select the user's ICPAM profiles on the resulting page. See [Defining User Profiles for Desktop Application Access, page 4-1](#) for more information.



**Note** ICPAM does not synchronize the LDAP profiles.

- Step 6** Click **Save and Close**.



## Viewing Audit Records for Changes to Usernames

An audit record is generated every time a user adds, deletes, or modifies a Login entry. To view these audit records, perform the following steps.

- Step 1** Choose the **Users > Logins** command.
- Step 2** On the resulting **Logins** window, either double-click on a username entry, or select a username entry and click the **Edit** button.
- Step 3** On the resulting dialog, click on the **Audit Records** item in the left pane.

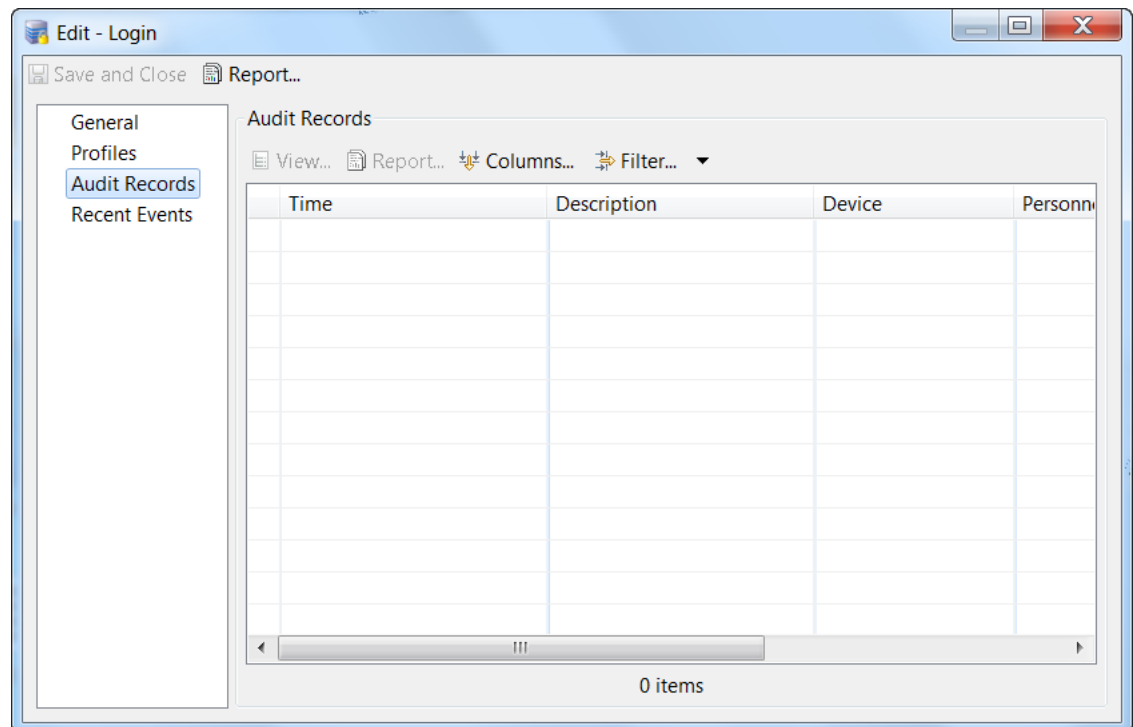

The **Audit Records** table on the right pane shows the audit records for the selected login. [Table 4-5](#) briefly describes the fields of an audit record.

Table 4-5 Logins module: Audit Record fields

Field	Description
<b>Time</b>	The time and date when the modification occurred.
<b>Time Received</b>	The time and date when the modification was saved.
<b>Site</b>	The site where the modification occurred. A site corresponds to a single instance of an ICPAM database.
<b>Type</b>	The type of change.
<b>Log code</b>	An abbreviated code uniquely identifying the type of change.
<b>Priority</b>	A priority used for sorting events and alarms. Positive priorities are above normal priority, while negative priorities are below normal priority. Zero is normal.
<b>Description</b>	A description of the change.
<b>Device</b>	The workstation name where the modification occurred. Click <b>View</b> to display details for the device where the change was made, including the IP address of the workstation device.
<b>Credential</b>	The username used when the modification occurred. Click <b>View</b> to display and revise details for the username.
<b>Personnel record</b>	The name of the operator associated with the modification (if the login was associated with a personnel record at the time).
<b>Data</b>	Additional information about the modification.
<b>View Current...</b>	Opens a new window displaying the current settings.
<b>View Before...</b>	Opens a new window displaying the settings before the change was made.
<b>View After...</b>	Opens a new window displaying the settings after the change was made.

## Managing Desktop Client Passwords

- [Changing Your Password, page 4-21](#)
- [Changing Another User's Password, page 4-21](#)
- [Managing the cpamadmin Login and Password, page 4-21](#)

**Tip**

To determine password expiration and strength requirements, see [Password Policy page of the System Configuration window, page 17-13](#).

## Changing Your Password

To change the password for the account currently logged in to the system, do the following:

- 
- Step 1** Choose the **Options > Change Password** command.
  - Step 2** Type your old password.
  - Step 3** Type a new password, then type the new password again to confirm the setting.
  - Step 4** Click **OK**.
- 

## Changing Another User's Password

To change another user's password, you must edit the Login record for that user. For instructions, see [Creating User Login Accounts and Assigning Profiles, page 4-9](#).

**Note**

You must have the required access privileges for the Login module to change passwords.

## Managing the cpamadmin Login and Password

The `cpamadmin` login and password are created during the initial server setup, as described in [Chapter 2, "Configuring and Monitoring the ICPAM Server"](#). After the initial setup, however, the `cpamadmin` login and password for the desktop client are managed independently of the server login, so changes to the desktop login do not affect the server login. See [Changing or Recovering the Server Password, page 2-40](#) for more information.

To retrieve a lost password for the `cpamadmin` user on the desktop client, log in with another user's account that has administrator privileges, and then reset the `cpamadmin` user password.



# Understanding Controller and Door Configurations

This chapter describes the concepts used to configure controllers, doors, and their respective templates. A door configuration is a collection of devices, such as locks and readers, connected to a controller and configured in ICPAM. To configure a door, add a controller to ICPAM and then assign one or more door configurations to the controller using the pre-defined door templates. Door configuration templates include common sets of devices and configurations to simplify access control configuration. Controllers and the associated doors can be configured either before or after the controller is added to the network.



**Tip**

---

See [Installation and Configuration Summary, page 1-3](#) for a quick summary of tasks.

---

Door configurations can only include devices not assigned to another door. The configuration wizard only displays unassigned devices. See [Chapter 8, “Configuring Door and Device Templates”](#) for more information.

## Contents

- [Provisioned \(Pre-Populated\) vs. Discovered Controller Configurations, page 5-2](#)
- [Viewing Device and Door Configuration, page 5-3](#)
- [Viewing Device and Door Status, page 5-11](#)
- [Understanding Door Configurations and Templates, page 5-23](#)
- [Understanding Door Modes, Door Schedules, and the First Unlock Feature, page 5-28](#)
- [Locating Serial Numbers, page 5-40](#)
- [Related Documentation, page 5-41](#)

# Provisioned (Pre-Populated) vs. Discovered Controller Configurations

You can configure a Gateway in ICPAM before or after the module is added to the network.

- [Provisioned \(Pre-Populated\) Configuration, page 5-2](#)
- [Discovered Configuration, page 5-2](#)



Note

---

See also [Configuration Management in Provisioned vs. Discovered Configurations, page 7-16](#).

---

## Provisioned (Pre-Populated) Configuration

A *provisioned* configuration occurs when a Gateway configuration is entered in ICPAM before the module is brought online. If the controller serial number matches the existing ICPAM configuration when the module is added to the network, ICPAM automatically downloads the existing configuration to the module.

- Subsequent changes to the configuration must be manually applied, as described in [Applying Configuration Changes, page 7-14](#).
- If the controller connects to ICPAM and does not have a configuration (such as after a hard reset), the latest configuration applied to that controller is downloaded.

## Discovered Configuration

A *Discovered* configuration occurs when a controller is added to the network and no ICPAM configuration exists. ICPAM automatically creates a new entry based on the module serial number and the serial numbers of any attached expansion modules.

The controller is assigned a name based on “gw\_” and the serial number. For example, if the controller serial number is FHH112900XX, the name of the discovered controller configuration in ICPAM will be gw\_FHH112900XX.

After the controller is added, complete the module and door configuration as described in [Chapter 7, “Configuring Doors”](#).



Note

---

The serial number for each Gateway and expansion module is unique and cannot be changed. In a Discovered configuration, the serial numbers are automatically sent from the module to the ICPAM appliance over the IP network. If the serial number for the controller or an attached expansion module already exists in the ICPAM configuration, the controller is not added.

---

# Viewing Device and Door Configuration

A door configuration is a collection of devices, such as locks and readers, connected to a controller or gateway and configured in ICPAM. To configure a door, add a controller to ICPAM and then assign one or more door configurations to the controller using pre-defined door templates. Door configuration templates include common sets of devices and configurations to simplify access control configuration.

Once the controllers and door configurations are added to ICPAM, you can view the configurations in a device view that lists the controllers, expansion modules, and interfaces, or in a Locations view, that displays the door configurations in a hierarchical location map.

This section includes the following information.

- [Viewing Doors and Devices in the Hardware Tree View, page 5-4](#)
- [Hardware Manager in ICPAM 2.1, page 5-6](#)
- [Viewing Doors and Devices by Location, page 5-7](#)
  - [Creating the Location Map, page 5-8](#)
  - [Changing the Location of a Device or Door, page 5-9](#)
  - [Location-Restricted User Permissions, page 5-10](#)

## Viewing Doors and Devices in the Hardware Tree View

The Device view in the Hardware Tree module displays a list of configured Gateways, expansion modules, and other devices in a hierarchical tree, as shown in [Figure 5-1](#).

To open the device view, select **Hardware Tree** from the **Doors** menu. In the Hardware Tree window, select **Device** from the **View** menu. Controllers are listed by name (such as Cisco Gateway or EM-100 Controller) and represented by a blue icon, as shown in [Figure 5-1](#). Click the box next to the icon to expand the hierarchical tree and view the expansion modules and other devices associated with the Gateway.

**Figure 5-1** Expanded Hardware Tree: Controllers and Related Devices



**Note**

Some devices, such as tamper inputs, fire sensors, and cameras, are not part of door configurations.



**Tip**

The names of all hardware tree elements are editable, including drivers, controllers, expansion modules, and door devices.



Table 5-1 describes the icons and drivers shown in Figure 5-1:

Table 5-1 Elements of the Device Tree

#	Type	Description
1	Site Location	Read-only. A site location corresponds to a single instance of an ICPAM database. It generally, but does not necessarily, correspond with a single geographical location, such as a building complex, building, or part of a building. Most installations of ICPAM only have a single database, and hence a single site location. Multiple locations are used in larger configurations, such as a company with offices in distant locations that have a separate ICPAM database at each office.
2	Driver Manager	Read-only. The Driver Manager enables ICPAM hardware and software drivers, such as the GW Driver, Identiv EM-100 Driver, Automation Driver, Cisco VSM Driver, or the EDI Driver. The Driver Manager cannot be deleted.  <b>Note</b> If you disable the Driver Manager then all the drivers, doors, gateway controllers and expansion modules are also disabled. If you later re-enable the Driver Manager, then you need to manually re-enable all driver modules, gateways, doors, and expansion modules.
3	Access GW Driver	The Access GW Driver allows you to add Cisco Physical Access Gateway hardware modules to the system configuration, and supports the additional expansion modules (reader, input and output) connected to a Gateway. The Access GW Driver also manages the events and alarms generated by devices, modules, and Gateways. The Access GW Driver is enabled by default.  <b>Note</b> The access controller driver is an example of a device driver. Device drivers enable software and hardware functionality. Additional device drivers include the Automation Driver, EDI Driver, and Cisco VSM Driver. Each of these drivers enables the functionality for that feature, and provides basic configuration settings. There can only be one instance of each driver.
4	Gateway Controller	A gateway is added for each controller device. The modules and devices configured on the gateway are listed below the gateway and include the gateway controller module, any expansion modules and the other devices attached to the module interfaces. Figure 5-1 shows an example hardware tree with the gateways, expansion modules, and other devices.  To add a gateway to the configuration, right-click on the Access GW Driver and select <b>New Gateway Controller</b> .
5	Access Control Modules	Modules include the gateway, reader, input, and output modules. Each configured module is listed under the controller, including the controller itself.  <b>Note</b> The Gateway module is displayed by default. Expansion modules are displayed only if added to the configuration. For information and instructions to install modules, see the <i>Cisco Physical Access Gateway User Guide</i> . For instructions to configure modules, see Chapter 7, “Configuring Doors”.
6	Module Interface	Each module includes a set of interfaces for connecting door hardware and other devices. For descriptions of each module interface, see the <i>Cisco Physical Access Gateway User Guide</i> .
7	Devices	Devices include hardware such as card readers and locks. Device configurations are applied using pre-defined templates, or for a specific interface. See Chapter 7, “Configuring Doors” and Chapter 8, “Configuring Door and Device Templates”.
8	Identiv Driver	Devices associated with the EM-100 controller.  For more on this, refer to <a href="#">Modifying Identiv EM-100 Drivers</a> , page 6-58.

## Hardware Manager in ICPAM 2.1

Starting with ICPAM 2.1, if the profile enhancement feature is set in the system configuration settings ([Logins page of the System Configuration window, page 17-11](#)), the following changes are impacted in this module:

- The Hardware Tree module displays the controllers, expansion modules, and other devices based on the user's hierarchical location only.
- The controller and the associated doors must be in the same location of the location-restricted user for the seamless operation of the profile enhancement feature.
- The respective local host and physical driver – Access GW Driver and local host – is populated only if the gateway or door is assigned to the location-restricted user's location.
- A location-restricted user is restricted from creating doors.
- A location-restricted user does not have access to the EDI and the Historical Events drivers. To provide access to these drivers, the cpadmin has to assign appropriate locations to these drivers and associate these locations to the location-restricted user.
- If the door is in one location and the (related) controller is in another location (not of the location-restricted user), the controller is still visible to the location-restricted user and the user can execute commands on this controller.



---

### Note

- The **Export** option fetches values of all unprivileged devices.
  - A location-restricted user is allowed to create doors using the gateway template module.
- 



---

### Note

These points are applicable only when the profile enhancement feature is set on the **Logins** page of the **System Configuration** window (starting with the ICPAM 2.1 release); otherwise, the ICPAM appliance retains its behavior as in the previous version (CPAM 1.5.1).

---

## Viewing Doors and Devices by Location

Because Gateways and related equipment are installed for specific locations, you can view door configurations in a hierarchical location map, as shown in [Figure 5-2](#). This map is available in both the Hardware Tree module and the Door/Location-based Hardware module of the Doors menu.

The location map can represent doors as they are organized in the real world. For example, if an organization has a campus in Bangalore, and another in San Jose, you can create a hierarchical map for each location, and assign the door configurations to a campus, building, floor, area, or sub-area. You can name the locations as needed, and place the doors at any level of the location hierarchy.

[Figure 5-2](#) shows an example of the location view in the Hardware Tree module. Select **Location** in the **View** menu to display the map. Although you can modify the door configurations from this view, you cannot change the location map. See [Creating the Location Map, page 5-8](#) for more information.

**Figure 5-2** Hierarchical Location View of Door/Location-Based Hardware

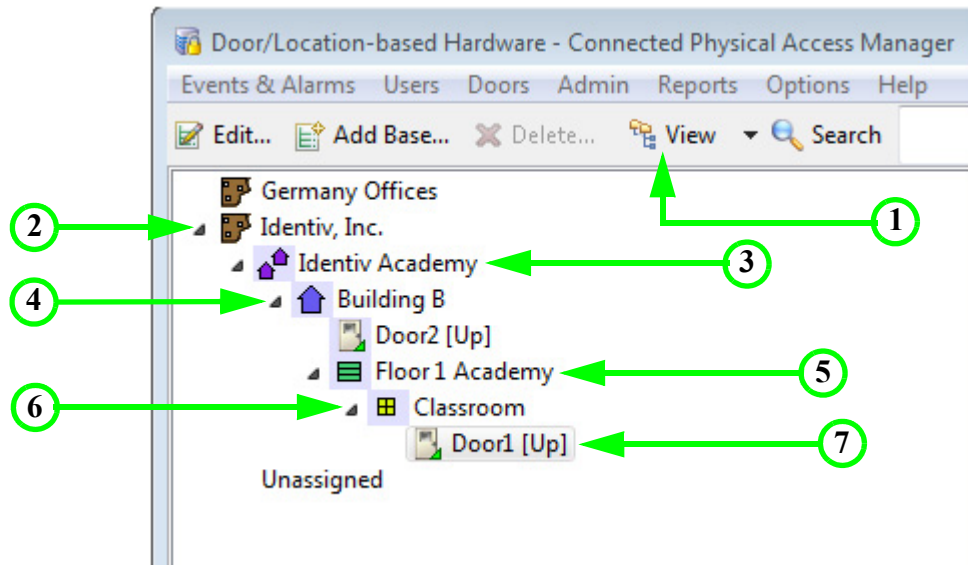

1	View options button	5	Floor
2	Base	6	Area
3	Campus	7	Door
4	Building		



### Tip

- Door configurations can be assigned to any level of the hierarchical map.
- You can drag-and-drop controllers and doors from one location to another.

## Creating the Location Map

To create or modify the location map for door configurations, select the **Doors > Door/Location-based Hardware** command. This map is also displayed in the Hierarchical Location view of the Hardware Tree module, as described in [Viewing Doors and Devices by Location, page 5-7](#).

[Figure 5-3](#) shows a sample location map. You can use any combination of map elements, such as campus, building, and floor.

Use the following methods to create and modify the location map.

- To create a new base, click the **Add Base...** button in the toolbar menu.
- To create a sub-location, right-click on a location and select **New [Element]** from the pop-up menu.
- To change the properties for an element, right-click on a location and select **Edit** from the pop-up menu.
- To add a door, right-click the driver appropriate to the controller (either EM-100 Driver or GW Access Driver) and select **Add Door...** For more on this, see [Chapter 7, “Configuring Doors”](#).

You can create any combination of location elements and doors can be assigned to any level of the hierarchical tree. For example, if a building has only one entrance, you can assign the door at the building level. For larger locations with multiple doors, you may need to assign a door to a specific floor or area within the building.

**Figure 5-3** Door/Location-based Hardware: Main Window

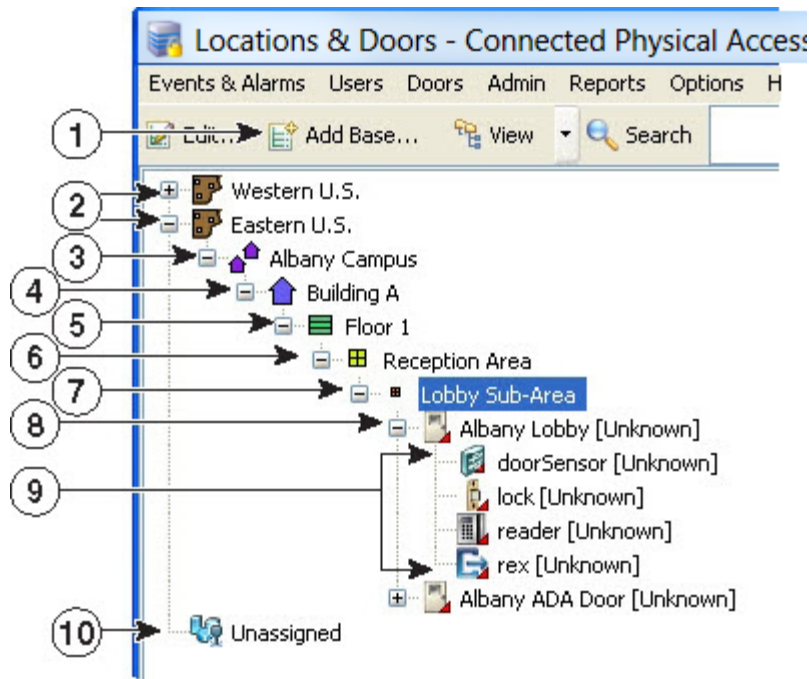

**Note**

Hierarchical locations cannot be deleted. Door and controller names must be unique.

1	Add Base... button	6	Area
2	Base	7	Sub-Area
3	Campus	8	Door
4	Building	9	Devices
5	Floor	10	Unassigned <sup>1</sup>

1. Unassigned includes Doors and Devices that are not assigned to a location.

## Changing the Location of a Device or Door

To change the location of a door or device (including controllers, input, and output devices), you can drag and drop the items in the location map, or edit the configuration, as described in the following steps.

- 
- Step 1** Select **Hardware Tree** or **Door/Location-based Hardware** from the Doors menu.
- **Door/Location-based Hardware:** Select a device or door from the **View** menu.
  - **Hardware Tree:** Select **Location** from the **View** menu.
- Step 2** Expand the location tree to view the device or door.
- Step 3** Change the location for the device or door:
- Drag and drop the device or door icon to a new location, and click **Yes** when the confirmation message appears.
- or
- Select the device or door and click **Edit**. In the Edit window, select the **Location** tab and choose a new **Location** from the drop-down menu, as shown in [Figure 5-4](#). You can also click the **Choose** button to select a location from the location map.

*Figure 5-4 Editing the Location for a Door or Device*

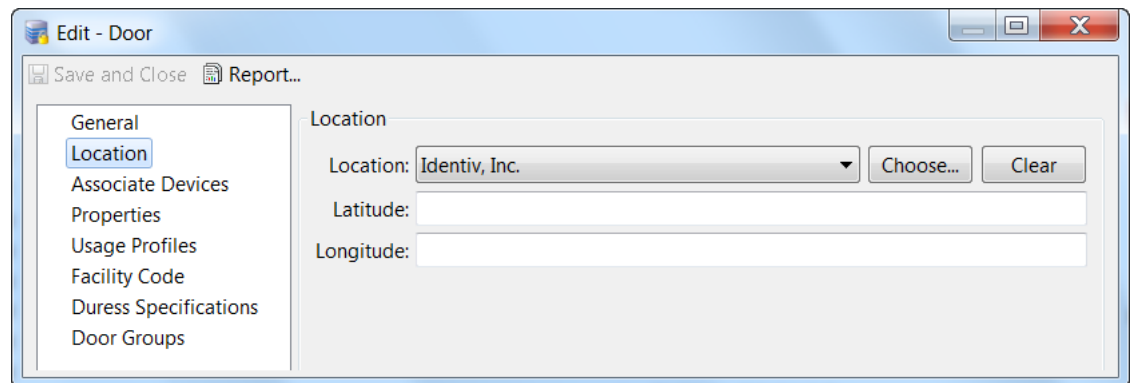

**Note**

If the location constraint is enabled ([Logins page of the System Configuration window, page 17-11](#)), the location-restricted users are allowed to change location to any location/sub location only under their hierarchical location.

## Location-Restricted User Permissions

Locations & Doors is the module where the location hierarchy is defined. The location hierarchy is defined as Base > Campus > Building > Floor > Area > Sub-Area.

After the profile enhancement feature is set in the system configuration settings ([Logins page of the System Configuration window, page 17-11](#)), the following changes are impacted in this module:

- A location-restricted user is able to view the entire hierarchy, but only the devices from the assigned location are populated for the location-restricted user.
- The doors are displayed to users based on hierarchical location assigned to their user profiles. For example: if a user profile “campusadmin” is assigned to a location “BVVC”, the user can view doors and devices related to this location and its sub-locations only. The action options for other locations (such as BVDC, for example) are grayed out (see [Figure 5-5](#)).

**Figure 5-5** Door/Location-Based Options for Unprivileged Nodes

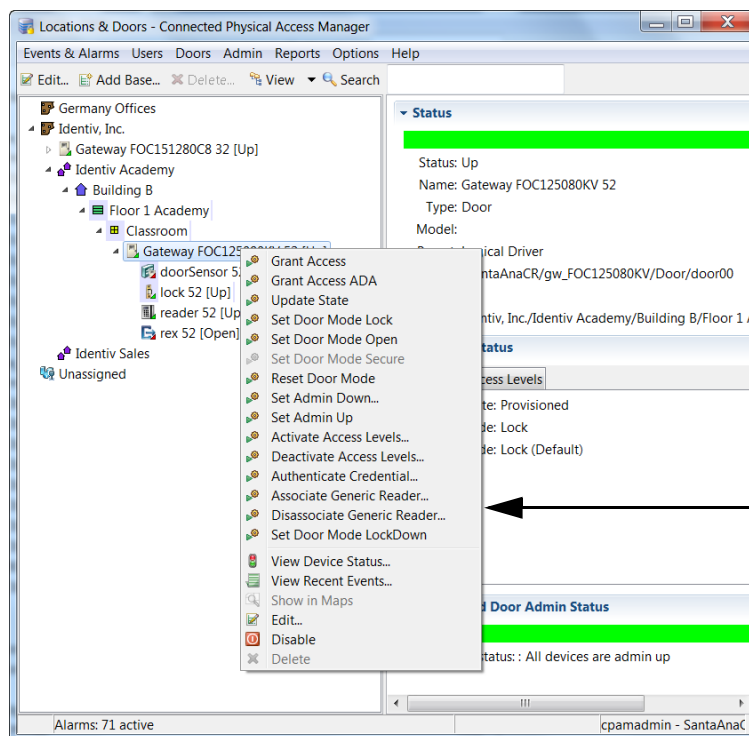

A location-restricted user cannot execute device commands on devices from unprivileged nodes.

- The **Unassigned** node (location) is only available for the cpamadmin and those logins who are not bound by hierarchical location.
- The location-restricted user will not be able to execute device commands on devices from unprivileged nodes.

- The Extended Status pane shows device information of assigned devices for the location-restricted user.

**Note**

If cpamadmin wishes to drag and drop a controller from one location to another, the cpamadmin should ensure that all interfaces and modules of the controller are pointed to the new location. This action will prevent the location-restricted user of the old location from accessing the controller.

**Note**

These points are applicable only when the profile enhancement feature is set on the **Logins** page of the **System Configuration** window (starting with the ICPAM 2.1 release); otherwise, the ICPAM appliance retains its behavior as in the previous version (CPAM 1.5.1).

## Viewing Device and Door Status

To view the status for a door or device use one of the options described in this section:

- [Viewing a Status Summary for All Devices, page 5-11](#)
- [Viewing the Status for a Single Door, Device, or Driver, page 5-13](#)
- [Monitoring Device Errors, page 5-16](#)
- [Viewing the Recent Events for a Device or Driver, page 5-17](#)
- [Generating a Gateway Driver System Sanity Report, page 5-18](#)

### Viewing a Status Summary for All Devices

Use the Device Status module to view status information for all doors, drivers, and devices.

**Step 1** Select **Device Status** from the **Doors** menu.

The Device Status window displays a status summary for all devices, as shown in [Figure 5-6](#).

Figure 5-6 Device Status: Main Menu

Name	Status	Type	Model	Usage	Parent	Address	Enabled	Top Alar...	Top Alarm Description
Access GW Driver	Started	Gateway...			Driver Manager loc...	localhost	Yes	Active	Configuration download t...
m00	Unknown	Gateway...	Default ...		Gateway 2	/SantaA...	Yes		
Gateway Door 2	Unknown	Door			Logical Driver	/SantaA...	Yes		
output03	Unknown	Gateway...			m00	/SantaA...	Yes		
Automation Driver	Started	Automa...			Driver Manager loc...	localhost	Yes		
EVO DR1 - Tamp...	Unknown	Input			EVO DR1 - Integrat...	3	Yes		
pwrfail01	Unknown	Gateway...			m00	/SantaA...	Yes		
Lock Gateway 2	Unknown	Lock			Door Lock Gatewa...	/SantaA...	Yes		
EDI Driver	Started	EDI Driv...			Driver Manager loc...	localhost	Yes		
Reader Door 2	Unknown	Reader			Gateway Door 2 R...	/SantaA...	Yes		
Door Lock Gatew...	Unknown	Gateway...			m00	/SantaA...	Yes		
EVO DR1 - REX	Unknown	REX			EVO DR1	2	Yes		
DR Contact Gate...	Unknown	Gateway...			m00	/SantaA...	Yes		
input03	Unknown	Gateway...			m00	/SantaA...	Yes		
Driver Manager l...	Started	Driver M...				localhost	Yes		
Logical Driver	Started	Logical ...			Driver Manager loc...	localhost	Yes		
EVO DR1 - Door ...	Unknown	Door Str...			EVO DR1	1	Yes		
EVO DR1 - Integr...	Unknown	Interfac...	Integrat...		EVO DR1 - Edge	0	Yes		
Historical Events ...	Copying	Historic...			Driver Manager loc...	localhost	Yes		
Gateway 2	Unknown	Gateway...	Cisco Ac...		Access GW Driver	/SantaA...	Yes		
LED Output Gate...	Unknown	Gateway...			m00	/SantaA...	Yes		
EVO DR1 - Door ...	Unknown	Door Co...			EVO DR1	1	Yes		
EVO DR1 - Batter...	Unknown	Input			EVO DR1 - Integrat...	5	Yes		
REX Gateway 2	Unknown	REX			REX Gateway DR 2	/SantaA...	Yes		
tamper01	Unknown	Gateway...			m00	/SantaA...	Yes		
EVO DR1 - A/C ...	Unknown	Input			EVO DR1 - Integrat...	4	Yes		

Alarms: 5 active | 36 items | cpamadmin - SantaAnaCR

**Step 2** (Optional) Use the toolbar buttons to filter or search the entries.

See [Toolbar Features](#), page 3-10 for more information.

**Step 3** (Optional) Double-click an entry to view additional status details for the device, as shown in [Figure 5-7](#).



Figure 5-7 Device Status: Detailed Status dialog

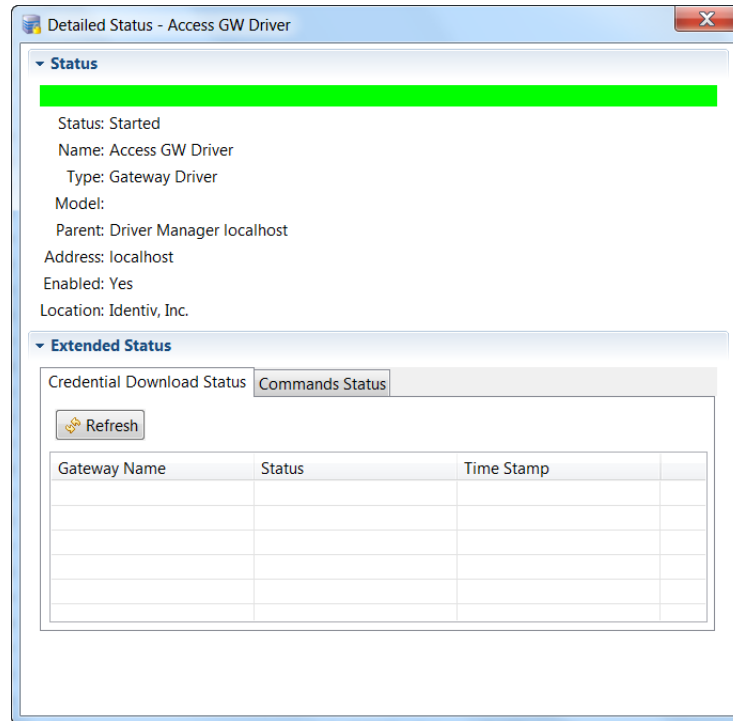

- Step 4** Click the tabs in the **Extended Status** pane to view any additional details for the device. The available tabs vary depending on the device type.

## Viewing the Status for a Single Door, Device, or Driver

- Step 1** Select **Hardware Tree** or **Door/Location-based Hardware** from the **Doors** menu.
- Step 2** (Optional) Use the toolbar buttons to filter or search the entries.
- Step 3** Select a door, device, or driver.

The **Status** and **Extended Status** panes appear in the right side of the window.



**Tip**

You can also right click a driver, device, or location, and select the **View Device Status** command from the pop-up menu.

Figure 5-8 shows an example for a door in the Locations & Devices module.

**Figure 5-8** Status and Extended Status in the Locations & Devices Module

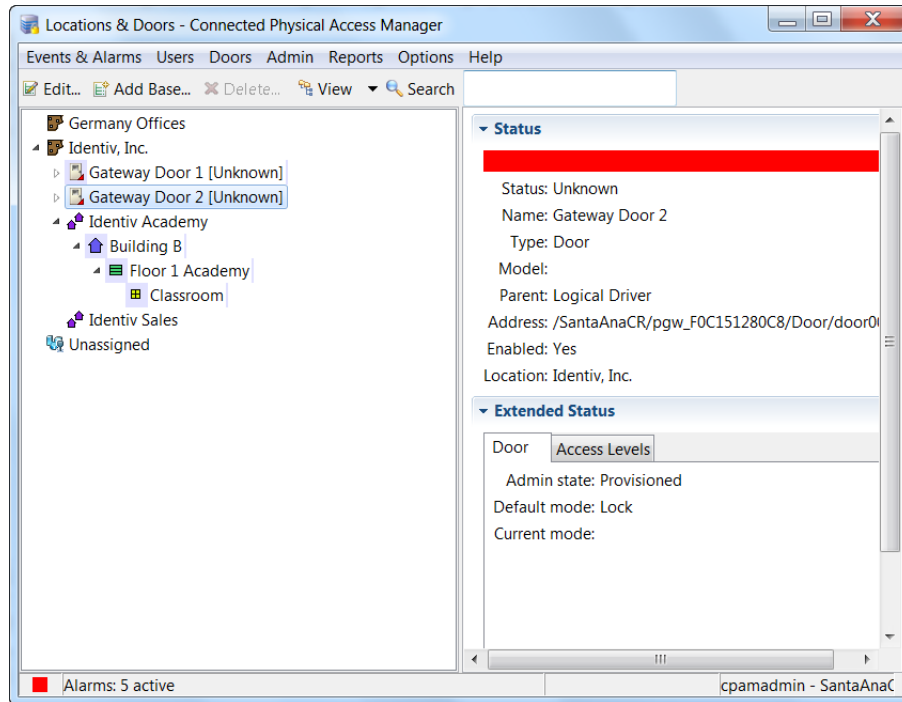

- Step 4** Click the tabs in the **Extended Status** pane to view additional details for the device. The available tabs vary depending on the driver or device type.

# Understanding Device Status Colors

The status of a controller, controller, door, or driver is signified by the color in the icon, and the color bar in the Status field, as shown in Figure 5-9.

Figure 5-9 Device Status Colors

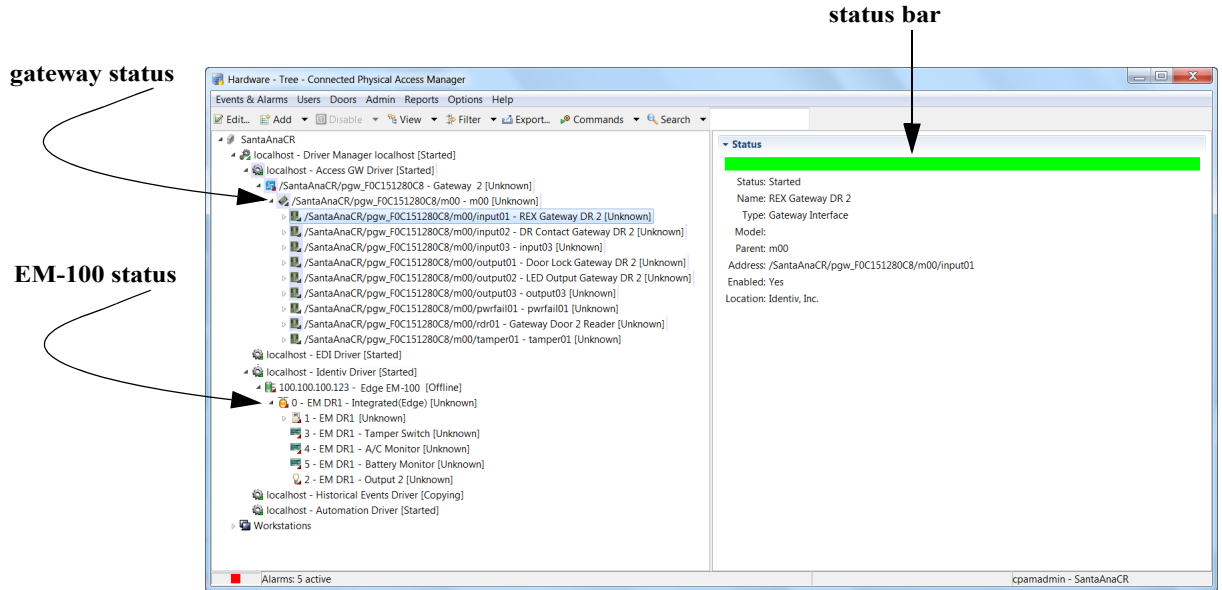

#	Color	Example	Description
1	Green		The device is Up and the configuration is current.
2	Dark Green		(Controllers and gateways only) The controller is Up, but has configuration changes that have not been applied (downloaded). See <a href="#">Applying Configuration Changes to Controllers, page 7-14</a> .
3	Red		The device is in Down or Unknown state.
4	Green, Dark Green, or Red		The Status bar color also signifies the device or door status.

## Monitoring Device Errors

To view a summary of the errors that occurred in the ICPAM system, do the following:

**Step 1** Select **Error Monitoring** from the **Admin** menu.

The main window displays a summary of the errors for all devices, as shown in [Figure 5-10](#).

By default, the errors are sorted chronologically, with the most recent appearing first.

*Figure 5-10* Error Monitoring main window

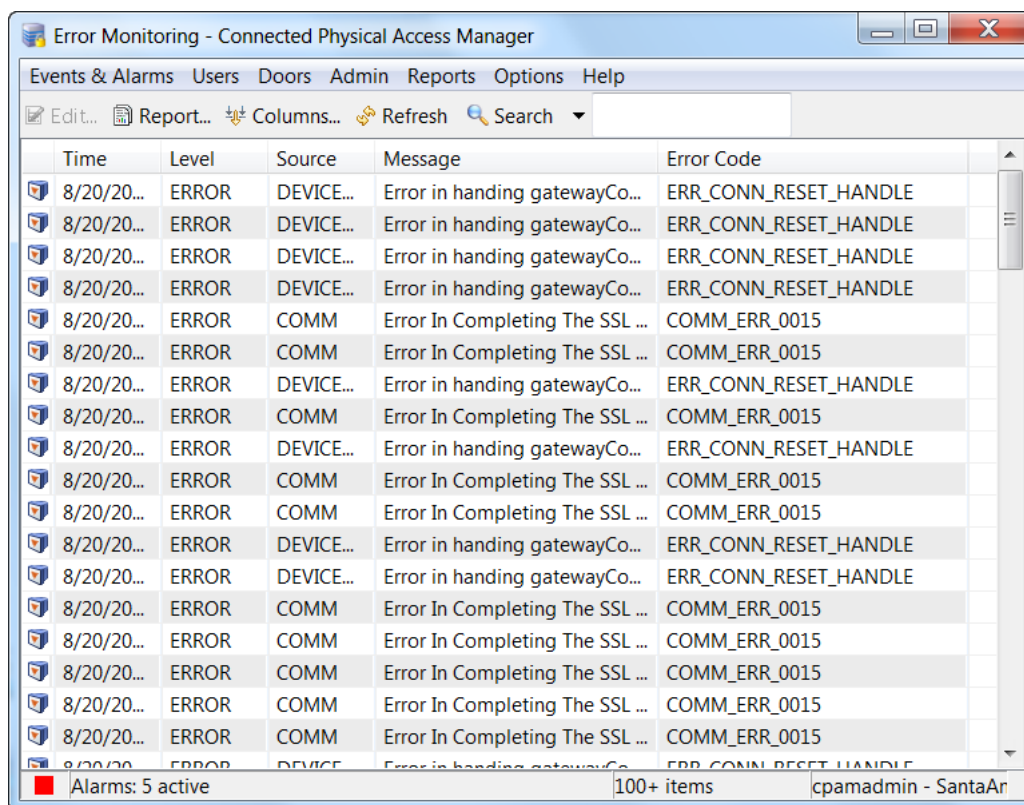

**Step 2** (Optional) Use the toolbar buttons to filter or search the entries.

See [Toolbar Features](#), [page 3-10](#) for more information.

**Step 3** (Optional) Double-click an entry to view additional status details for the device, as shown in [Figure 5-11](#).

**Figure 5-11 Error Monitoring: Detail Menu**

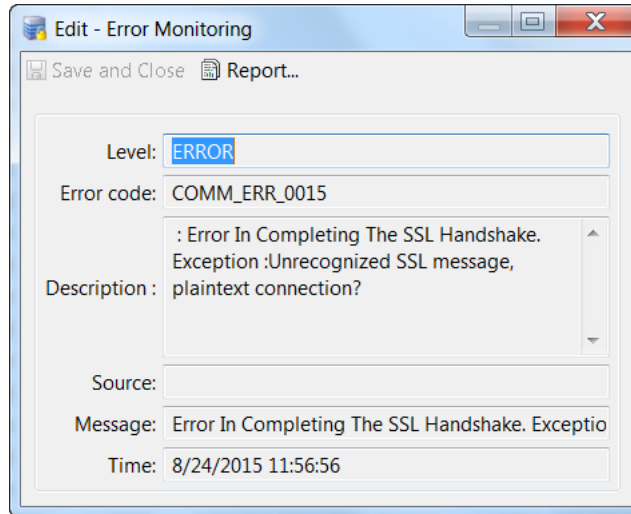

## Viewing the Recent Events for a Device or Driver

To view a list of recent events for a device or driver, do the following:

- Step 1** Select **Hardware Tree** or **Door/Location-based Hardware** from the **Doors** menu.
- Step 2** (Optional) Use the toolbar buttons to filter or search the entries. See [Toolbar Features](#), page 3-10.
- Step 3** Right-click on the device or driver, and select **View Recent Events** from the pop-up menu, as shown in [Figure 5-12](#).

**Figure 5-12 View Recent Events Menu**

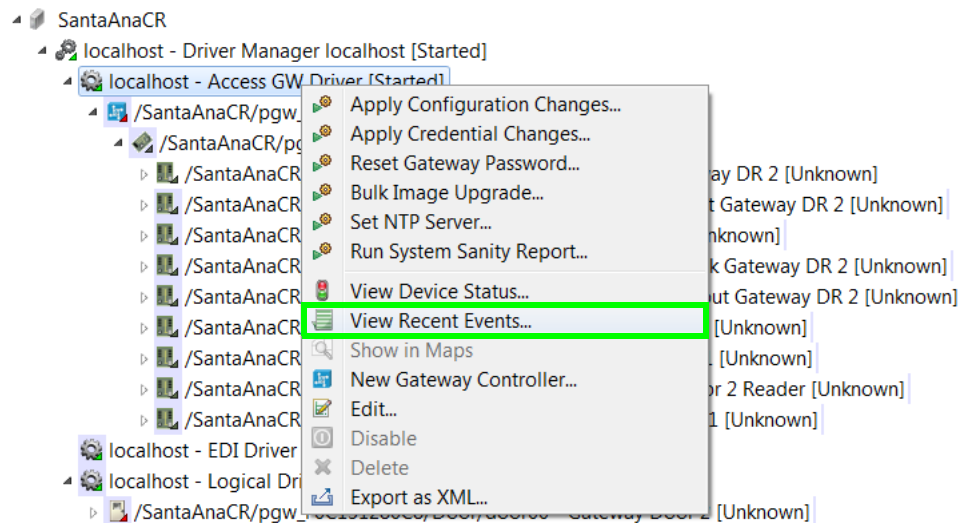

- Step 4** In the resulting window, double-click an event to view its event details, as shown in [Figure 5-13](#).

Figure 5-13 Recent Events

Time	Description	Device	Personnel Record	Credential	Data
8/19/2015 11:39:37	Gateway Driver: Started	Access GW Driver			
8/19/2015 11:39:37	Gateway Driver: Starting	Access GW Driver			
8/19/2015 11:38:57	Gateway Driver: Stopped	Access GW Driver			
8/19/2015 11:38:57	Gateway Driver: Stopping	Access GW Driver			
8/19/2015 09:45:55	Configuration download t...	Access GW Driver			Gateway Serial No : F0C151280B6 Res...
8/19/2015 09:45:49	Configuration download t...	Access GW Driver			Gateway Serial No : F0C151280C8 Res...
8/18/2015 15:32:55	Gateway Driver: Started	Access GW Driver			
8/18/2015 15:32:55	Gateway Driver: Starting	Access GW Driver			
8/18/2015 15:32:18	Gateway Driver: Stopped	Access GW Driver			
8/18/2015 15:32:18	Gateway Driver: Stopping	Access GW Driver			

See [Viewing Events, Alarms, and Audit Trail Records, page 12-2](#) for more information.

## Generating a Gateway Driver System Sanity Report

System sanity reports provide information about potential system inconsistencies. For example, it includes a summary of doors that are administratively `Down`, devices and doors that are disabled, and other information. Sanity reports can be viewed online, or saved to your computer in a variety of formats.

[Figure 5-14](#) shows a sample report.

Figure 5-14 System Sanity Report Example

Name	Type
ALL ACCESS POLICY	Access policies - Not assigned to any badge
Santa Ana Facility Access Policy	Access policies - Not assigned to any badge
1234 - [/SantaAnaCR/pgw_FOC151280B6]	Badges - Added (or changed) since the most recent download
1234 - [/SantaAnaCR/pgw_FOC151280C8]	Badges - Added (or changed) since the most recent download
7564 - [/SantaAnaCR/pgw_FOC151280B6]	Badges - Added (or changed) since the most recent download
7564 - [/SantaAnaCR/pgw_FOC151280B6]	Badges - Added (or changed) since the most recent download
1234 - [/SantaAnaCR/pgw_FOC151280B6]	Badges - Added (or changed) since the most recent download
7564 - [/SantaAnaCR/pgw_FOC151280C8]	Badges - Added (or changed) since the most recent download
	Badges - Not associated with any credential template
	Badges - Temporarily de-activated/Inactive state/Expired
	Badges not assigned to any personnel record
	Cameras that are offline
Tamper Sensor	Device templates - Not used
GlassBreak Sensor (NO)	Device templates - Not used
Duress Sensor (NO)	Device templates - Not used
10 Wire Wiegand Buffered KP	Device templates - Not used
Generic Output Template	Device templates - Not used
Fire Sensor (NC)	Device templates - Not used
Push Button Rex (NC)	Device templates - Not used
Generic Input (NO)	Device templates - Not used
Rex (NO)	Device templates - Not used
Generic Input (NC)	Device templates - Not used
Duress Sensor (NC)	Device templates - Not used
GlassBreak Sensor (NC)	Device templates - Not used
Motion Sensor (NO)	Device templates - Not used
10 Wire Wiegand Unbuffered KP	Device templates - Not used
Fire Sensor (NO)	Device templates - Not used
Power Fail	Device templates - Not used
/SantaAnaCR/pgw_FOC151280B6 - Classroom Door [Gateway Controller]	Devices/Doors - Disabled

**Tip**

You can also configure automated rules to automatically generate and send system sanity reports. Complete the instructions in [Configuring Global I/O Automated Rules, page 13-18](#) and select **Sanity Report Action** in the Actions field.

Sanity reports include the following topics:

- Doors that are administratively **Down**.
- Devices and doors that are disabled.
- Door templates that are not used in the system.
- Device templates that are not used in the system.
- Controllers with pending configuration changes.
- Doors not associated with any access policy.
- Doors set up with default mode **Open**.
- Door schedules that are not used.
- Door groups not associated with any access policy.
- Schedules that are not used.
- Workweeks, holidays, time entry collections, or time ranges that are not used.
- Access policies that are not assigned to any badge.
- Badges that are not associated with any credential template.

- Badges that are temporarily de-activated, inactive, or expired.
- Badges that are added or changed since the most recent download.
- Badges that are not assigned to any personnel record.
- Cameras that are offline.
- Controllers that are offline.
- Controllers that are set to a different time zone from the ICPAM.

### Procedure

To view and save system sanity reports, do the following:

- 
- Step 1** Select **Hardware Tree** from the **Doors** menu.
- Step 2** Right-click on the **Access GW Driver** and select the **Run System Sanity Report** command from the pop-up menu, as shown in [Figure 5-15](#).

**Figure 5-15** System Sanity Report Command

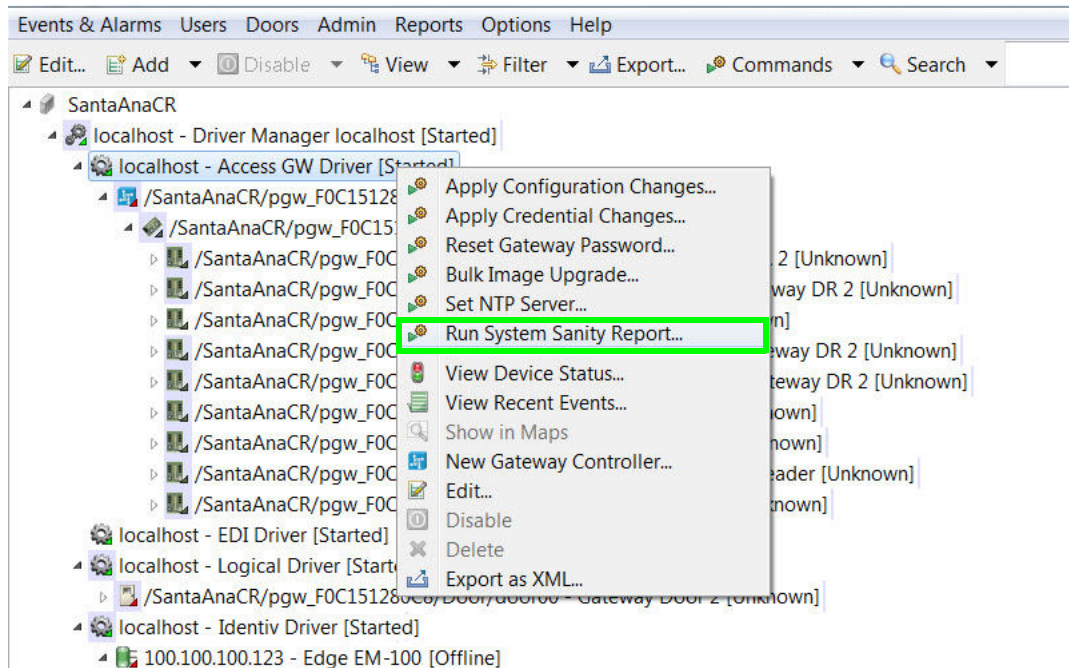

- Step 3** In the resulting **Sanity Report** window, expand the menu for a topic, as shown in [Figure 5-16](#).



Figure 5-16 System Sanity Report Window

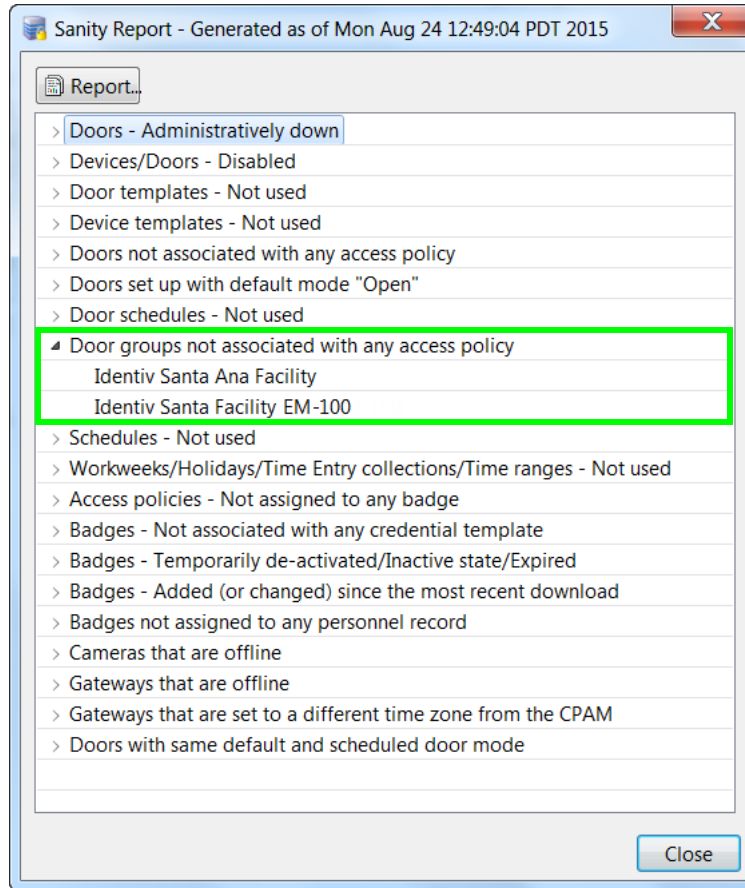

In [Figure 5-16](#), the topic `Door groups not associated with any access policy` is expanded to show that the `Lobby Door Group` is not associated with any access policy.

**Note**

If a topic does not display any information when expanded, then no criteria meets that condition.

- Step 4** (Optional) Open the sanity report in a separate window, or save it to your computer.
- a. Click the **Report** button, as shown in [Figure 5-16](#).
  - b. In the Report Generation window ([Figure 5-17](#)), select the **Format** for the report.

Figure 5-17 System Sanity Report Settings

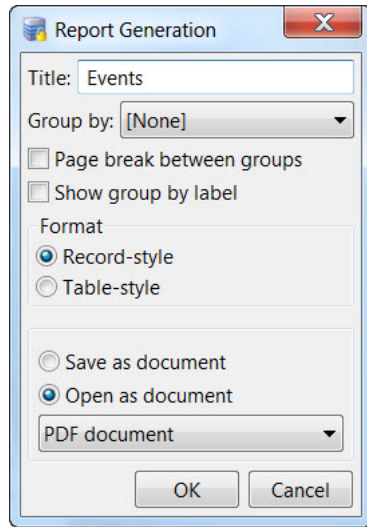

- c. Select the report output.
  - **Open in report**
  - **Save as document**
  - **Open as document**
- d. Select the document format from the drop-down menu (only if you chose to save or open the report as a document). For example: **PDF**.
- e. Click **OK**.
- f. If saving the report to a file, enter a file name, select the file location, and click **Save**.

**Note**

---

A sample sanity report is shown in [Figure 5-14](#) on page 5-19.

---

# Understanding Door Configurations and Templates

This section includes the following information

- [Overview, page 5-23](#)
- [Sequence for Configuring Templates and Doors, page 5-24](#)
- [Door Configurations and Templates, page 5-24](#)
- [Template Types, page 5-25](#)
- [Impact of Template Changes on Configured Doors and Devices, page 5-26](#)
- [Gateway Templates, page 5-26](#)
- [Understanding Door Templates, page 5-26](#)
- [Understanding Device Templates, page 5-27](#)
- [Understanding Virtual Credential Templates, page 5-27](#)
- [Understanding Gateway Credential Templates, page 5-28](#)
- [Understanding Reader LED Profiles, page 5-28](#)

## Overview

Configuring an access control system for a large number of doors can be complex and time consuming. For example, if an organization has 500 doors, each door may include a different set of devices and access control rules. Some doors may include only a lock, a reader, and a REX (request to exit) device, while other doors may also include sensors and cameras. Lobby doors may need to be unlocked during business hours, while others should remain locked and require badge access at all hours. If the requirements for a door or set of doors changes, the settings must be manually entered and tracked for each door.

To manage this complexity, ICPAM Manager supports door and device templates. Templates enable you to create standard configurations that can be applied to groups of doors.

For example, if all the lobby doors in your organization use a similar set of equipment and access control rules, and all lab doors use a different set of devices and configurations, you can create one door template for lobby doors, and a different one for lab doors. To create a door configuration, just assign the pre-defined door template to a controller.

Since a door configuration references a door template, all template settings or changes to those settings are reflected by the door. You can easily override most template settings for a single door by deselecting the Default check box next to each field and entering a custom value. The current door setting is changed, but the template and the other doors that reference that template are unaffected.

Using templates, a campus that includes 500 doors can be categorized into 10 different door categories (such as lobby, lab, and records). With ICPAM you create 10 different door templates instead of 500 individual door configurations. You also have full flexibility to change settings for a single door, or groups of doors.

## Sequence for Configuring Templates and Doors

Figure 5-18 outlines the main tasks to create templates and apply them to door configurations.

Figure 5-18 Sequence for Configuring Templates and Doors

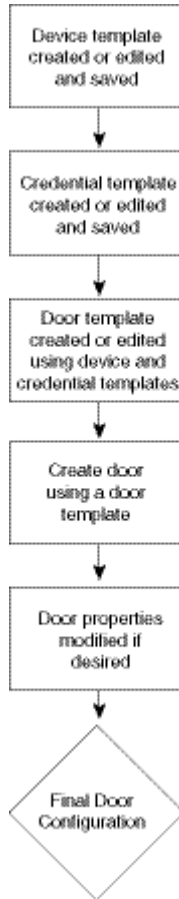

Tip

See also [Installation and Configuration Summary, page 1-3](#).

## Door Configurations and Templates

Door configurations are sets of device hardware assigned to a controller. Door configurations usually include the following devices:

- **Lock:** Used to lock the door.
- **Rex:** REX is an abbreviation for request-to-exit. A REX is a type of door hardware, typically a button that allows people to exit through an access point without using a badge. There are two types of REX buttons:
  - Push button REX: this button is used to trigger the system to directly unlock the lock associated with the door. For example, a Push Button REX fixed on a door latch is pressed to trigger the lock to open the door.

- Non-push button REX: A Non-Push Button REX has no effect on the lock associated with the door. For example, when a push bar on the door is pressed it retracts the door latch causing the door to open.
- **Reader:** A device used to read a user’s card credentials.
- **Door Sensor:** A device that senses if the door is open or closed.
- **Deadbolt:** An additional lock used for added security.
- **Door Swing:** A device used to open the door with a mechanical arm or other mechanism.

Door configurations are created by assigning door templates to a controller. Door templates contain pre-defined device configurations.

- [Adding New Doors, page 7-2](#): this method uses a step-by-step script that prompts you to add a controller to the system, create one or more door configurations, and assign a door template to each door. This is the quickest way to add a completely new set of hardware to the system.
- [Adding Doors Using Door Templates, page 7-3](#): using this method, the controller must already be entered in the system, usually after a [Discovered Configuration](#), or when adding an additional door configuration to an existing controller.

## Template Types

There are six different types of templates. Each template is as a building block to provide pre-defined configurations for the next level.

- [Gateway Templates](#): define basic attributes of the controller such as the time zone, support for one or two doors, the attached expansion modules, and the door templates assigned to the controller. Changes to a gateway template do not impact configured controllers (only new controller configurations).
- [Controller Templates](#): define the basic attributes of the Identiv EM-100 controller, such as time zone, support for doors, and door templates assigned to the controller.
- [Understanding Door Templates](#): define a set of door hardware devices and settings. Door templates are assigned to controllers to simplify door configuration. Door templates also reference device templates (see below) to simplify device configuration.



Note

---

Changes made to door, device, and credential templates also change any doors or devices configured with those templates.

---

- [Understanding Device Templates](#): define typical settings for devices, such as locks and sensors. Device templates are used to help define door templates.
- [Understanding Gateway Credential Templates](#): define the card data format for a reader, including how to extract and encode the data collected from the reader or keypad.
- [Understanding Reader LED Profiles](#): define the LED states on a reader interface for a Gateway or Reader module.



Note

---

See also the [“Configuring Badge Templates” section on page 9-25](#). Badge templates define common settings for badge types. In the personnel record, select the badge template to quickly populate the badge fields, and then make additional changes, if necessary.

---

## Impact of Template Changes on Configured Doors and Devices

- Changes to a gateway template do not impact configured controllers. Only new controller configurations include the new settings. Gateway templates assist in new configurations only.
- Door configurations are impacted whenever the template settings for that door are changed, unless you enter a custom setting for that door.
- Changes to a door or device configuration, including changes to a template, do not take effect until the configuration is applied to the effected Gateways.



### Tip

The names of all hardware elements are editable, including drivers, controllers, expansion modules, and door devices.

- Each template type includes a set of default templates. Most attributes for these default templates cannot be changed in the template. They can only be changed for an individual device. Only user-created templates can be modified.

## Gateway Templates

Gateway templates include pre-defined sets of expansion modules and other devices, and basic attributes such as the time zone. To create a gateway template, save the template from a previously configured device, as described in [Creating Custom Gateway Configurations without Templates, page 6-2](#)

Gateway templates are used when configuring a new controller in the Hardware Tree module. For instructions to use gateway templates, see [Configuring Gateways Using Existing Templates, page 6-7](#).



### Tip

To create an exact copy of a gateway configuration for a single controller, see [Cloning a Gateway Configuration, page 6-53](#).

## Controller Templates

Identiv EM-100 controller templates enable the system configurator to pre-define the door and device attributes to include in a new controller. To create a controller template, save the template from a previously configured device, as described in [Creating Custom EM-100 Controller Configurations without Templates, page 6-15](#).

Controller templates are used when configuring a new controller in the Hardware Tree module. For instructions on how to use controller templates, see [Configuring EM-100 Controllers Using Existing Templates, page 6-18](#).

## Understanding Door Templates

Door template specify the following:

- The number and types of devices that belong to the door using this door template.
- The default properties of the door. These default properties can be overridden in the door configuration.

Door templates are assigned to a controller using one of the following methods:

- [Configuring Gateways Using Existing Templates, page 6-7](#)

- [Adding Doors Using Door Templates, page 7-3](#)

For example, use the Hardware Tree module device view to configure a controller and then assign one or more door configurations to the controller. The door configurations are defined using templates.

If the basic controller configuration was entered using a Discovered configuration, use the Locations view to define doors using door templates or assign a door template to the door.

**Tip**

---

You can also override a template setting for a specific door or device without effecting other doors or the template settings.

---

To create and modify door templates, see [Chapter 8, “Configuring Door and Device Templates”](#).

## Understanding Device Templates

Device templates operate on the same concept as door templates, allowing you to create common configurations for devices, such as locks and readers.

For example, a typical access control solution might use one or two types of locks in multiple locations, with each lock type using a similar configuration. Or, the locks may use different configurations in different locations. In either case, instead of creating separate configurations for every lock in the system, you can create a device template for each type of lock that uses a similar configuration.

Device templates are applied to a specific controller interface, or used to define the devices in door templates. If a device requires a different configuration, you can easily override the settings for a specific device without effecting the other devices or the template.

**Tip**

---

ICPAM includes sample templates, or you can create new templates. There is no limit to the number of templates in a system.

---

Changes to a door configuration or device, including changes to a template, do not take effect until the configuration is downloaded to the effected Gateways.

**Related Documentation**

- [Chapter 6, “Configuring Controllers”](#)
- [Chapter 7, “Configuring Doors”](#)
- [Chapter 8, “Configuring Door and Device Templates”](#)

## Understanding Virtual Credential Templates

When an access control card is presented to a reader, the reader reads a set of bits. The reader needs to know how to interpret the bits, how to validate the data, and how to extract relevant card information. Virtual Credential Templates specify the card data format for a reader, and are used to configure reader device templates.

**Note**

---

The virtual credential template can be used for either gateway credentials or Identiv EM-100 controller credentials.

---

The data specification include the following:

- Card data fields and data range
- Parity bits and their bit position for data validation
- Marker bits and their bit positions/range using sentinels

Each credential template has primary and secondary data fields to determine how the card data is extracted.

See [Creating a Virtual Credential Template, page 8-20](#) for more information.

## Understanding Gateway Credential Templates

Gateway Credential Templates specify the card data format for a reader connected to a gateway, and are used to configure reader device templates associated with that reader.



**Note**

---

The gateway credential template is used for gateway credentials only. If this template is for both gateway and controller use, use the Virtual Credential Template instead.

---

The data specification include the following:

- Card data fields and data range
- Parity bits and their bit position for data validation
- Marker bits and their bit positions/range using sentinels

Each credential template has primary and secondary data fields to determine how the card data is extracted.

See [Creating a Gateway Credential Template, page 8-18](#) for more information.

## Understanding Reader LED Profiles

Use the **Reader LED** module to create settings for LED lights on the reader interface of a Gateway or Reader module. The profiles are applied to reader interfaces in the Hardware Tree module, or to door templates. See [Configuring Reader LED Profiles, page 8-24](#) for more information.

# Understanding Door Modes, Door Schedules, and the First Unlock Feature

- [Overview, page 5-29](#)
- [Understanding Door Modes, page 5-30](#)
- [Viewing the Door Mode Status, page 5-31](#)
- [Understanding the Default Door Mode, page 5-31](#)
- [Understanding the Scheduled Door Mode, page 5-31](#)
- [Understanding First Unlock Impact on the Scheduled Mode, page 5-32](#)
- [Manually Override the Door Mode Using Commands, page 5-32](#)
- [Impact of Controller Reset on the Default and Scheduled Modes, page 5-34](#)



- [Understanding Door Schedule Entries in ICPAM 2.1, page 5-35](#)
- [Configuring the Default and Scheduled Door Modes, page 5-36](#)

## Overview

Each door configuration has a default mode that defines if the door is locked, unlocked, secured, or left open. The door remains in this mode at all times unless you configure an optional schedule to define exceptions to the default mode. For example, if the default mode for a door is Lock, and you define a door schedule that automatically unlocks the door between 8 am and 5 pm. (Close), then the door will be locked at all hours except 8 am to 5 pm.

In addition, the First Unlock feature ensures that the door schedule (and associated mode) is activated only if a user successfully swipes a badge to access the door. This is useful in situations such as a snow day, when employees may not be able to reach work. The door is not automatically unlocked unless a badge holder is physically present.

To configure door modes and door schedules, use the door Properties window shown in [Figure 5-19](#).

**Figure 5-19** Door Properties Window

The screenshot shows the 'Edit - Door' Properties window. The left sidebar contains a tree view with the following items: General, Location, Associate Devices, Properties (selected), Usage Profiles, Facility Code, Duress Specifications, and Door Groups. The main area is titled 'Properties' and contains a list of settings, each with a 'Default' checkbox on the right. A green box highlights the following settings:

Setting	Value	Default
Scheduled door mode:	Close	<input checked="" type="checkbox"/>
Door enable schedule:	TRAINING LUNCH DOOR SCHEDULE	<input checked="" type="checkbox"/>
First unlock:	<input type="radio"/> Yes <input checked="" type="radio"/> No	<input checked="" type="checkbox"/>
Default mode:	Lock	<input checked="" type="checkbox"/>

Other settings visible in the window include:

- Relock time interval (sec): 5
- Door held open time (sec): 10
- Door lock on close:  Yes  No
- Deadbolt engage delay (sec):
- If badge not in gateway: Use Server
- Access decision on timeout: Deny
- If server unreachable: Deny
- Server access timeout (sec): 15
- If server unreachable (APB): Deny
- ADA time interval multiplier: 2
- Door swing activation delay(sec):
- Door swing usage:
- Generic reader:
- Multifactor authentication timer(sec): 10
- Toggle door mode:  Yes  No
- Door Sensor Timer (sec):

The door Properties window includes the following four fields:

- **Default mode:** the default mode of the door. The door remains in this mode at all times except when a schedule is defined. See [Understanding the Default Door Mode, page 5-31](#).
- The **Door enable schedule:** specifies a door schedule for the times and days when a different door mode is applied. If you select a schedule, the schedule will override the default mode for the times and days defined in the schedule. See [Understanding the Scheduled Door Mode, page 5-31](#).
- **Scheduled door mode:** the mode used when the door scheduled is applied.
- **First unlock.** determines if the schedule is activated only after the first successful badge swipe. The door remains in default mode until a badge is used to access the door, even after the beginning time for the schedule. See [Understanding First Unlock Impact on the Scheduled Mode, page 5-32](#)



**Tip**

See [Configuring the Default and Scheduled Door Modes, page 5-36](#) to create a schedule and apply it to a door. See also Step 6 in [Configuring Door Templates, page 8-2](#).

## Understanding Door Modes

A door can be in one of four door modes:

- *Open:* the door is held open and the lock is in unlocked state.
- *Close:* the door is physically closed and the lock is in unlocked state.
- *Lock:* the door is physically closed and the lock is in locked state.
- *Secure:* the door is locked and the dead bolt is applied.

The *Default* mode defines the door mode at all times unless overridden by a door schedule or door mode command. See [Understanding the Default Door Mode, page 5-31](#).

A *Scheduled* mode overrides the default mode for the days and hours in a door schedule. For example, if the default mode is Lock, you can create a door schedule to change the mode to Close during normal business hours. The door will be locked at all times except 8 am to 5 pm, when it is physically closed but unlocked. See [Understanding the Scheduled Door Mode, page 5-31](#)

The *Override* mode occurs when you manually change the door mode using a door command. The Override door commands are:

- **Set Door Mode Lock**
- **Set Door Mode Open**
- **Set Door Mode Secure**
- **Reset Door Mode** (removes the override and restores the default or scheduled mode)

If you manually override the door mode using a command, the door remains in that mode until you select another door mode command or reset the controller. For more information, see [Manually Override the Door Mode Using Commands, page 5-32](#).

## Viewing the Door Mode Status

The door mode is displayed in the Extended Status pane when you select a door in the Hardware Tree or Door/Location-based Hardware module. In the example shown in [Figure 5-20](#), a door's Default mode is *Open* and the Current mode is *Close (Scheduled)*. This means that the door is currently in the scheduled mode of Close, but when the schedule ends, the door will return to the default mode of Open.

[Figure 5-20](#) also shows the door mode commands used to override the Current and Default mode. In this example, if the user selects the command **Set Door Mode Lock**, the door will stay in Lock mode until another door mode command is selected, or the controller is reset. For more information, see [Manually Override the Door Mode Using Commands](#), page 5-32 and [Impact of Controller Reset on the Default and Scheduled Modes](#), page 5-34.

**Figure 5-20** Door Mode Commands and Status

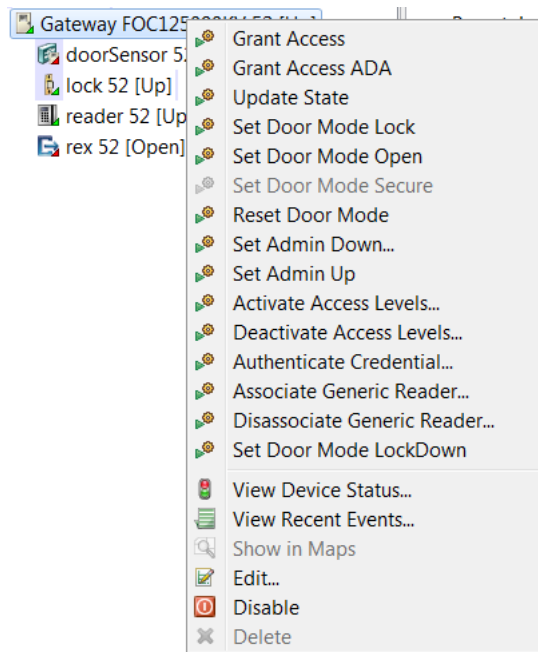

## Understanding the Default Door Mode

The default door mode is the state of the door at all times, except when an optional schedule is applied. For example, if the default mode is Lock, the door is physically closed and the lock is applied at all times. You can override the Default door mode using a door schedule, or by selecting a door command.

## Understanding the Scheduled Door Mode

Door schedules define exceptions to the default door mode during specific days and times. For example, if the default door mode is Secure, the door will be in secure mode at all times except during the days and hours defined by a door schedule. To create and apply a door schedule, do the following:

1. Create the schedule using the Schedule Manager.
2. Select the schedule in the door Properties window using the **Door Enable Schedule** menu.

3. Select the door mode used during the schedule using the **Scheduled door mode** menu.

Door schedules are optional: if a door schedule is not configured, the door remains in Default mode at all times. See [Configuring the Default and Scheduled Door Modes, page 5-36](#) for instructions to create a schedule and apply it to a door.

Door schedules change the door mode at the days and times included in the schedule. If a door is set to open every workday at 8 am, the door opens even if it is a holiday and no one is physically present. See [Understanding First Unlock Impact on the Scheduled Mode, page 5-32](#) to avoid this situation.

To override a door schedule, see [Manually Override the Door Mode Using Commands, page 5-32](#).

## Understanding First Unlock Impact on the Scheduled Mode

First Unlock ensures that the door schedule (and associated mode) is activated only if a user successfully swipes a badge to access the door. This is useful in situations such as a snow day, when employees may not be able to reach work. The door is not automatically unlocked unless a badge holder is physically present. When the door is accessed with a valid badge, the door schedule is activated and the Scheduled Door Mode is applied. See [Configuring the Default and Scheduled Door Modes, page 5-36](#) for instructions to apply the First Unlock option.

### Door Mode Changes and First Unlock

A badge is required to activate the door schedule (and associated mode) anytime the door mode is reset, after the controller is reset, or after a power failure to the controller.

### Applying First Unlock

The First Unlock feature is applied immediately when a door configuration is changed. For example, if a ICPAM administrator changes a door configuration at 10 am to include First Unlock, the change is applied immediately and the door returns to Default mode until accessed with a badge to activate the scheduled mode.

For additional information on operating doors that are configured with First Unlock, see the following:

- [Manually Override the Door Mode Using Commands, page 5-32](#)
- [Impact of Controller Reset on the Default and Scheduled Modes, page 5-34](#)

## Manually Override the Door Mode Using Commands

When the door mode is manually changed using a door command, the current mode is displayed as *Override*. Door remain in the *Override* mode until another door command is selected, or the controller is reset.

For example, in [Figure 5-21](#) the current mode is Close (Scheduled). Right click the door and select **Set Door Mode Lock**. The current mode is changed to Lock (Override), as shown in [Figure 5-22 on page 5-34](#). When a door in the override mode door schedules do not take affect, the door will remain in the manually assigned mode and will not resume scheduled operations until the door mode is manually reset.

**Figure 5-21**      *Selecting a Door Mode Command*

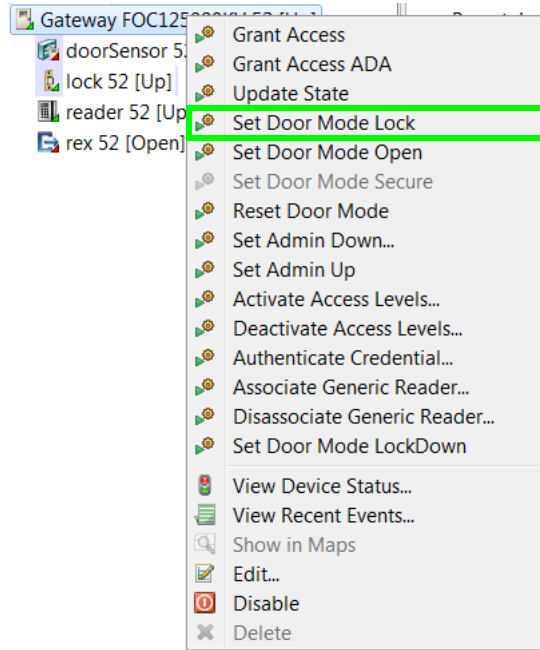

The current mode remains Lock (Override) until you do one of the following:

- Select another door mode command. For example, **Set Door Mode Open**.
- Select the **Reset Door Mode** command to remove the override and restore the configured default and scheduled modes. If a door schedule is configured, and the time is within the schedule, the door enters the scheduled mode immediately (however, if First Unlock is configured, the scheduled mode is not activated until the door is accessed with a badge).
- Reset the controller, as described in [Impact of Controller Reset on the Default and Scheduled Modes, page 5-34](#). Resetting the controller has the same affect as the **Reset Door Mode** command.

For example, in [Figure 5-22](#) the current door mode is Lock (Override). The door stays in the override mode until you select another door mode or reset the controller. In this example, the **Reset Door Mode** command is selected, which returns the door to the scheduled mode. However, since the First Unlock feature is configured, the door stays in Default mode (Open) until the door is accessed with a valid badge.

Figure 5-22 Reset Door Modes Command

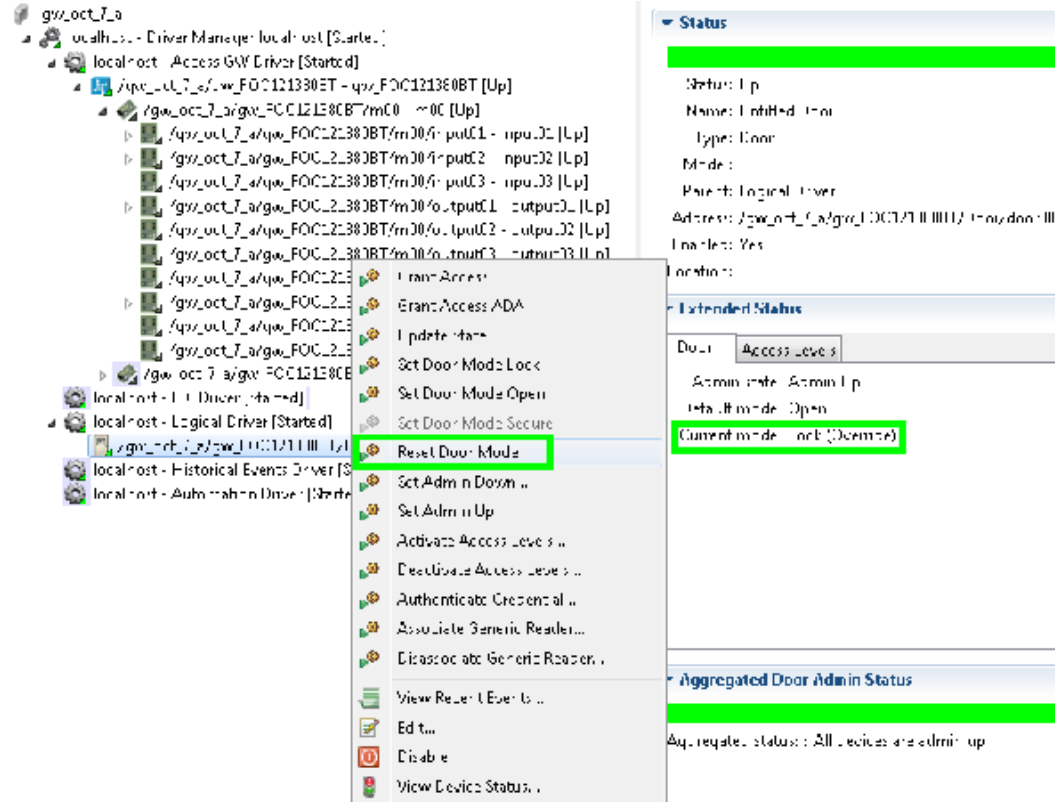

## Impact of Controller Reset on the Default and Scheduled Modes

When a controller is reset, the default mode, door schedule, and First Unlock rule are reapplied. This has the same affect as invoking the **Reset Door Mode** command, as described in [Manually Override the Door Mode Using Commands](#).

The controller is reset using the **Reset Gateway** command, or when the controller power is turned off and on.

### Example 1

- The default door mode is **Lock** (physically closed and locked).
- The scheduled door mode from 8 am to noon is **Close** (physically closed and unlocked).
- First Unlock is set to **Yes**.

If power to the controller goes off and comes back on at 9 am (during the scheduled mode), the controller is reset. Since First Unlock is configured, and the door returns to the default state (Lock) until a badge is swiped to reactive the scheduled door mode (Close).

### Example 2

- The default door mode is **Lock** (physically closed and locked).
- The scheduled door mode from 8 am to 5 pm is **Close** (physically closed and unlocked).

- At 3 pm, the guard manually sets the door to Lock mode and goes to break (see [Manually Override the Door Mode Using Commands](#), page 5-32).
- First Unlock is set to **No**.

While the guard is away, another user invokes the Reset Gateway command in ICPAM. Since the First Unlock feature is not configured, the scheduled mode is immediately applied and the door is placed in **Close** (physically closed and unlocked). The door is now unlocked even though the guard is absent.

## Understanding Door Schedule Entries in ICPAM 2.1

The Door Schedule is evaluated to determine the state of a given door at any point of time. A door can be in any one of the four states:

- Door Open
- Close
- Lock
- Secure

The current state of a door is determined by two door properties namely the Default mode and the Scheduled mode. The default mode and the scheduled mode are configured for each door using ICPAM. Both default mode and scheduled mode can be configured to any one of the four door states. When you set the current state of door to the default mode, it automatically carries a ‘Deny access’ command and in schedule mode it carries a ‘Permit access’ command.

At any given time, the current door state (i.e. when the door is idle and not being used by any user) is determined by its door schedule which in turn depends on the default mode or the scheduled mode. The door schedule consists of one or more schedule entries. Every 45 seconds, for each door, the controller runs through each door’s schedule entries to determine the current door state of each door.

The current door state is determined as follows:

- If the current time is outside the time range defined by its door schedule entries, then the current state of the door is set to default mode.
- If the current time matches or falls under any one of the door schedule entry’s time ranges, then the door’s current state is set to either scheduled mode or default mode. If the schedule entry’s action is scheduled mode, then current state of the door is set to scheduled mode and if the schedule entry’s action is default mode, then the current door state is set to default mode.
- When the current time matches more than one schedule entry of a given door schedule then the action taken is determined as follows:
  - If there is any schedule entry set to default mode, then this action takes over the schedule entries that are set to schedule mode.

Starting with the ICPAM 2.1 release, when the current time matches more than one schedule entry of a given door schedule then the action taken is determined as follows:

- The order of the door schedule entries is taken into account and the first matching schedule entry’s action is taken.

For example, if the first matching schedule entry’s action is set to default mode, the current door state is set to default mode. If the first matching schedule entry’s action is set to scheduled mode, the current door state is set to scheduled mode. If there are no matching entries, the current door state is set to default mode.

## Configuring the Default and Scheduled Door Modes

In the following example, a door schedule is created for a lobby door. The door should be physically closed but unlocked and open to the public during normal working hours, from 8 am to 5 pm. However, the door should be also be locked from 12 noon until 1 pm when the receptionist is at lunch.

Since this location occasionally suffers snow storms that close roads and delay traffic, we want to keep the door locked in the morning until the receptionist (or another employee) arrives and accesses the door with a badge, even if they arrive after the scheduled unlock time of 8 am. (the door should not automatically unlock for public access at 8 am, even if there is no employee on-site). This First Unlock rule is also applied to the lunch hour, so the door remains locked at 1 pm until the receptionist or another badge holder physically accessed the door.



**Note**

The following sample schedule does not include exceptions for holidays or other special cases. For complete instructions to configure door schedules, see [Using the Schedule Manager, page 11-9](#).

**Step 1** Create a schedule for the door.

**Note** Create door schedules that define the times the door is not in default mode.

- a. Select **Schedules** from the **Schedule Manager** submenu under the **Doors** menu.

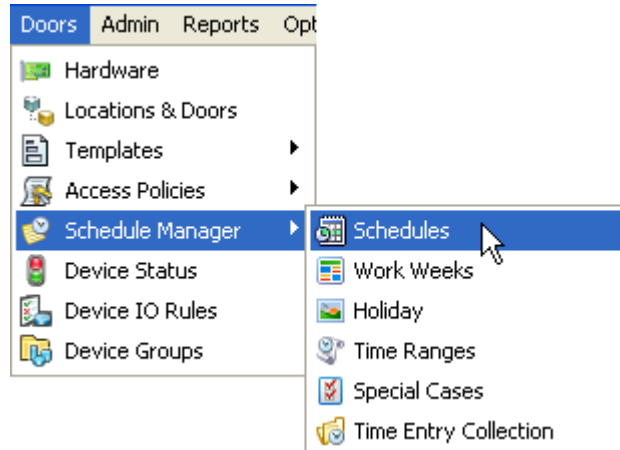

The Schedules list appears, like in this example:

Name	Description	Type	Creation Date	Location
Always Deny	Always Deny Schedule Description	Access Policy	7/15/2015 14:18:24	
Always Permit	Always Permit Schedule Description	Access Policy	7/15/2015 14:18:24	
Default Schedule	All working days 8AM to 6PM sched...	Access Policy	7/15/2015 14:18:24	
Identiv Work Day Schedule	Access to perimeter doors Santa An...	Access Policy	8/21/2015 13:03:25	Identiv
Santa Ana Facility Access Policy	General Access M-F 8-5 pm	Access Policy	8/21/2015 13:05:28	Identiv
TRAINING LUNCH DOOR SCHEDULE	LUNCH UNLOCK OF CLASSROOM	Door Policy	8/21/2015 13:42:54	Identiv

Alarms: 5 active | 6 items | cpamadmin - SantaAnaCR



b. Click **Add...**

The screenshot shows the 'Add - Schedules' dialog box with the following fields and values:

- Name: Always Deny
- Schedule type: Access Policy
- Hierarchical location: (empty)
- Description: Always Deny Schedule Description
- Type: (empty)
- Values: (empty)
- Action: Deny
- Time range: (empty)

At the bottom, there is a table with the following data:

Type	Values	Time Ranges	Action
Week Groups	All Days Work Week	Always Time Range Gr...	Deny

- Enter the Name and Description for the schedule.
- For **Schedule Type** select **Door Policy** (only door policy schedules appear in door configurations).
- For **Type**, select **Work Weeks**. From the **Values** menu, select **Default Work Weeks** (Monday - Friday)
- For **Action**, select **Use Schedule Mode**. Create a custom **Time Range** for the schedule (for example: “8-5, minus lunch”):

The screenshot shows the 'Edit - Time Ranges' dialog box with the following fields and values:

- Name: Default Time Range Group
- Hierarchical location: (empty)
- Description: 8AM To 6PM Time Range Group
- Start time: 08:00:00
- End time: 18:00:00

- For **Time Ranges** click **New**.
  - In the Time Ranges window, enter a **Name** and **Description** for the time range.
  - Enter a start time of 8:00 and end time of 12:00, and click **Add** to add the entry in the list box.
  - Enter a start time of 13:00 (1 pm) and an end time of 17:00 (5 pm), and click **Add**.
  - Click **Save and Close**.
- In the Add Schedule window, select the new range (**8-5, minus lunch**) from the **Time Range** menu.

- h. Click **Add** to add the schedule to the list.
- i. Click **Save and Close** to create the door schedule. The door schedule appears in the Schedules window.



**Tip** The schedule is not active until you apply it to a door, as described in the following steps.

- Step 2** Open the door configuration Properties window.
- a. Select **Hardware Tree** or **Door/Location-based Hardware** from the **Doors** menu.
  - b. Double click an existing door icon to open the door edit window.
  - c. Select **Properties**.



**Tip** To create or modify a door template with these settings, select **Door Templates** from the Doors menu, in the Templates submenu. See [Configuring Door Templates, page 8-2](#).

- Step 3** Apply the door mode and schedule settings.

The following example places the door in Lock mode at all times, except for Monday to Friday, 8 am to 12 pm, and 1 pm to 5 pm, when the door is in Close mode.

**Tip**

To override the default template settings, uncheck the box in the right column to activate the field.

- a. For **Default mode**, select **Lock**. The door is physically closed and the lock applied at all hours by default. A badge is required for access.

Scheduled door mode:	Close	<input type="checkbox"/>
Door enable schedule:	Door Schedule,8-5,minus lunch	<input type="checkbox"/>
First unlock:	<input checked="" type="radio"/> Yes <input type="radio"/> No	<input type="checkbox"/>
Default mode:	Lock	<input checked="" type="checkbox"/>

- b. For **Door enable schedule**, select **8-5, minus lunch**. This is the schedule created in [Step 1](#).
- c. For **Scheduled door mode**, select **Close**. The door is physically closed during the door schedule hours, but the lock is not applied.
- d. For **First Unlock**, select **Yes**. The door remains in Lock mode in the morning and after lunch break until a badge holder physically swipes their badge to activate the schedule and place the door in Close mode.
- e. Click **Save and Close** to save the changes.

**Step 4** Apply the door configuration changes.

Right-click a location or controller and select **Apply Configuration Changes**.

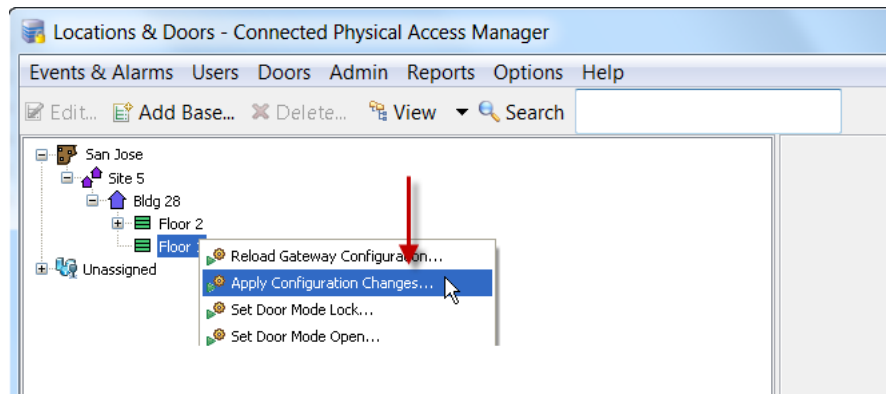

**Note** Controllers must be in the Up state, signified by a green triangle in the icon. A dark green triangle means there are configuration changes that have not been applied.

# Locating Serial Numbers

- [Locating Controller and Expansion Module Serial Numbers](#)
- [Displaying the ICPAM Appliance Serial Number](#)

## Locating Controller and Expansion Module Serial Numbers

Serial numbers for the controller and other expansion modules are available at the following locations:

- Printed on the back label of the module case.
- Listed in the **Show Inventory** screen of the controller administration tool (direct PC connection). See the *Cisco Physical Access Gateway User Guide* for more information.
- Listed in the ICPAM Controller properties. Open the Hardware Tree module device view, right-click on the module, select **Edit** and then **Properties**.

## Displaying the ICPAM Appliance Serial Number

To view the appliance serial number, do the following:

- 
- Step 1** Log on to the ICPAM Server Administration utility:
- For a direct connection, see [Configuring ICPAM on a Virtual Machine \(VM\), page 2-17](#).
  - For an Internet connection, open a web browser and enter the IP address used for the ICPAM Server Administration utility. See [Logging on to the ICPAM Server Administration Utility, page 2-2](#), or ask your system administrator for assistance.



---

**Note** The administration screens also appear immediately following the initial setup.

---

- Step 2** Select the Monitoring tab, and then select Status, as shown in [Figure 5-23](#).
- Step 3** Refer to the entry for Serial Number.

Figure 5-23 ICPAM Appliance Serial Number

The screenshot shows the 'Monitoring > Status' page of the Identiv Connected PAM Server Administration interface. The page is titled 'Identiv Connected PAM Server Administration' and includes a navigation menu with 'Monitoring', 'Setup', 'Commands', 'Launch Identiv Client', and 'Downloads'. The 'Monitoring > Status' section is active, displaying server and service status information.

**Server Status:**

Admin State:	Up	<input type="button" value="Stop"/>
Server Mode:	Active	
Version:	2.0.0	
Serial Number:	000C-29200851	
High Availability Audit:	disabled	

**Services Status:**

TFTP Service	Up	<input type="button" value="Stop"/>
Web Service API	Enabled	<input type="button" value="Disable"/>

The 'Serial Number' field is highlighted in green. A 'Cisco Compatible' logo is visible in the bottom right corner of the interface. The footer contains the text: 'Copyright © 2015 Identiv, Inc. | All Rights Reserved.'

### Related Documentation

- [Chapter 7, “Configuring Doors”](#)
- [Chapter 8, “Configuring Door and Device Templates”](#).
- To install Gateways and expansion modules, see the *Cisco Physical Access Gateway User Guide*.



# Configuring Controllers

---

This chapter provides instructions on how to add and modify controller configurations. In addition, it details how to clone, replace, and delete controllers, as well as change Gateway passwords and modify driver configurations.



Tip

---

You can create the door configuration before the related Gateway is physically installed and added to the network. See [Provisioned \(Pre-Populated\) vs. Discovered Controller Configurations, page 5-2](#) for more information.

---

## Contents summary

- [Configuring New Controllers, page 6-1](#)
- [Modifying Existing Controllers, page 6-42](#)
- [Applying Configuration Changes, page 6-50](#)
- [Cloning a Gateway Configuration, page 6-53](#)
- [Replacing a Gateway, page 6-54](#)
- [Deleting a Controller, page 6-55](#)
- [Changing Gateway Passwords, page 6-55](#)
- [Modifying Driver Configurations, page 6-58](#)
- [Controller and Driver Commands, page 6-68](#)

## Configuring New Controllers

You can add a new controller, with or without using templates, as explained in the following sections:

- [Creating Custom Gateway Configurations without Templates, page 6-2](#)
- [Configuring Gateways Using Existing Templates, page 6-7](#)
- [Creating Custom EM-100 Controller Configurations without Templates, page 6-15](#)
- [Configuring EM-100 Controllers Using Existing Templates, page 6-18](#)

## Creating Custom Gateway Configurations without Templates

To create a door, a gateway configuration must first be created that defines the modules and devices attached to the gateway. There are essentially two ways of doing this:

- Create a gateway from scratch
- Create a gateway using an existing gateway template

### Procedure

Complete the following instructions to create a custom gateway configuration without using an existing gateway template, and then save it as a template. You can also clone the configuration for use with another gateway.

**Step 1** Open the Hardware Tree module in the Device view.

- Select **Hardware Tree** from the **Doors** menu.
- Select **Device** from the **View** menu.

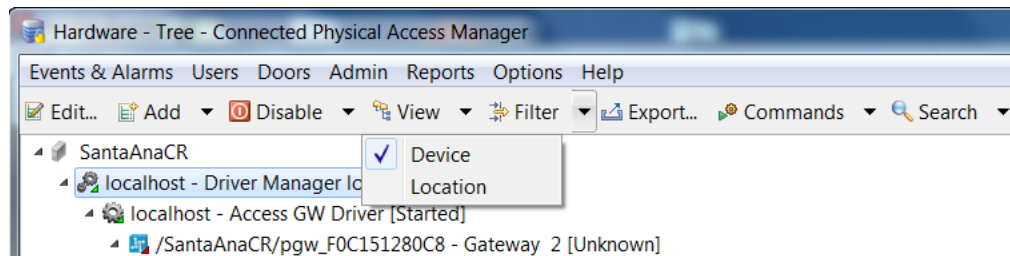

**Tip** See also [Viewing Doors and Devices in the Hardware Tree View, page 5-4](#).

**Step 2** Add a Gateway controller.

Right-click on the **Access GW Driver**, and choose the **New Gateway Controller** command from the pop-up menu.

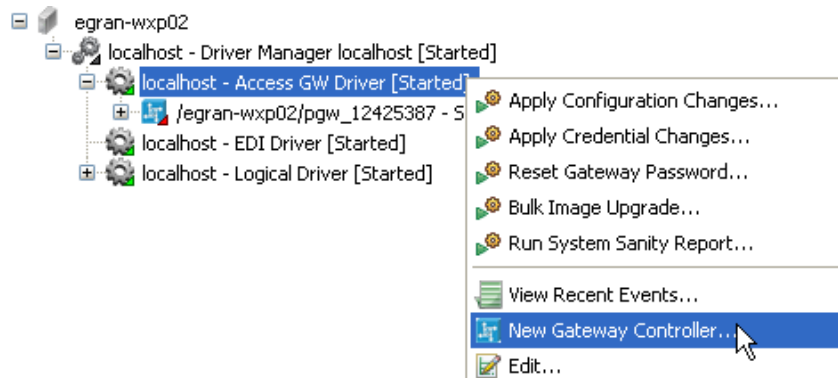



**Step 3** In the resulting dialog, select **No** to configure the Gateway without using a template, and click **Next**.

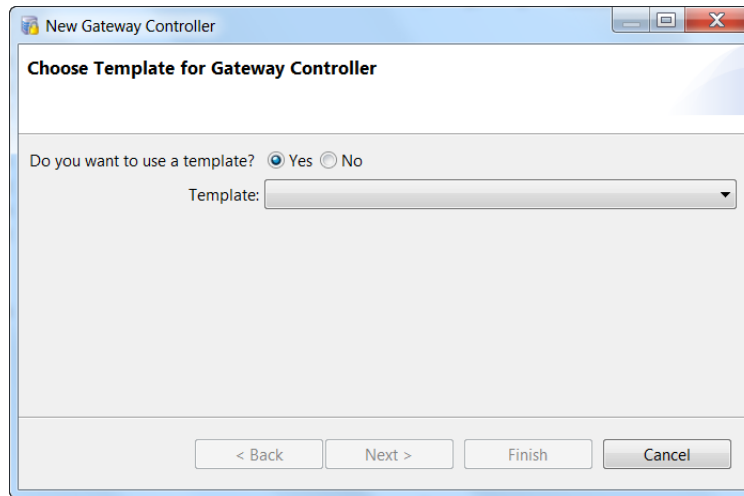

**Step 4** In the resulting dialog, specify the Gateway's basic properties.

- a. **Name:** enter a descriptive name to identify the controller.
- b. **Serial Number:** enter the serial number. See [Locating Serial Numbers](#), page 5-40.
- c. **Location:** the assigned location of the module. See [Creating the Location Map](#), page 5-8.
- d. **Time Zone:** select the time zone for your system.
- e. **Daylight Savings:** select **True** if Daylight Savings time is observed.
- f. To add additional expansion modules, click **Next**.

or

To create the Gateway controller (the default module) without adding additional modules, click **Finish**.

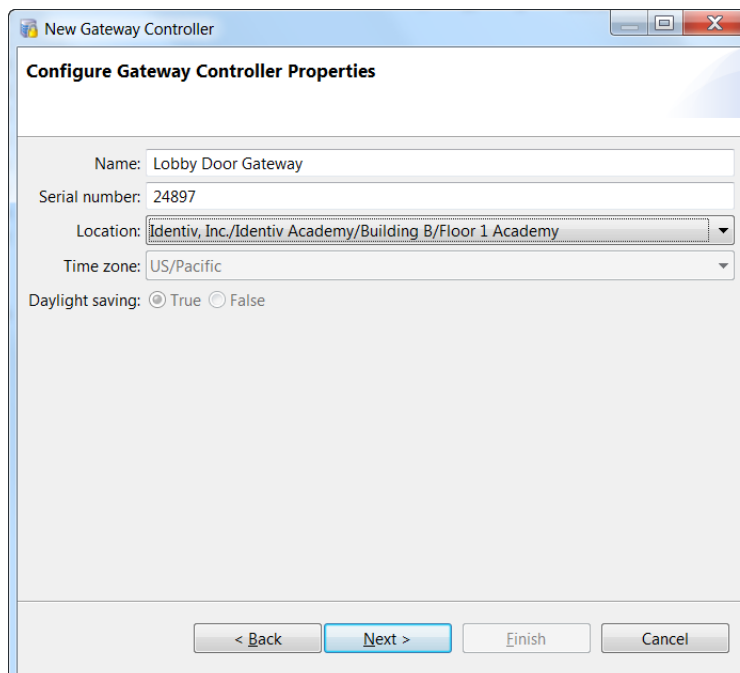

**Step 5** (Optional) Specify the expansion modules that are attached to the Gateway.



**Note** This step is only required if expansion modules are installed. If additional modules are not installed, click **Finish**.



**Note** The default module is the Gateway.

- a. **Name:** enter a descriptive name to identify the controller.
- a. **Serial Number:** enter the serial number. See [Locating Serial Numbers, page 5-40](#).
- b. **Module Type:** select Reader, Input, or Output.
- c. **Reader Connection Mode:** (Reader modules only) select if the device supports one or two reader connections.
- d. Click **Add**. The expansion module is added to the list.
- e. Repeat these steps for each additional module.
- f. Click **Finish** to save the changes and close the window.

**Add Additional Modules**

Name:

Serial number:

Module type:

Reader connection mode:

Name	Serial Num...	Module Type	Reader Con...	Module Nu...
m00	24897	Default Mo...	One Reader	m00



**Tip** To modify the module list, select a module and click **Edit** or **Remove**.

**Step 6** (Optional) Add devices to the Gateway or expansion module interfaces.

**Note** Devices are usually added when configuring a door. See [Chapter 7, “Configuring Doors”](#).

- a. Expand the hardware tree to view the Gateway or expansion module interfaces.

- b. Right-click an interface and select a device for the interface. For example: **New REX**.

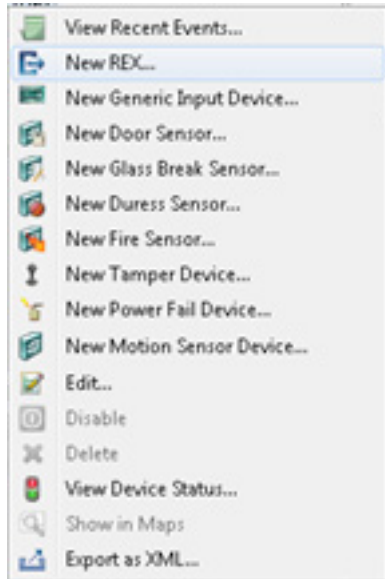

- c. In the device window, select **REX** and enter the device settings.
- Select a **Template name** to populate the fields.
  - To override the template settings, deselect the **Default** check box next to each field.
  - To restore the default template setting, re-select the **Default** check box.
  - On the REX page, enter the **Debounce Timer(ms)** value.
- d. Click **Save and Close**.

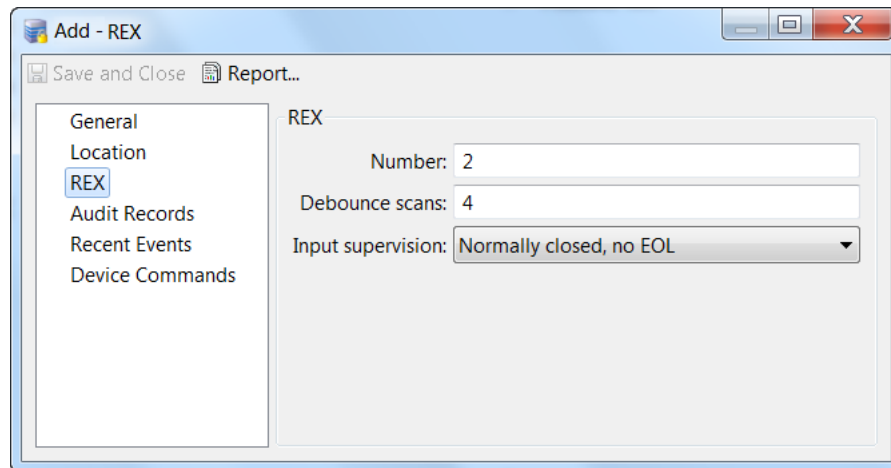

- e. Repeat these steps for each device connected to the Gateway.

**Step 7** Apply the configuration changes to download the new settings to the devices.

- To update all Gateways: right-click the **Access GW Driver** and select **Apply Configuration Changes**.

- To update a single Gateway: right-click the Gateway and select **Apply Configuration Changes**.

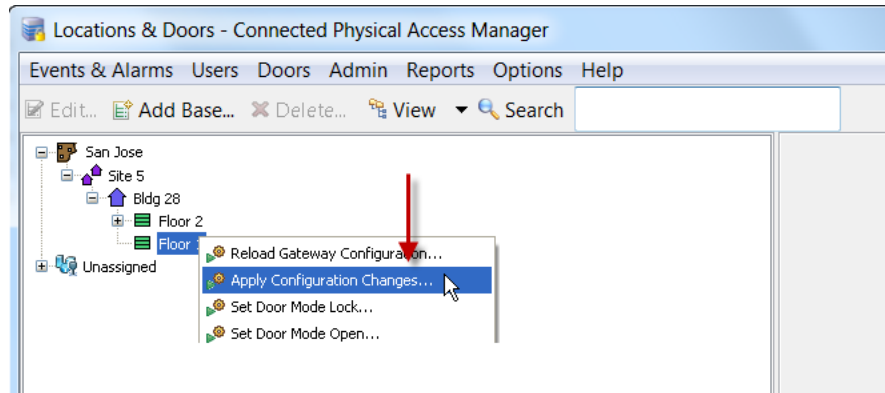

**Note** Gateways must be in the Up state, signified by a green triangle in the icon. A dark green triangle means there are configuration changes that have not been applied. For more information, see [Applying Configuration Changes, page 7-14](#).

**Step 8** (Optional) Create a Gateway template from the new configuration.

- Right-click on the required Gateway controller and select **Save As Gateway Template**. Enter a name for the template and click **OK**. The new template is displayed in the main Gateway templates window (see [Figure 6-2](#)).

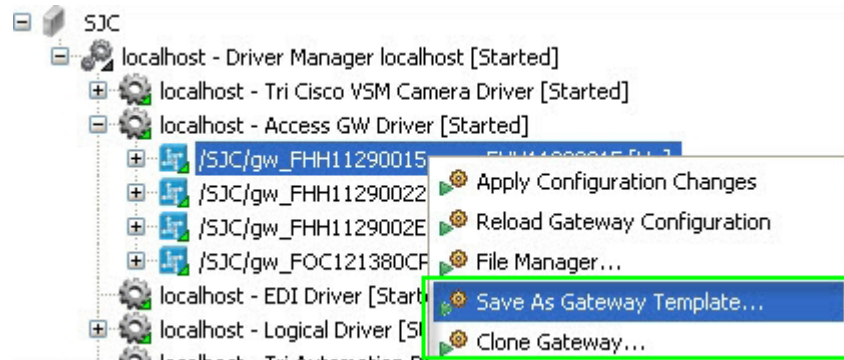

- Select **Clone Gateway** to create an exact copy of a Gateway's configuration for a single Gateway. See [Cloning a Gateway Configuration, page 6-53](#).

- Step 9** (Optional) Add the door configuration that uses the ports on the Gateway. See [Adding New Doors](#), page 7-2.

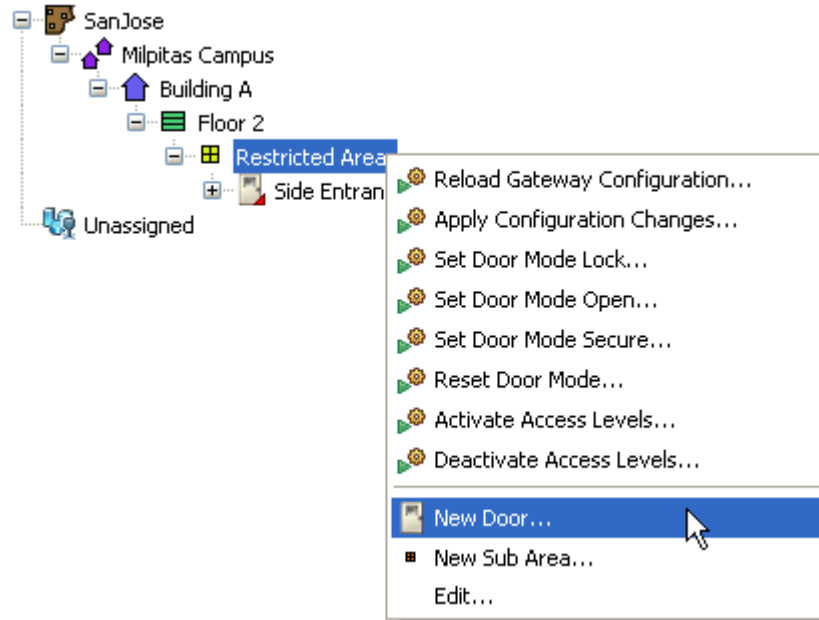

## Configuring Gateways Using Existing Templates

Use Gateway templates to quickly add a new Gateway configuration. After the Gateway has been added to the system, you can configure one or two door configurations.

To view the existing templates, select **Doors > Templates > Gateway Templates** from the menu bar.

*Figure 6-1 Gateway Templates command*

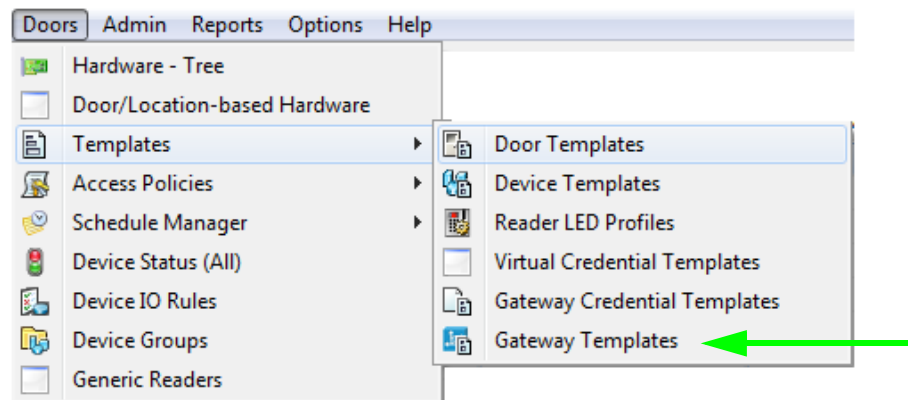
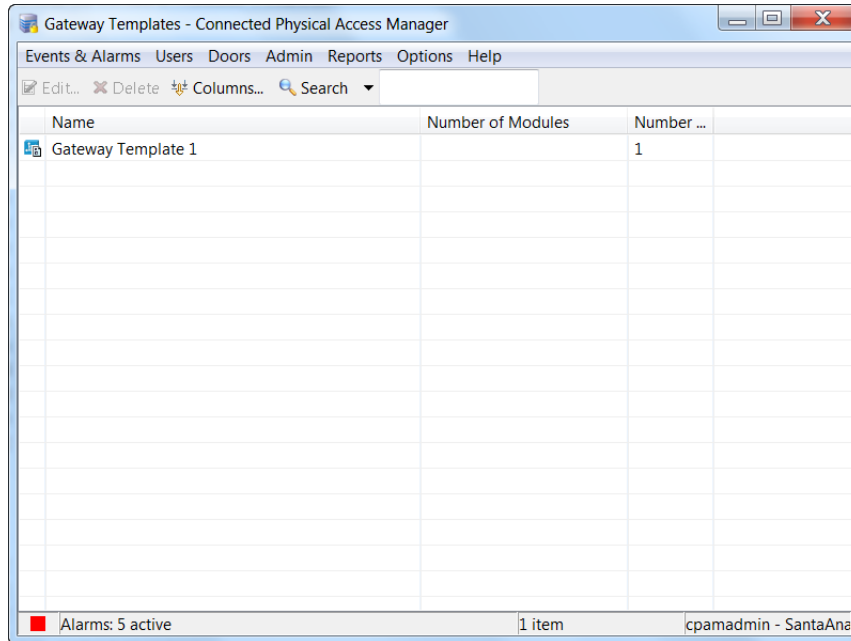

Figure 6-2 shows the main window. The default Gateway templates cannot be changed. Only user-created templates can be modified.

Figure 6-2 Gateway Templates main window



If the template you need is displayed in the **Gateway Templates** window, you can use the following procedure to add a gateway to the system.

To create a gateway using a Gateway template, use the following procedure.

- Step 1** Create the locations for door and devices.
- Select **Door/Location-based Hardware** from the **Doors** menu.
  - To create a new site, click **Add Base**.
  - To create a sub-location, right-click a location and select **New [Element]**.
  - To change the properties for an element, right-click a location and select **Edit**.

If this has already been done, proceed to Step 2.



**Tip** You can create any combination of location elements. Door configurations can be assigned to any level of the hierarchical tree.

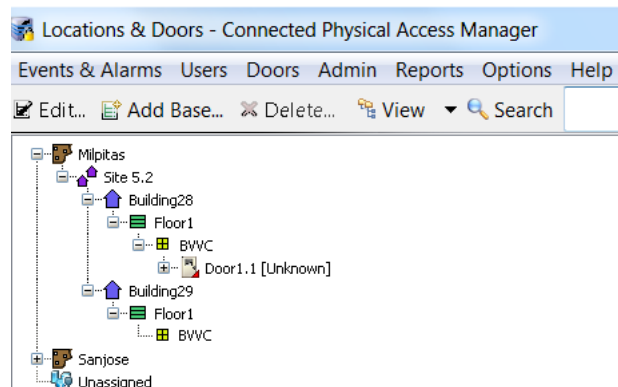

**Step 2** Open the Hardware Tree module.

- a. Select **Hardware - Tree** from the **Doors** menu.
- b. Select **Device** from the **View** menu, if necessary.

**Note** See [Viewing Doors and Devices in the Hardware Tree View, page 5-4](#) for more information.

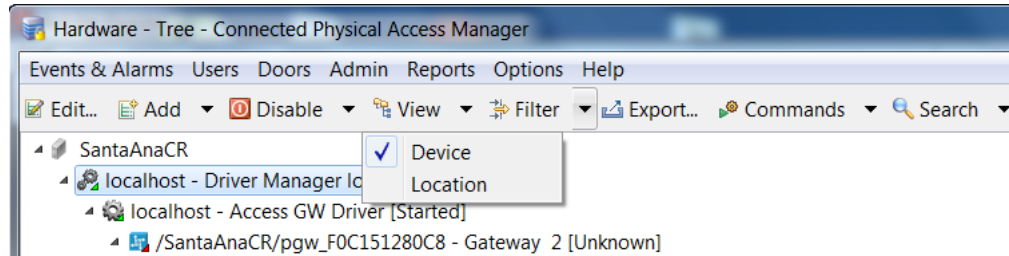

**Step 3** Add a Gateway to ICPAM.

- a. Right-click on the **Access GW Driver**, and choose the **New Gateway Controller** command from the pop-up menu.

**Note** Gateways can also be automatically added to the configuration. See [Provisioned \(Pre-Populated\) vs. Discovered Controller Configurations, page 5-2](#).

The **Choose Template** page of the New Gateway Controller wizard appears.

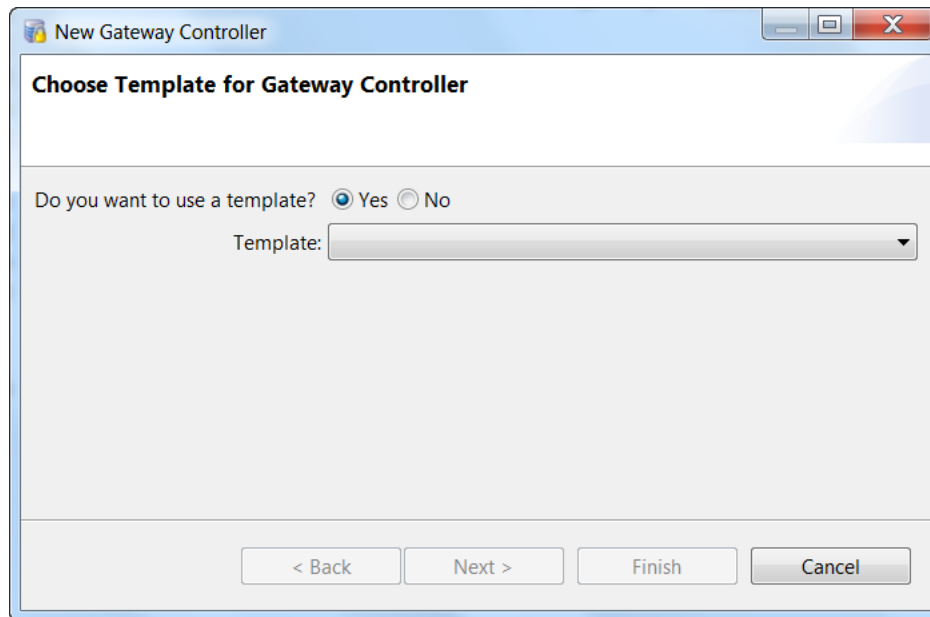

**Step 4** Select a Gateway controller template.

- a. Select **Yes**.
- b. Select an existing template from the **Template** drop-down list.
- c. Click **Next**.

**Note** ICPAM includes sample templates. To create or modify templates, see the [“Understanding Door Configurations and Templates”](#) section on page 5-23 and Chapter 8, [“Configuring Door and Device Templates”](#).

**Step 5** On the resulting page, enter the name, serial number, and location of the controller.

- a. **Name:** enter a descriptive name to identify the controller.
- b. **Serial Number:** the serial number is unique and cannot be changed. See the [“Locating Serial Numbers”](#) section on page 5-40.
- c. **Location:** the assigned location of the module. See the [“Viewing Doors and Devices by Location”](#) section on page 5-7.

**Note** The Time Zone and Daylight Savings setting are not configurable if defined by the template.

- d. Click **Next**.



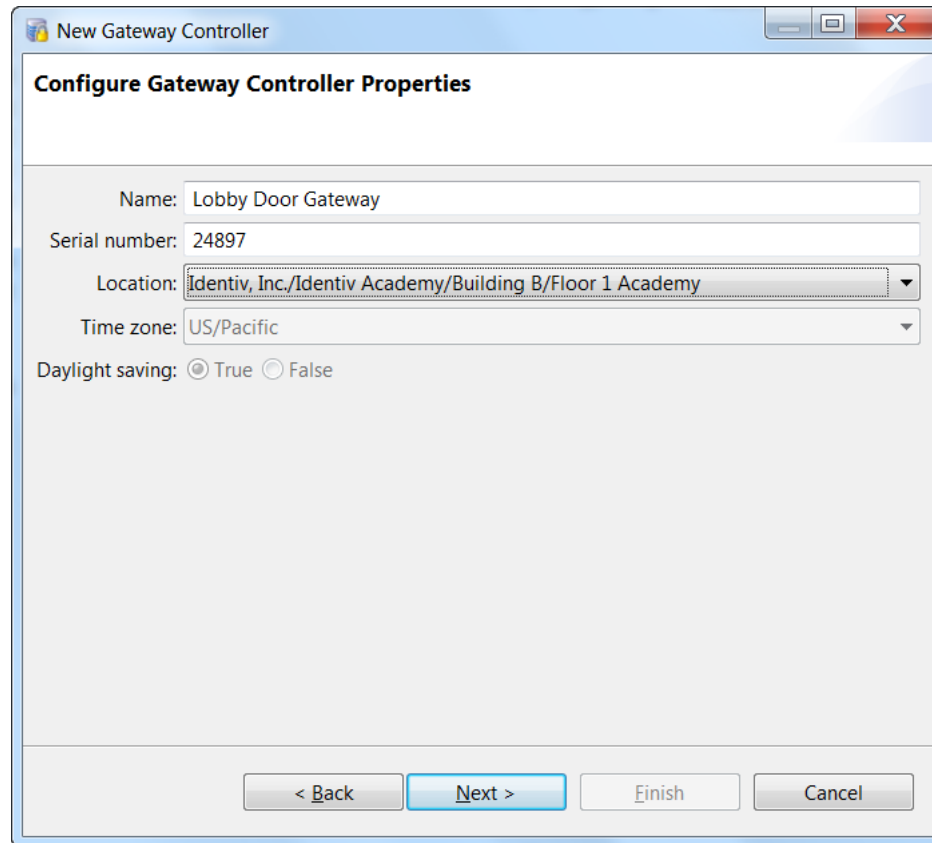

The screenshot shows a window titled "New Gateway Controller" with the subtitle "Configure Gateway Controller Properties". The window contains the following fields and controls:

- Name: Lobby Door Gateway
- Serial number: 24897
- Location: Identiv, Inc./Identiv Academy/Building B/Floor 1 Academy (dropdown menu)
- Time zone: US/Pacific (dropdown menu)
- Daylight saving:  True  False

At the bottom of the window, there are four buttons: "< Back", "Next >" (highlighted in blue), "Finish", and "Cancel".

- Step 6** Edit or enter the properties for each module in the Gateway template.
- Select a module from the list (gateway, reader, input, or output).
  - Click **Edit**.
  - Enter a descriptive name for the device.
  - (Expansion modules only) Enter the serial number for the module. (The gateway serial number was entered on the previous page of the wizard).
  - (Reader module only) Select the Reader connection mode: one door or two door configuration.
  - Click **Update**.
  - Repeat these steps for each module in the list.
  - Click **Next**

**Add Additional Modules**

Name:

Serial number:

Module type:

Reader connection mode:

Name	Serial Num...	Module Type	Reader Con...	Module Nu...
m00	24897	Default Mo...	One Reader	m00

**Step 7** (Optional) If door configurations are included in the gateway template, assign each door to a location.

**Note** If door configurations are not included in the gateway template, complete these instructions, and then continue on to [Adding Doors Using Door Templates, page 7-3](#).

- a. Select a **Door template** from the drop-down list.
- b. Click **Edit**.
- c. Enter the following information:
  - **Door Name**: enter a descriptive name for the door.
  - **Door Location**: select a location for the door (see [Viewing Doors and Devices by Location, page 5-7](#)).
- d. Click **Update**.
- e. Repeat these steps for each available door.

- f. Click **Finish** to create the door configuration(s).

Door Name	Door Template	Door Location
	Training Door ...	

**Step 8** (Optional). Modify the door and device properties, if necessary.

- a. Select **Location & Doors** from the **Doors** menu.
- b. Navigate to the door by expanding the locations as necessary (click on the box next to an icon to expand or collapse the locations). The door is located under the location selected when adding the door.
- c. Double click the door or device to open its properties window (or right-click the door and select **Edit**).

To override any template setting, uncheck the Default box to activate the field.

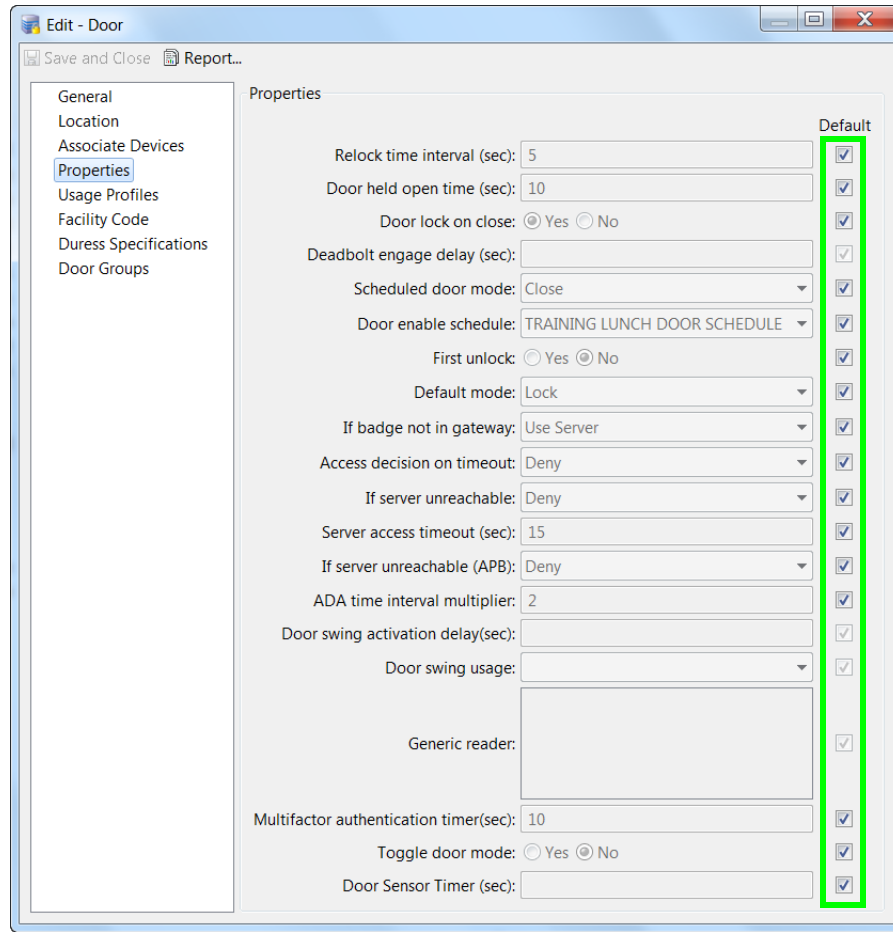

For more information, see the following:

- [Chapter 5, “Understanding Controller and Door Configurations”](#)
- [Door Configuration Properties, page 8-28](#)
- [Device Configuration Properties, page 8-30](#)

**Tip** You can also modify doors using the Hardware Tree module. Doors are listed under the logical device driver, or in the Hierarchical Locations view.

**Step 9** Select **Apply Configuration Changes** on the Access GW Driver or on a specific controller.

- To download the configuration changes to all gateways in the Up state, right-click on the **Access GW Driver** and select **Apply Configuration Changes**.

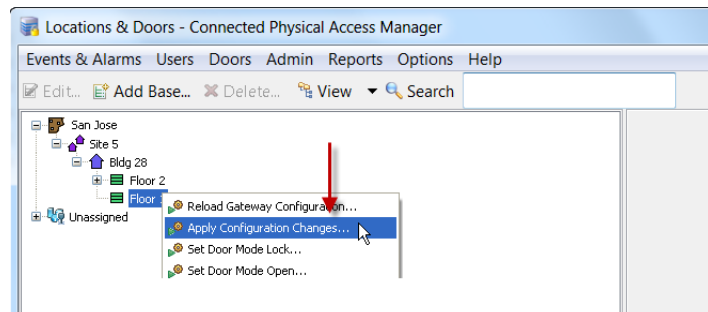

or

- To download configuration changes for a single gateway controller, right-click on that controller and select **Apply Configuration Changes**.

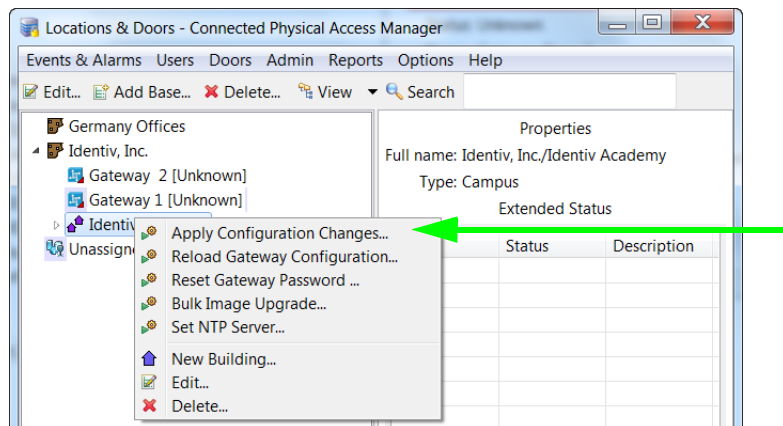

**Note** Controllers must be in the Up state, signified by a green triangle in the icon. A dark green triangle means there are configuration changes that have not been applied.

**Step 10** (Optional) Continue on to [Adding New Doors, page 7-2](#).



**Note**

Starting with ICPAM 2.1, if the profile enhancement feature is set in the system configuration settings (see [Logins page of the System Configuration window, page 17-11](#)), you can view only the gateways, modules, devices, and doors assigned to your location. For more information, see [Location-Restricted User Permissions, page 5-10](#).

## Creating Custom EM-100 Controller Configurations without Templates

To create a door and its attached devices, an Identiv EM-100 controller configuration must first be created that defines the modules and devices attached to the controller.

While ICPAM comes with a couple of default EM-100 controller templates, you can create your own controller templates by first creating custom controller configurations, then saving them as controller templates for use with the controller wizard (see [Configuring EM-100 Controllers Using Existing Templates, page 6-18](#)).

### Procedure:

Complete the following instructions to create a custom controller configuration without using an existing controller template, then save it as a template.

- Step 1** If required, create the locations for door and devices. (If this has already been done, proceed to **Step 2**.)
- Select **Door/Location-based Hardware** from the **Doors** menu.
  - To create a new site, click **Add Base**.
  - To create a sub-location, right-click a location and select **New [Element]**.
  - To change the properties for an element, right-click a location and select **Edit**.

**Tip**

You can create any combination of location elements. Door configurations can be assigned to any level of the hierarchical tree.

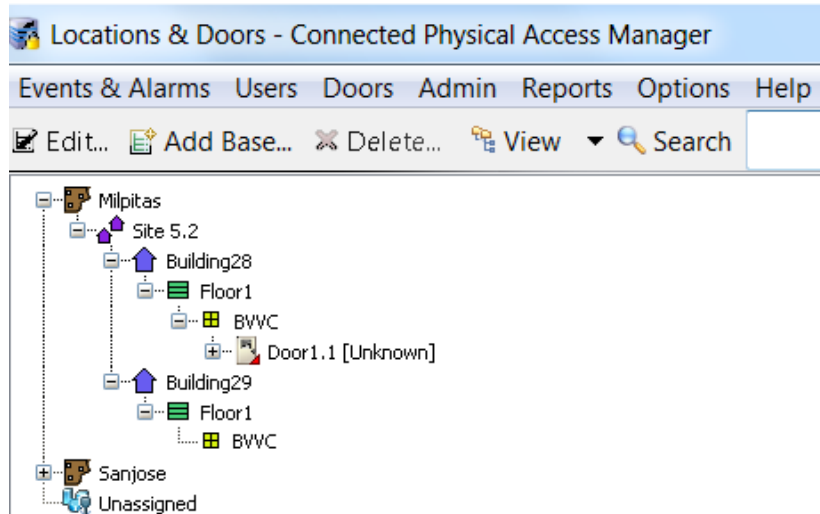

- Step 2** Open the Hardware Tree module in the Device view.
- Select **Hardware Tree** from the **Doors** menu.
  - Select **Device** from the **View** menu.

**Tip**

See also [Viewing Doors and Devices in the Hardware Tree View, page 5-4](#).

- Step 3** Add a controller.
- From the hardware tree, right-click the Identiv EM-100 Driver.
  - From the drop-down list, select **New Identiv EM-100 Controller...**
- The Identiv EM-100 property sheets appear with the General page displayed.
- Step 4** Enter the general controller properties.
- For details on the fields, refer to [Controller General Property Page, page 6-46](#).
- Step 5** Click the **Location** tab and the Location page appears.
- Step 6** Specify the location of this controller.
- For details on the fields, refer to [Controller Location Property Page, page 6-47](#).
- Step 7** Click the **Configuration** tab and the Configuration page appears.
- Step 8** Supply fields for this page as required.
- For details on this page, refer to [Controller Configuration Page, page 6-47](#).
- Step 9** Click the **Calendar and Time Zone** tab. The Calendar and Time Zone page appears.
- For details on this page, refer to [Controller Calendar and Time Zone Page, page 6-48](#).
- Step 10** Fill out other pages of the property sheet as needed.
- Step 11** When you are finished, click the **Save and Close** button.
- The new controller appears in the Hardware Tree.

**Step 12** Apply the configuration changes to download the new settings to the devices.

- To update all controllers: right-click the parent Identiv EM-100 Driver and select **Apply Configuration Changes...**
- To update a single gateway: right-click the newly-created controller and select **Apply Configuration Changes...**



**Note** Controllers must be in the Up state, signified by a green triangle in the icon. A dark green triangle means there are configuration changes that have not been applied. For more information, see [Applying Configuration Changes, page 7-14](#).

**Step 13** (Optional) Create a controller template from the new configuration.

- Right-click on the required controller and select **Save As Wizard Template**. The Save As Wizard Template window appears:

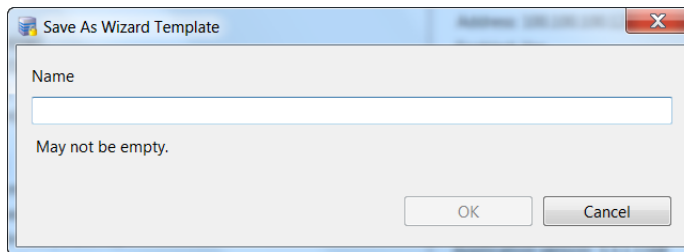

- Enter a name for the template and click **OK**.

The new controller template is available in the main gateway templates window (see [Figure 6-2](#)) and can be used in the EM-100 Controller Wizard. For more on using created controller templates to define still more controllers, refer to [Configuring EM-100 Controllers Using Existing Templates, page 6-18](#).

**Step 14** (Optional) Add the door configuration that use the ports on the gateway. See [Adding New Doors, page 7-2](#).

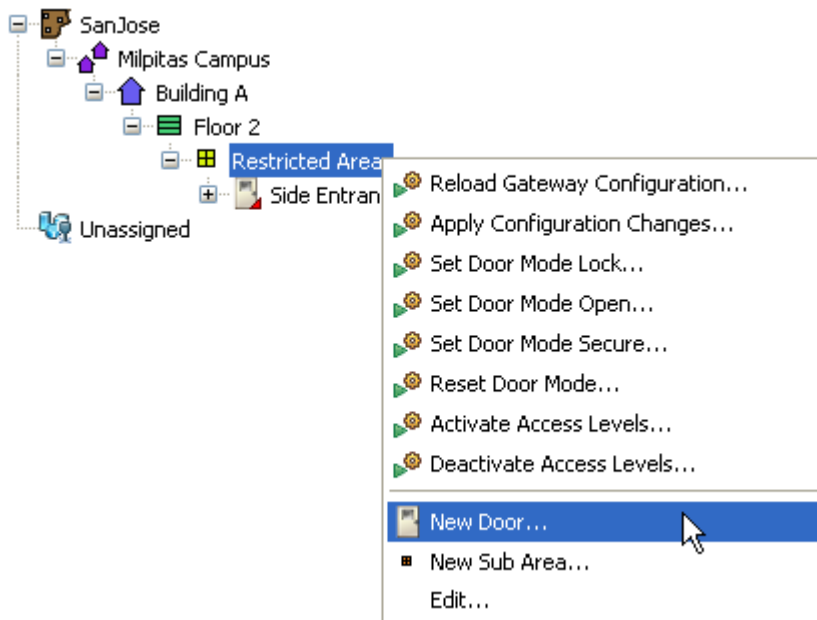

## Configuring EM-100 Controllers Using Existing Templates

Pre-defined EM-100 controller templates enable you to quickly add a new Identiv EM-100 single-door controller to your ICPAM system. Templates are provided for adding a new:

- standard EM-100 controller which supports only an entry reader
- EM-100 controller with a connected Exit Reader Expansion Module, which supports both the standard entry reader and an exit reader

For information about creating or modifying templates, see the “[Understanding Door Configurations and Templates](#)” section on page 5-23 and [Chapter 8, “Configuring Door and Device Templates”](#).



**Note**

If you are adding an optional Exit Reader Expansion Module to an EM-100 controller which is already part of your ICPAM system, see [Adding an Exit Reader to the Door of an EM-100 Controller, page 7-29](#).

### Adding a Standard EM-100 Controller (with Only an Entry Reader)

To add a new standard Identiv EM-100 controller (which supports only an entry reader) to your ICPAM system using a controller template, perform the steps in the following procedure.



**Note**

Controllers can also be automatically added to the configuration. See [Provisioned \(Pre-Populated\) vs. Discovered Controller Configurations, page 5-2](#).

- Step 1** If necessary, create the locations for the new controller’s door and its devices. (If the locations have already been created, skip to **Step 2**.)
- a. Select the **Doors > Door/Location-based Hardware** command.
  - b. To create a new site, click the **Add Base...** button in the toolbar.
  - c. To create a sub-location, right-click on a location and choose **New [Element]** from the pop-up menu.
  - d. To change the properties of an element, right-click on a location and choose **Edit** from the pop-up menu.
- Tip** You can create any combination of location elements, and door configurations can be assigned to any level of the hierarchical tree. For more information, see [Creating the Location Map, page 5-8](#).
- Step 2** Open the Hardware Tree module by selecting **Doors > Hardware - Tree**, and if necessary select **View > Device**.
- Step 3** Expand the Driver Manager portion of the tree so the appropriate Identiv EM-100 Driver is visible, then right-click on it and choose the **New Identiv EM-100 Controller Wizard...** command from the pop-up menu.



**Step 4** On the resulting **Choose Template** page of the wizard:

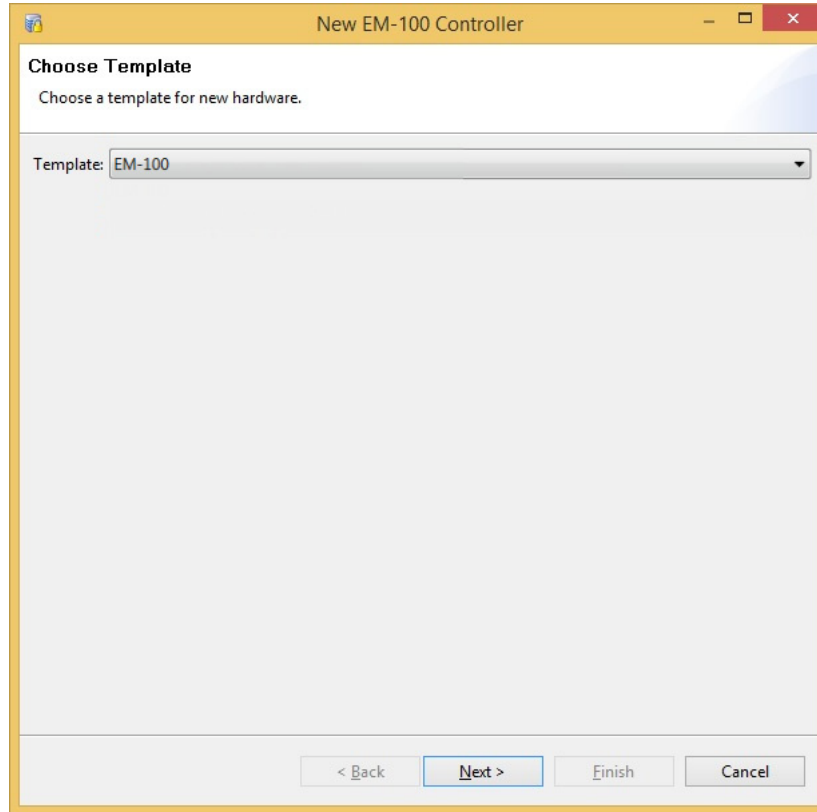

- a. In the **Template** drop-down list, accept the default selection of the **EM-100** template. This template is used for a standard Identiv EM-100 controller (which supports only an entry reader).
- b. Click **Next**.

**Step 5** On the resulting **Device Name** page of the wizard, specify the new controller's name:

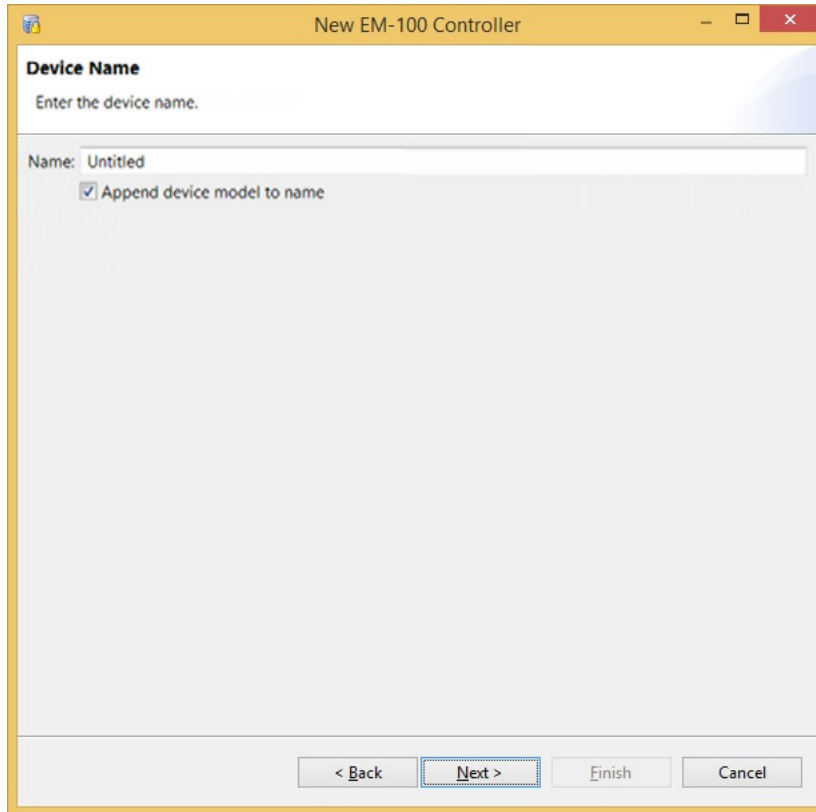
The image shows a screenshot of a Windows-style dialog box titled "New EM-100 Controller". The dialog has a yellow title bar with standard minimize, maximize, and close buttons. The main content area is titled "Device Name" and contains the instruction "Enter the device name." Below this is a text input field labeled "Name:" containing the text "Untitled". Underneath the input field is a checked checkbox labeled "Append device model to name". At the bottom of the dialog, there are four buttons: "< Back", "Next >" (which is highlighted with a blue border), "Finish", and "Cancel".

- a. In the **Name** field, type a descriptive name for this controller, which must be unique within the Identiv EM-100 Driver portion of the Hardware Tree.
- b. Leave the **Append device model to name** option checked if you want to have the text “EM-100” added to the end of the controller’s name, or clear the check box if you do not want that text added to the controller’s name.
- c. Click **Next**.

**Step 6** On the resulting **Location** page of the wizard, specify the new controller's location:

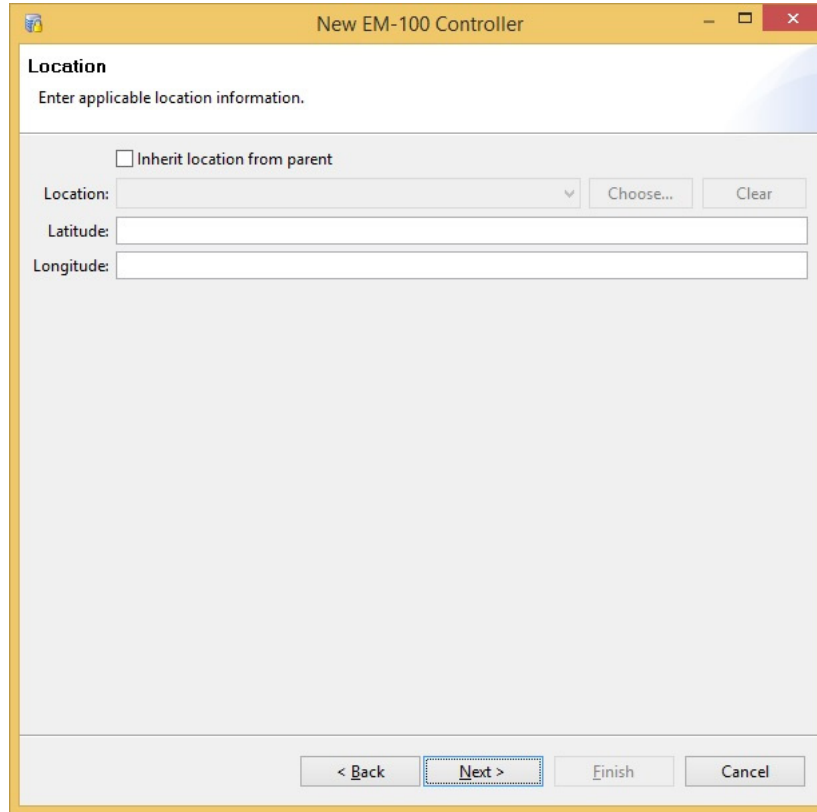

The screenshot shows a window titled "New EM-100 Controller" with a "Location" section. The section contains the instruction "Enter applicable location information." and a checkbox labeled "Inherit location from parent". Below this is a "Location:" dropdown menu with "Choose..." and "Clear" buttons. There are also text input fields for "Latitude:" and "Longitude:". At the bottom of the window are navigation buttons: "< Back", "Next >" (highlighted with a blue border), "Finish", and "Cancel".

- a. Check the box for the **Inherit location from parent** option if you want this controller to inherit its location from the location specified for the Identiv EM-100 device driver.
- b. If the hierarchical location map has been defined for your ICPAM system, then you can select this controller's location from the **Location** drop-down list.
  - To view the available locations as the hierarchical location map (instead of a flat drop-down list), click the **Choose...** button.
  - To clear the current value displayed in the **Location** drop-down list, click the **Clear** button.

For more information about locations, see [Viewing Doors and Devices by Location, page 5-7](#) and [Creating the Location Map, page 5-8](#).

- c. (Optional) Type the **Latitude** and **Longitude** coordinates for this controller's location. If this controller is attached to a Network Time Protocol server, the Latitude and Longitude fields are automatically populated.
- d. Click **Next**.

**Step 7** On the resulting **Controller** page of the wizard, specify the address and time zone for this new controller:

- a. In the **Host / IP address** field, type the designated IP v4 address for this controller. (Hostname is not supported for an EM-100 controller.)

This value must match the value specified using the EM-100 controller's built-in configuration utility. For details, see "Configuring an EM-100 Controller" in the *ICPAM Installation Guide*.

- b. (Optional) In the **MAC address** field, type the Media Access Control address of this controller, which is a unique 12-digit hexadecimal number (such as 00:06:8E:40:XX:XX) plus 5 colons separating the 6 pairs of hex digits.

The MAC address is printed on a label located on the bottom edge of the EM-100 controller.

- c. From the **Time Zone** drop-down list, select the time zone where this controller is currently located.
- d. Click **Next**.

**Step 8** On the resulting **Door 1** page of the wizard, configure the door and its entry reader:

- a. In the **Name** field, type a name for this door, which must be unique within the Identiv EM-100 Driver portion of the Hardware Tree. (If your site does not follow a specific naming convention, you might want to use a descriptive name such as “Enter QA Lab”.)
- b. From the **Access mode** drop-down list, select the access mode for this door’s entry reader. Depending on your System Configuration settings, the choices might include **Card only**, **PIN only**, **Card and PIN**, and **Card or PIN**.  
Note that to use one of the PIN access modes, the card reader must be equipped with a numeric keypad, and user credentials must include a PIN code. For more information, refer to [Configuring an EM-100 Controller with the Desired Access Mode](#), page 6-33.
- c. If this door is equipped with a contact switch, select the type of supervision to be applied for that switch, from the **Door contact supervision** drop-down list.
- d. If this door has an associated “Request to Exit” (a.k.a. REX) button, select the type of supervision to be applied for that button, from the **REX supervision** drop-down list.
- e. From the **Keypad type** drop-down list, select the appropriate value for this exit reader. The choices are **[no keypad]**, **4-bit burst mode**, **8-bit burst mode**, or **Mercury**.
- f. Click **Finish** to close this wizard.

This new controller and its door are added to the hardware tree.

**Step 9** (Optional) If necessary, modify the door and device properties.

- a. Open the Locations hierarchical map by selecting the **Doors > Location & Doors** command.

- b. Expand the hierarchy as needed and navigate to the new door. (The door appears where you specified on the **Location** page of the wizard for adding a new EM-100 controller, in **Step 6** of this procedure.)
- c. Open the door's properties window, either by double-clicking on it, or by right-clicking on it and choosing **Edit** from the pop-up menu.

For example:

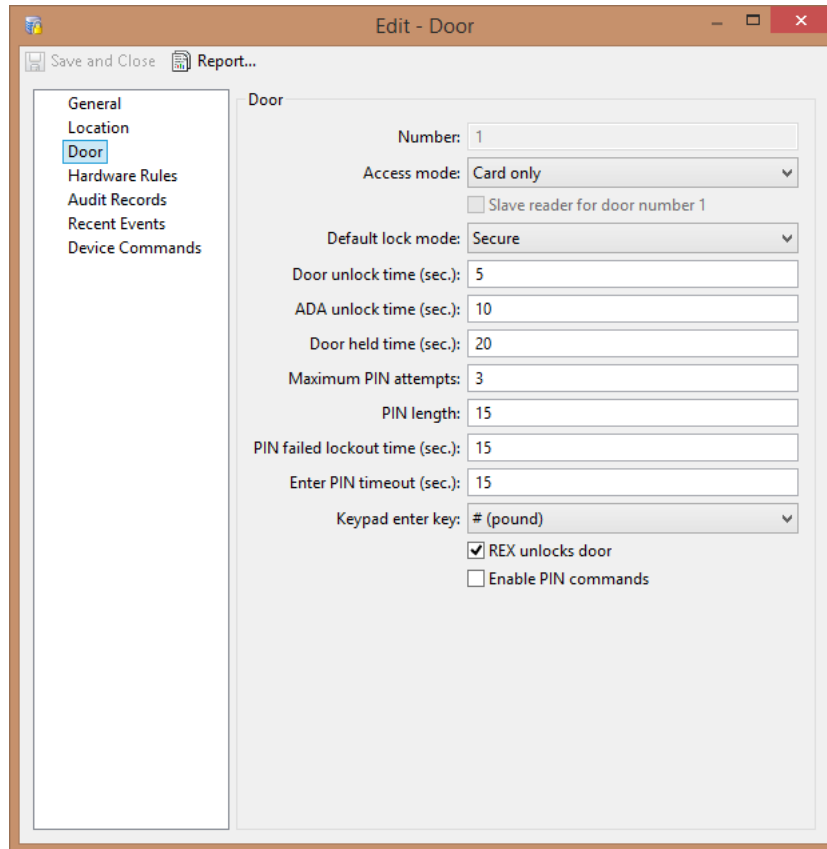

For more information, see [Door Configuration Properties](#), page 8-28 and [Device Configuration Properties](#), page 8-30.

- Step 10** Download the configuration to this new EM-100 controller, by right-clicking on that controller (in either the Hardware Tree or the Locations hierarchy) and choosing the **Apply Configuration Changes** command from the pop-up menu.

For more information, see [Applying Configuration Changes to Controllers](#), page 6-50.

- Step 11** Restart the Identiv EM-100 Driver, to activate the new controller.

### Related Documentation

For more information, see the following:

- [Chapter 5, “Understanding Controller and Door Configurations”](#)
- [Chapter 8, “Configuring Door and Device Templates”](#)

## Adding an EM-100 Controller with an Exit Reader Expansion Module

To add a new Identiv EM-100 controller with an optional Exit Reader Expansion Module (which supports both the standard entry reader and an exit reader) to your ICPAM system using a controller template, perform the steps in the following procedure.

**Note**

Controllers can also be automatically added to the configuration. See [Provisioned \(Pre-Populated\) vs. Discovered Controller Configurations, page 5-2](#).

- Step 1** If necessary, create the locations for the new controller's door and its devices. (If the locations have already been created, skip to **Step 2**.)
- Select the **Doors > Door/Location-based Hardware** command.
  - To create a new site, click the **Add Base...** button in the toolbar.
  - To create a sub-location, right-click on a location and choose **New [Element]** from the pop-up menu.
  - To change the properties of an element, right-click on a location and choose **Edit** from the pop-up menu.

If this has already been done, proceed to Step 2.

**Tip** You can create any combination of location elements, and door configurations can be assigned to any level of the hierarchical tree. For more information, see [Creating the Location Map, page 5-8](#).

- Step 2** Open the Hardware Tree module by selecting **Doors > Hardware - Tree**, and if necessary select **View > Device**.
- Step 3** Expand the Driver Manager portion of the tree so the appropriate Identiv EM-100 Driver is visible, then right-click on it and choose the **New Identiv EM-100 Controller Wizard...** command from the pop-up menu.

**Step 4** On the resulting **Choose Template** page of the wizard:

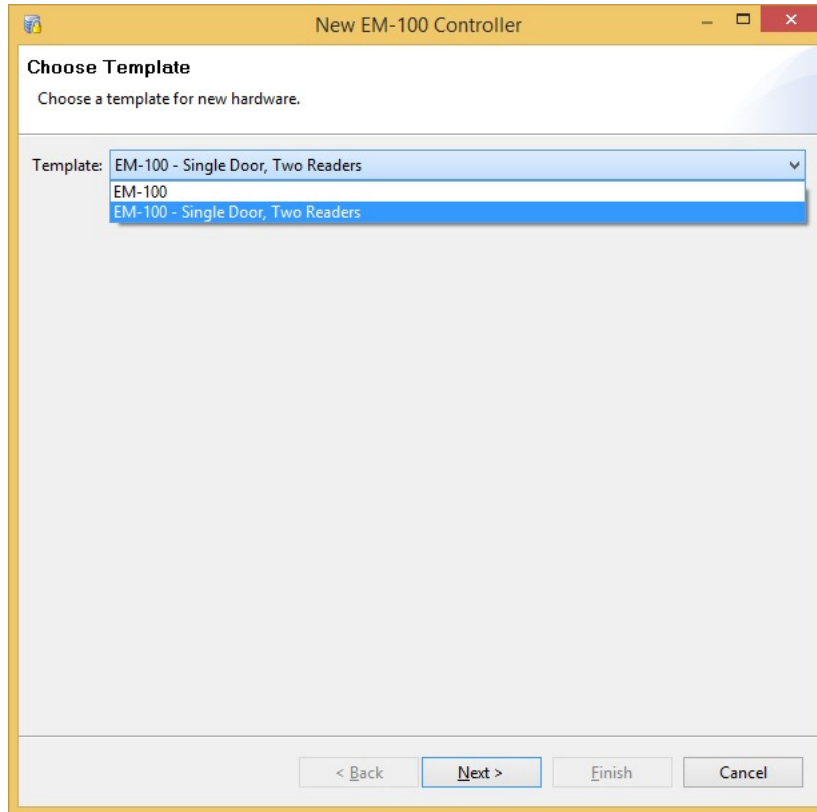

- a. In the **Template** drop-down list, select the **EM-100 - Single Door, Two Readers** template.
- b. Click **Next**.



**Step 5** On the resulting **Device Name** page of the wizard, specify the new controller's name:

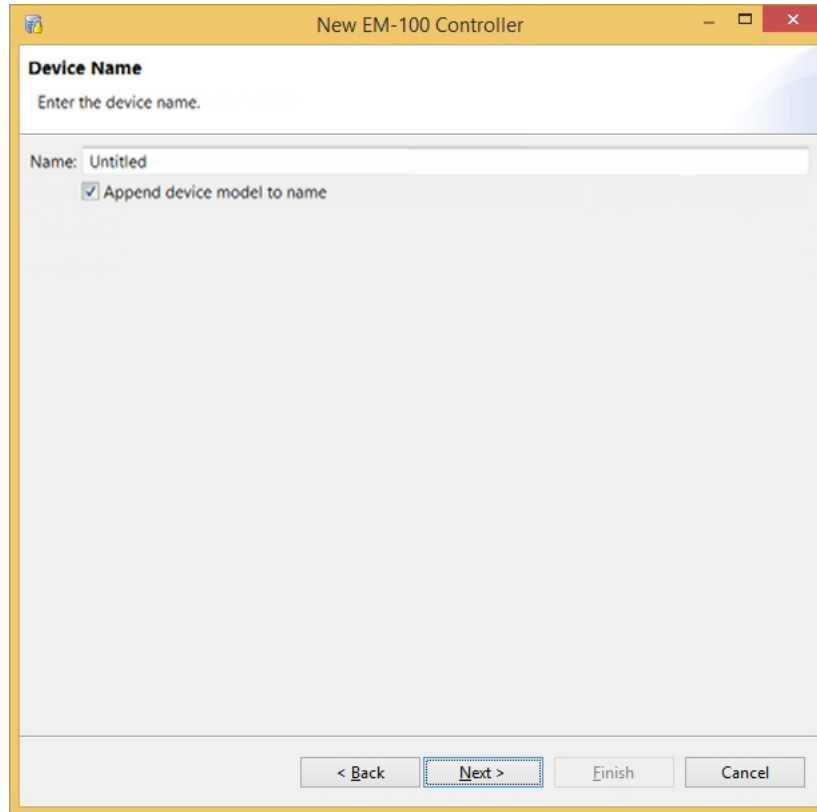

The screenshot shows a window titled "New EM-100 Controller" with a "Device Name" section. The instruction "Enter the device name." is displayed. Below it, a text field labeled "Name:" contains the text "Untitled". A checkbox labeled "Append device model to name" is checked. At the bottom of the window, there are four buttons: "< Back", "Next >" (which is highlighted with a blue border), "Finish", and "Cancel".

- a. In the **Name** field, type a descriptive name for this controller, which must be unique within the Identiv EM-100 Driver portion of the Hardware Tree.
- b. Leave the **Append device model to name** option checked if you want to have the text “EM-100R2” added to the end of the controller’s name, or clear the check box if you do not want that text added to the controller’s name.
- c. Click **Next**.

**Step 6** On the resulting **Location** page of the wizard, specify the new controller's location:

- a. Check the box for the **Inherit location from parent** option if you want this controller to inherit its location from the location specified for the Identiv EM-100 device driver.
- b. If the hierarchical location map has been defined for your ICPAM system, then you can select this controller's location from the **Location** drop-down list.
  - To view the available locations as the hierarchical location map (instead of a flat drop-down list), click the **Choose...** button.
  - To clear the current value displayed in the **Location** drop-down list, click the **Clear** button.

For more information about locations, see [Viewing Doors and Devices by Location, page 5-7](#) and [Creating the Location Map, page 5-8](#).

- c. (Optional) Type the **Latitude** and **Longitude** coordinates for this controller's location. If this controller is attached to a Network Time Protocol server, the Latitude and Longitude fields are automatically populated.
- d. Click **Next**.

**Step 7** On the resulting **Controller** page of the wizard, specify the address and time zone for this new controller:

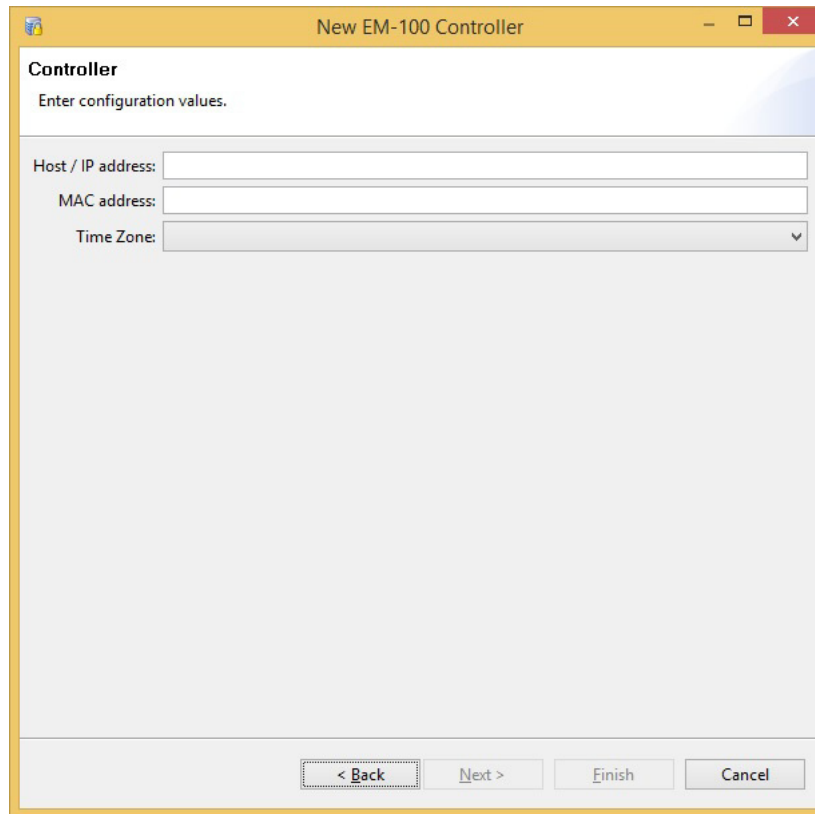

- a. In the **Host / IP address** field, type the designated IP v4 address for this controller. (Hostname is not supported for an EM-100 controller.)

This value must match the value specified using the EM-100 controller's built-in configuration utility. For details, see "Configuring an EM-100 Controller" in the *ICPAM Installation Guide*.

- b. (Optional) In the **MAC address** field, type the Media Access Control address of this controller, which is a unique 12-digit hexadecimal number (such as 00:06:8E:40:XX:XX) plus 5 colons separating the 6 pairs of hex digits.

The MAC address is printed on a label located on the bottom edge of the EM-100 controller.

- c. From the **Time Zone** drop-down list, select the time zone where this controller is currently located.
- d. Click **Next**.

**Step 8** On the resulting **Door 1** page of the wizard, configure the door and its entry reader:

- a. In the **Name** field, type a name for this door, which must be unique within the Identiv EM-100 Driver portion of the Hardware Tree. (If your site does not follow a specific naming convention, you might want to use a descriptive name such as “Enter QA Lab”.)
- b. From the **Access mode** drop-down list, select the access mode for this door’s entry reader. Depending on your System Configuration settings, the choices might include **Card only**, **PIN only**, **Card and PIN**, and **Card or PIN**.  
Note that to use one of the PIN access modes, the card reader must be equipped with a numeric keypad, and user credentials must include a PIN code. For more information, refer to [Configuring an EM-100 Controller with the Desired Access Mode](#), page 6-33.
- c. If this door is equipped with a contact switch, select the type of supervision to be applied for that switch, from the **Door contact supervision** drop-down list.
- d. If this door has an associated “Request to Exit” (a.k.a. REX) button, select the type of supervision to be applied for that button, from the **REX supervision** drop-down list.
- e. From the **Keypad type** drop-down list, select the appropriate value for this exit reader. The choices are **[no keypad]**, **4-bit burst mode**, **8-bit burst mode**, or **Mercury**.
- f. Click **Next**.

- Step 9** On the resulting **Door 2** page of the wizard, configure the exit reader (for this EM-100 single-door controller):

- a. In the **Name** field, type a name for this exit reader, which must be unique within the Identiv EM-100 Driver portion of the Hardware Tree. (If your site does not follow a specific naming convention, you might want to use a descriptive name such as “Exit QA Lab”.)
- b. From the **Access mode** drop-down list, select the access mode for this door’s exit reader. Depending on your System Configuration settings, the choices might include **Card only**, **PIN only**, **Card and PIN**, and **Card or PIN**.

Note that to use one of the PIN access modes, the card reader must be equipped with a numeric keypad, and user credentials must include a PIN code. For more information, refer to [Configuring an EM-100 Controller with the Desired Access Mode](#), page 6-33.

The **Door contact supervision** drop-down list is disabled on this page about the exit reader; its value is specified on the previous **Door 1** page about the entry reader.

The **REX supervision** drop-down list is disabled on this page about the exit reader; its value is specified on the previous **Door 1** page about the entry reader.

- c. From the **Keypad type** drop-down list, select the appropriate value for this exit reader. The choices are **[no keypad]**, **4-bit burst mode**, **8-bit burst mode**, or **Mercury**.
- d. Click **Finish** to close this wizard.

This new controller and its door (with both an entry reader and an exit reader) are added to the hardware tree.

- Step 10** (Optional) If necessary, modify the door and device properties.
- Open the Locations hierarchical map by selecting the **Doors > Location & Doors** command.
  - Expand the hierarchy as needed and navigate to the new door. (The door appears where you specified on the **Location** page of the wizard for adding a new EM-100 controller, in **Step 6** of this procedure.)
  - Open the door's properties window, either by double-clicking on it, or by right-clicking on it and choosing **Edit** from the pop-up menu.

For example:

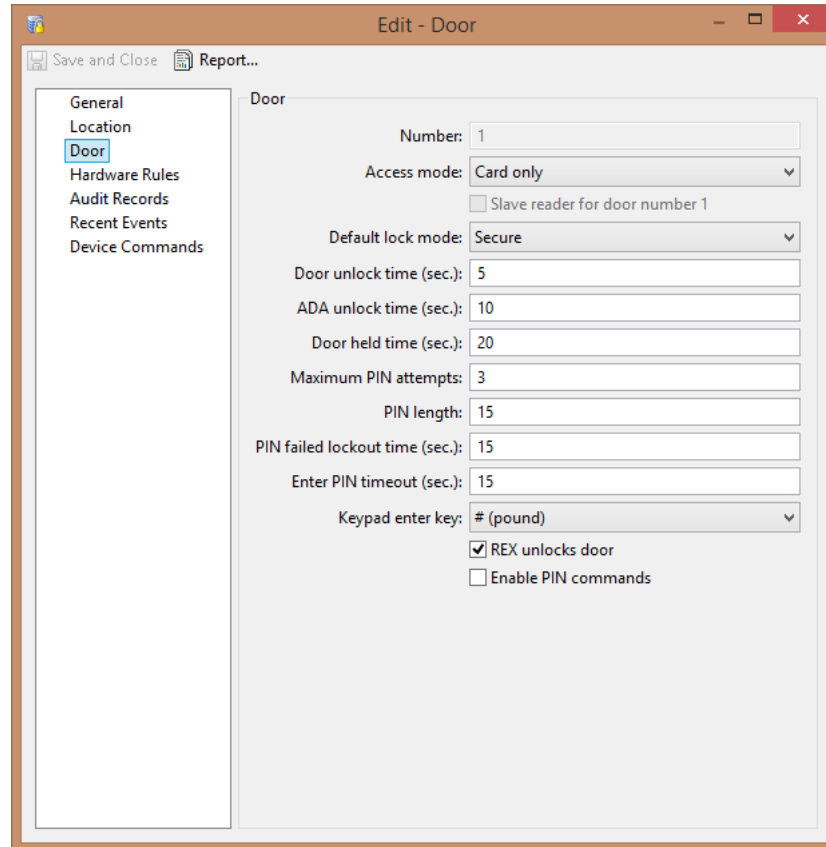

For more information, see [Door Configuration Properties, page 8-28](#) and [Device Configuration Properties, page 8-30](#).

- Step 11** Download the configuration to this new EM-100 controller, by right-clicking on that controller (in either the Hardware Tree or the Locations hierarchy) and choosing the **Apply Configuration Changes** command from the pop-up menu.

For more information, see [Applying Configuration Changes to Controllers, page 6-50](#).

- Step 12** Restart the Identiv EM-100 Driver, to activate the new controller.

## Configuring an EM-100 Controller with the Desired Access Mode

Access to a secured area can be managed based on three different authentication factors:

- Something that you **have**, such as an ID badge or card.
- Something that you **know**, such as a PIN code.
- Something that you **are**, such as a fingerprint or a retinal scan.

Security increases as you require more of these factors to gain access. However, each factor increases the time to enter and the cost of controlling access. Biometric readers are typically expensive and thus are used primarily in certain portions of high-security facilities. To balance security versus convenience and cost, most facilities are designed with multiple levels of security, with a different combination of factors required to gain access to each level.

In ICPAM, the combination of factors required to gain access to a particular secured area is specified by the **Access mode** property of a door's entry and exit readers. The possible values are:

- **Card only**
- **PIN only**
- **Card and PIN**
- **Card or PIN**

Note that to use one of the PIN access modes, the card reader must be equipped with a numeric keypad, and user credentials must include a PIN code. There are also certain System Configuration options which must be set correctly for the different access modes, as shown in the following topics.

### Configuring an EM-100 Controller for Access Using Only a PIN Code

If you want a user to be granted access when they enter only a PIN code at a card reader with a keypad (such as an IDENTIV 8235 TS Scramblepad Reader), then you must perform the following steps.

- 
- Step 1** Open the **System Configuration** window, by choosing the **Admin > System Configuration** command from the menu bar of the current module or window.
  - Step 2** Select the **Badges** item from the list on the left.

- Step 3** Make sure that the **Use PIN** option is checked, the **Require PIN to be unique** option is checked, and the **Allow null PIN** option is unchecked.

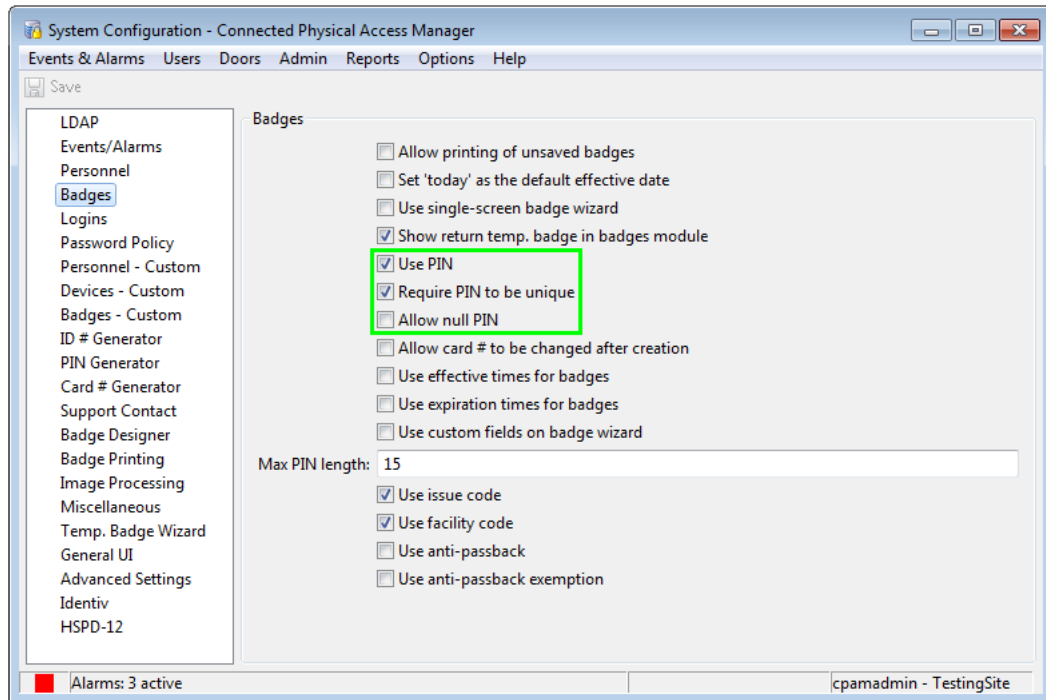

**Caution** If badges were previously created when the **Require PIN to be unique** option was not checked, it is possible that some of those badges might have the same PIN value. Review the existing badges in your system, and if necessary, reissue some badges to ensure that each one has a unique PIN value.

- Step 4** Select the **Identiv** item from the list on the left.



- Step 5** Make sure that the **Enable PIN-only access for badges by default** option is checked, and click the **Save** button.

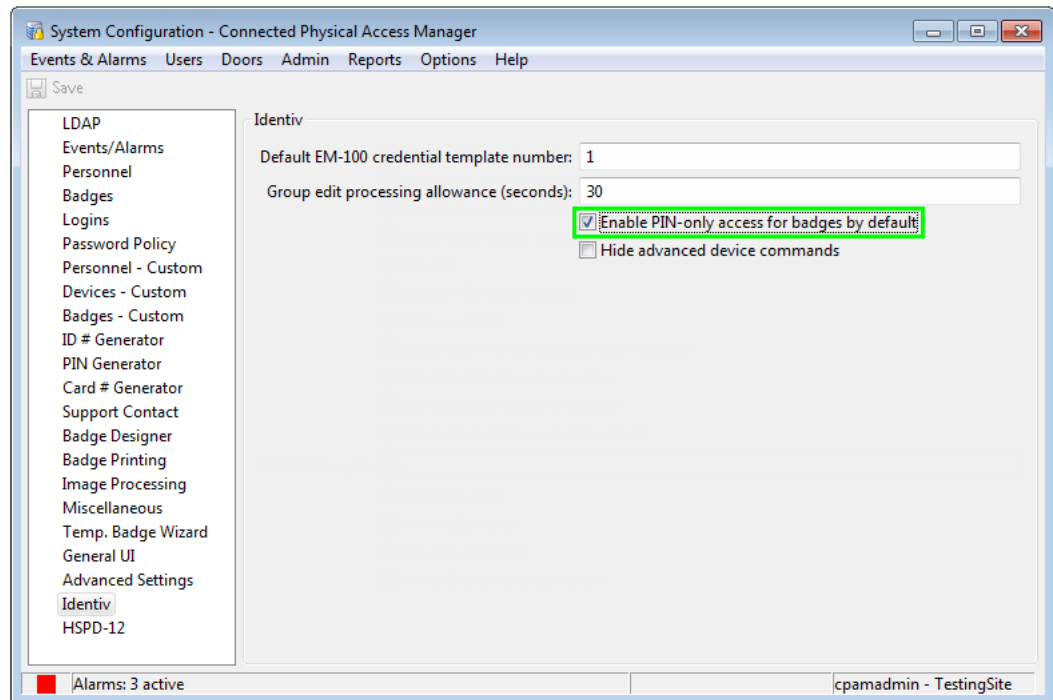

- Step 6** If you changed the setting of an option in **Step 3** or **Step 5**, to make the change in the system configuration take effect, you must log out of the ICPAM Client, and then log in to the ICPAM Client again.
- Step 7** Display the **Hardware Tree** window, by choosing the **Doors > Hardware Tree** command from the menu bar of the current module or window.
- Step 8** If necessary, choose the **View > Device** command from the menu bar.
- Step 9** Expand the tree beneath the **Identiv EM-100 Driver** to show the **Door** of the appropriate EM-100 Controller.
- Step 10** Right-click on that Door and choose the **Edit...** command from the pop-up menu.
- Step 11** On the resulting **Edit - Door** dialog, select the **Door** item from the list on the left.

**Step 12** From the **Access mode** drop-down list, select the **PIN only** option.

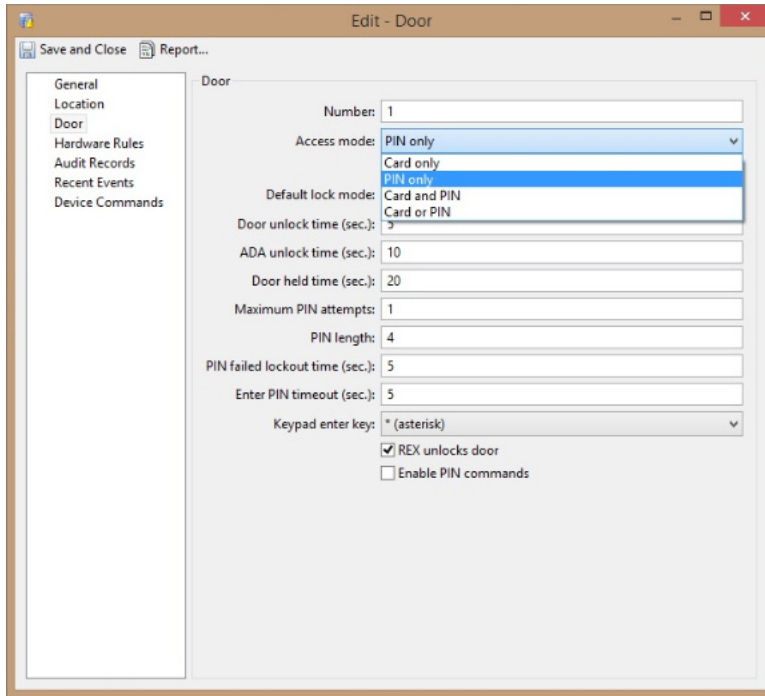

(For more information about access modes, refer to [Configuring an EM-100 Controller with the Desired Access Mode, page 6-33.](#))

**Step 13** Click the **Save and Close** button, to save this change and close the **Edit - Door** dialog.

**Step 14** In the **Hardware Tree** window, right-click on the Door’s EM-100 Controller (or the parent **Identiv EM-100 Driver**), and choose the **Apply Configuration / Credential Changes** command from the pop-up menu.

- Step 15** After the changes have been applied, select the Door's EM-100 Controller, and check the **Cards loaded** information (in the **Extended Status** area).

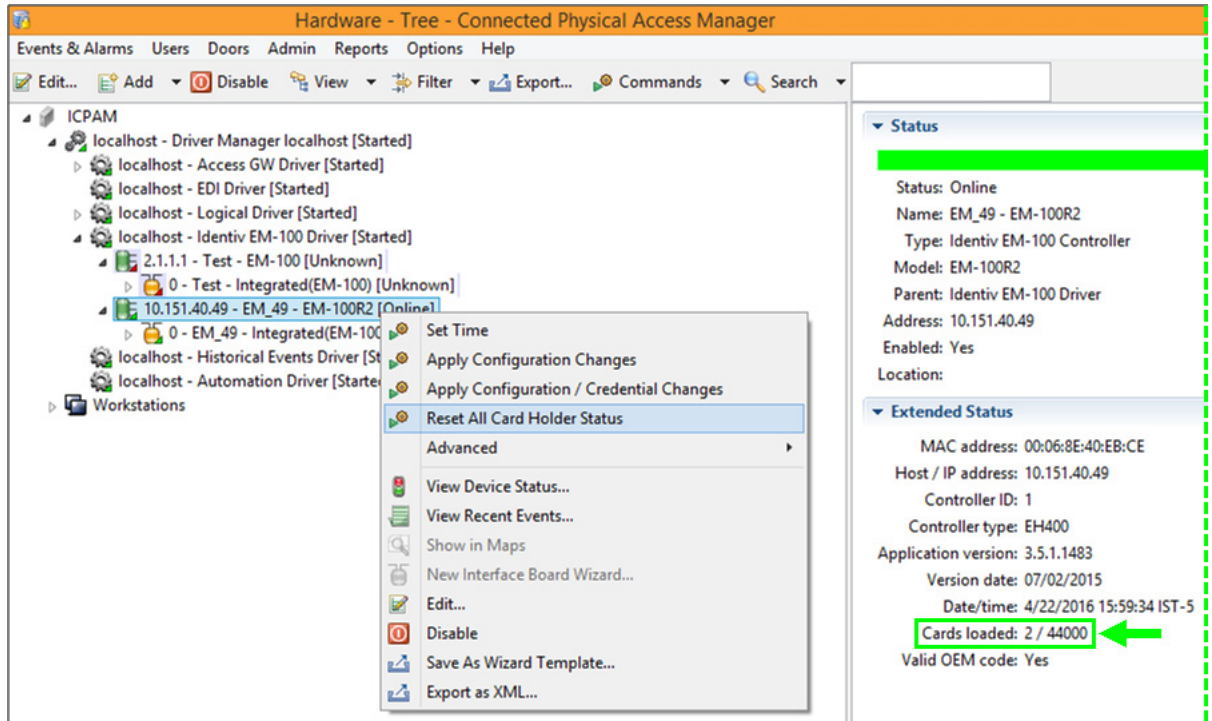

**Note** Because we are enabling **PIN only** access, the EM-100 controller treats the badge number and the PIN as two separate badges / credentials. For example, on a system with a single badge which is configured with a PIN and enabled with PIN only access, the Cards loaded information will show 2/44000.

- Step 16** Each of the doors managed by your set of EM-100 controllers can have a different **Access mode**. For every other Door that also must be configured to have PIN only access, repeat Steps 9 through 15.
- Step 17** To verify that the system is working properly:
- Open the **Events** window, by choosing the **Events & Alarms > Monitoring > Events** command from the menu bar of the current module or window.
  - Enter a valid PIN code at a keypad-equipped card reader which is configured for **PIN only** access.
  - Confirm that access is granted at the door, and that an **Access Granted** event is displayed in the **Events** window.

## Configuring an EM-100 Controller for Access Using a Card and a PIN Code

If you want a user to be granted access only when they both present a valid card and enter the associated PIN code (at a card reader with a keypad, such as an IDENTIV 8235 TS Scramblepad Reader), then you must configure your EM-100 controller and its card reader in ICPAM so that:

- “**Card and PIN**” is selected as the **Access mode** in the Door object of the hardware tree. For example:

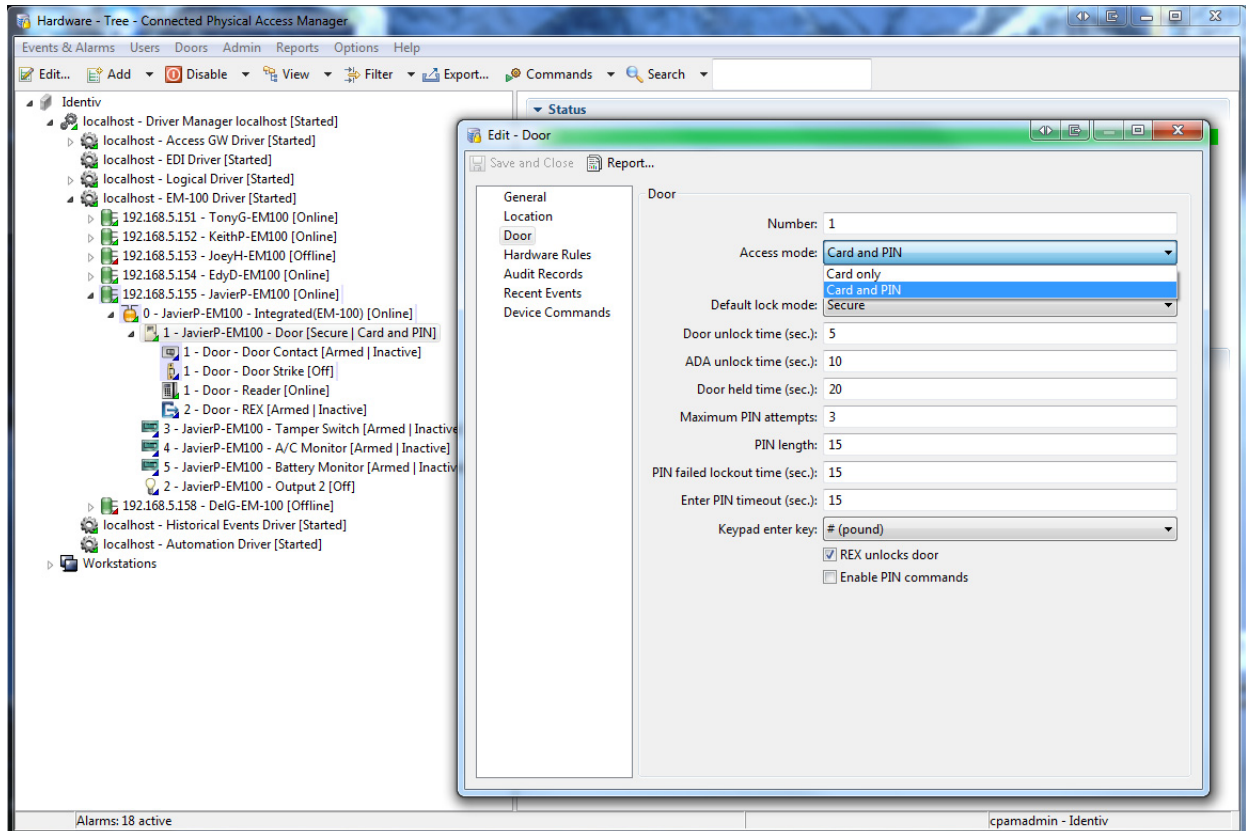

(For more information about access modes, refer to [Configuring an EM-100 Controller with the Desired Access Mode](#), page 6-33.)

- “4-bit burst mode” is selected as the **Keypad type** in the Reader object in the hardware tree. For example:

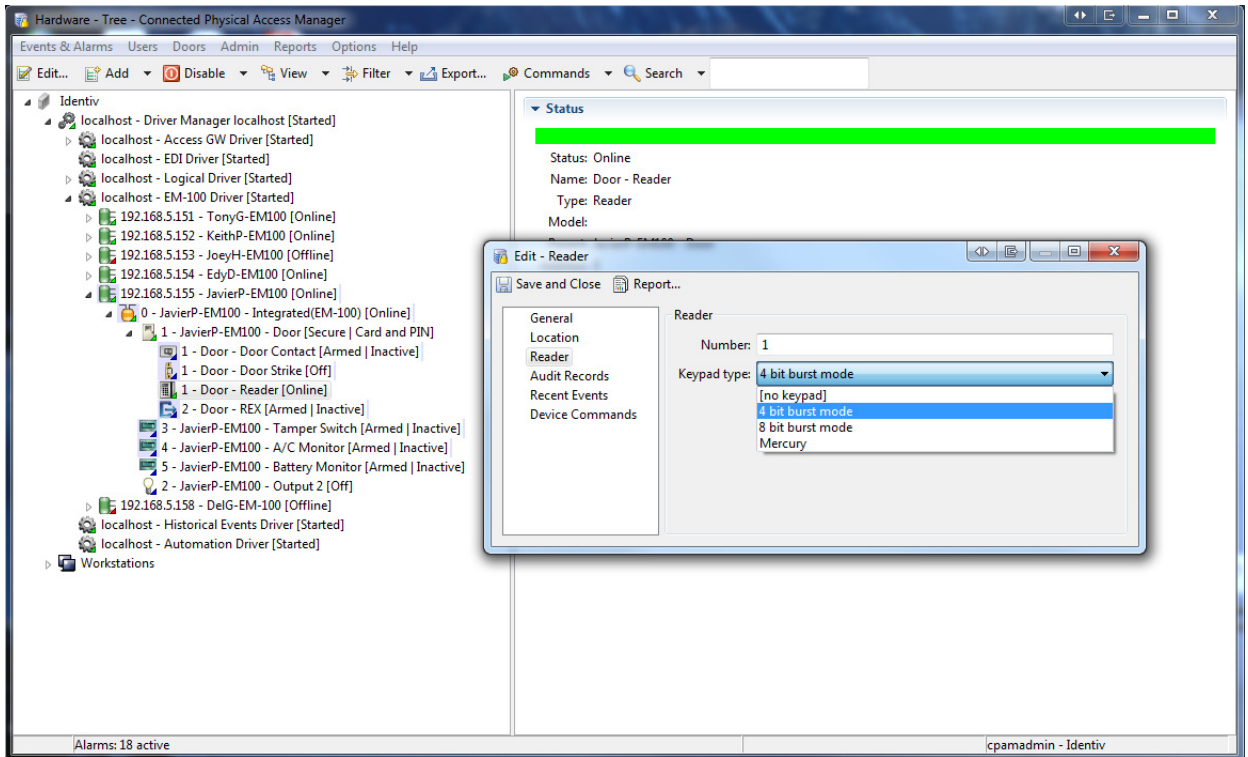

- The PIN code is specified for each badge. For example:

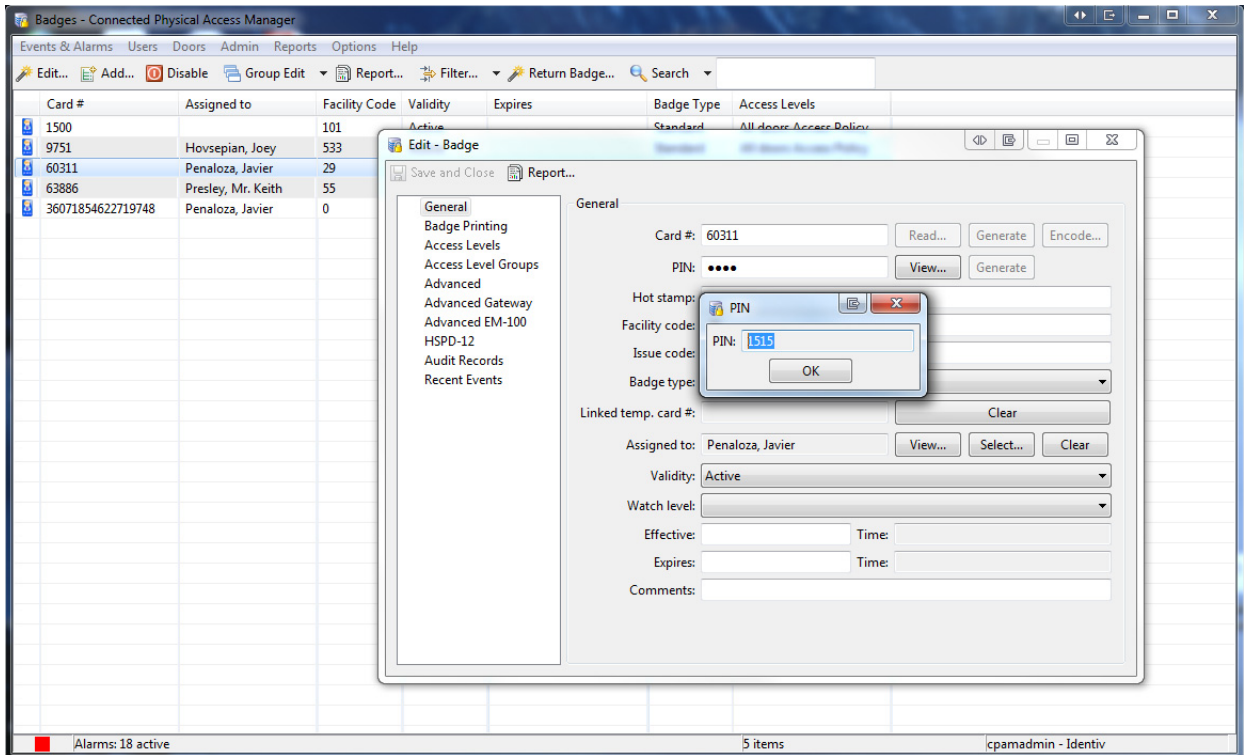

### Caution

If badges were previously created when the **Require PIN to be unique** option (located on the **Badges** page of the **System Configuration** window) was not checked, it is possible that some of those badges might have the same PIN value. Review the existing badges in your system, and if necessary, reissue some badges to ensure that each one has a unique PIN value.

After making these three configuration changes, you must perform an **Apply Configuration / Credential Changes** command at the EM-100 controller or driver level. For example:

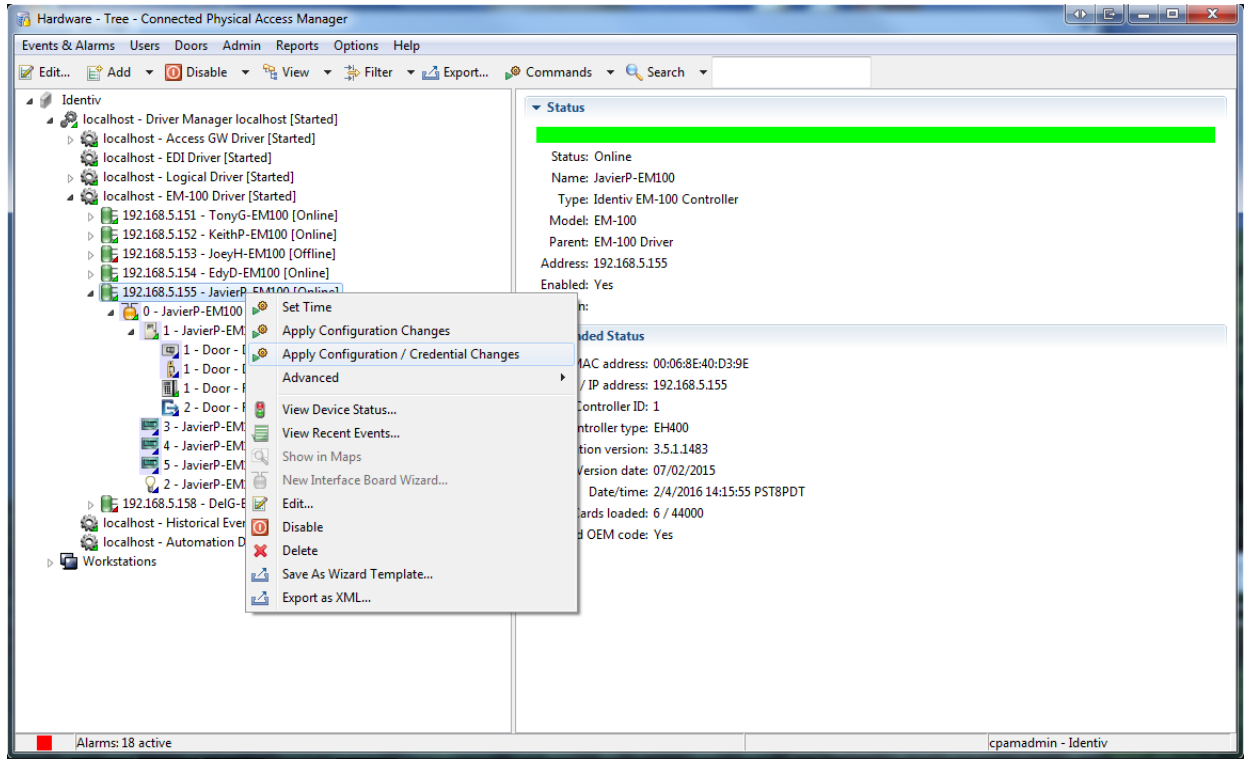

# Modifying Existing Controllers

There are two distinct types of controllers supported by ICPAM:

- Gateway controllers
- Identiv EM-100 controllers

To modify an existing controller, follow this procedure.

## Editing Gateway Controllers

- 
- Step 1** Select **Hardware Tree** or **Door/Location-based Hardware** from the **Doors** menu.
- Step 2** Right-click a gateway controller and select **Edit**.
- The gateway property sheets appear. For more on these property sheets, refer to [Gateway Controller Property Sheets, page 6-43](#).
- Step 3** Make changes to the fields on each page as required.
- Step 4** When you are finished, click **Save**.
- Step 5** Select **Apply Configuration Changes** on the GW Driver or on a specific controller. For more on this, refer to [“Applying Configuration Changes to Controllers” section on page 6-50](#).
- Note** Controllers must be in the Up state, signified by a green triangle in the icon. A dark green triangle means configuration changes that have not been applied.
- 

## Editing Identiv EM-100 Controllers

- 
- Step 1** Select **Hardware Tree** or **Door/Location-based Hardware** from the **Doors** menu.
- Step 2** Right-click a Identiv EM-100 controller and select **Edit**.
- The Identiv EM-100 controller property sheets appear. For more on this, refer to [EM-100 Controller Property Sheets, page 6-46](#).
- Step 3** Make changes to the fields on each page as required.
- Step 4** When you are finished, click **Save**.
- Step 5** Apply configuration changes using the instructions in [“Applying Configuration Changes to Controllers” section on page 6-50](#).
-



# Gateway Controller Property Sheets

When you add or edit an existing gateway controller, the gateway property sheets appear. The most important property pages and the fields on them are explained in the following subsections.

- [Gateway General Property Page, page 6-43](#)
- [Gateway Location Property Sheet, page 6-44](#)
- [Gateway Properties Property Sheet, page 6-45](#)

## Gateway General Property Page

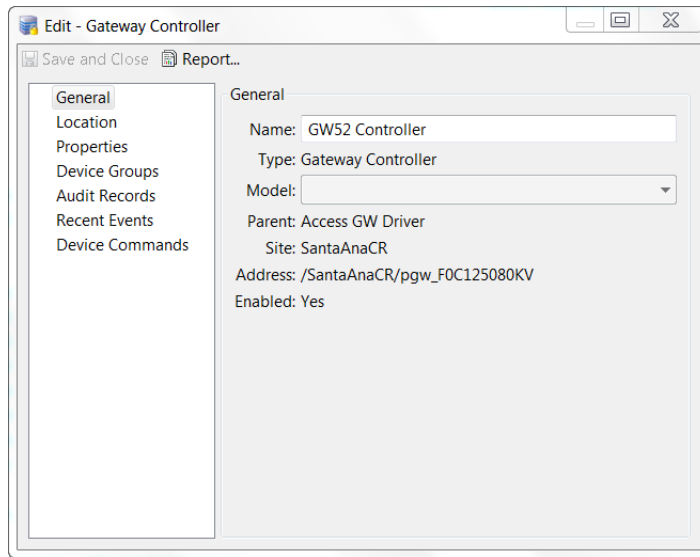

## Gateway Location Property Sheet

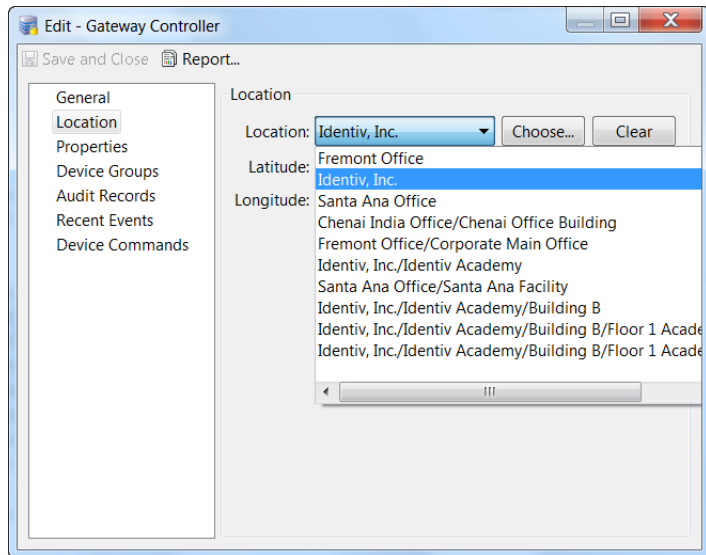

### Gateway Properties Property Sheet

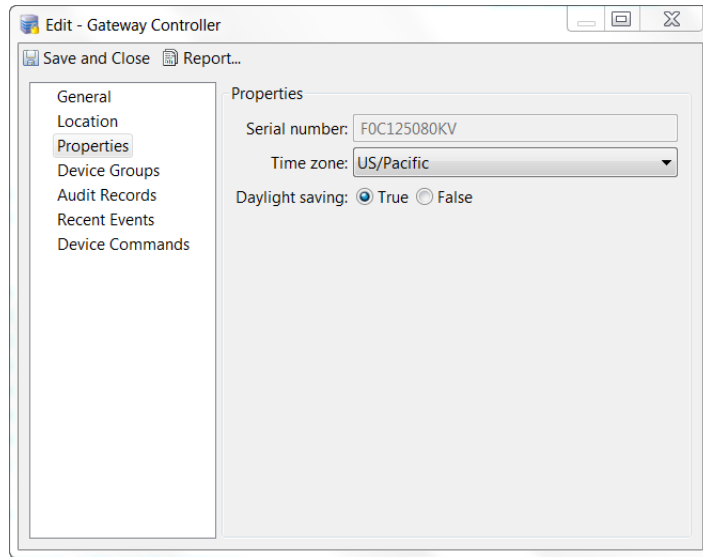

## EM-100 Controller Property Sheets

When you add or edit an existing controller, the EM-100 Controller property sheets appear. Each property page and the fields on them are explained in the following subsections.

- [Controller General Property Page, page 6-46](#)
- [Controller Location Property Page, page 6-47](#)
- [Controller Configuration Page, page 6-47](#)
- [Controller Calendar and Time Zone Page, page 6-48](#)
- [Controller Audit Records Page, page 6-49](#)
- [Controller Recent Events Page, page 6-49](#)
- [Controller Device Commands, page 6-50](#)

### Controller General Property Page

<b>Name</b>	Enter an appropriate name for this Identiv EM-100 controller.
<b>Type</b>	This read only field supplies the type for this controller.
<b>Model</b>	From the drop-down list, select the model of this EM-100. Currently, there is only one model so this field need not be used.
<b>Parent</b>	This read-only field provides the relationship of this controller to the controllers around it: parent or child.
<b>Site</b>	This read-only field is populated with the current site under which this controller appears in the Hardware Tree.
<b>Address</b>	Check the Enabled box if the address of this controller has been placed on line. Check Inherit enable/disable from parent to separate this controller from its parent controller.
<b>Comments</b>	(optional) Enter any comments describing or giving details for this controller.

## Controller Location Property Page

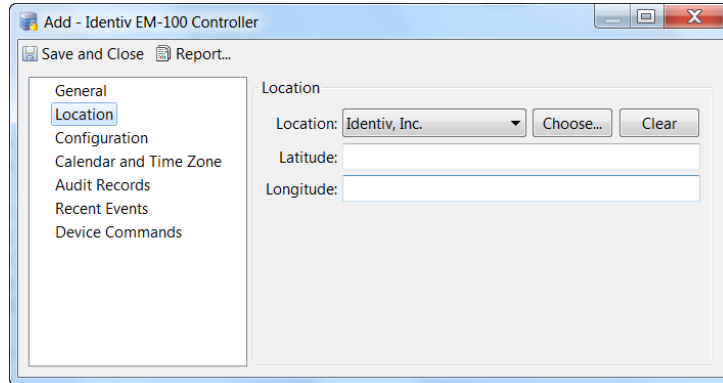

## Controller Configuration Page

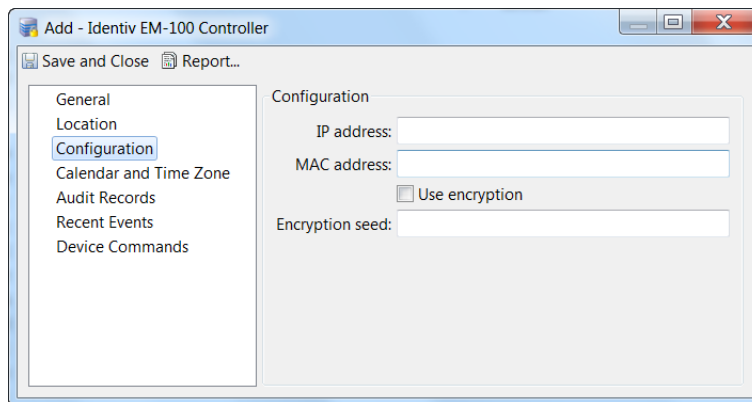

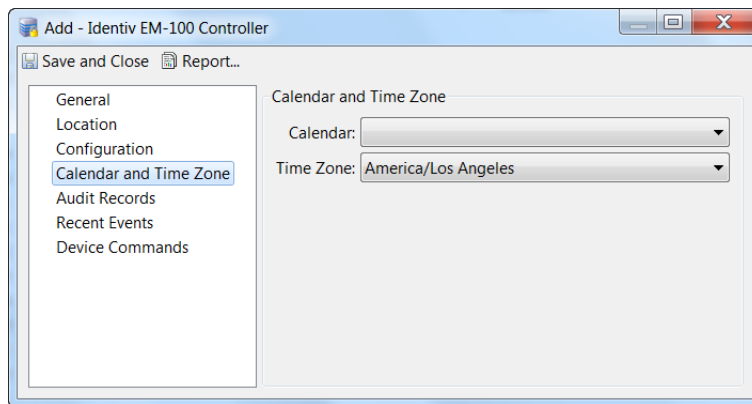

## Controller Calendar and Time Zone Page

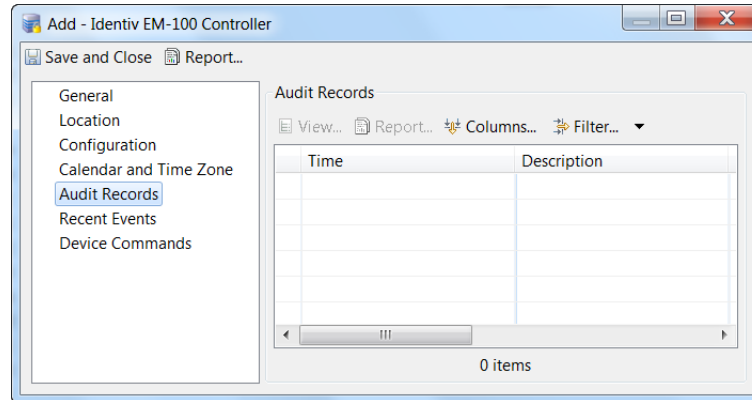

	<p>From the drop-down list, select the time zone where this controller is located.</p> <p>The Time Zone and Daylight Savings setting are not configurable if defined by the template.</p>

## Controller Audit Records Page



This table displays a list of all audit records detected for this controller. For more on this, see [Viewing Audit Records and Events for Personnel Records](#), page 9-10.

## Controller Recent Events Page

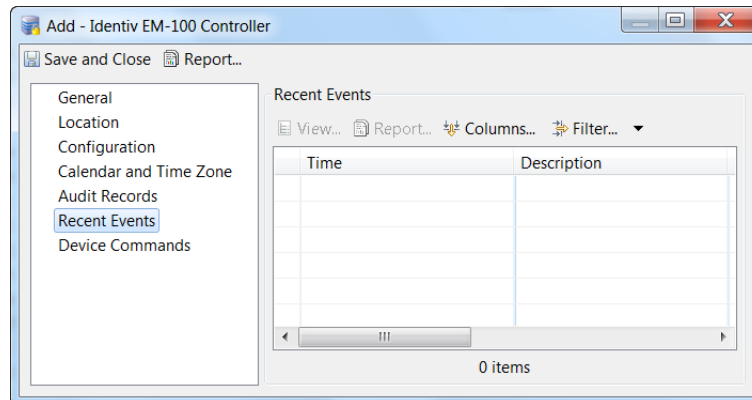

This table displays a list of all recent events recorded for this controller. See [Viewing the Recent Events for a Device or Driver](#), page 5-17.

## Controller Device Commands

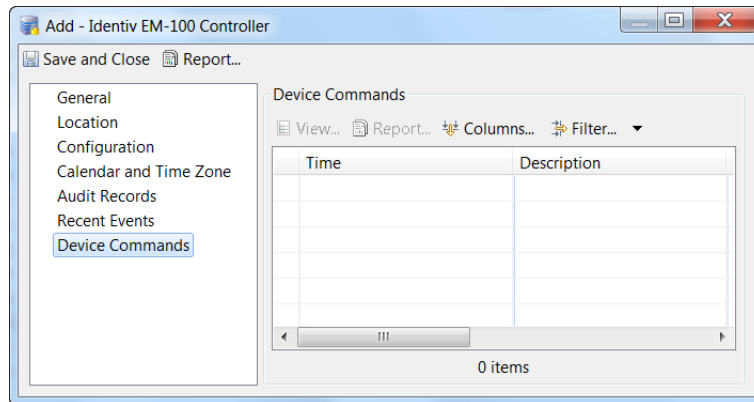

This table displays a list of all device commands associated with this controller. For more on this, see [Device Commands, page 7-46](#).

## Applying Configuration Changes

Changes made to a door or device configuration in ICPAM are inactive until applied to the controller. You can apply the configuration changes to a specific controller, to all controllers, or to all controllers in a location. Applying a configuration downloads the revised configuration file to the controller.

Controllers must be in the Up state, signified by a green triangle in the icon. A dark green triangle signifies that the controller has configuration changes that have not been applied (downloaded).

This section includes the following information.

- [Applying Configuration Changes to Controllers, page 6-50](#)
- [Configuration Management in Provisioned vs. Discovered Configurations, page 6-53](#)

## Applying Configuration Changes to Controllers

You can download the configuration to controllers using either the **Hardware Tree** or **Door/Location-based Hardware** modules.

## Applying Configuration Changes in the Hardware Tree Module

Select **Apply Configuration Changes** on the Identiv or GW Driver or on a specific controller.



- Right-click the designated driver and select **Apply Configuration Changes** to download configuration changes for all controllers.

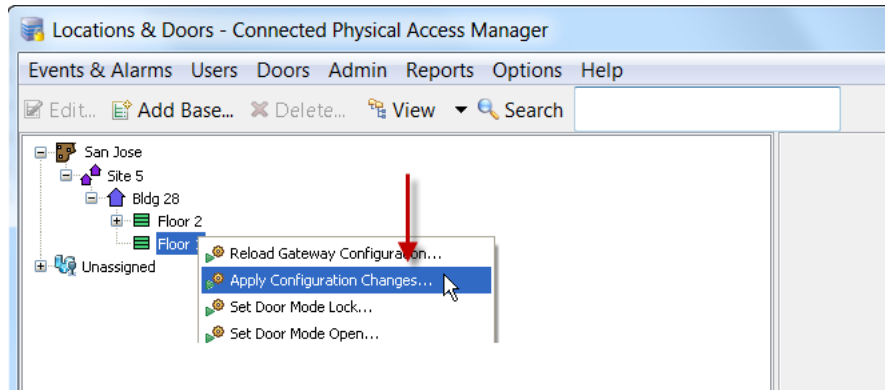

or

- Right-click on a specific controller and select **Apply Configuration Changes** to download configuration changes only to that controller.

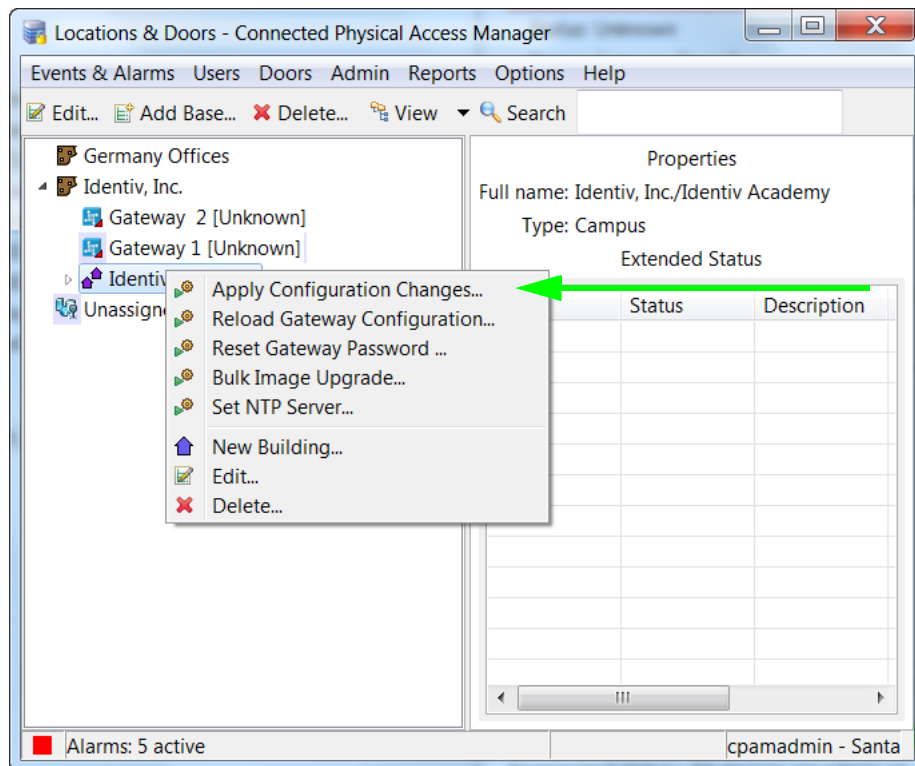

**Note** Controllers must be in the Up state, signified by a green triangle in the icon. A dark green triangle means there are configuration changes that have not been applied. See [Understanding Device Status Colors](#), page 5-15.

## Applying Configuration Changes in the Door/Location-Based Module

Select **Apply Configuration Changes** on the affected controller or on a location.

### Specific Controller:

- Select **Gateway Controllers** from the **View** menu to display the gateways.
- Right-click a controller or gateway icon and select **Apply Configuration Changes** to download the configuration for a single device.

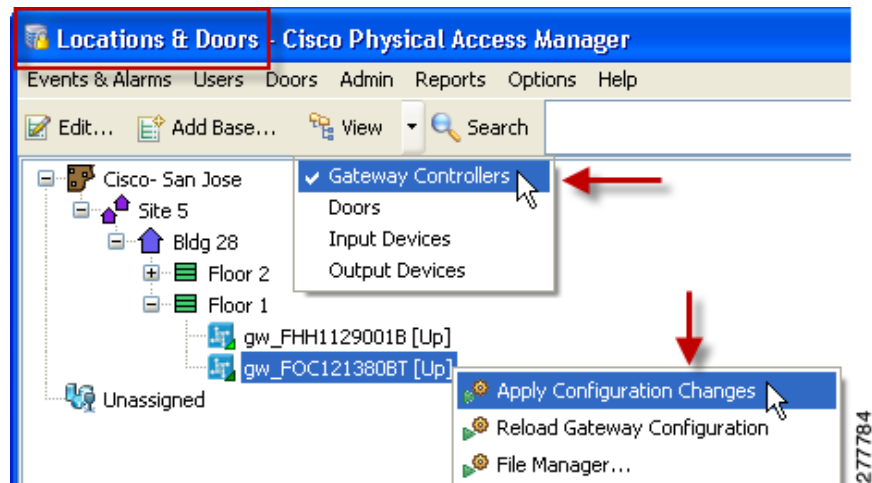

OR

### Multiple Controllers:

- Right-click a location icon.
- Select **Apply Configuration Changes**.

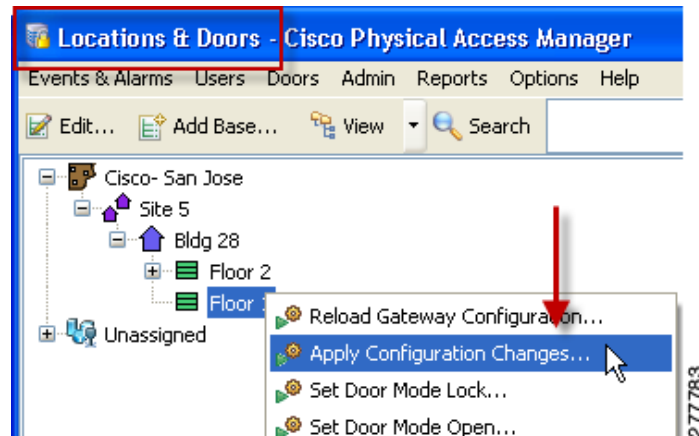

**Note** Controllers must be in the Up state, signified by a green triangle in the icon. A dark green triangle means there are configuration changes that have not been applied. See [Understanding Device Status Colors](#), page 5-15.

## Configuration Management in Provisioned vs. Discovered Configurations

- In a Provisioned configuration, the configuration is entered before the controller is brought online and the configuration is automatically downloaded when the controller is added to the network. Any subsequent configuration changes must be downloaded using one of the methods described in this section.
- In a Discovered configuration, the controller is added to the network before a configuration is created. ICPAM automatically creates a basic configuration containing the serial numbers of the controller and any expansion modules. Any subsequent configuration changes must be downloaded using one of the methods described in this section.
- If a controller power-cycles or is disconnected and reconnected to the network, the last configuration applied to the module will automatically be downloaded when the module comes online.

**Note**

See [Provisioned \(Pre-Populated\) vs. Discovered Controller Configurations, page 5-2](#) for more information.

## Cloning a Gateway Configuration

Cloning a gateway creates an exact copy of a gateway configuration, including any attached expansion modules, devices, or door configurations. Only the names, locations, and serial numbers of the devices and doors are changed in the clone. A gateway clone is an independent copy, and is used to configure one other controller. Changes to the original gateway or to the clone gateway do not effect each other.

**Note**

Cloning can only be done with gateway controllers. Identiv EM-100 controllers do not yet support cloning.

To create a gateway clone, do the following:

- Step 1** Select **Hardware Tree** or **Door/Location-based Hardware** from the **Doors** menu.
- Step 2** Right-click a gateway controller and select **Clone Gateway**.
- Step 3** Enter the names, serial numbers, and locations for the clone gateway. For expansion modules, note the type of expansion module that each serial number is assigned to, and match it to the same type of module for the clone configuration.
- Step 4** (Optional) Click **Clone all module names** to use the source names for the clone configuration.
- Step 5** Click **OK**.
- Step 6** Right-click the gateway icon and select **Reload Gateway Configuration**. This command downloads the full configuration and replaces the existing file on the specified gateway. The gateway must be installed and in the Up state, or the reload will fail.
- Step 7** Add doors or revise the configuration as necessary. See [Adding New Doors, page 7-2](#) for more information.

Figure 6-3 Clone Gateway

	Gateway	Clone Gateway
Gateway name:	Gateway 2	
Gateway serial number:	F0C151280C8	
Gateway location:	Identiv, Inc.	
Module serial number:	F0C151280C8	
Door name:	Gateway Door 2	
Door location:	Identiv, Inc.	
<input type="checkbox"/> Clone all module names		
		OK Cancel



Tip

To create a template from a gateway configuration, see [Creating Custom Gateway Configurations without Templates](#), page 6-2.

## Replacing a Gateway



Note

Replacement can only be done with Gateway controllers. Identiv EM-100 controllers do not yet support this feature.

To replace a gateway with a new device, complete the following instructions.



Note

The replacement module must be the same as the old module, and all device connections must be the same. All configurations and properties remain the same.

- Step 1** Physically remove the old device. ICPAM automatically detects the removal and disables the device configuration.
- Step 2** In the **Hardware Tree** module, select **All Devices** from the **Filter** menu to display the disabled device.
- Step 3** Right-click the device icon and select **Replace Gateway** or **Replace Module**. These commands are enabled only after a device is disconnected.

- Step 4** Enter the serial ID (number) of the replacement device and click **OK**.

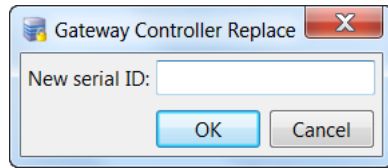

- Step 5** Physically install the replacement gateway or expansion module.



**Tip** Connect expansion modules to the same gateway interface. The gateway automatically recognizes the new module, and enables the device in ICPAM.

- Step 6** Right-click on the gateway icon and select **Reload Gateway Configuration**. This command downloads the correct (full) configuration to the gateway.

## Deleting a Controller

To delete a controller, do the following:

- Step 1** Enable the Delete functions, as described in [Enabling the Delete Options, page 7-18](#).
- Step 2** Disable all devices in all doors associated with the Controller, as described in [Disabling or Deleting a Door, page 7-16](#).
- Step 3** Select **All Devices** from the **Filter** menu to display the disabled device(s).
- Step 4** Delete the controller by right-clicking the Controller and selecting **Delete**.
- Step 5** Select **Yes** to confirm.
- Step 6** Download the changes to the controller, as described in [For more on this process, see Applying Configuration Changes to Controllers, page 6-50](#).

## Changing Gateway Passwords

You can change the password for one or more Gateways in the **Hardware Tree** module, or the **Door/Location-based Hardware** module.



**Note** This feature is not supported by the Identiv EM-100 controller.

- Step 1** Display the gateway or controller:
- Select **Door/Location-based Hardware** from the **Doors** menu and select **Gateway Controllers** from the **View** menu.
- or

- Select **Hardware Tree** from the **Doors** menu and expand the Access GW Driver device tree.
- Step 2** Change the password for one or more gateways:
- To change the password for a single device, right-click a Gateway icon and select **Reset Gateway Password**.
  - To change the password for a multiple devices, right-click the location icon or the Access GW Driver and select **Reset Gateway Password**. Changing the password for a location affects only the gateways at that location. Changing the password for the driver affects all the gateways in the system.

See [Figure 6-4](#) and [Figure 6-5](#) for examples to change the gateway passwords.

**Figure 6-4** Reset Gateway Password from Door/Location-based Hardware

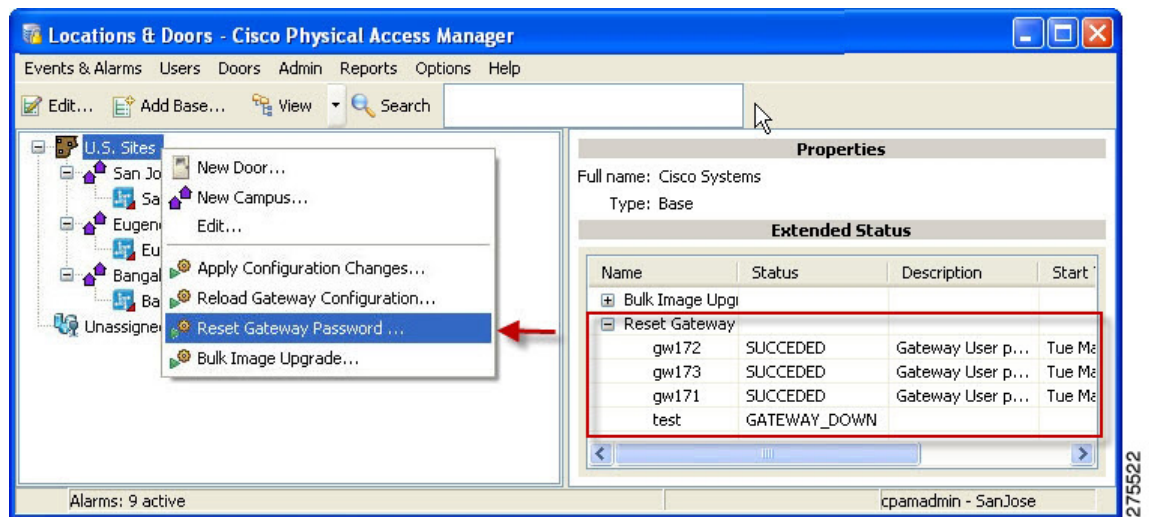
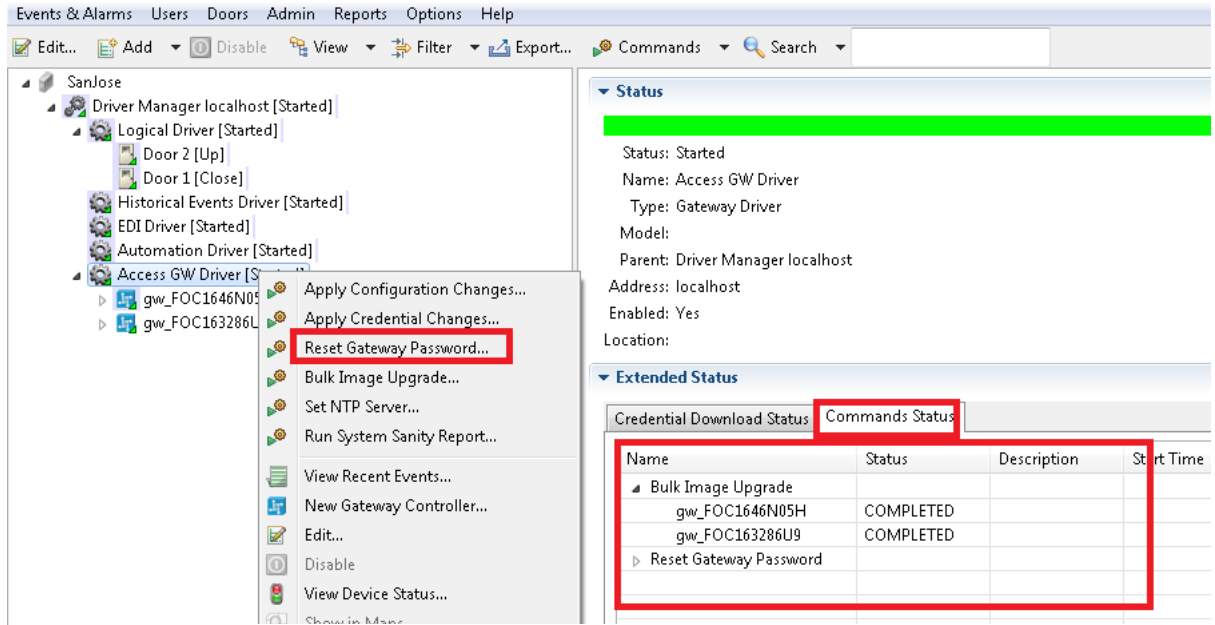
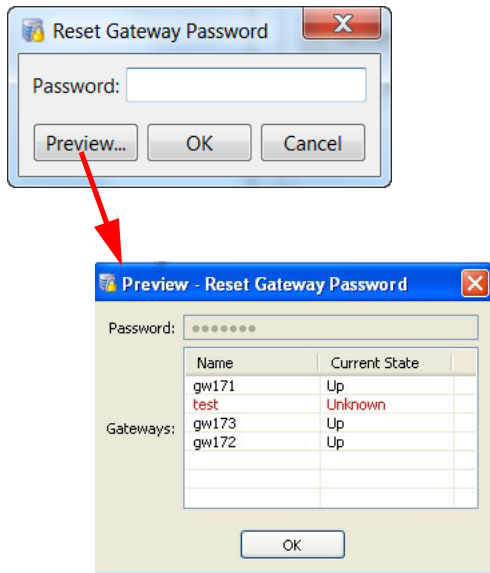

Figure 6-5 Reset Gateway Password from Hardware Tree



- Step 3 (Optional) In the Reset Gateway Password window (Figure 6-6), click **Preview** to view a list of Gateways. Gateways must be in the **Up** or **Down** state. If a Gateway is in the **Unknown** state, the device is displayed in red and the password is not changed.
- Step 4 Enter a new password and click **OK** (Figure 6-6).

Figure 6-6 Enter a Gateway Password



- Step 5 Verify the status of the change:
  - In the **Door/Location-based Hardware** module, select a location. The command status is displayed under Extended Status in the lower right of the screen (see Figure 6-4 on page 6-56).

- In the **Hardware Tree** module, select the required Access GW Driver. Select the Command Status tab under Extended Status in the lower right of the screen (see [Figure 6-4 on page 6-56](#)).

**Tip**

To change gateway settings using a direct PC connection, you must connect a PC to the module and enter a password, as described in the *Cisco Physical Access Gateway User Guide*.

## Modifying Driver Configurations

The ICPAM system tree includes many drivers that are installed during setup and configuration. These include the GW Driver and the Identiv EM-100 Driver that can be configured to provide a custom environment for the controllers and devices that are subordinate to them.

- [Editing Identiv EM-100 Controllers, page 6-42](#)
- [Modifying GW Drivers, page 6-58](#)

## Modifying GW Drivers

- 
- Step 1** Select **Hardware Tree** or **Door/Location-based Hardware** from the **Doors** menu.
  - Step 2** Right-click a Access GW driver and select **Edit**.  
The Edit Gateway driver property sheets appear. For more on these sheets, see [Access GW Driver Property Sheets, page 6-59](#).
  - Step 3** Make changes to the fields on each page as required.
  - Step 4** When you are finished, click **Save**.
  - Step 5** Select **Apply Configuration Changes** on the Identiv Driver or on a specific controller.
- 

## Modifying Identiv EM-100 Drivers

- 
- Step 1** Select **Hardware Tree** or **Door/Location-based Hardware** from the **Doors** menu.
  - Step 2** Right-click a Identiv driver and select **Edit**.  
The Edit Identiv Driver property sheets appear. For more on these sheets, see [Identiv EM-100 Driver Property Sheets, page 6-62](#).
  - Step 3** Make changes to the fields on each page as required.
  - Step 4** When you are finished, click **Save**.
  - Step 5** Select **Apply Configuration Changes** on the Identiv Driver or on a specific controller.
-



## Access GW Driver Property Sheets

When you select **Edit** from the Access GW Driver option list, a multi-page property sheet appears. Each of these pages and the fields that appear on them are explained on the following pages.

- [Gateway Driver General Page, page 6-59](#)
- [Gateway Driver Location Property Page, page 6-60](#)
- [Gateway Driver Configuration Property Page, page 6-61](#)
- [Gateway Driver Recent Events Property Sheet, page 6-61](#)

### Gateway Driver General Page

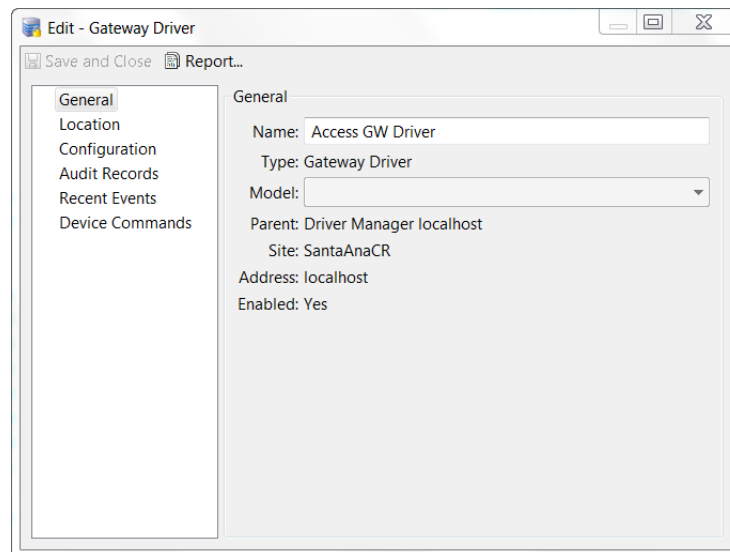

<b>Name</b>	Enter an appropriate name for this Access GW driver.
<b>Type</b>	This read only field supplies the type for this driver.
<b>Model</b>	From the drop-down list, select the model of this driver. Currently, there is only one driver model so this field need not be used.
<b>Parent</b>	This read-only field provides the relationship of this driver to other drivers: parent or child.
<b>Site</b>	This read-only field is populated with the current site under which this driver appears in the Hardware Tree.
<b>Address</b>	This read-only field indicates the address of the driver.
<b>Enabled</b>	This read-only field indicates whether this driver is enabled or disabled.

## Gateway Driver Location Property Page

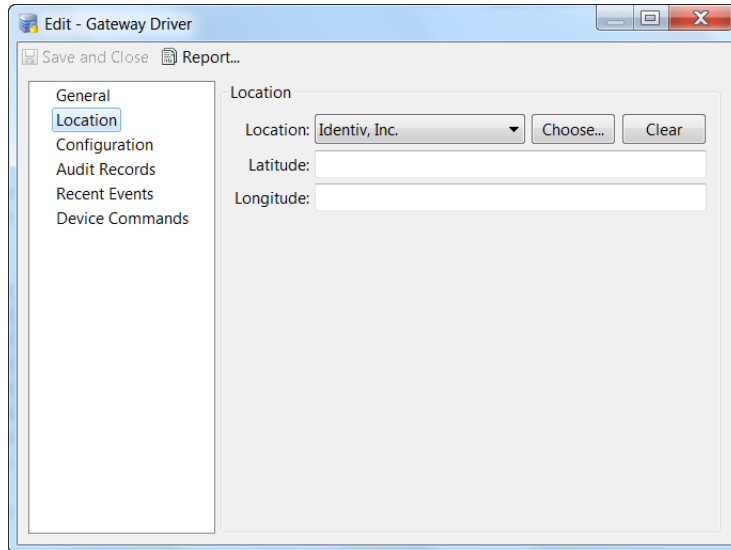

### Gateway Driver Configuration Property Page

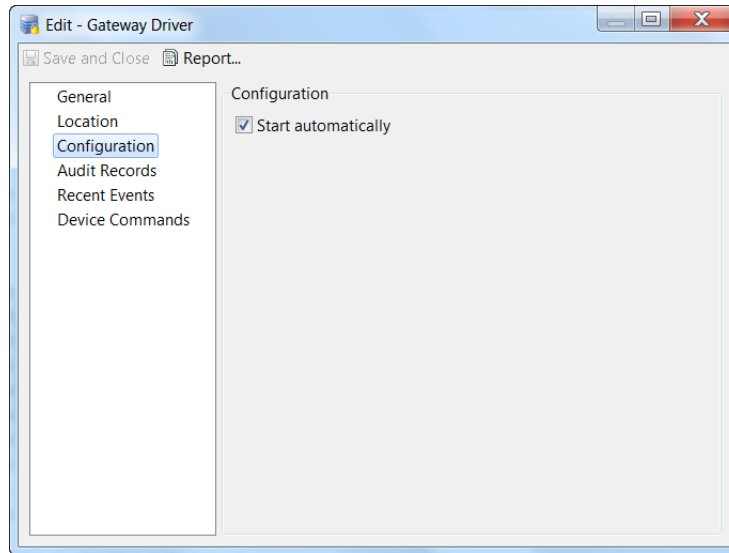

### Gateway Driver Recent Events Property Sheet

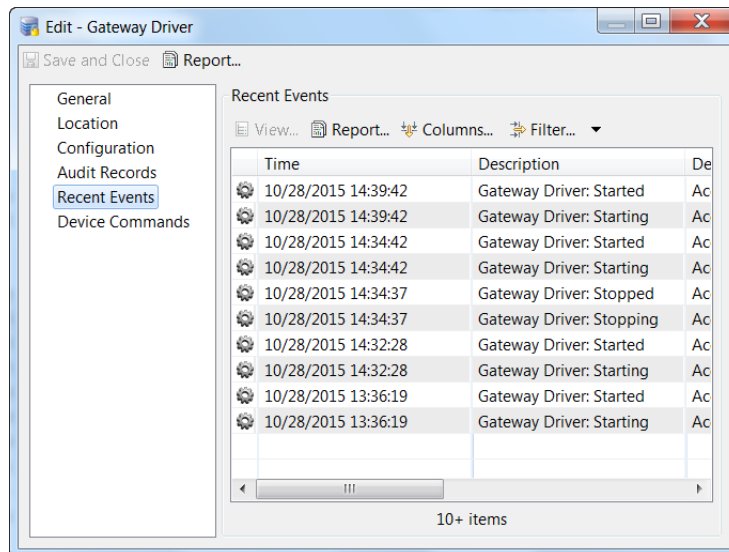

This table displays a list of all recent events recorded for this driver. See [Viewing the Recent Events for a Device or Driver](#), page 5-17.

## Identiv EM-100 Driver Property Sheets

When you select **Edit** from the Identiv EM-100 Driver option list, a multi-page property sheet appears. Each of these pages and the fields that appear on them are explained on the following pages.

- [Driver General Page, page 6-62](#)
- [Driver Location Property Page, page 6-63](#)
- [Driver Configuration Page, page 6-64](#)
- [Driver EM-100 Credential Templates Page, page 6-65](#)
- [Driver Input Supervision Page, page 6-66](#)
- [Driver Audit Records Page, page 6-66](#)
- [Driver Recent Events Page, page 6-67](#)

### Driver General Page

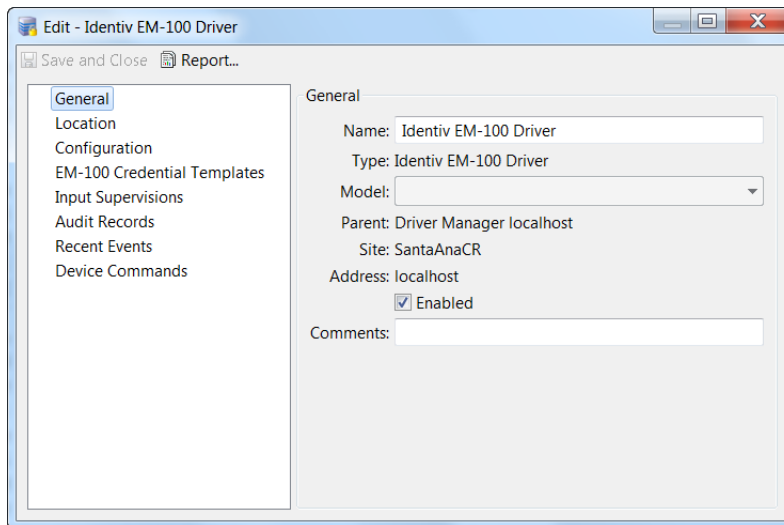

<b>Name</b>	Enter an appropriate name for this Identiv EM-100 driver.
<b>Type</b>	This read only field supplies the type for this driver.
<b>Model</b>	From the drop-down list, select the model of this EM-100 driver. Currently, there is only one driver model so this field need not be used.
<b>Parent</b>	This read-only field provides the relationship of this driver to other drivers: parent or child.
<b>Site</b>	This read-only field is populated with the current site under which this driver appears in the Hardware Tree.
<b>Address</b>	Check the Enabled box if the address of this driver has been placed on line.
<b>Comments</b>	(optional) Enter any comments describing or giving details for this driver.

### Driver Location Property Page

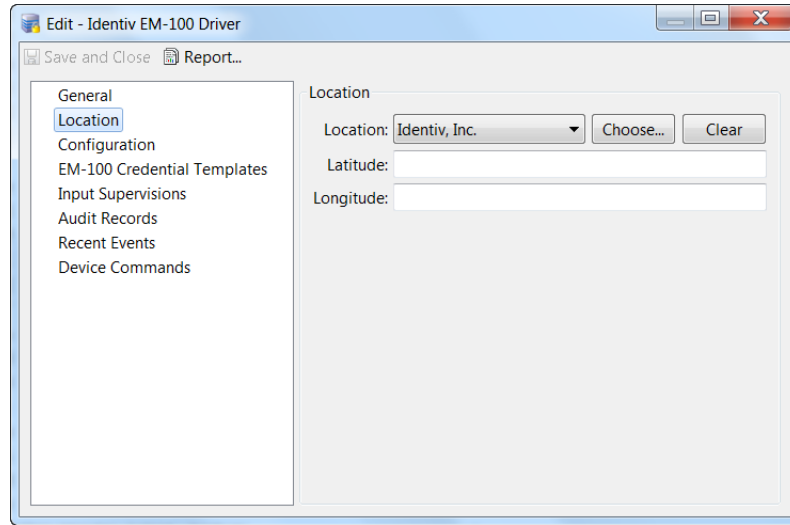

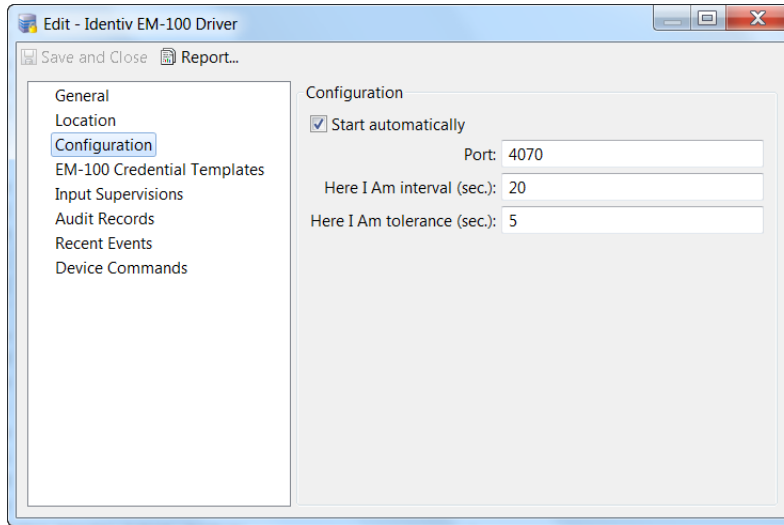

## Driver Configuration Page

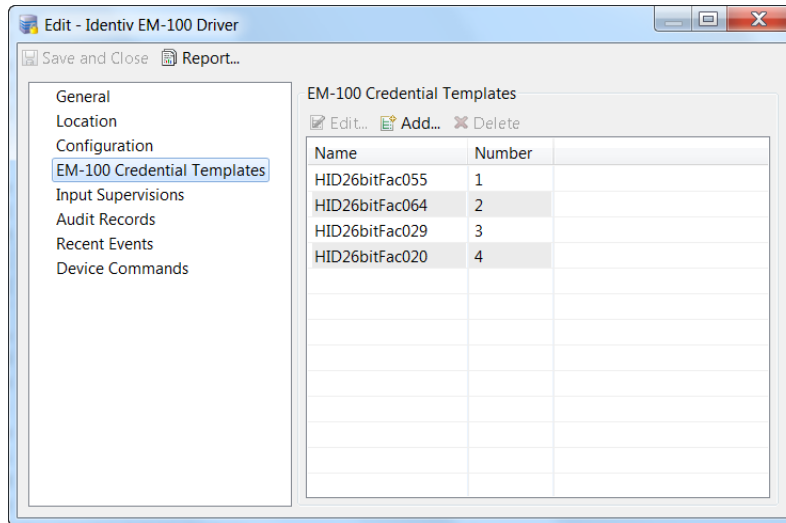

## Driver EM-100 Credential Templates Page

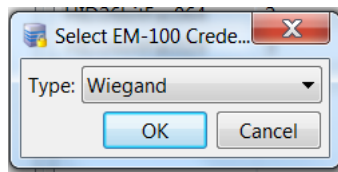

The table on this page indicates the Credential Templates that are already defined for this driver. To add a new template, click **Add...** then enter the name of the new credential template in the Select EM-100 Credential dialog box.



For more on creating credential templates, see [Creating a Virtual Credential Template, page 8-20](#).

To edit an existing template, click to highlight one of the templates in the table then click **Edit...**

To remove one of the templates already assigned to this driver, click to highlight one of the templates from the table, then click **Delete**.

For more on defining credential templates, refer to [Creating a Virtual Credential Template, page 8-20](#).

## Driver Input Supervision Page

Compatibility	Name	Number	Inactive ...	Inactive ...	Active R...	Active R...
EM-100	Normally closed, n...	2	196	0	255	197
EM-100	Normally open, no ...	1	255	197	196	0
EM-100	Standard EOL, 1K n...	3	180	159	215	181
EM-100	Standard EOL, 2K n...	4	215	181	180	159
EM-100	Standard EOL, 2K n...	5	196	159	215	197
EM-100	Standard EOL, 4K n...	6	215	197	196	159
Unsupported	Normally closed, n...	8	128	0	255	129
Unsupported	Normally open, no ...	7	255	129	128	0
Unsupported	Standard EOL, 1K n...	9	89	80	133	120
Unsupported	Standard EOL, 2K n...	10	133	120	89	80
Unsupported	Standard EOL, 2K n...	11	131	118	172	155
Unsupported	Standard EOL, 4K n...	12	175	158	132	119

The table on this page lists all input supervisions currently supported by this driver.

To add a new supervision, click **Add...** and make changes as required on the property sheet to define a new input supervision model. For more on this, refer to [Device Configuration Properties](#), page 8-30.

## Driver Audit Records Page

Time	Description
10/22/2015 16:42:08	Device record updated
10/21/2015 15:18:26	Device record updated
10/21/2015 15:14:54	Device record updated
10/21/2015 12:11:48	Device record updated
10/20/2015 20:16:36	Device record updated
10/18/2015 09:39:02	Device record updated
10/18/2015 09:35:14	Device record updated
10/16/2015 09:49:47	Device record updated
10/14/2015 10:30:51	Device record updated
10/14/2015 10:28:55	Device record updated

10+ items

The table on this page displays a list of all audit records detected for this driver. For more on this, see [Viewing Audit Records and Events for Personnel Records](#), page 9-10.



## Driver Recent Events Page

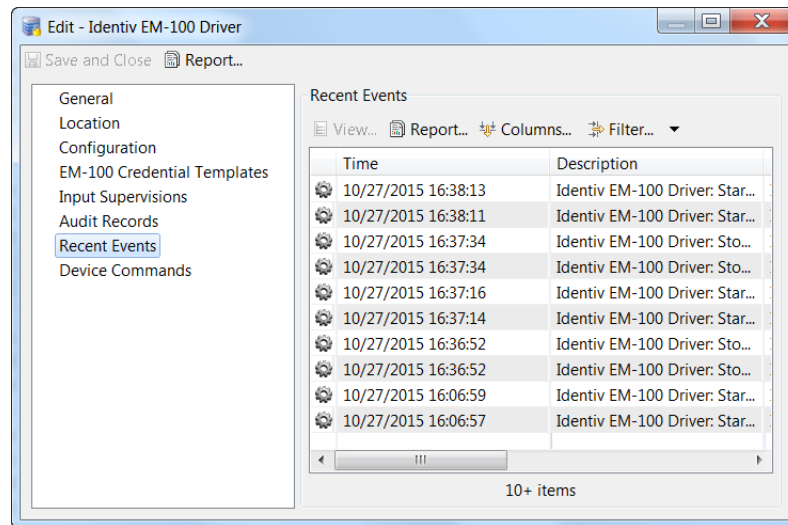

The table on this page displays a list of all recent events recorded for this driver. See [Viewing the Recent Events for a Device or Driver, page 5-17](#).

# Controller and Driver Commands

To access the following commands, right-click on the driver or controller icon in the Hardware Tree module (select **Hardware Tree** from the **Doors** menu).

- [Access GW Driver Commands, page 6-68](#)
- [Gateway Controller Commands, page 6-69](#)
- [Physical Driver Commands, page 6-71](#)
- [Identiv EM-100 Driver Commands, page 6-71](#)

## Access GW Driver Commands

*Table 6-1 Access GW Driver Commands*

Command	Description
Apply Configuration Changes	Downloads configuration changes to all gateways. Changes made in ICPAM are inactive until applied with this command. See <a href="#">Applying Configuration Changes, page 6-50</a> .
Apply Credential Changes	Downloads credential changes to all gateways. Credential changes made in ICPAM are downloaded every 60 minutes by default, and are inactive until then. Use the Apply Credential Changes command to download the credential configuration to all gateways immediately. See <a href="#">Downloading Credential Changes to the Controllers, page 9-9</a> .
Reset Gateway Password	Resets the password on all configured gateways. See <a href="#">Changing Gateway Passwords, page 6-55</a> .
Bulk Image Upgrade	Downloads a firmware image to all gateways. See <a href="#">Upgrading Gateway Firmware Images Using ICPAM, page C-11</a> .
Set NTP Server	Sets the Network Time Protocol (NTP) server for one or more gateways. See <a href="#">Changing the NTP Setting for Multiple Gateways, page C-6</a> .
Run System Sanity Report	Creates a snapshot of potential inconsistencies in the system. See <a href="#">Generating a Gateway Driver System Sanity Report, page 5-18</a> .
View Recent Events	View a list of recent events for all gateways. See <a href="#">Viewing the Recent Events for a Device or Driver, page 5-17</a> .
New Gateway Controller	Creates a gateway configuration entry. See <a href="#">Creating Custom Gateway Configurations without Templates, page 6-2</a> .
Edit	Opens the Edit window to revise the driver properties.
Disable	Disables all gateways, attached devices, and door configurations. See <a href="#">Disabling or Deleting a Door, page 7-16</a> . Disabled Devices can be re-enabled.
Delete	Permanently removes the gateways and attached devices from the configuration. See <a href="#">Disabling or Deleting a Door, page 7-16</a> .

Table 6-1 Access GW Driver Commands (continued)

Command	Description
View Device Status	Opens a new window containing the Status and Extended Status information. See <a href="#">Viewing Device and Door Status, page 5-11</a> .
Show in Graphic Map Editor	Allows operators to add facility maps, and plot and organize devices for use in the Map viewer module. See <a href="#">Map Editor, page 12-55</a> .

## Gateway Controller Commands

Table 6-2 Gateway Controller Commands

Command	Description
Apply Configuration Changes	Downloads configuration changes to the specified controller. Changes made in ICPAM are inactive until applied with this command.  <b>Note</b> Gateways must be in the Up state, signified by a green triangle in the icon. A dark green triangle means configuration changes that have not been applied. For more information, see <a href="#">Applying Configuration Changes to Controllers, page 6-50</a> .
Reload Gateway Configuration	Downloads the full configuration and replaces the existing file on the specified Gateway. The gateway must be installed and in the Up state, or the reload will fail.
File Manager	Provides info of various files available on the gateway: <ul style="list-style-type: none"> <li>• <b>Images:</b> Set of firmware images available on the gateway including status. See <a href="#">Upgrading Gateway Firmware Images Using ICPAM, page C-11</a> for more info.</li> <li>• <b>Core Files:</b> Core files for any core dumps that occurred on the Gateway.</li> <li>• <b>Log File:</b> List of debug log files.</li> <li>• <b>Technical Summary:</b> Technical data to assist in debugging issues.</li> </ul> <b>Note</b> Each screen also provides options to download or upload the files.
Save As Gateway Template	Saves the gateway configuration as a template that can be used to configure additional devices. See <a href="#">Creating Custom Gateway Configurations without Templates, page 6-2</a> and <a href="#">Gateway Templates, page 5-26</a> .
Clone Gateway	Creates an exact duplicate of a gateway configuration. See <a href="#">Cloning a Gateway Configuration, page 6-53</a> .
Reset Gateway	Performs a soft reset of the gateway. See the <i>Cisco Physical Access Gateway User Guide</i> for more details.

Table 6-2 Gateway Controller Commands (continued)

Command	Description
Set Gateway Address	<p>Replaces the gateway network configuration.</p> <p><b>Note</b> The gateway network settings can also be configured using a direct connection to the Gateway. See the <i>Cisco Physical Access Gateway User Guide</i>.</p> <p>If this command is used to enter the gateway network configuration, all settings on the gateway are replaced. You <b>cannot</b> use this command to modify only selected parameters.</p> <p>To view the current settings, select the gateway in the Hardware Tree module. In the Extended Status screen (bottom right window), select the <b>Gateway Network Address</b> tab.</p>
Format Gateway Flash	Erases and formats the gateway flash memory.
Replace Gateway	Replaces the current gateway with new gateway device. This command is active only when the device is disconnected from ICPAM (Unknown State). The command is used to replace a faulty device. See <a href="#">Replacing a Gateway, page 6-54</a> .
Reset Gateway Password	Resets the password for the selected gateway device. You can also reset the passwords for multiple gateways. See <a href="#">Changing Gateway Passwords, page 6-55</a> .
Download All Credentials	Downloads all credentials to the gateway to ensure all required data is correct. This command should be used only if a problem exists.
Credential Look up	Search for credentials on a gateway.
View Recent Events	View a list of recent events for the gateway. See <a href="#">Viewing the Recent Events for a Device or Driver, page 5-17</a> .
New Module	Adds a new expansion module to the gateway configuration.
Edit	Opens the Edit window to revise the device properties.
Disable	Disables the device and all attached devices. Also disables any door configurations. See <a href="#">Disabling or Deleting a Door, page 7-16</a> . Disabled devices can be re-enabled.
Delete	Permanently removes the device and all attached devices from the configuration. See <a href="#">Disabling or Deleting a Door, page 7-16</a> .
View Device Status	Opens a new window containing the Status and Extended Status information.
Show in Graphic Map Editor	Allows operators to add facility maps, and plot and organize devices for use in the Map Viewer module. See <a href="#">Map Editor, page 12-55</a> .

## Physical Driver Commands

To access the following commands, right-click on the Physical Driver icon in the Hardware Tree view.

**Table 6-3** *Physical Driver Commands*

Command	Description
View Recent Events	View a list of recent events for the configured doors. See <a href="#">Viewing the Recent Events for a Device or Driver, page 5-17</a> .
New Door	Creates a new door configuration. See <a href="#">Adding New Doors, page 7-2</a> .
Edit	Opens the Edit window to revise the driver properties.
Disable	Disables the device and all attached devices. See <a href="#">Disabling or Deleting a Door, page 7-16</a> . Disabled Devices can be re-enabled.
Delete	Permanently removes the device and all attached devices from the configuration. See <a href="#">Disabling or Deleting a Door, page 7-16</a> .
View Device Status	Opens a new window containing the Status and Extended Status information.
Show in Graphic Map Editor	Allows operators to add facility maps and plot and organize devices for use in the Map viewer module. See <a href="#">Map Editor, page 12-55</a> .



**Note**

If you run any gateway commands or door commands in the Door/Location-based Hardware module, all the related events are populated as Physical Driver commands.

## Identiv EM-100 Driver Commands

To access the following commands, right-click on the Identiv EM-100 Driver icon in the Hardware Tree view.

**Table 6-4** *Identiv EM-100 Driver Commands*

Command	Description
Start	
Stop	
Restart	Restarts the Identiv EM-100 Driver, which is required after certain types of changes (such as adding a new controller).
Apply Configuration Changes...	Downloads configuration changes to the specified EM-100 controller, which must be online. (Changes made in ICPAM are inactive until applied with this command.) For more information, see <a href="#">Applying Configuration Changes to Controllers, page 6-50</a> .
Apply Configuration / Credential Changes...	Downloads configuration and credential changes to the specified EM-100 controller, which must be online. (Changes made in ICPAM are inactive until applied with this command.)

Table 6-4 Identiv EM-100 Driver Commands (continued)

Command	Description
Reset All Card Holder Status	Resets the status of all card holders at online EM-100 controllers, which can be helpful when resetting anti-passback areas after an emergency evacuation. See <a href="#">Resetting the Status of All Card Holders (at Online EM-100 Controllers)</a> , page 11-29.
Set Time	
View Device Status...	Opens a new window containing the Status and Extended Status information.
View Recent Events...	View a list of recent events for the configured doors. See <a href="#">Viewing the Recent Events for a Device or Driver</a> , page 5-17.
Show in Maps	Allows operators to add facility maps and plot and organize devices for use in the Map viewer module. See <a href="#">Map Editor</a> , page 12-55.
New Identiv EM-100 Controller Wizard...	Opens a wizard for adding a new Identiv EM-100 controller. See <a href="#">Configuring EM-100 Controllers Using Existing Templates</a> , page 6-18.
Edit...	Opens the Edit window to revise the driver properties.  The Identiv edit window includes the pages described in <a href="#">Identiv EM-100 Driver Property Sheets</a> , page 6-62.
Disable	Disables the device and all attached devices. See <a href="#">Disabling or Deleting a Door</a> , page 7-16. Disabled Devices can be re-enabled.
Export as XML...	

# Configuring Doors

---

A door configuration is a set of device hardware, such as locks and readers, assigned to a controller's interfaces. This chapter includes instructions to create and modify door configurations assigned to controller interfaces.

**Tip**

---

You can create the door configuration before the related Gateway is physically installed and added to the network. See [Provisioned \(Pre-Populated\) vs. Discovered Controller Configurations, page 5-2](#) for more information.

---

**Contents**

- [Adding New Doors, page 7-2](#)
  - [Adding Custom Doors, page 7-2](#)
  - [Adding Doors Using Door Templates, page 7-3](#)
- [Modifying Door Configurations, page 7-11](#)
- [Applying Configuration Changes, page 7-14](#)
- [Disabling or Deleting a Door, page 7-16](#)
- [Configuring Device Groups, page 7-24](#)
- [Door Property Sheets, page 7-31](#)
- [Device Commands, page 7-46](#)
- [Door Modes, page 7-47](#)
- [Door Commands, page 7-48](#)

## Adding New Doors

This section includes the following information.

- [Adding Custom Doors, page 7-2](#)
- [Adding Doors Using Door Templates, page 7-3](#)

## Adding Custom Doors

Complete the following instructions to add a door.

- 
- Step 1** Verify that the gateway for the door configuration exists in the Hardware Tree module.
- Step 2** Right-click on the required driver, and from the drop-down menu, select the **New Door...** option.
- Step 3** Select a name and location for this new door.
- Step 4** Apply the door configuration changes.

In the Door/Location-based Hardware module, right-click a location and select **Apply Configuration Changes**. Only gateways in the Up state are updated.

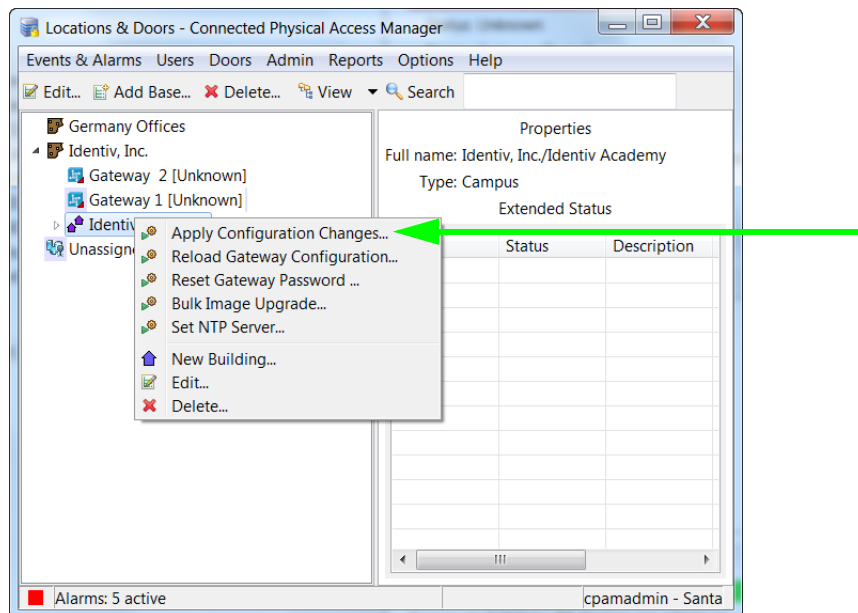

- Step 5** After the door appears, right-click on it and select **Edit**.
- The Door Edit property sheets appear as described in [Door Property Sheets, page 7-31](#).
- Step 6** Make changes to the properties on these pages as required.
-



## Adding Doors Using Door Templates

Complete the following instructions to add a door using a door template. You can accept the default configurations included in the door template, or override most settings.



**Note** This procedure describes adding doors to a gateway.

**Step 1** Verify that the gateway for the door configuration exists in the Hardware Tree module.

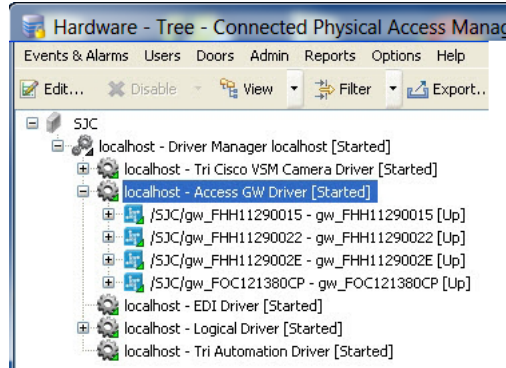

If the gateway is not already configured, use one of the following methods:

- [Creating Custom Gateway Configurations without Templates, page 6-2](#)
- [Configuring Gateways Using Existing Templates, page 6-7](#)

**Note** See also [Provisioned \(Pre-Populated\) vs. Discovered Controller Configurations, page 5-2](#).

**Step 2** Create a new door:

- Select **Door/Location-based Hardware** from the Doors menu.
- Right-click a location and select **New Door**.

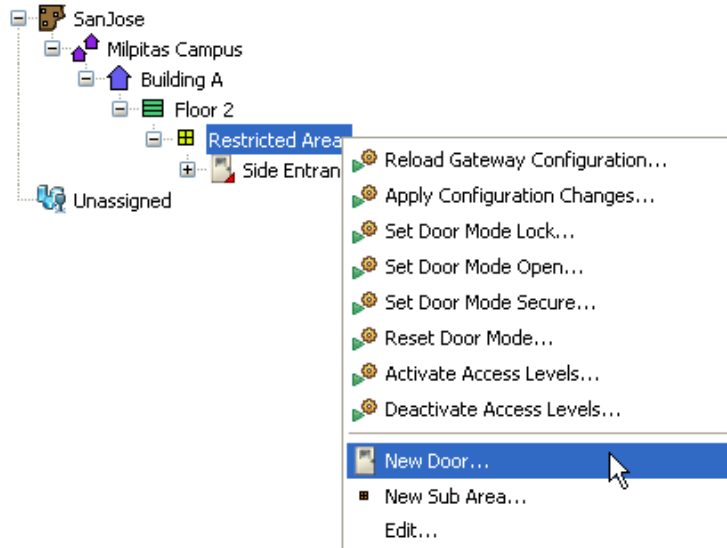

**Note** If the location does not exist, refer to [Creating the Location Map, page 5-8](#) for more information.



**Tip** You can also create a door in the Hardware Tree module. Right-click on the physical driver and select **New Door**.

**Step 3** Enter the **General** settings:

- **Door name:** enter a descriptive name for the door configuration.
- **Door Template:** select the door template that contains the correct set of door devices. See [Configuring Door Templates, page 8-2](#) for more information.
- **Gateway:** select the Gateway used for the door configuration. The devices in the door template are assigned to the gateway interfaces.

**Step 4** Select a location for the door.

- Select the **Location** submenu.
- Click **Choose** to select the location from a hierarchical map.

**Note** If you create a new door in a specific location in the Door/Location-based Hardware module, the door location takes the location of the hierarchy as a default location.

**Note** If you create a new door using the location assigned gateway in the Hardware Tree module the door location takes the location of the gateway as a default location.

- Click **Clear** to remove the setting. The door will appear in the Unassigned category.

- Step 5** Associate each device with a specific interface on a controller. If the gateway includes expansion modules, you can also choose an interface from a Reader, Input, or Output module.
- Select the **Associate Devices** submenu.

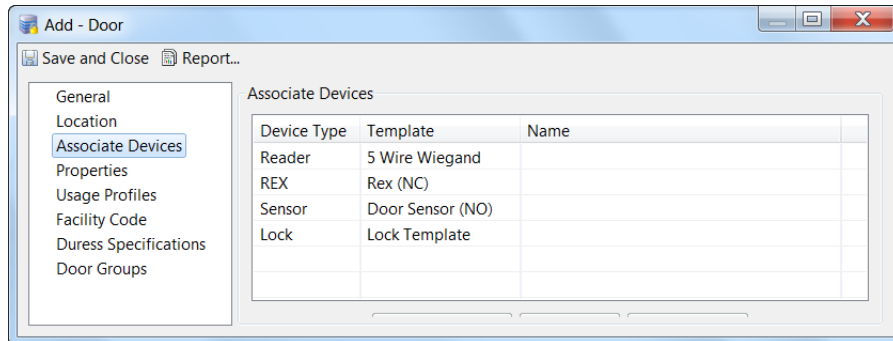

- Highlight a device (such as a reader) and click the **Associate Device** button.
- In the **Select Device** window, click the **New** button.

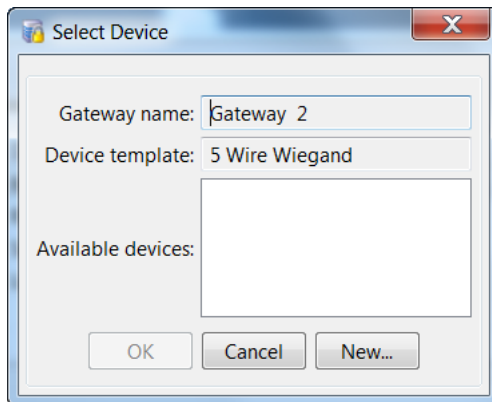

- In the **New Device** window, select a module and module interface for the device.

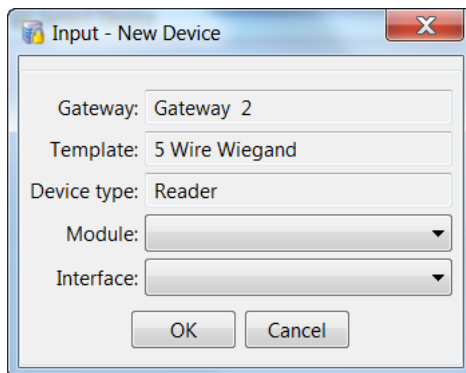

**Note** If expansion modules such as the reader, input, or output module are configured on the gateway, a selection for each relevant module is also available.

- Click **OK**.

**Step 6** Accept or modify the device settings.

The configuration for the device is pre-defined by the door template. You can accept the default settings, or modify the configuration as necessary. Changes apply only to the current device and do not affect the template.

- a. Select the **Properties** submenu.
- b. (Optional) To change the default settings for a field, deselect the Default check box. Click **Save and Close** to save the configuration.

Field	Value	Default
Relock time interval (sec):	3	<input checked="" type="checkbox"/>
Door held open time (sec):	10	<input checked="" type="checkbox"/>
Door lock on close:	<input checked="" type="radio"/> Yes <input type="radio"/> No	<input checked="" type="checkbox"/>
Deadbolt engage delay (sec):		<input checked="" type="checkbox"/>
Scheduled door mode:	(dropdown)	<input checked="" type="checkbox"/>
Door enable schedule:	None	<input checked="" type="checkbox"/>
First unlock:	<input type="radio"/> Yes <input checked="" type="radio"/> No	<input checked="" type="checkbox"/>
Default mode:	Lock	<input checked="" type="checkbox"/>
If badge not in gateway:	(dropdown)	<input checked="" type="checkbox"/>
Access decision on timeout:	(dropdown)	<input checked="" type="checkbox"/>
If server unreachable:	(dropdown)	<input checked="" type="checkbox"/>
Server access timeout (sec):		<input checked="" type="checkbox"/>
If server unreachable (APB):	(dropdown)	<input checked="" type="checkbox"/>
ADA time interval multiplier:	5	<input checked="" type="checkbox"/>
Door swing activation delay(sec):		<input checked="" type="checkbox"/>
Door swing usage:	(dropdown)	<input checked="" type="checkbox"/>
Generic reader:	(dropdown)	<input checked="" type="checkbox"/>
Multifactor authentication timer(sec):	10	<input checked="" type="checkbox"/>
Toggle door mode:	<input type="radio"/> Yes <input checked="" type="radio"/> No	<input checked="" type="checkbox"/>
Door Sensor Timer (sec):		<input checked="" type="checkbox"/>

See [Device Configuration Properties, page 8-30](#) for more information.

**Step 7** Select the interface for the device in the **Select Device** window:

- a. Highlight the interface from the list in the **Available Device** field. This list includes the available unused ports from the gateway and any expansion modules attached to the gateway.

- b. Click **OK** to save the change and complete the device association.

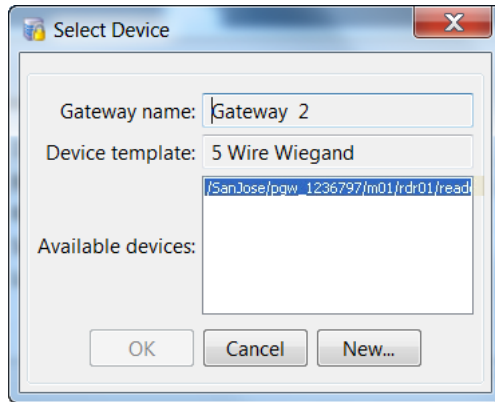

**Step 8** Repeat Steps 5 – 7 to associate each device to an interface.



**Tip** When all devices are associated with an interface, a **Name** appears for each device.

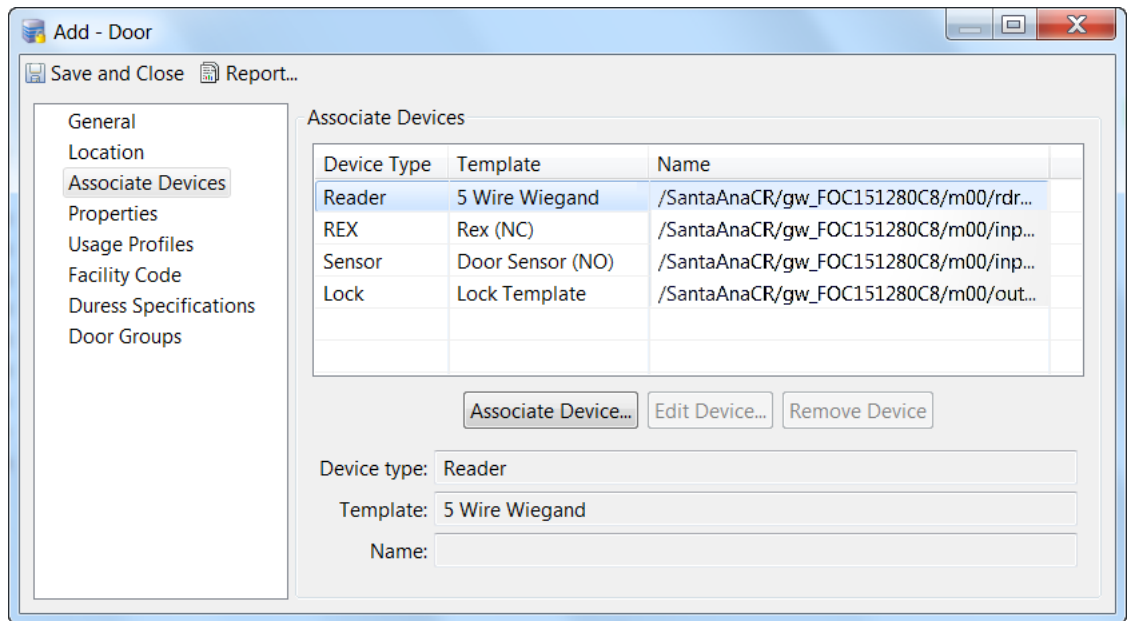

**Step 9** (Optional) Modify the Properties for the door.

- a. Click the **Properties** submenu.

- b. To change the default settings for a field, deselect the Default check box.

The screenshot shows the 'Add - Door' window with the 'Properties' tab selected. On the left, a navigation pane lists various configuration categories, with 'Properties' highlighted. The main area displays numerous configuration fields, each with a 'Default' check box on the right. A green vertical box highlights this column of check boxes, indicating that they are all currently checked.

For more information see the following:

- [Chapter 5, “Understanding Controller and Door Configurations”](#)
- [Door Configuration Properties, page 8-28](#)

**Step 10** (Optional) Modify the LED Usage Profiles for the door.

- a. Click the **Usage Profiles** submenu.
- b. To change the default settings for a field, deselect the Default check box.

The screenshot shows the 'Add - Door' window with the 'Usage Profiles' tab selected. In the left navigation pane, 'Usage Profiles' is highlighted. The main area shows several dropdown menus for 'Grant access', 'Grant access ADA', 'Deny access', 'Grant access facility code', 'Mode open', 'Mode close', and 'Mode lock'. A green box highlights the 'Default' check box, which is currently checked.

**Note** If there are two doors created from a gateway, the reader LED profile changes does not apply to the second door.

See [Configuring Reader LED Profiles, page 8-24](#) for more information.

- Step 11** (Optional) Modify the Facility Codes for the credential templates used in the door configuration:
- a. Click the **Facility Codes** submenu.

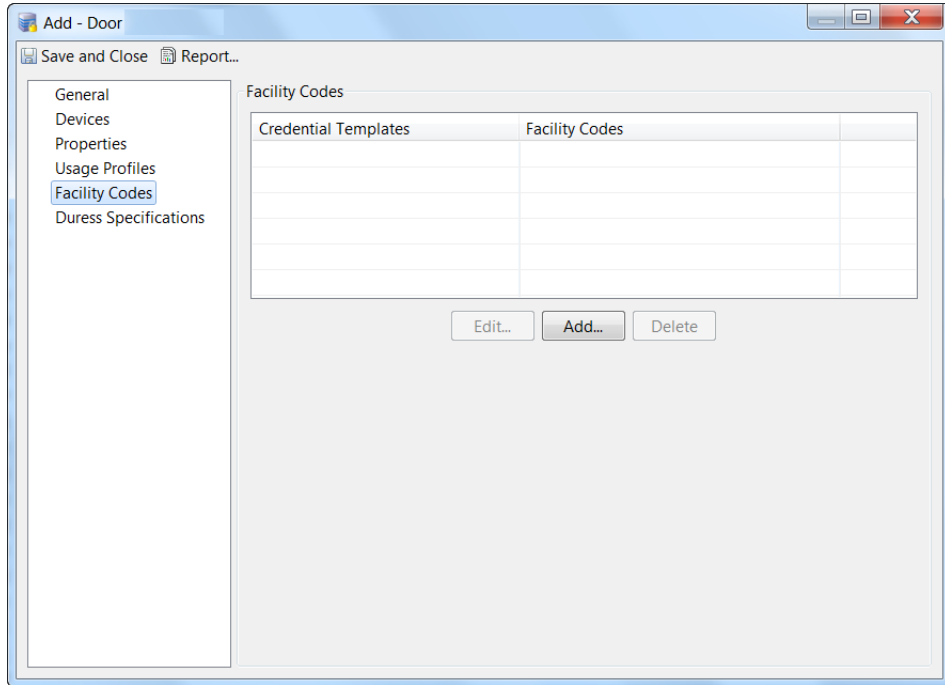

- b. Click **Add** to add a credential template to the list.
- c. Select a credential template from the drop-down menu.
- d. Enter the Facility Codes. Separate codes with a comma (,).
- e. Click **Save**.

**To edit a credential template:**

- a. Highlight the template in the Credential Template list box.
- b. Click **Edit**.
- c. Select a credential template from the drop-down menu.
- d. Enter the Facility Codes. Separate codes with a comma (,).

**To delete a credential template:**

- a. Highlight the template in the Credential Template list box.
- b. Click **Delete**.

**Note** By default a door can have 26BitWeigandCT credential with 456,123 facility codes.

See [Configuring Credential Templates, page 8-15](#) for more information.

- Step 12** (Optional) Modify the Duress Specifications for the door.
- Click the **Duress Specification** submenu.
  - Uncheck the **Default** check box to activate the configuration fields.

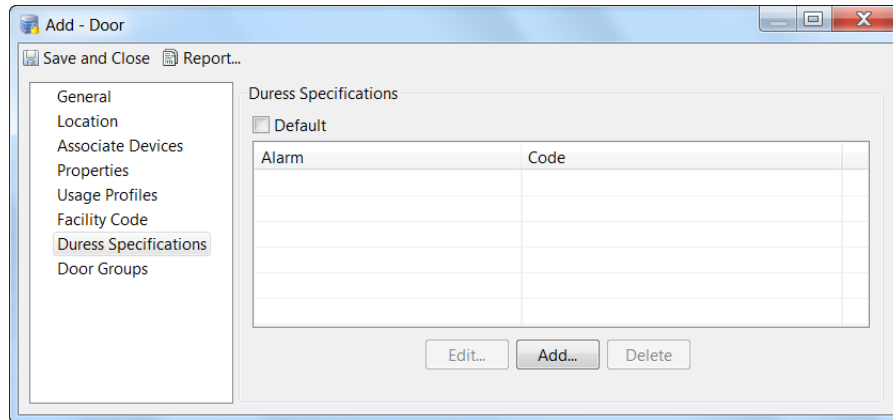

- Click **Add** to add an alarm to the list.
- Select an Alarm from the drop-down menu.
- Enter the Code.
- Click **Save**.

**To Edit an alarm:**

- Highlight the alarm in the list box.
- Click **Edit**.
- Select an alarm from the drop-down menu.
- Enter the Code.

**To Delete an alarm:**

- Highlight the alarm in the list box.
- Click **Delete**.

- Step 13** Click **Save and Close** to save the changes and return to the main window.

The door configuration is displayed as a child of the selected location.

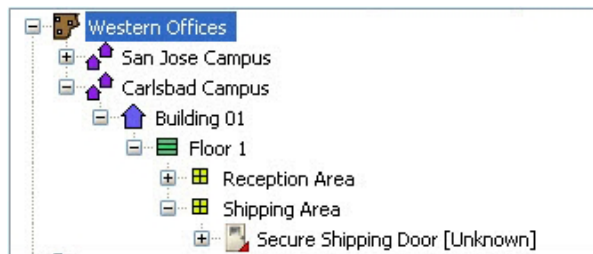

**Note** The door is also listed under the Physical Driver in the Hardware Tree module.



**Step 14** Apply the door configuration changes.

In the Door/Location-based Hardware module, right-click a location and select **Apply Configuration Changes**. Only gateways in the Up state are updated.

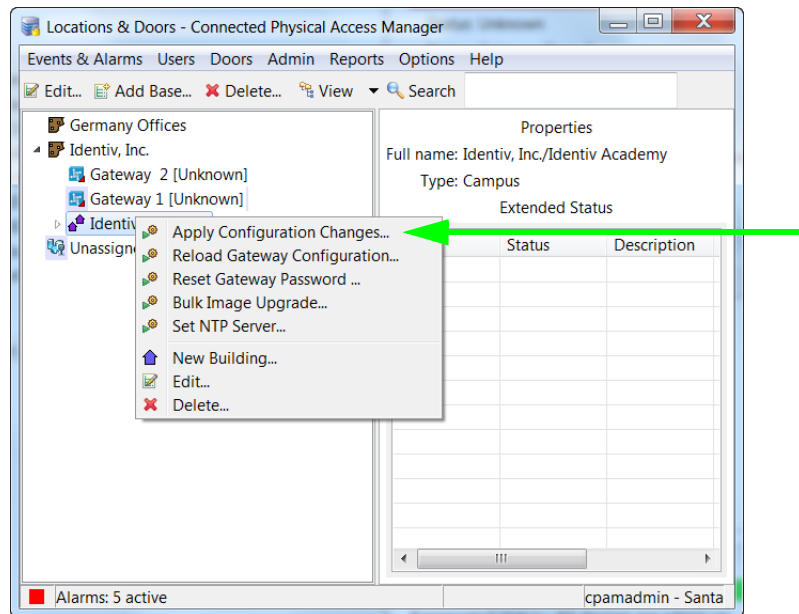

For more information, see [Applying Configuration Changes, page 7-14](#).



**Tip**

The names of all hardware elements are editable, including drivers, controllers, expansion modules, and door devices.

#### Related Documentation

- [Provisioned \(Pre-Populated\) vs. Discovered Controller Configurations, page 5-2](#)
- [Creating Custom Gateway Configurations without Templates, page 6-2](#)
- [Configuring Gateways Using Existing Templates, page 6-7](#)

## Modifying Door Configurations

This section includes instructions to modify an existing door or device configuration using the following methods:

- [Modifying Doors and Devices in the Hardware Tree View, page 7-12](#)
- [Modifying Devices in the Door/Location-based Hardware Module, page 7-13](#)

## Modifying Doors and Devices in the Hardware Tree View

To manually revise the properties for a controller, expansion module, or other device, do the following:

- Step 1** Select **Hardware Tree** from the **Doors** menu.
- Step 2** Expand the hardware tree, right-click on the device name, and select **Edit**, as shown in [Figure 7-1](#). You can also double-click the device name to open the edit window.
- Step 3** Click **Properties** in the device window, and edit the settings as necessary.  
For more about the property sheets that are available for this operation, refer to [Door Property Sheets](#), [page 7-31](#).
- Step 4** To override the template settings, deselect the **Default** check box to activate the field. For field descriptions, see [Door Configuration Properties](#), [page 8-28](#) and [Device Configuration Properties](#), [page 8-30](#).
- Step 5** Download the configuration changes to the controller. Changes do not take effect until downloaded.

**Figure 7-1** Edit Menu for a Device in the Hardware Tree View

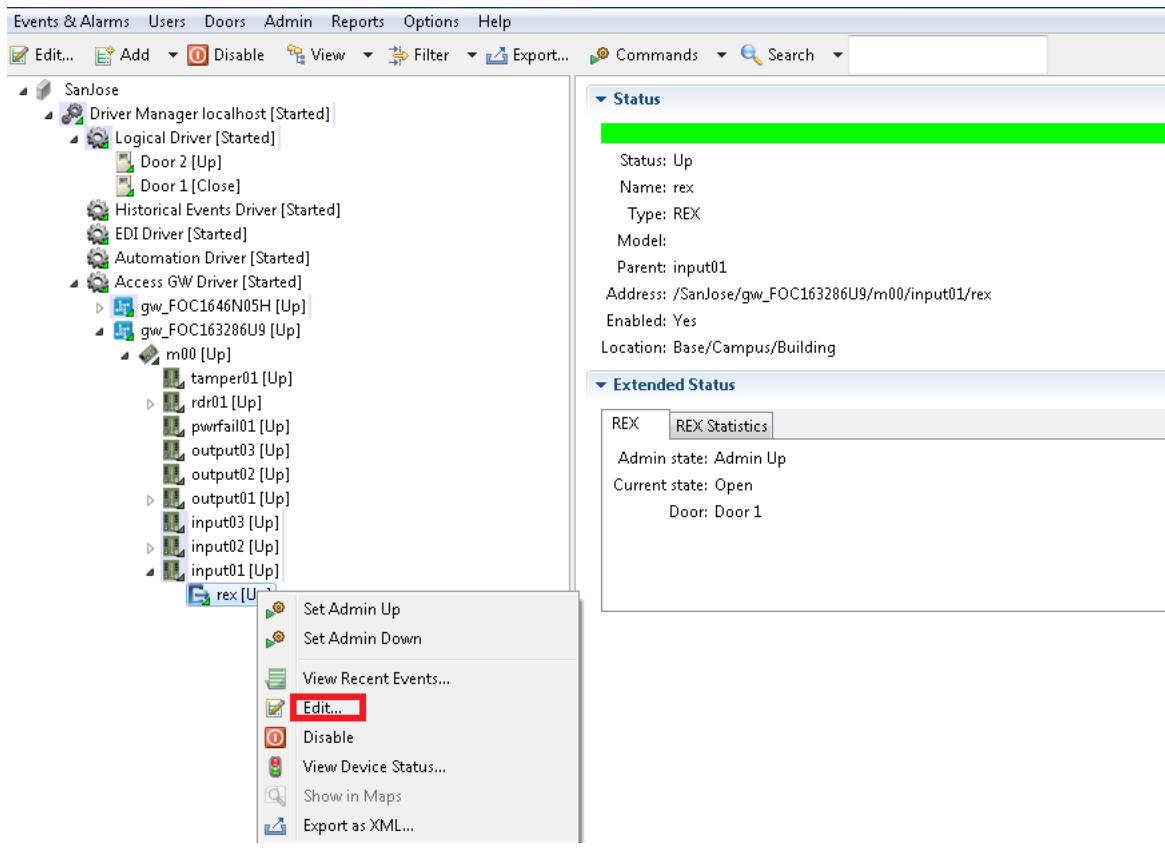

## Modifying Devices in the Door/Location-based Hardware Module

In the Door/Location-based Hardware module, you can edit all attributes of a door configuration, including device properties and the location map.

For instructions about how to modify the location map, see [Creating the Location Map, page 5-8](#).

- Step 1** In the Door/Location-based Hardware module, expand the location tree to display the door configuration or a specific device.
- Step 2** Right-click on the door or device name and select **Edit**, as shown in [Figure 7-2](#).



**Tip** You can also double-click a door or device to open the edit window.

For more information on the pages in the Door Edit window, refer to [Door Property Sheets, page 7-31](#).

**Figure 7-2** Edit Menu for a Device in the Hardware Tree Location View

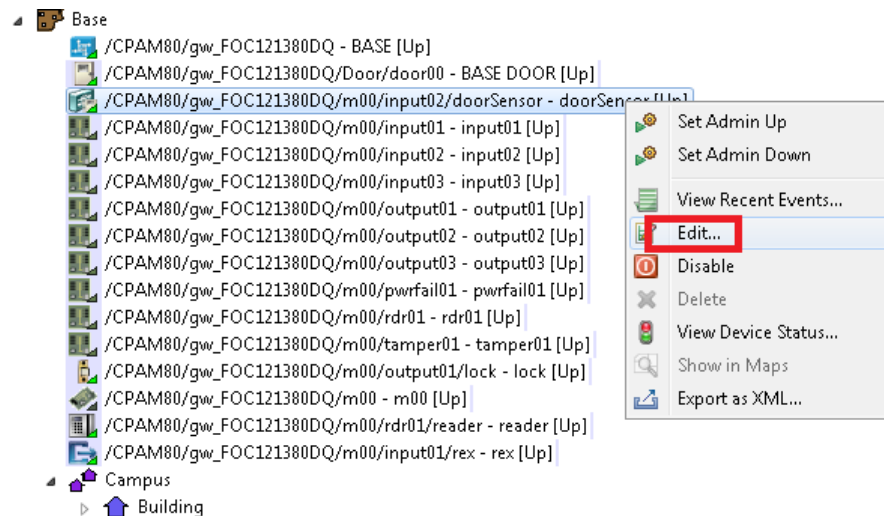

- Step 3** Select a submenu and edit the settings as necessary. To override the template properties, deselect the Default check box to activate the field.
- For more information on the pages in the Door Edit window, refer to [Door Property Sheets, page 7-31](#).
- Step 4** Download the configuration changes. For more about this process, see [Applying Configuration Changes to Controllers, page 7-14](#).



**Tip** The names of all hardware elements are editable, including drivers, controllers, expansion modules, and door devices.

## Applying Configuration Changes

Changes made to a door or device configuration in ICPAM are inactive until applied to the controller. You can apply the configuration changes to a specific controller, to all controllers, or to all controllers in a location. Applying a configuration downloads the revised configuration file to the controller.

Controllers must be in the Up state, signified by a green triangle in the icon. A dark green triangle signifies that the controller has configuration changes that have not been applied (downloaded).

This section includes the following information.

- [Applying Configuration Changes to Controllers](#), page 7-14
- [Configuration Management in Provisioned vs. Discovered Configurations](#), page 7-16

## Applying Configuration Changes to Controllers

You can download the configuration to controllers using either the **Hardware Tree** or **Door/Location-based Hardware** modules.

### Applying Configuration Changes in the Hardware Tree Module

Select **Apply Configuration Changes** on the Access GW Driver or on a specific controller.

- To download configuration changes for all controllers in the Up state, right-click on the **Access GW Driver** and select **Apply Configuration Changes**.

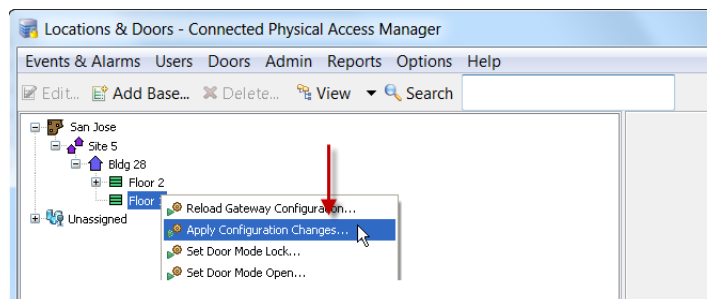

OR

- To download configuration changes only to a specific controller, right-click on that controller and select **Apply Configuration Changes**.

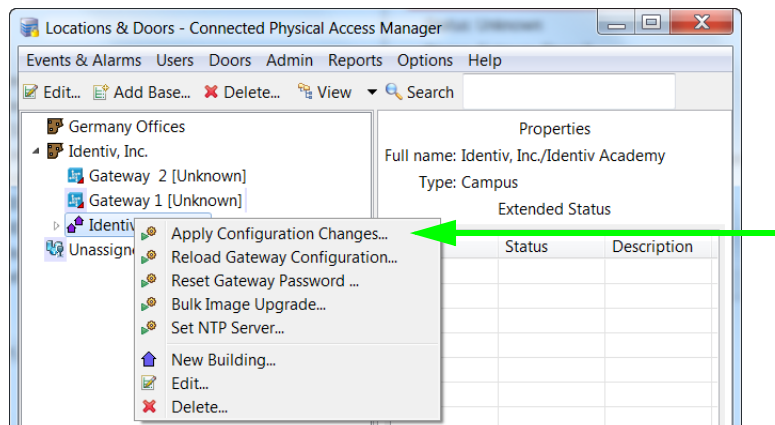

**Note** Controllers must be in the Up state, signified by a green triangle in the icon. A dark green triangle means there are configuration changes that have not been applied. See [Understanding Device Status Colors](#), page 5-15.

## Applying Configuration Changes in the Door/Location-based Hardware Module

Select **Apply Configuration Changes** on the affected controller or on a location.

### Specific Controller:

- Select **Gateway Controllers** from the **View** menu to display the gateways.
- Right-click a gateway icon and select **Apply Configuration Changes** to download the configuration only to that device.

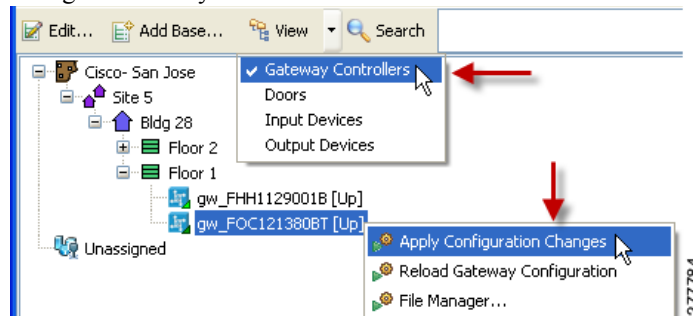

or

### Multiple Controllers:

- Right-click a location icon.
- Select **Apply Configuration Changes**.

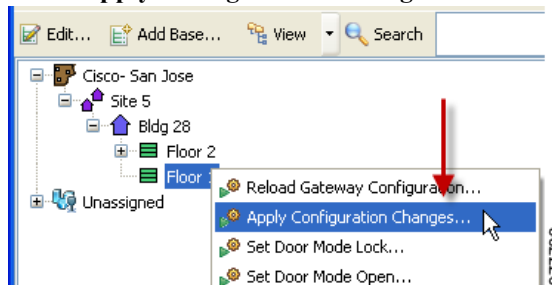

**Note** Controllers must be in the Up state, signified by a green triangle in the icon. A dark green triangle means there are configuration changes that have not been applied. See [Understanding Device Status Colors](#), page 5-15.

## Configuration Management in Provisioned vs. Discovered Configurations

- In a **Provisioned** configuration, the configuration is entered before the controller is brought online and the configuration is automatically downloaded when the controller is added to the network. Any subsequent configuration changes must be downloaded using one of the methods described in this section.
- In a **Discovered** configuration, the controller is added to the network before a configuration is created. ICPAM automatically creates a basic configuration containing the serial numbers of the controller and any expansion modules. Any subsequent configuration changes must be downloaded using one of the methods described in this section.
- If a controller power-cycles or is disconnected and reconnected to the network, the last configuration applied to the module will automatically be downloaded when the module comes online.



Note

See [Provisioned \(Pre-Populated\) vs. Discovered Controller Configurations, page 5-2](#) for more information.

## Disabling or Deleting a Door

Disabling a device or door configuration deactivates the item, but does not remove it from the ICPAM configuration. This allows you to remove the device or door from the active configuration without deleting it entirely. The device or door can be re-enabled, if necessary, and the configuration, events, logs and alarms associated with the device or door are retained.



Note

Interface and drivers (such as the Access GW Driver and physical driver) cannot be disabled.

When you delete a device or door, all configurations and other information, including events and logs, are also permanently deleted and cannot be recovered. Only deactivated devices or doors can be deleted. Identiv does not recommend deleting devices since clearing a large number of events can be time and processor intensive.

This section includes the following information:

- [Disabling a Device or Door, page 7-16](#)
- [Deleting Devices and Doors, page 7-18](#)
- [Enabling a Device or Door, page 7-20](#)

## Disabling a Device or Door

To disable a device or door, right-click the item and select **Disable** from the pop-up menu.



Note

Changes are not applied until you download the revised configuration to the controllers.

- Step 1** Select either **Hardware Tree** or **Door/Location-based Hardware** from the Doors menu.
- Step 2** Right-click a controller, door configuration, or other device, and select **Disable** ([Figure 7-3](#)).

**Figure 7-3** *Disabling a Device Using the Hardware Tree Module*

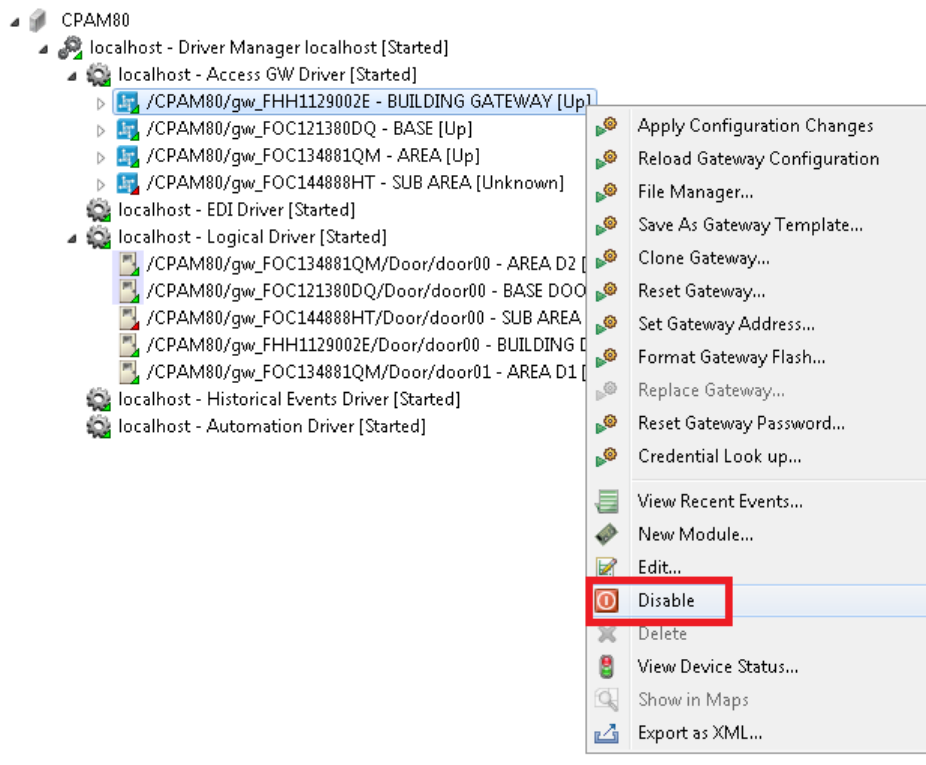

- **Disabling a device:** removes the controller association and may disable the door configuration. A confirmation message appears describing the impact of disabling the device.
- **Disabling a Gateway:** disables all associated devices and door configurations. A confirmation message appears describing the impact of the action.
- **Disabling a door configuration:** a confirmation window allows you to select the associated devices to be disabled, as shown in [Figure 7-4](#). Select the devices to be disabled, or check the box for **Select All**, and then click **Yes**.

**Figure 7-4** *Confirmation Warning When Disabling a Door Configuration*

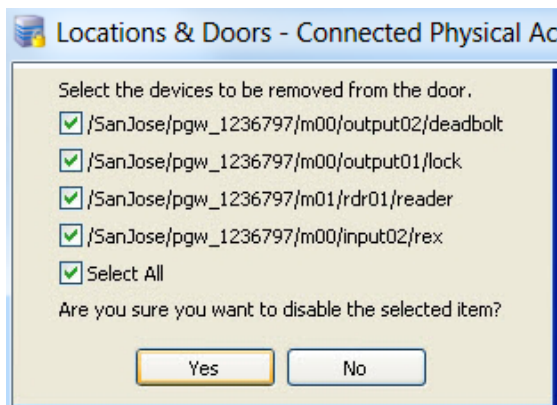

- Step 3** Download the configuration changes to the controller. Changes do not take effect until downloaded.
- Step 4** (Optional) To delete a device, controller or door configuration, see [Deleting Devices and Doors](#), page 7-18.

**Tip**

---

To view disabled devices, select **All Devices** from the **Filter** menu.

---

## Deleting Devices and Doors

When a device is deleted, the device is permanently removed from the ICPAM configuration. All events associated with the device are also permanently deleted. Neither the device or the events can be restored. This is different than disabling a device. When a device is disabled, it remains in the configuration and can be re-enabled at a later time.

**Note**

---

Identiv does not recommend deleting devices because clearing a large number of events can be time and processor intensive.

---

**Tip**

---

To delete a device or door, you must first enable the delete functions and then disable the device or door.

---

This section includes the following information.

- [Deleting a Controller, page 6-55](#)
- [Enabling the Delete Options, page 7-18](#)
- [Deleting a Device, page 7-20](#)

## Enabling the Delete Options

- 
- Step 1** Select **System Configuration** from the Admin menu.
- Step 2** Select the **Miscellaneous** submenu, as shown in [Figure 7-5](#).



Figure 7-5 Device Delete Options in the Admin Module: System Configuration

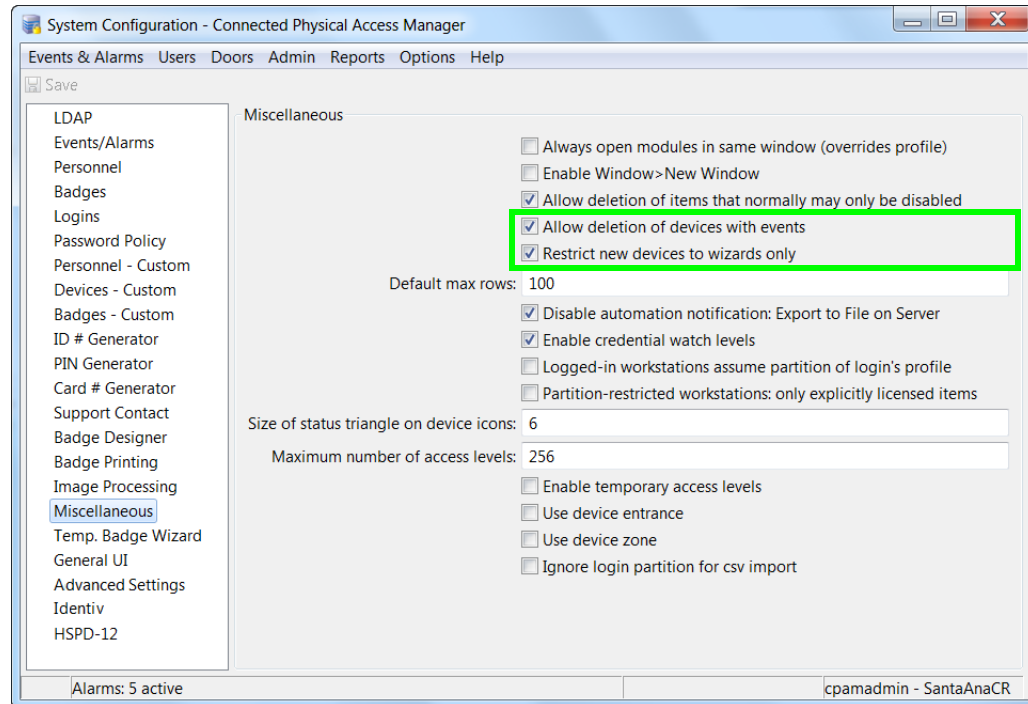

**Step 3** Select or deselect one of the following:

- **Allow deletion of items that normally may only be disabled:** Adds the **Delete** option to device and door right-click menus. Devices can be deleted only if they were previously disabled, are not referred to by another object, and if have no events or alarms. Deleting a device or door permanently removes the item from the configuration.
- **Allow deletion of devices with events:** Adds the **Delete** option to device and door right-click menus. This option deletes the device and any associated events. Items with active alarms cannot be deleted. Devices and doors can be deleted only if they were previously disabled and are not referred to by another object.



**Note**

Deleting a device may temporarily impact system performance while the associated events are also deleted. Do not delete devices and doors unless necessary.

**Step 4** Click **Save** to save the changes.

**Step 5** Log out (select **Logout** from the **Options** menu) and log back in to the ICPAM application to enable the changes. The Delete menu does not appear in ICPAM until you log out and log back in.

## Deleting a Device

To delete a device, do the following:

- 
- Step 1** Enable the Delete functions, as described in [Enabling the Delete Options, page 7-18](#).
  - Step 2** Disable the device, as described in [Disabling a Device or Door, page 7-16](#).
  - Step 3** Select **All Devices** from the **Filter** menu to display one or more disabled devices.
  - Step 4** Right-click the device and select **Delete**.
  - Step 5** Select **Yes** to confirm.
  - Step 6** Download the changes to the controller, as described in [Applying Configuration Changes to Controllers, page 7-14](#).
- 

## Enabling a Device or Door

When a device is disabled, the door is also disabled. To re-enable a door and device, re-associate all devices and then enable the door, as described in the following example.

### Disable and Enable a Device and Door: Example

The following example describes how to disable and then re-enable a device:

- 
- Step 1** Disable a device:
    - a. Right-click the device and select **Disable**. A confirmation message appears.
    - b. Click **Yes** to disable the device. The door is also disabled.

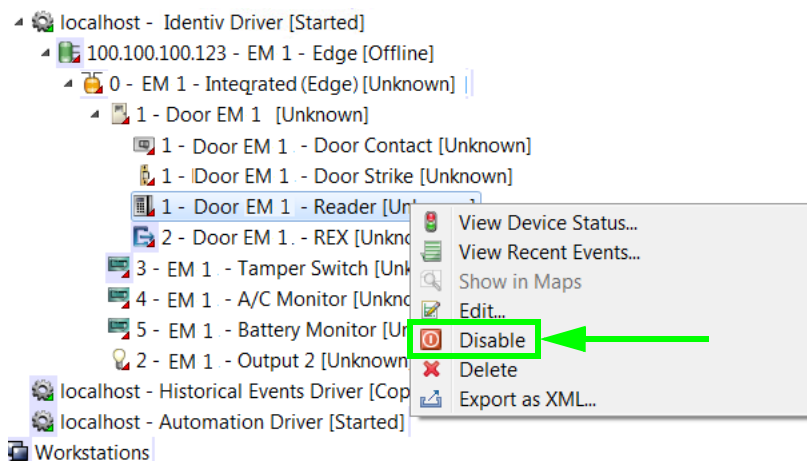

- Step 2** Accept or modify the device settings.  
Click **Save and Close** to save the configuration.

**Step 3** Re-enable the door.

**Note** To re-enable a door, you must reassociate the device with the door.

- a. Select **All Devices** from the Filter menu to display one or more disabled devices.
- b. Right-click on the door and select **Edit** to open the edit window.
- c. Select the **Associate Devices** submenu, as shown in the example to the right.
- d. Highlight a device (such as reader) and click **Associate Device**.

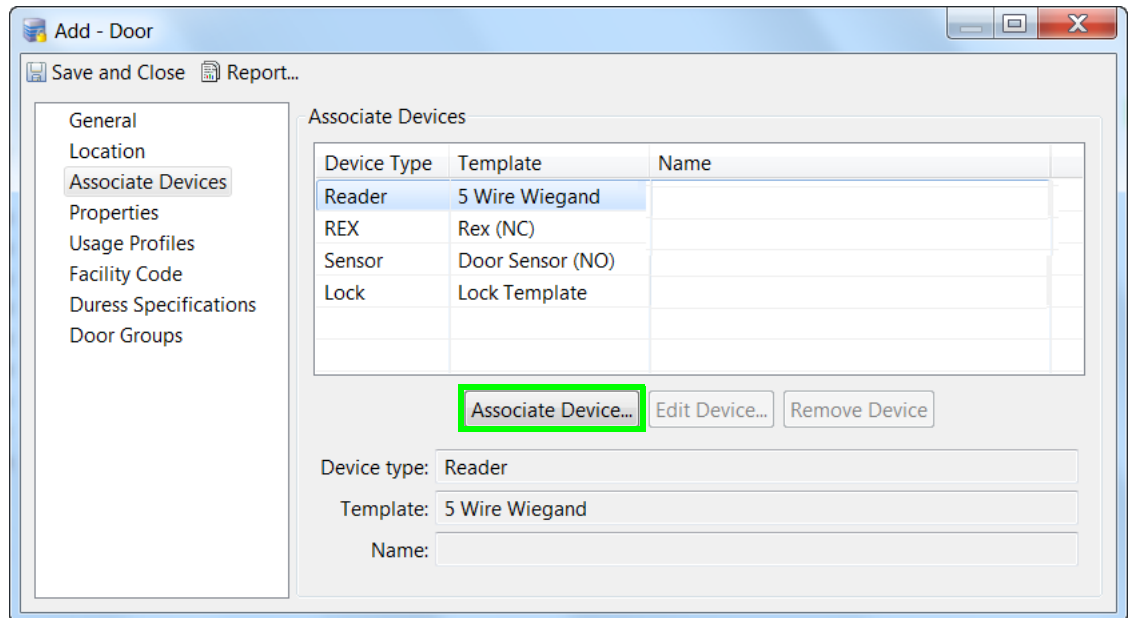

- e. In the resulting **Select Device** window, click the **New** button.

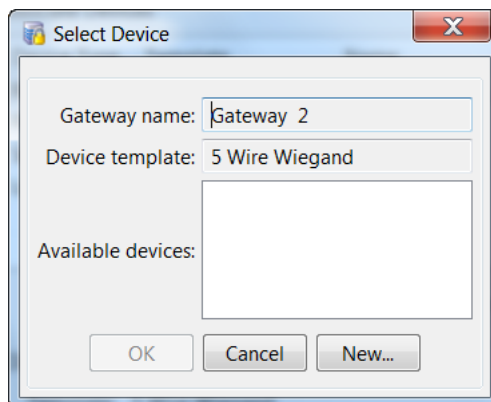

- f. In the **New Device** window, select a module and module interface for the device.

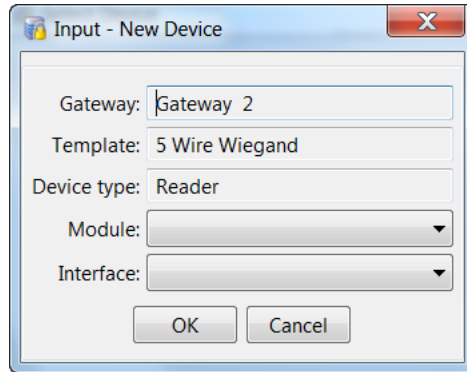

- g. Click **OK**.

**Step 4** Select the interface for the device in the **Select Device** window:

- a. Highlight the interface from the list in the **Available Device** field. This list includes the available unused ports from the controller and any expansion modules attached to the controller.
- b. Click **OK** to save the change and complete the device association.

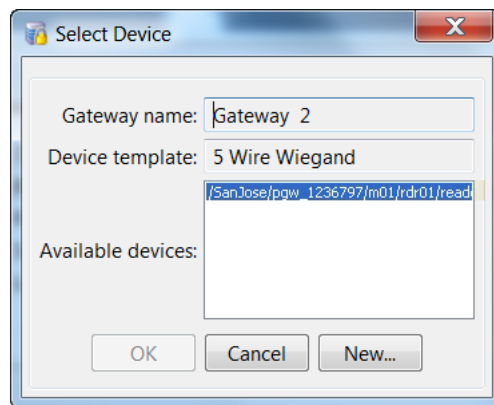

**Step 5** Associate additional devices, or save the changes:

- a. Verify that an entry appears in the **Name** column for each device.
- b. Associate any additional devices that do not appear with a name.

- c. Click **Save and Close** to save the configuration and re-enable the device.

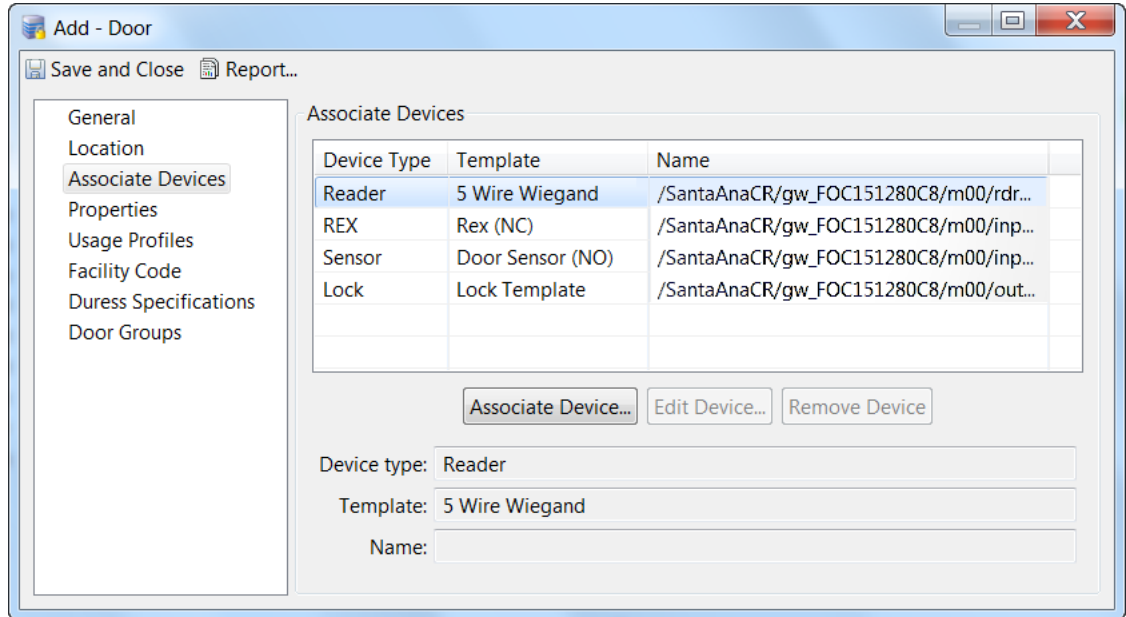

**Step 6** Re-enable the door.



**Note** The device should appear again under the door.

**Step 7** Right-click the door name and select **Enable**.

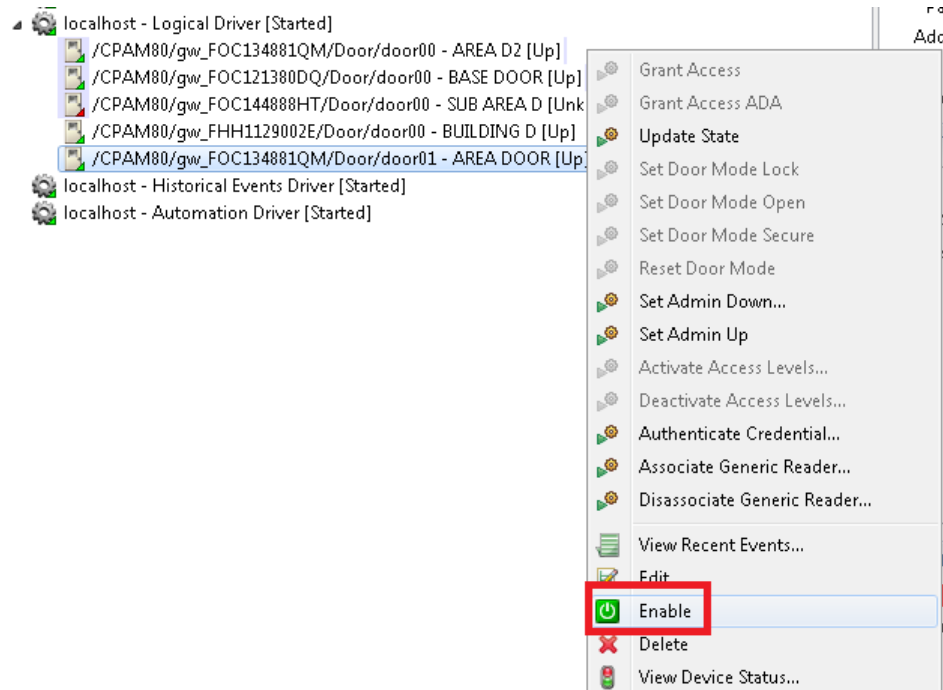

- Step 8** To apply the door configuration changes, right-click a location or controller and select **Apply Configuration Changes**. Only controllers in the Up state are updated.

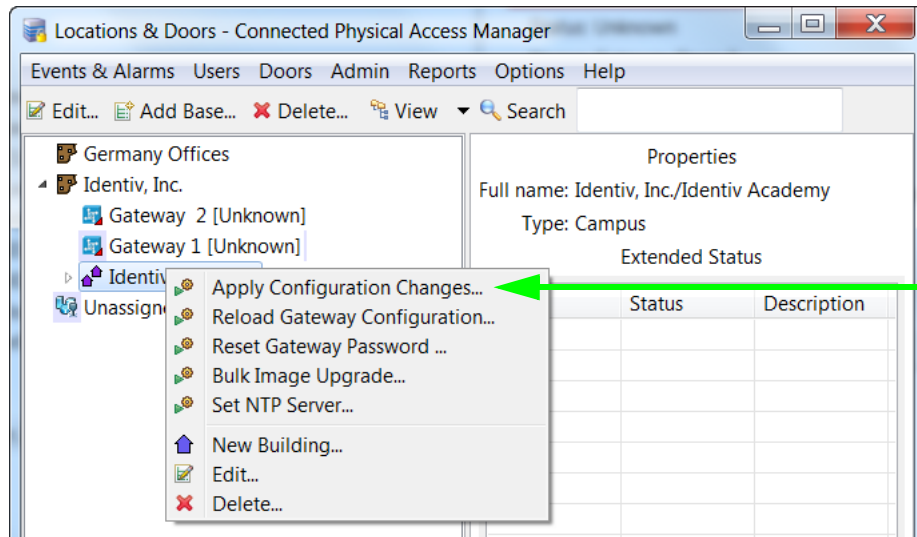

For more information, see [Applying Configuration Changes to Controllers, page 7-14](#).

## Configuring Device Groups

Use device groups to create sets of devices for use in other configuration menus such as Event Policies ([Modifying Default Event Policies, page 12-37](#)), Global I/O, Quick Launch, Map, and Access Policies ([Configuring Access Policies, page 11-2](#)).

For example, a device group for all lobby doors can be created, and then specified in an access policy. Users assigned to that access policy will only have access to doors in that device group.

### Device Groups in ICPAM 2.1

If the profile enhancement feature is set in the system configuration settings (see [Logins page of the System Configuration window, page 17-11](#)), the following changes are impacted in this module:

- The device groups present in the users hierarchical location and sub locations alone can be added. Only those device groups of locations to which the user profile is associated with is displayed for selection. For example: If a user assigned location is 'BVVC' only those device groups under BVVC is displayed. See ([Figure 7-6](#)).

Figure 7-6 Device Groups based on hierarchical Location

The screenshot shows a window titled "Add - Device Group". At the top, there are buttons for "Save and Close" and "Report...". Below these are several input fields: "Name:" with the text "New Group", "Type:" with a dropdown arrow, "Comments:" with a text area, and "Location:" with a dropdown arrow. The "Location:" dropdown is highlighted with a green border. Below the "Location:" field are two buttons: "Choose..." and "Clear". Underneath is a section titled "Group members" which includes a "Filter" icon, a "Uncheck All" button, and a "Search" input field. Below this is a list box containing one item, "SantaAnaCR", with an unchecked checkbox to its left.

- While creating device groups, a location-restricted user can view devices up to the root of their respective location hierarchy. However only those devices that are within their assigned location are available for selection (to form a device group).
- The location-restricted user can reuse device groups present up to their root level provided there is at least one device in those groups that belong to their assigned location, this behavior is specific to global I/O and graphical editor.

**Note**

These points are applicable only when the profile enhancement feature is set on the **Logins** page of the **System Configuration** window (starting with the ICPAM 2.1 release); otherwise, the ICPAM appliance retains its behavior as in the previous version (CPAM 1.5.1).

To configure device groups, do the following:

**Step 1** Select **Device Groups** from the **Doors** menu.

The Device Groups - Physical Access Manager window opens, as shown in [Figure 7-7](#).

Figure 7-7 Device Groups Window

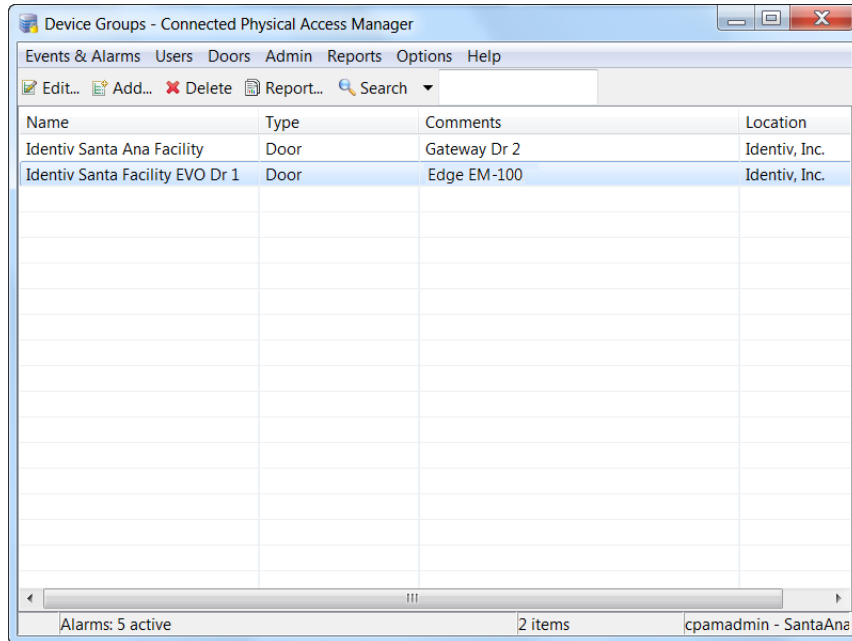
**Step 2** Add or edit a device group.

- To add a new device group, click **Add**.
- To modify an existing record, select the record and click **Edit**, or double-click the entry.



**Note** To remove a device group, you must first remove any configurations for that group in the Access Policy or Event Policy modules. Once the associations are removed, select the entry and click **Delete**. If you attempt to remove a device group that is still in use, a pop-up message appears with a summary of the access and event policies that are associated with the group.



**Step 3** In the resulting window (Figure 7-8), enter a **Name** for the device group.

*Figure 7-8 Add Device Group Window*

**Step 4** From the **Type** drop-down list select any one of the following devices types:

- Door
- Controller
- Module
- Reader

When selected, the Group Members field displays the devices for that device type. Site is auto-populated.

**Step 5** Select the location.

**Step 6** Select the devices to include in the group.



**Tip**

- Devices can belong to multiple groups.
- Check the site name to select all the devices for that site.
- Click **Uncheck All** to clear the selections.

**Step 7** Click **Save and Close** to save the changes. The new door group appears in the main window (Figure 7-7).

# Adding an Expansion Module in an Existing Setup

An expansion module can be added in one of the following modes:

- Auto-discover
- Provision

## Auto-Discover

To add an expansion module, connect the module with the controller using a CAN bus. The gateway automatically recognizes the new module, and enables the device in the Hardware Tree module under the controller. It is necessary to provide external power to power up the expansion module (12 V DC or 24 V DC).

## Provision Mode

To add an expansion module in the provision mode, follow the below steps:

- 
- Step 1** Right-click on the controller and select **New Module** from the pop-up menu.
  - Step 2** Select one of the modules (Input/Output/Reader) from the drop-down list.
  - Step 3** If you select the reader module, select the reader connection mode (either one or two readers).
  - Step 4** Enter a valid serial number and then click Finish. This physically connects the module with gateway using a CAN bus. It is necessary to provide an external power source to power up the expansion module.
  - Step 5** Execute the Apply Configuration Changes command to make the module active.
- 

# Replacing an Expansion Module for a Gateway

To replace an expansion module in an existing setup, follow the below steps:

- 
- Step 1** Remove the module that is to be replaced and disable it.
  - Step 2** Execute the replace module command with a valid serial number, and enable it.
  - Step 3** Execute the **Reload Gateway Configuration** command to update the correct serial number.
-

# Adding an Exit Reader to the Door of an EM-100 Controller

The ICPAM 2.1 release introduced support for Identiv's EM-100 single-door controller, which provides support for a single reader. The ICPAM 2.2 release introduced support for the optional Exit Reader Expansion Module, which enables you to add a second (exit) reader to the door of an EM-100 controller. Having an exit reader makes it possible to better track a person's location or movements, and provides more flexibility when defining and enforcing anti-passback areas. For detailed information about installing this optional module, see "Connecting an Exit Reader Expansion Module" in the *ICPAM Installation Guide*.

If you are adding a new EM-100 controller with an optional Exit Reader Expansion Module to your ICPAM system, see [Adding an EM-100 Controller with an Exit Reader Expansion Module, page 6-25](#).

If you are adding an optional Exit Reader Expansion Module to an EM-100 controller which is already part of your ICPAM system, then after installing the module, you must configure it by performing the following steps.

- Step 1** Open the Hardware Tree module by selecting **Doors > Hardware - Tree**, and if necessary select **View > Device**.
- Step 2** Expand the tree under the **Driver Manager > Identiv EM-100 Driver** so the elements of the desired EM-100 controller are visible, then right-click on the element and choose the **New Slave Door...** command. For example:

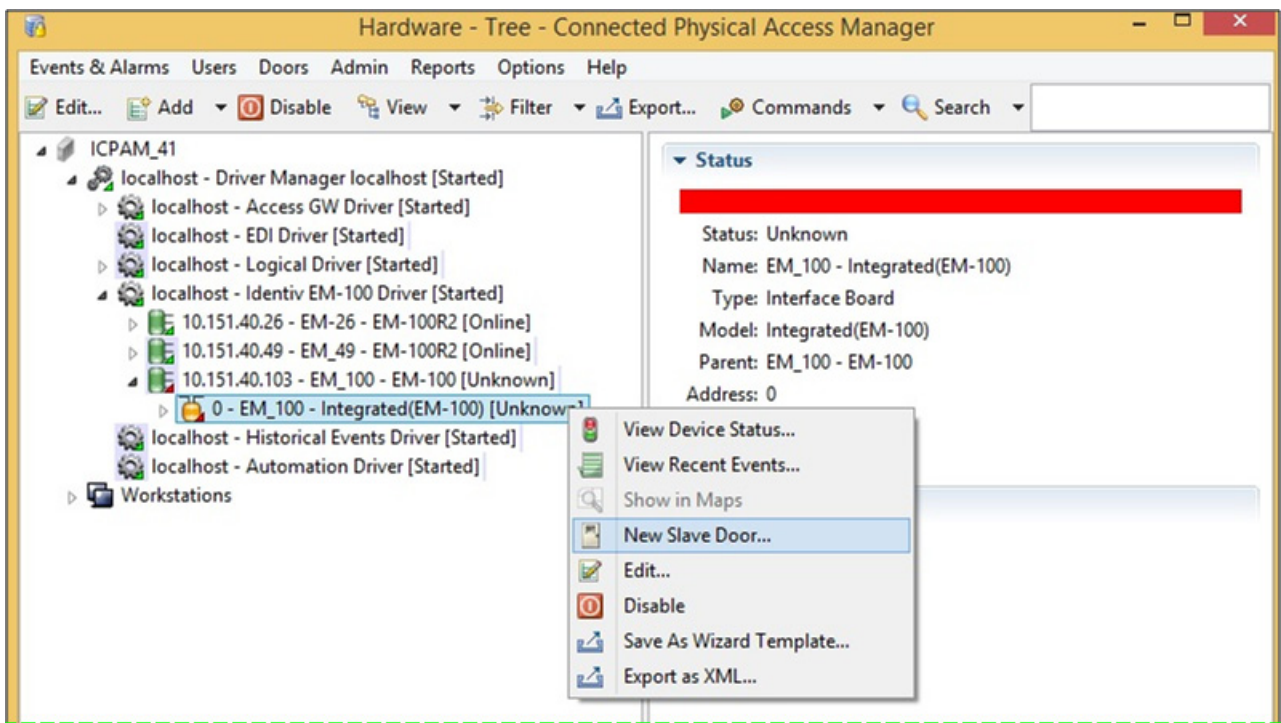

- Step 3** On the resulting **Slave Door** dialog, configure the new exit reader (for this EM-100 single-door controller):

- a. In the **Name** field, type a name for this exit reader, which must be unique within the Identiv EM-100 Driver portion of the Hardware Tree. (If your site does not follow a specific naming convention, you might want to use a descriptive name such as “Exit Engineering Lab through South door”.)
- b. From the **Access mode** drop-down list, select the access mode for this door’s exit reader. Depending on your System Configuration settings, the choices might include **Card only**, **PIN only**, **Card and PIN**, and **Card or PIN**.

Note that to use one of the PIN access modes, the card reader must be equipped with a numeric keypad, and user credentials must include a PIN code. For more information, refer to [Configuring an EM-100 Controller with the Desired Access Mode, page 6-33](#).

The **Door contact supervision** drop-down list is disabled on this page about the new exit reader; this configuration value was specified on the **Door 1** page when this controller was added to your ICPAM system (with only the standard entry reader).

The **REX supervision** drop-down list is disabled on this page about the new exit reader; this configuration value was specified on the Door 1 page when this controller was added to your ICPAM system (with only the standard entry reader).

- c. From the **Keypad type** drop-down list, select the appropriate value for this exit reader. The choices are **[no keypad]**, **4-bit burst mode**, **8-bit burst mode**, or **Mercury**.
  - d. Click **Finish** to close this wizard.
- Step 4** Check the Hardware Tree to ensure that the new exit reader appears beneath the selected EM-100 controller.
- Step 5** Restart the **Identiv EM-100 Driver**, to activate the new exit reader.

# Door Property Sheets

When you edit a door's properties, either through [Modifying Doors and Devices in the Hardware Tree View, page 7-12](#) or [Modifying Devices in the Door/Location-based Hardware Module, page 7-13](#), a window resembling [Figure 7-9 on page 7-31](#) or [Figure 7-10 on page 7-32](#) appears, depending on which controller you are using, EM-100 or Cisco Gateway.

There are seven pages in this window, each of which is detailed in this section.

**Figure 7-9** *EM-100 Edit Door Property Sheet*

The screenshot shows a software window titled "Edit - Door". At the top left, there are two buttons: "Save and Close" and "Report...". Below these is a navigation pane with a list of tabs: "General" (which is selected and highlighted), "Location", "Door", "Hardware Rules", "Audit Records", "Recent Events", and "Device Commands". The main content area displays the "General" tab's configuration. It includes the following fields and options: "Name: Door EVO 1" (text input), "Type: Door" (text input), "Model:" (dropdown menu), "Usage:" (dropdown menu), "Parent: EVO 1 - Integrated(Edge)" (text input), "Site: SantaAnaCR" (text input), "Address: 1" (text input), a checked checkbox labeled "Enabled", and "Comments:" (text area).

If the door is attached to an EM-100 controller, these property sheets will appear:

- Door Edit General Property Sheet
- Door Edit Location Property Sheet
- Door Edit Door Property Sheet
- Door Edit Hardware Rules Property Sheet
- Door Edit Audit Records Property Sheet
- Door Edit Recent Events Property Sheet
- Door Edit Device Commands Property Sheet

**Figure 7-10** Gateway Edit Door Property Sheets

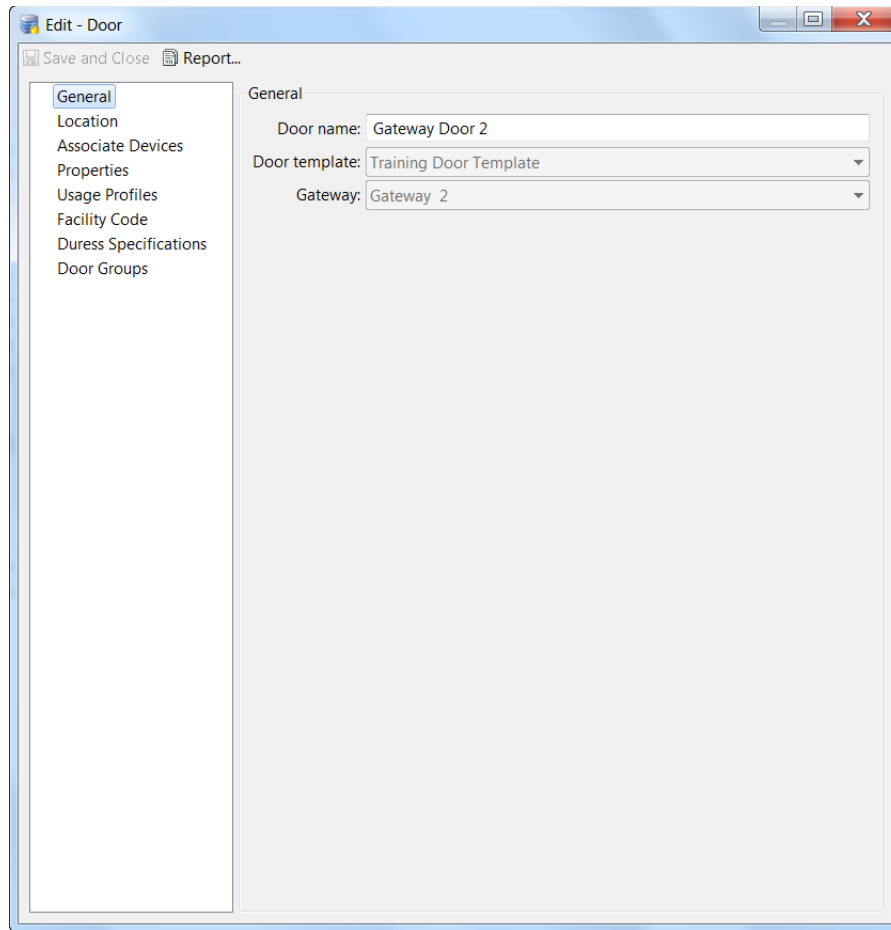

If the door is attached to a Cisco gateway, these property sheets will appear:

- Door Edit General Property Sheet
- Door Edit Location Property Sheet
- Door Edit Associate Devices Property Sheet
- Door Edit Properties Property Sheet
- Door Edit Usage Profiles Property Sheet
- Door Edit Facility Code Property Sheet
- Door Edit Duress Specifications Property Sheet
- Door Edit Door Groups Property Sheet

## General Door Property Sheet

When you select the **General** tab, a page like [Figure 7-9](#) or [Figure 7-10](#) appears.

Depending on which controller you are using, this page includes the following fields:

**Table 7-1 Gateway Door General Page**

Field	Description
Door	Enter a name for this door.
Door template	This field indicates the door template selected for this door. For more on door templates, refer to <a href="#">Configuring Door Templates, page 8-2</a> .
Gateway	This read-only field indicates the gateway to which to door is attached.

**Table 7-2**

Field	Description
Door	Enter a name for this door.
Type	This read-only field indicates the type of device described by this property sheet. This is normally a door.
Model	This read-only field indicates the model of EM-100 this door is.
Usage	From the drop-down list, select the option that describes the usage for this door. The options are: <ul style="list-style-type: none"> <li>• <b>Door</b> (default)</li> <li>• <b>Elevator</b></li> <li>• <b>Portal</b></li> <li>• <b>Turnstile</b></li> <li>• <b>Vehicle Gate</b></li> </ul>
Parent	This read-only field indicates this door's place in the system's hierarchy.
Site	This read-only field indicates the site where this door resides.
Address	This read-only field indicates the door's address.
Enabled	Check this box to indicate that this door is active and ready to communicate with the host.
Comments	If required, enter information about this door.

## Location Door Property Sheet

When you select the **Location** tab from the Gateway door property sheet, a page like this appears:

This page includes the following fields:

**Table 7-3**

Field	Description
Location	Select the location (area) where this door is located. If needed, click <b>Choose...</b> and navigate to the correct location.  Only those locations previously defined for this system appear in this option list. For more on creating location, refer to <a href="#">Creating the Location Map, page 5-8</a> .
Latitude	If needed, enter the latitude of this door.
Longitude	If needed, enter the longitude of this door.

## Associate Devices Door Property Sheet

When you select the **Associate Devices** tab from the Gateway door property sheet, a page like this appears:

This page includes a table of all devices currently associated with this door. For instructions on how to associate new devices with this door, refer to [Configuring Doors, page 7-1](#).



## Properties Door Property Sheet

When you select the **Properties** tab from the Gateway door property sheet, a page like this appears:

The fields appearing on this property sheet include:

**Table 7-4**

Field	Description
Default	Check the box to the left of each value to assume the default for that door property. Uncheck the box to specify a custom value for this door property.
Relock interval time (sec)	The number of seconds to keep the door open after an access request is granted (grant access).
Door held open time (sec)	The number of seconds before the Door Held Open alarm is generated.
Door lock on close	The default is <b>Yes</b> . The door will always lock when closed, overriding the Relock interval time (even if a second request was entered while the door was open).  Select <b>No</b> to keep the door unlocked for the duration of the Relock interval time, even if it is closed. The relock time is based on the most recent access request for the door.

Table 7-4

Field	Description
Deadbolt engage delay (sec)	The delay (in seconds) after a door closes until the deadbolt is applied.
Scheduled door mode	Select the door mode when the door scheduled is applied.  For example if the Default mode is Lock, and the scheduled door mode is Close, then the door will be locked at all times except during the hours and days defined by the schedule selected in Door enable schedule.
Door enable schedule	(optional) Select a door schedule. If you select None, then the door will remain in the Default mode at all times. If you select a schedule, the schedule will override the default mode for the times and days defined in the schedule.  See Using the Schedule Manager to add or modify the available door schedules.
First Unlock	Select <b>First Unlock</b> to activate the door schedule only on the first successful badge swipe. The door remains in default mode until a badge is used to access the door, even after the beginning time for the schedule. This is useful in situations such as snow days to ensure the door is not opened until a badge holder is physically present.
Default mode	Select the default door mode. The door remains in this mode at all times except when a schedule is defined. <ul style="list-style-type: none"> <li>• <b>Open:</b> the door is held open and the lock is in unlocked state.</li> <li>• <b>Close:</b> the door is physically closed and the lock is in unlocked state.</li> <li>• <b>Lock:</b> the door is physically closed and the lock is in Locked state.</li> <li>• <b>Secure:</b> the door is locked and the deadbolt is applied.</li> </ul>
If badge not in gateway	The action taken by the gateway if the badge is not in the gateway database.
Access decision on timeout	The action taken by the gateway if there is no response within Server access timeout.
If server unreachable (APB)	The action to be taken by gateway in case it cannot reach ICPAM. See <a href="#">Using Local (Controller) Credentials if Network Communication is Lost, page 11-24</a> .
Server access timeout (sec)	The number of seconds before an action is taken based on Access decision on timeout.
ADA timespec multiplier	The multiplier used on Relock interval time if an ADA access occurs.
Door swing activation delay (sec)	The number of seconds before the door swing is activated. This setting allows time for the door lock or other devices to activate before the mechanical door swing activates.

Table 7-4

Field	Description
Door swing usage	Select from one of these options: <ul style="list-style-type: none"> <li>• <b>Always operate</b>: the door swing activates for all access requests.</li> <li>• <b>Operate for ADA only</b>: the door swing operates only for requests from an ADA device.</li> <li>• <b>Do not operate</b>: the door swing does not operate.</li> </ul>
Generic reader	Lists the generic readers associated to the door.
Multifactor authentication timer(sec)	The number of seconds for the multifactor authentication to take place. The default time is 10 seconds.
Toggle door mode	Click the <b>Yes</b> radio button to enable toggle door mode. Click <b>No</b> to disable toggling.
Door sensor timer	Specify in seconds the time the door sensor is enabled.

## Usage Profiles Door Property Sheet

For Gateway doors, click the **Usage Profiles** tab to display the usage profiles door property sheet.

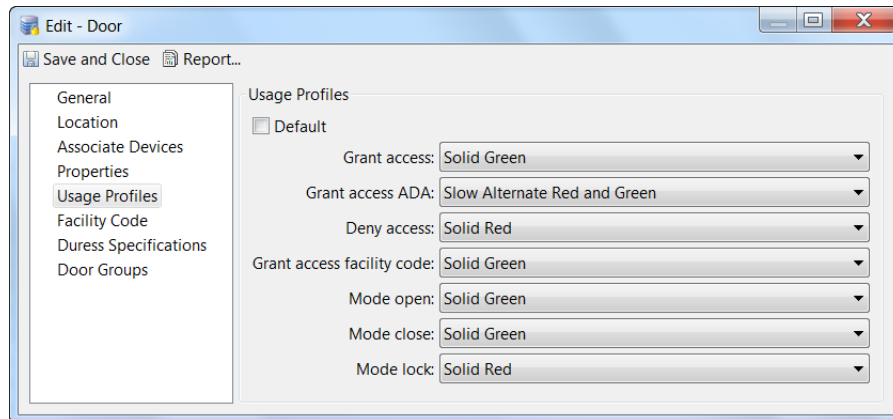

The fields on this property sheet include:

Table 7-5

Field	Description
Default	Check the box to the left of each value to assume the default for that door property. Uncheck the box to specify a custom value for this door property.
Grant access	Select a color and pattern for the grant access state applicable to this door.
Grant access ADA	Select a color and pattern for the grant access ADA state applicable to this door.
Deny access	Select a color and pattern for the deny access state applicable to this door.

Table 7-5

Field	Description
Grant access facility code	Select a color and pattern for the grant access facility code applicable to this door.
Mode open	Select a color and pattern for the mode open state applicable to this door.
Mode close	Select a color and pattern for the mode closed state applicable to this door.
Mode lock	Select a color and pattern for the mode lock state applicable to this door.

## Facility Code Door Property Sheet

When you select the **Facility Code** tab on a Cisco Gateway door property sheet, a page like this appears:

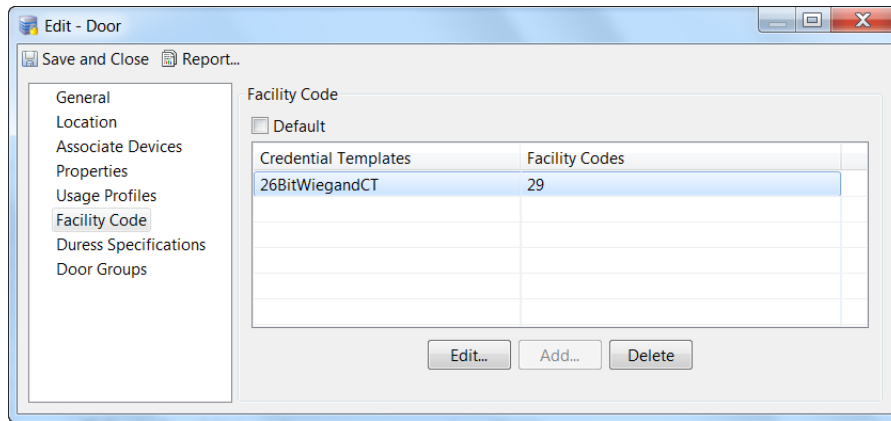

Field	Description
Default	Check this box to indicate that this door always uses the default facility code. By default a door can have 26BitWeigandCT credential with 456,123 facility codes.
Table	This table indicates the facility codes and their associated credential templates already assigned to this door.
Edit...	Click to highlight an existing entry in the table then click this button to edit an existing entry.
Add...	When active, click this button to create a new facility code.
Delete	Select an entry from the table, then click this button to delete the entry from the table.

## Duress Specifications Door Property Sheet

If you select the **Duress Specification** tab from the Gateway door property sheet, a page like this appears:

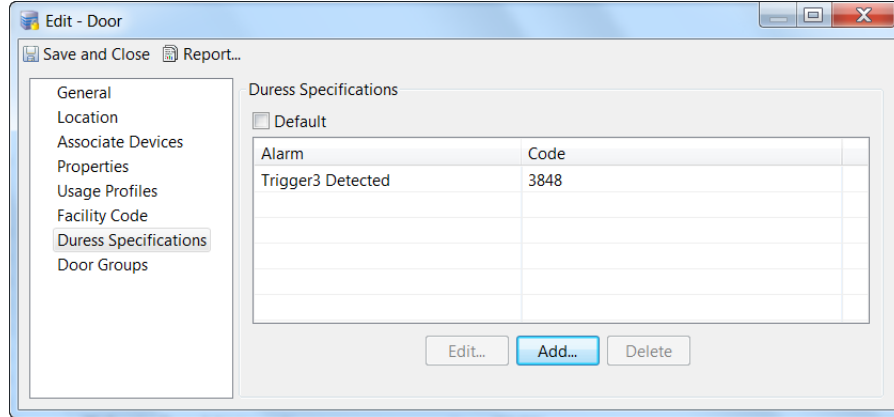

Field	Description
Default	Check this box to indicate that the default duress code is the only one acceptable.
Window	Displays a list of the currently accepted and defined duress specifications.
Edit...	Click to highlight a listed duress specification then click this button. The edit duress specification dialog box appears.
Add...	Click to display a duress specification dialog box and enter a duress code.
Delete	Click to highlight a listed duress specification then click this button to delete the specification.

## Door Groups Door Property Sheet

When you select the **Door Groups** tab from the Gateway door property sheet, a page like this appears:

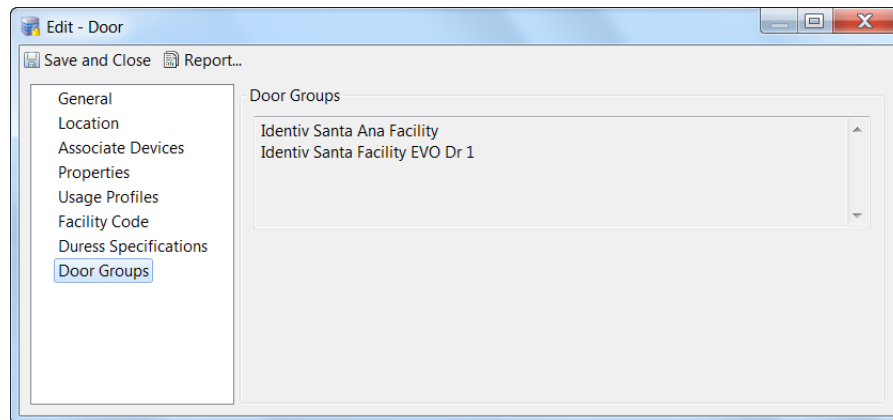

This property sheet lists the door groups in which this door is currently enrolled.

## Door Door Property Sheet

When you select the **Door** tab on an EM-100 door property sheet, a page like this appears:

The fields on this page include:

**Table 7-6**

Field	Description
Access mode	Select the access mode for this door's entry reader, which is the combination of authentication factors required to gain access to a particular secured area. Depending on your System Configuration settings, the choices might include: <ul style="list-style-type: none"> <li>• <b>Card only</b></li> <li>• <b>PIN only</b></li> <li>• <b>Card and PIN</b></li> <li>• <b>Card or PIN.</b></li> </ul> Note that to use one of the PIN access modes, the card reader must be equipped with a numeric keypad, and user credentials must include a PIN code. For more information, refer to <a href="#">Configuring an EM-100 Controller with the Desired Access Mode</a> , page 6-33.
Slave reader for door number 1	Check this box to indicate that this reader is slaved to another reader, as with readers positioned inside and outside the same door.
Default lock mode	Select the default lock mode: secure and unlocked.

Table 7-6

Field	Description
Door unlock time (sec.)	Specify the number of seconds this door can remain unlocked.
ADA unlock time (sec.)	Specify the number of seconds beyond the door unlock time that the lock can remain open for ADA users.
Door held time (sec.)	Specify the number of seconds that a door can be held open before an alarm is issued.
Maximum PIN attempts	Specify the maximum number of times a PIN can be entered incorrectly before an alarm is issued and the door is locked.
PIN length	Specify the length of the PIN in digits.
PIN failed lockout time (sec.)	Specify the number of seconds the door remains locked after the maximum number of attempts has occurred.
Enter PIN timeout (sec.)	Specify the number of seconds between PIN attempts.
Keypad enter key	Specify the character used to request entry after the PIN has been entered. # (pound) is the default.
REX unlocks door	Check this box to indicate that the door can be unlocked by a REX.
Enable PIN commands	Check this box to indicate that the user may enter PIN commands through the keypad.

**Note**

The EM-100 controller provides a PIN commands feature that enables an authorized badge holder to lock and unlock a reader which has a keypad, by entering a command at that reader. After a reader has been locked, no one will be granted access to the door's protected area until the reader is unlocked, even if they would normally be able to gain access. After a reader has been unlocked, the normal access rules are applied again. An example of using PIN commands is a roaming security guard who locks specific readers controlling areas that are off-limits after hours, and then unlocks them prior to normal working hours.

Two things must be configured before the PIN commands feature can be used:

- The appropriate readers must have the **Enable PIN commands** option enabled (on the **Door** page of the **Edit - Door** dialog)
- The badge of the appropriate users must have the **Allow PIN commands** option enabled (on the **Advanced EM-100** page of the **Add - Badge** dialog)

Then badge holders who are authorized to use PIN commands can enter the following command codes at those readers:

**00\*** - Lock the reader, so no one can use it to gain access until it is unlocked (by the 99\* command).

**99\*** - Unlock the reader, to restore normal access.

## Hardware Rules Door Property Sheet

When you select the **Hardware Rules** tab from the EM-100 door property sheet, a page like this appears:

The fields on this page include:

Field	Description
Set default mode by schedule	Check this box to indicate that this door is set to its default values at a specific time and indicates the disposition of the door outside of that schedule.
Schedule	From the drop-down list, indicate the time during which default mode is in effect for this door.
In-schedule mode	From the drop-down list, indicate the state for this door during the time indicated by the schedule.
Out-of-schedule mode	From the drop-down list, indicate the state for this door outside of the time indicated by the schedule.
PIN not required during schedule	Check this box to indicate that a PIN is NOT required during the specified schedule.
Schedule	From the drop-down list, indicate the time or schedule during which the PIN is not required for this door.
Change mode while input active	Check this box to indicate that the door can change mode while a specified input is active.
Input interface	From the drop-down list, select the interface that, when active, changes the mode of this door.



Field	Description
Input name	From the drop-down list, select the name of the input that changes the door mode when it goes active.
Input active mode	From the drop-down list, select the mode indicating the input is active.
only: / schedule:	Check only and indicate the schedule and condition if the mode change can occur only during specified times.
Momentarily unlock when input activated:	Check this box to indicate that the door should be momentarily unlocked when the input specified below is activated.
Input interface	From the drop-down list, select the interface that, when active, causes this door to momentarily unlock.
Input name	From the drop-down list, select the name of the input that causes this door to momentarily unlock.
only: / schedule:	Check and indicate the schedule and condition if the door can momentarily unlock only during certain times.
Disable forced alarm	Check this box then specify a time interval during which a forced alarm is disabled for this door.
Disable held alarm	Check this box then specify a time interval during which a held alarm is disabled for this door.

## Audit Records Door Property Sheet

When you select the Audit Records tab from an EM-100 door, a page like this appears:

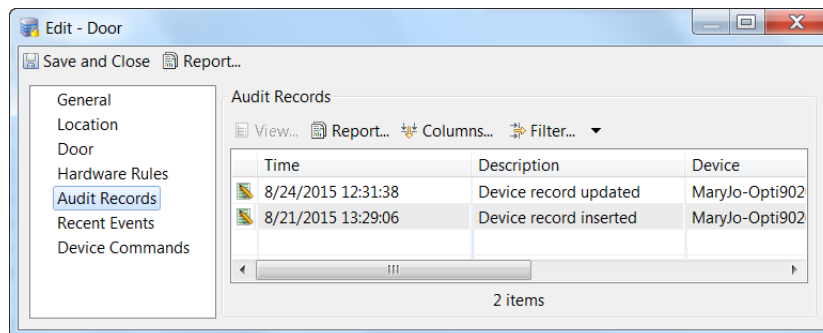

The columns on this page display the following information:

## Recent Events Door Property Sheet

When you select the **Recent Events** tab from the EM-100 door property sheet, a page like this appears:

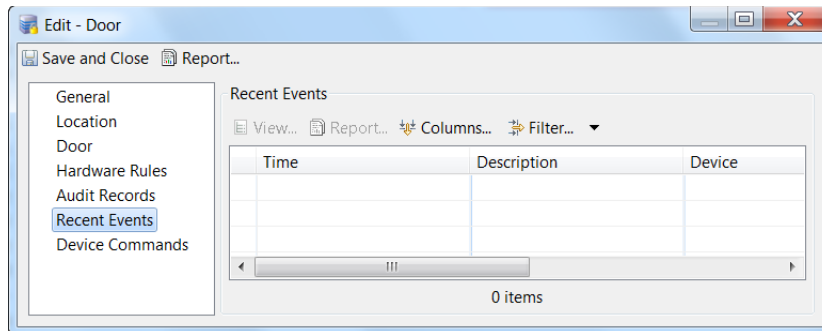

Button or Field	Description
View	When available, select a recent from the table then click this button to review a full explanation of the event for that device. You can also double-click the event in the table.
Report	Select a recent event from the table then click this button to generate a report.
Columns	Click this link and add or modify existing columns in the table. For more on this, refer to <a href="#">Revising the Column Display, page 3-14</a> .
Filter	Click this link to filter the events and display a subset of records. To change the number of viewable events, select Max rows. See <a href="#">Using Filters, page 3-12</a> .
Table	This table displays a list of all recent events currently available for this door.

## Device Commands Door Property Sheet

When you select the **Device Commands** tab on the EM-100 door property sheet, a page like this appears:

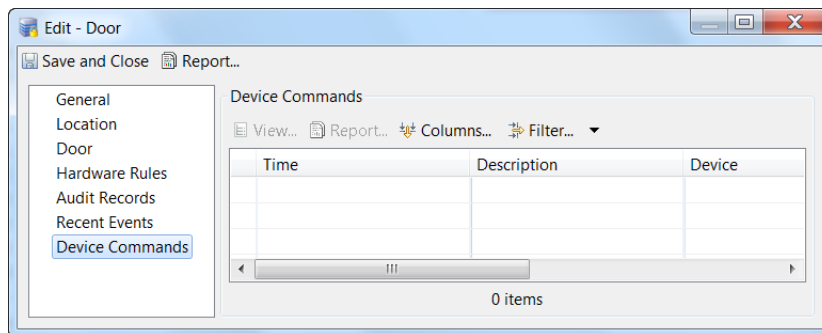

Button or Field	Description

## Device Commands

To access the following commands, right-click on the driver or module icon in the Hardware Tree module (select **Hardware Tree** from the **Doors** menu).

- [Reader Module Commands, page 7-46](#)
- [Input and Output Module Commands, page 7-47](#)

## Reader Module Commands

*Table 7-7 Reader Module (Module 00) Commands*

Command	Description
Reset Module	Resets the device.
Squelch	Suppresses any events from this module. Events are not reported or saved.
Unsquench	Undo squelch. Events are reported and saved.
View Recent Events	View a list of recent events for the module. See <a href="#">Viewing the Recent Events for a Device or Driver, page 5-17</a> .
Replace Module	Replaces the current module with new device. This command is active only when the device is disconnected from ICPAM (Unknown State). See <a href="#">Replacing a Gateway, page 6-54</a> .
Edit	Opens the Edit window to revise the device properties.
Edit Reader Connection Mode	Defines if the module supports connections for one or two readers. See the <i>Cisco Physical Access Gateway User Guide</i> for more information on reader connections.
Disable	Disables the device and all attached devices. Also disables referenced door configurations. See <a href="#">Disabling or Deleting a Door, page 7-16</a> . Disabled Devices can be re-enabled.
Delete	Permanently removes the device and all attached devices from the configuration. See <a href="#">Disabling or Deleting a Door, page 7-16</a> .
View Device Status	Opens a new window containing the Status and Extended Status information.
Show in Graphic Map Editor	Allows operators to add facility maps, and plot and organize devices for use in the Map viewer module. See <a href="#">Map Editor, page 12-55</a> .

## Input and Output Module Commands

Table 7-8 *Input and Output Module Commands*

Command	Description
Reset Module	Resets the device.
Squelch	Suppresses any events from this module. Events are not reported or saved.
Unsquench	Undo squelch. Events are reported and saved.
Replace Module	Replaces the current device with new device. This command is active only when the device is disconnected from ICPAM (Unknown State). The command is used to replace a faulty device. See <a href="#">Replacing a Gateway, page 6-54</a> .
View Recent Events	View a list of recent events for the module. See <a href="#">Viewing the Recent Events for a Device or Driver, page 5-17</a> .
Edit	Opens the Edit window to revise the device properties.
Disable	Disables the device and all attached devices. Also disables referenced door configurations. See <a href="#">Disabling or Deleting a Door, page 7-16</a> . Disabled Devices can be re-enabled.
Delete	Permanently removes the device and all attached devices from the configuration. See <a href="#">Disabling or Deleting a Door, page 7-16</a> .
View Device Status	Opens a new window containing the Status and Extended Status information.
Show in Graphic Map Editor	The Graphic Map Editor module allows operators to add facility maps, and plot and organize devices for use in the Map viewer module. See <a href="#">Map Editor, page 12-55</a> .

## Door Modes and Commands

### Door Modes

A door mode indicates the state of the door, including one of the following:

- **Open:** The door is physically held open. The lock is in Unlocked state, the door sensor is dis-engaged. When door is in Open mode, and a badge is presented to a reader, the badge data is read but may not be validated.
- **Close:** The door is physically closed. The lock is in Unlocked state and the door sensor is engaged, indicating door is closed. When the door is in Close mode, and a badge is presented, the badge data is read but may not be validated.
- **Lock:** The door is physically closed and the lock is in Locked state. The Door Sensor is engaged. When the door is in Lock mode, and a badge is presented, the badge data is read and validated: if access is granted the lock is opened, access is denied if the badge is invalid.

- **Secure:** The door is locked and the deadbolt is applied. The deadbolt remains in place until issue a command to change the door mode (such as **Reset Door Mode**). See [Door Commands, page 7-48](#) for more information.

**Tip**

For more information, see [Understanding Door Modes, Door Schedules, and the First Unlock Feature, page 5-28](#).

## Door Commands

The following commands are available when you right-click a door configuration in the device or locations view (available in either **Hardware Tree** or **Doors & Locations**).

**Table 7-9** *Door Commands in Locations View*

Command	Description
Grant Access	Grants access to the door.
Grant Access ADA	Grants access to a door, and applies the ADA settings, such as the amount of time the door is held open, or use of a mechanical swing device. See <a href="#">Door Configuration Properties, page 8-28</a> for more information.
Update State	Updates the door state displayed in the hardware tree.
Set Door Mode Lock	<p>Overrides the current door mode and locks the mechanism. The door mode remains set to Lock until you do one of the following:</p> <ul style="list-style-type: none"> <li>• Select the command <b>Reset Door Mode</b> to return the door to the configured mode (such as the default mode or scheduled mode).</li> <li>• Select a different <b>Set Door Mode</b> command.</li> <li>• Reset the Gateway using the <b>Reset Gateway</b> command. You can also reboot the Gateway.</li> <li>• Successfully execute the <b>Reload Gateway Configuration</b> command.</li> <li>• Invoke the <b>Apply Configuration Changes</b> command (if no configuration changes were made, then no changes are sent to the Gateway. The previous door mode still applies).</li> </ul> <p><b>Note</b> Badge access is still allowed, or you can manually grant access with the <b>Grant Access</b> command.</p>

Table 7-9 Door Commands in Locations View (continued)

Command	Description
Set Door Mode Open	<p>Overrides the current door mode and unlocks the mechanism. The door mode remains set to Unlock until you do one of the following:</p> <ul style="list-style-type: none"> <li>• Select the command <b>Reset Door Mode</b> to return the door to the configured mode (such as the default mode or scheduled mode).</li> <li>• Select a different <b>Set Door Mode</b> command.</li> <li>• Reset the Gateway using the <b>Reset Gateway</b> command. You can also reboot the Gateway.</li> <li>• Successfully execute the <b>Reload Gateway Configuration</b> command.</li> <li>• Invoke the <b>Apply Configuration Changes</b> command (if no configuration changes were made, then no changes are sent to the Gateway. The previous door mode still applies).</li> </ul> <p><b>Note</b> Badge access is still allowed, or you can manually grant access with the <b>Grant Access</b> command.</p>
Set Door Mode Secure	<p>If a door includes a deadbolt device, this command overrides the door mode and applies the deadbolt. The deadbolt remains in place until you do one of the following:</p> <ul style="list-style-type: none"> <li>• Select the command <b>Reset Door Mode</b> to return the door to the configured mode (such as the default mode or scheduled mode).</li> <li>• Select a different <b>Set Door Mode</b> command.</li> <li>• Reset the Gateway using the <b>Reset Gateway</b> command. You can also reboot the Gateway.</li> <li>• Successfully execute the <b>Reload Gateway Configuration</b> command.</li> <li>• Successfully execute the <b>Apply Configuration Changes</b> command (if no configuration changes were made, then no changes are sent to the Gateway. The previous door mode still applies).</li> </ul> <p><b>Note</b> Badge access is still allowed, or you can manually grant access with the <b>Grant Access</b> command.</p>
Reset Door Mode	Resets the door to the configured default mode.
Set Admin Down	Places the door in the Down state.
Set Admin Up	Places the door in the Up state.

Table 7-9 Door Commands in Locations View (continued)

Command	Description
Activate Access Policies	Manually activates the access policies for one or more doors. Use this command if the access policies were deactivated.
Deactivate Access Policies	<p>Manually deactivates all access policies for one or more doors. All access is denied.</p> <p>Activate/deactivate access policies for multiple doors:</p> <ul style="list-style-type: none"> <li>• Select <b>Door/Location-based Hardware</b> from the Doors menu, right click a location and select <b>Deactivate Access Policies</b>. All doors in that location are affected.</li> </ul> <p>Activate/deactivate access policies for a single door:</p> <ul style="list-style-type: none"> <li>• Right-click a door icon in the <b>Door/Location-based Hardware</b> module and select the command.</li> <li>• In the <b>Hardware Tree</b> module, expand the Physical Driver device tree, right-click a door and select the command.</li> </ul> <p>To reactive the access policies, select <b>Activate Access Policies</b>.</p>



## Configuring Door and Device Templates

---

This chapter describes how to create and modify door and device templates. Device templates define common settings for device types, such as gateways, readers and locks. Door templates define common settings for door configurations, including the devices that are attached to the door.

See [Chapter 5, “Understanding Controller and Door Configurations”](#) for more information.

### Contents

- [Configuring Door Templates, page 8-2](#)
- [Configuring Device Templates, page 8-11](#)
- [Configuring Credential Templates, page 8-15](#)
- [Configuring Reader LED Profiles, page 8-24](#)
- [Duplicating Templates, page 8-26](#)
- [Door Configuration Properties, page 8-28](#)
- [Device Configuration Properties, page 8-30](#)
- [Debounce Timer, page 8-35](#)

# Configuring Door Templates

Use door templates to define sets of hardware that can be applied to multiple doors. For example, you can create a template that includes a door swing for use with ADA-enabled doors, or a dead bolt for doors that require extra security. See [Chapter 5, “Understanding Controller and Door Configurations”](#) for more information.

**Figure 8-1** Door Templates main window

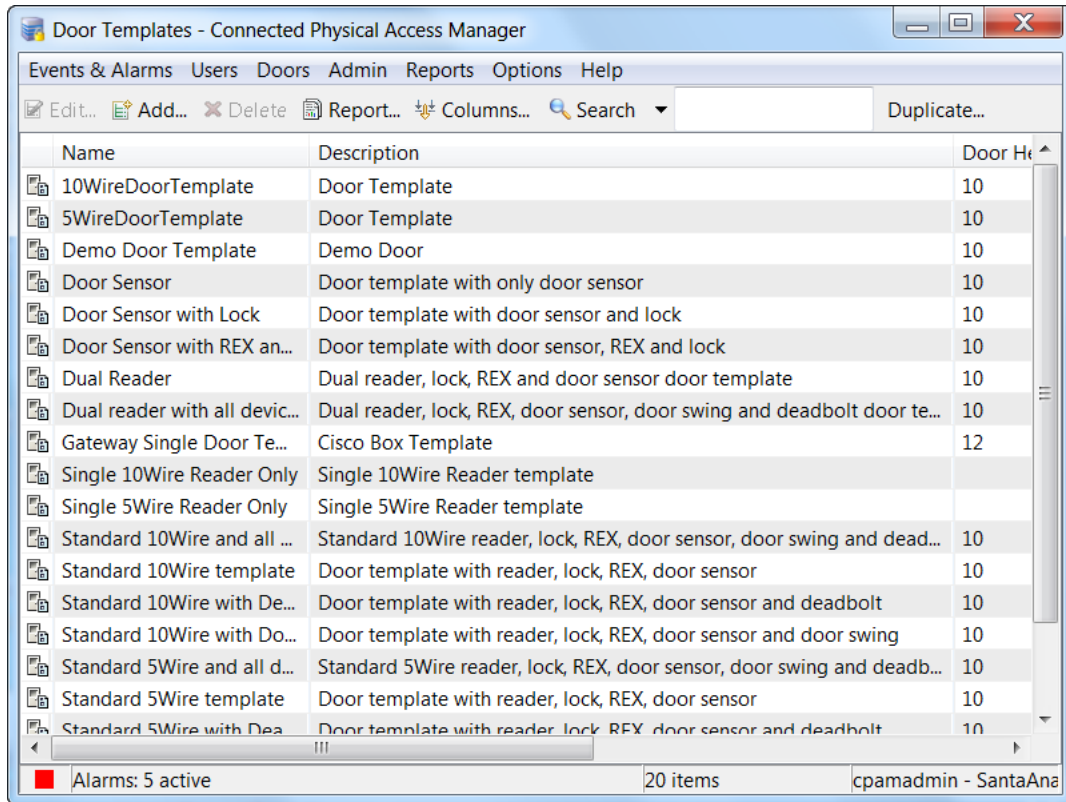

## Note

The default templates are read-only. Only user-created door templates can be modified.

To create or modify a door template, do the following:

- Step 1** Choose the **Doors > Templates > Door Templates** command from the menu bar of an ICPAM module.

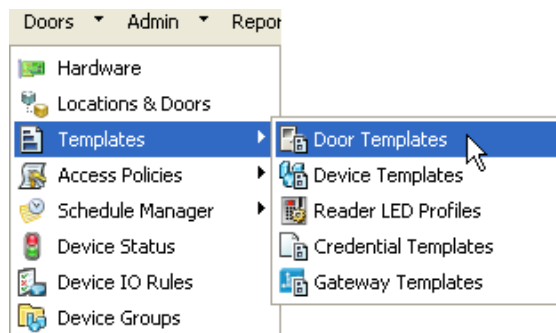

**Step 2** On the resulting **Door Templates** window, either:

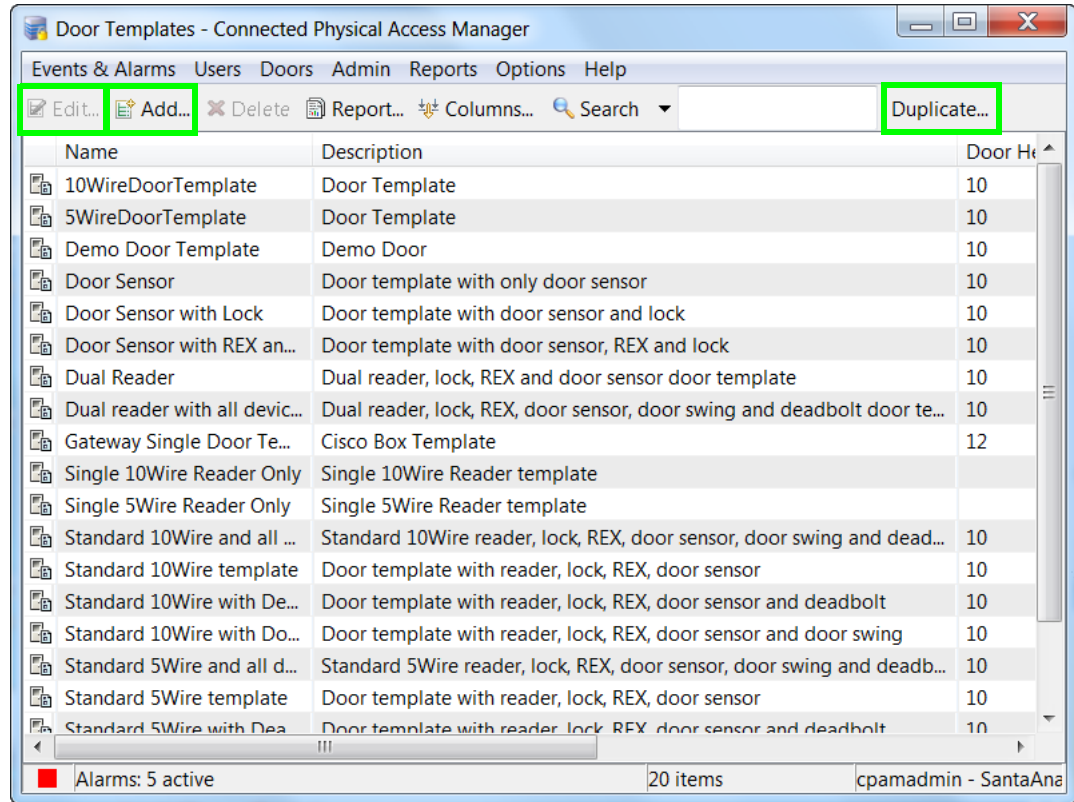

- click the **Add** button on the toolbar
- click on an existing template in the table, and click the **Edit** or **Duplicate** button on the toolbar
- right-click on an existing template in the table, and choose the **Add**, **Edit**, or **Duplicate** command from the pop-up menu

To duplicate an existing template:

- Select the template in the table, and click the **Duplicate** button on the right side of the toolbar.
- In the resulting dialog, enter a **New Name** for the new template, and click **OK**.
- Back in the **Door Templates** window, select the duplicate template name in the table, and click the **Edit** button on the toolbar.
- Revise the template settings, as described in the remaining steps of this procedure.

**Step 3** In the resulting window (**Add - Door Template** in this example), click the **General** tab (in the left pane) and type the **Name** and **Description** for this template.

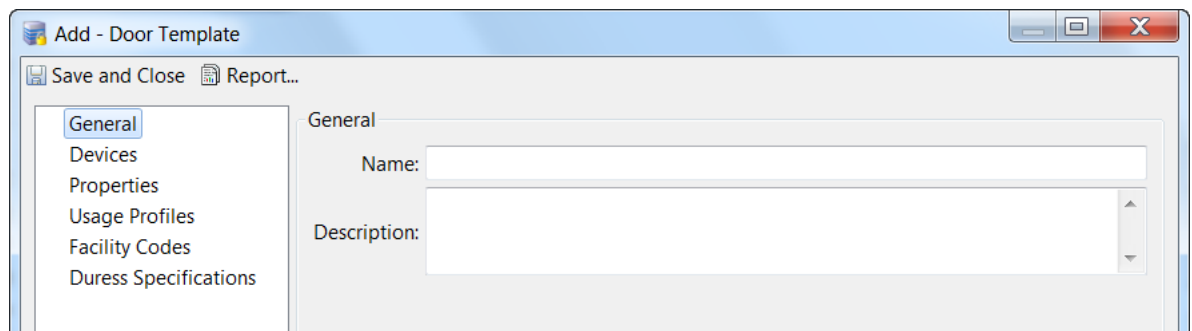

- Step 4** Select the devices for this door template:
- Select the **Devices** tab (in the left pane).
  - Either select an existing device from the list and click the **Edit** button, or click the **Add** button (to add a new device).
  - Select the **Device Type**. For example: Lock, Reader, etc.
  - Select the device **Template**. Only the templates for the selected device type are displayed. For example, if the selected device type is Reader, then only reader templates are displayed. See [Configuring Device Templates, page 8-11](#) for instructions about how to create and modify the available templates.
  - Click **OK**.
  - To add another device, repeat steps **b** through **e**.

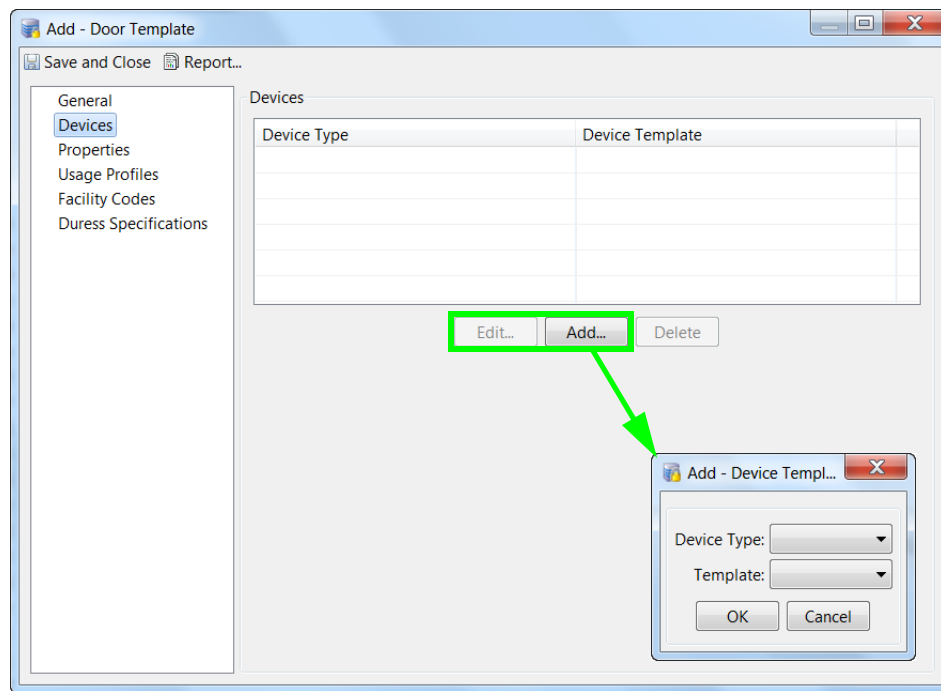

- Step 5** Define the door lock properties.
- Select the **Properties** tab (in the left pane).
  - Relock interval time (sec)**: the number of seconds to keep the door open after an access request is granted (grant access).
  - Door held open time (sec)**: the number of seconds before the `DoorHeldOpen` alarm is generated.
  - Door lock on close**:
    - The default is **Yes**. The door will always lock when closed, overriding the **Relock interval time** (even if a second request was entered while the door was open).
    - Select **No** to keep the door unlocked for the duration of the **Relock interval time**, even if it is closed. The relock time is based on the most recent access request for the door.

- e. **Deadbolt engage delay (sec):** the delay (in seconds) after a door closes until the deadbolt is applied.

The screenshot shows the 'Add - Door Template' window with the 'Properties' section highlighted. The fields in the highlighted section are:

- Relock time interval (sec):
- Door held open time (sec):
- Door lock on close:  Yes  No
- Deadbolt engage delay (sec):

#### Usage Notes

By default, when a door access request is granted, the door remains unlocked until the **Relock interval time** elapses, or until the door is closed again, whichever comes first. In some situations, you may want to keep the door unlocked for the entire interval time, even when it is closed again. For example:

1. When a door is unlocked by user "A" the **Relock interval time** is triggered. The door will automatically relock when the relock time is met, or when the door is open and then closed again.
2. Before user "A" approaches the door and opens it, a handicapped person, user "B", also presents a badge. Access is granted and the **Relock interval time** is extended to reflect this latest grant access request.
3. In the meantime, however, user "A" opens the door and closes the door behind him (while user "B" is several feet away from the door). The door is automatically relocked since **Door lock on close** is set to **Yes** by default.
4. To keep the door unlocked until the **Relock interval time** is elapsed for the most recent request, set **Door lock on close** to **No**.

**Step 6** Define the door mode and schedule:

The screenshot shows the 'Add - Door Template' window with the 'Properties' tab selected. The left sidebar contains a tree view with 'Properties' highlighted. The main area contains various configuration fields. A green box highlights the following fields:

- Scheduled door mode: [Dropdown menu]
- Door enable schedule: [Dropdown menu]
- First unlock:  Yes  No
- Default mode: [Dropdown menu]

Other visible fields include: Relock time interval (sec): [Text box], Door held open time (sec): [Text box], Door lock on close:  Yes  No, Deadbolt engage delay (sec): [Text box], If badge not in gateway: [Dropdown menu], Access decision on timeout: [Dropdown menu], If server unreachable: [Dropdown menu], Server access timeout (sec): [Text box], If server unreachable (APB): [Dropdown menu], ADA timespec multiplier: [Text box], Door swing activation delay(sec): [Text box], and Door swing usage: [Dropdown menu].

- a. **Default mode:** select the default door mode. The door remains in this mode at all times except when a schedule is defined.
  - *Open*: the door is held open and the lock is in unlocked state.
  - *Close*: the door is physically closed and the lock is in unlocked state.
  - *Lock*: the door is physically closed and the lock is in Locked state.
  - *Secure*: the door is locked and the deadbolt is applied.

For more information, see [Door Modes, page 7-47](#).

- b. **Door enable schedule:** (optional) select a door schedule. If you select **None**, then the door will remain in the **Default** mode at all times. If you select a schedule, the schedule will override the default mode for the times and days defined in the schedule. See [Using the Schedule Manager, page 11-9](#) to add or modify the available door schedules.
- c. **Scheduled door mode:** select the door mode when the door scheduled is applied.
 

For example if the Default mode is Lock, and the scheduled door mode is Close, then the door will be locked at all times except during the hours and days defined by the schedule selected in *Door enable schedule*.
- d. **First Unlock:** select **First Unlock** to activate the door schedule only on the first successful badge swipe. The door remains in default mode until a badge is used to access the door, even after the beginning time for the schedule. This is useful in situations such as snow days to ensure the door is not opened until a badge holder is physically present.



Tip

For more information, see [Understanding Door Modes, Door Schedules, and the First Unlock Feature](#), page 5-28.

**Step 7** Specify the remaining door **Properties**:

The screenshot shows the 'Add - Door Template' dialog box with the 'Properties' tab selected. The following fields are highlighted with a green box:

- If badge not in gateway: [Dropdown]
- Access decision on timeout: [Dropdown]
- If server unreachable: [Dropdown]
- Server access timeout (sec): [Text]
- If server unreachable (APB): [Dropdown]
- ADA timespec multiplier: [Text]
- Door swing activation delay(sec): [Text]
- Door swing usage: [Dropdown]

- **If badge not in gateway:** the action taken by the gateway if the badge is not in the gateway database.



Note

Starting with the ICPAM 2.1 release, the **If the badge not in gateway** property is set to **Use Server** by default. This enables the badge to be authenticated if it is present in ICPAM even when it does not exist in the gateway. This option is enabled by default for new installations. Customers upgrading from CPAM can manually change this option in the door properties, if desired.

- **Access decision on timeout:** the action taken by the gateway if there is no response within *Server access timeout*.
- **If server unreachable:** the action to be taken by gateway in case it cannot reach ICPAM. See the [“Using Local \(Controller\) Credentials if Network Communication is Lost”](#) section on page 11-24.
- **Server access timeout (sec):** the number of seconds before an action is taken based on *Access decision on timeout*.
- **If server unreachable (APB):** the action to be taken by a gateway which is part of an anti-passback area in case it cannot reach the ICPAM server.
- **ADA timespec multiplier:** the multiplier used on *Relock interval time* if an ADA access occurs.

- **Door swing activation delay (sec):** the number of seconds before the door swing is activated. This setting allows time for the door lock or other devices to activate before the mechanical door swing activates.
- **Door swing usage:**
  - **Always operate:** the door swing activates for all access requests.
  - **Operate for ADA only:** the door swing operates only for requests from an ADA device.
  - **Do not operate:** the door swing does not operate.

**Step 8** Specify the door **Usage Profiles** used by the reader device(s). These profiles define what LED or buzzer action occurs under the following events:

- **Grant access:** the LED display when normal access is granted.
- **Grant access ADA:** the LED display when access is granted for an ADA enabled badge.
- **Deny access:** the LED display when access is denied.
- **Grant access facility code:** the LED display when access is granted based on a Facility Code.
- **Mode open:** the LED display when the door mode is *Open*.
- **Mode close:** the LED display when the door mode is *Close*.
- **Mode lock:** the LED display when the door mode is *Lock*.

The screenshot shows a software window titled "Add - Door Template". At the top, there are buttons for "Save and Close" and "Report...". On the left side, there is a vertical navigation pane with the following items: "General", "Devices", "Properties", "Usage Profiles" (which is highlighted with a blue selection bar), "Facility Codes", and "Duress Specifications". The main area of the window is titled "Usage Profiles" and contains seven rows of dropdown menus, each with a label and a downward-pointing arrow:

- Grant access:
- Grant access ADA:
- Deny access:
- Grant access facility code:
- Mode open:
- Mode close:
- Mode lock:



**Tip**

For more information, see [Configuring Reader LED and Buzzer Profiles, page 8-24](#).



**Step 9** Specify the **Facility Codes** information.

Click **Add** to open a dialog that enables you to specify a credential template and facility code.

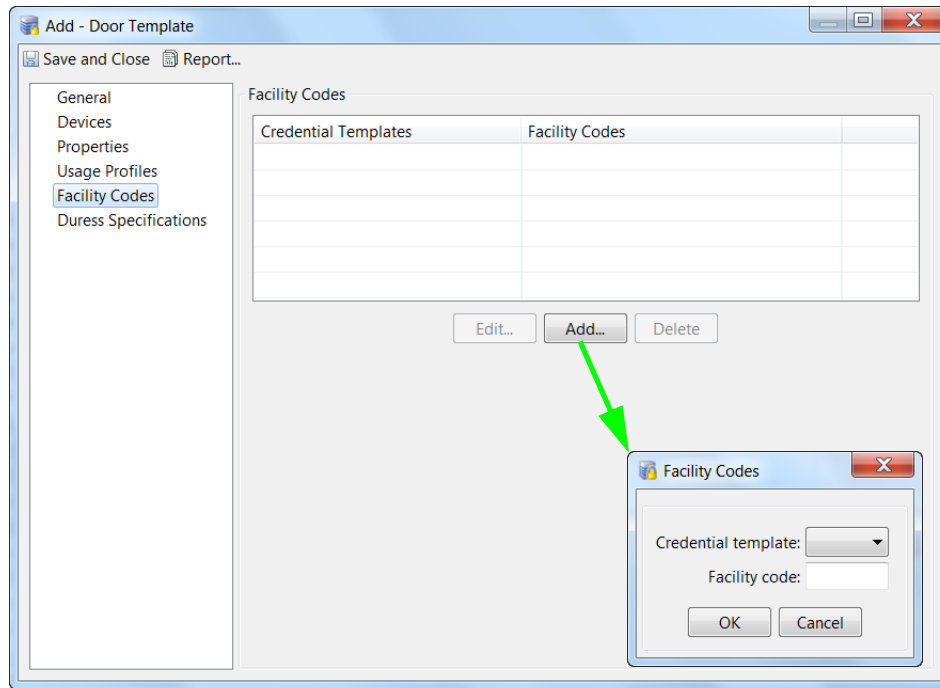

Each card format has a facility code associated with the card. All the card formats that will be used with the door must be specified. The gateway can also be configured to use facility codes during *Server Unreachable* and *Server Access Timeout* if necessary.

**Step 10** Specify the **Duress Specifications**.

Click **Add** to open a dialog that enables you to specify an alarm type and duress code.

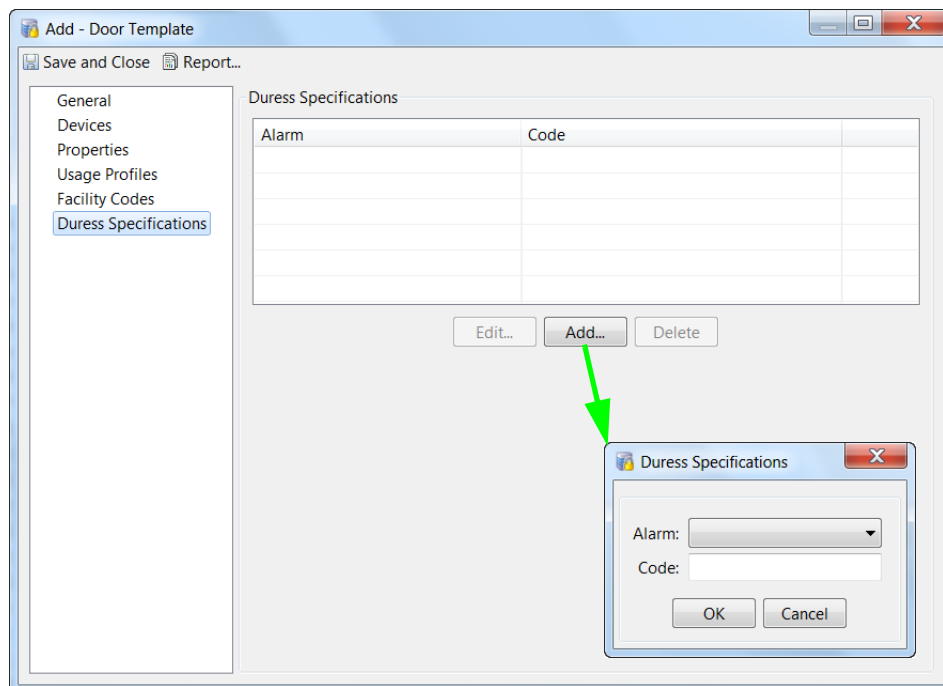

**Step 11** Click the **Save and Close** button to save the changes to the template and close the window.

---

# Configuring Device Templates

Device templates are pre-defined configurations for the device types using in door configurations. Device templates are used to create door templates or they can be applied directly to a gateway interface. This section includes instructions on how to create device templates.



Note

Most settings in the default templates are read-only. Only user-created door templates can be modified.

Figure 8-2 Device Templates main window

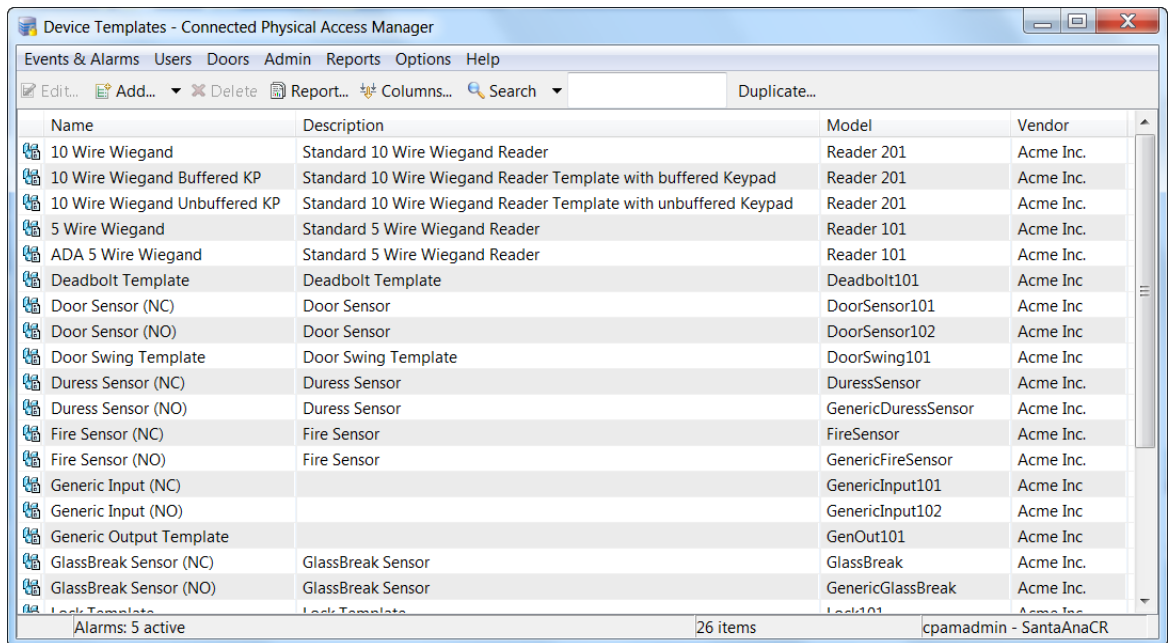

For more information, see [Chapter 5, “Understanding Controller and Door Configurations”](#) and [Chapter 7, “Configuring Doors”](#).

## Creating a Device Template

Use the Device Template Wizard to create a new device template.

**Step 1** Choose the **Doors > Templates > Device Templates** command.

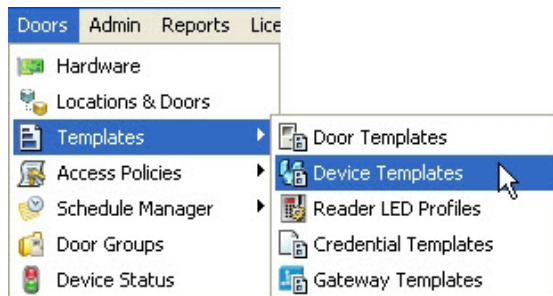

**Step 2** On the resulting **Device Templates** window, click the **Add...** button in the toolbar, and then select **Device Template Wizard**.

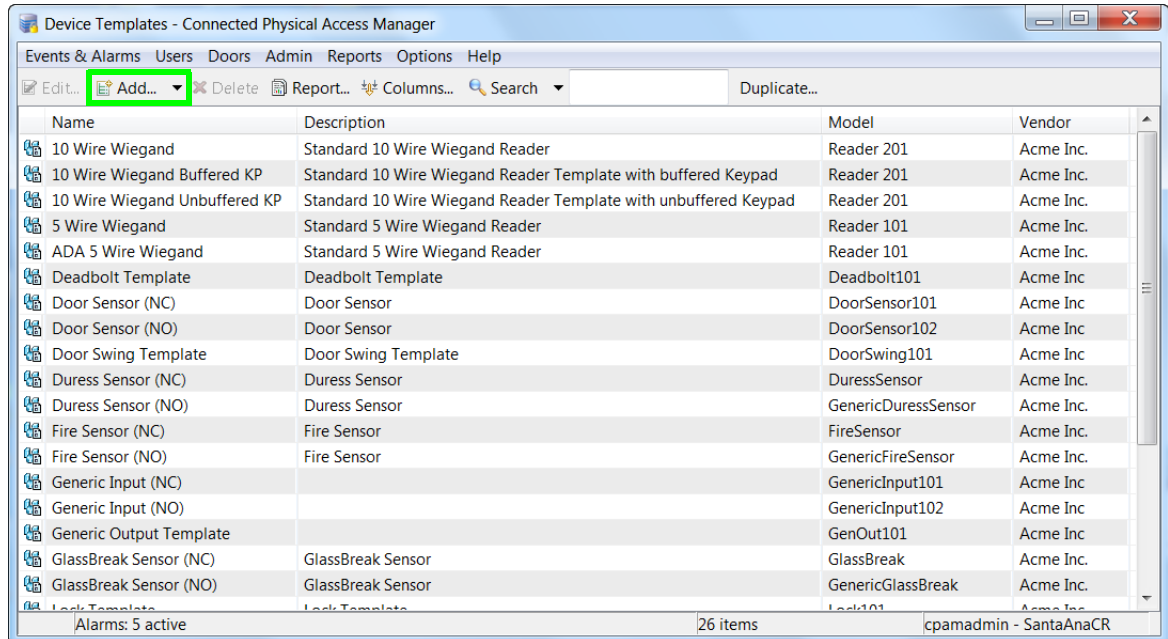

You can also do the following on this window:

- Right-click on a device template's Name in the table, to access the **Edit** and **Delete** commands in the pop-up menu.
- Click on an existing device template in the table, and then click on the **Edit** or the **Duplicate** button.

To duplicate an existing device template:

- Select the template in the table, and click the **Duplicate** button on the right side of the toolbar.
- In the resulting dialog, enter a **New Name** for the new template, and click **OK**.
- Back in the **Device Templates** window, select the duplicate template name in the table, and click the **Edit** button on the toolbar.
- Revise the template settings, as described in the remaining steps of this procedure.

**Step 3** On the **Choose Device Template** page of the Create New Device Template wizard, select the **Device template type**, and then click **Next**.

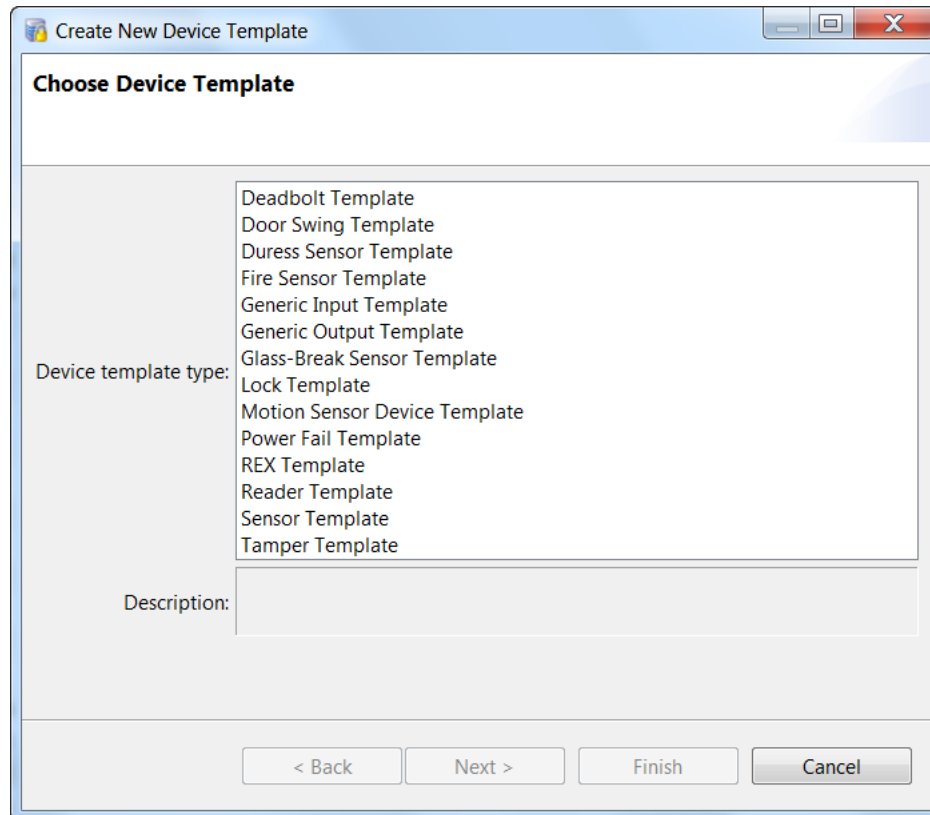

The screenshot shows a window titled "Create New Device Template" with a sub-header "Choose Device Template". The window contains a list of device template types and a description field.

Device template type:

- Deadbolt Template
- Door Swing Template
- Duress Sensor Template
- Fire Sensor Template
- Generic Input Template
- Generic Output Template
- Glass-Break Sensor Template
- Lock Template
- Motion Sensor Device Template
- Power Fail Template
- REX Template
- Reader Template
- Sensor Template
- Tamper Template

Description:

< Back   Next >   Finish   Cancel

- Step 4** On the resulting page of the wizard, specify the device settings. The set of fields that appear vary depending on the device type, which in this example is a REX (Request to EXit) device.

The screenshot shows a window titled "Create New Device Template" with a sub-header "Configure REX Template". The form includes the following fields:

- Name: [Text input field]
- Model: [Dropdown menu]
- Vendor: [Text input field]
- Description: [Text area]
- REX input: [Dropdown menu]
- Device state: [Dropdown menu]
- Supervised:  Yes  No
- Push button:  Yes  No
- Push button type: [Dropdown menu]

At the bottom of the window, there are four buttons: "< Back", "Next >", "Finish", and "Cancel".

- Type the device template's **Name**.
- Specify the other device settings. See [Device Configuration Properties, page 8-30](#) for detailed information about the options for each device type.
- Click **Finish** to save the new device template and close the wizard.

# Configuring Credential Templates

Credential templates define the settings for credential devices, such as Wiegand readers and keypads. Credential templates are applied to reader devices or to door templates.

- [Overview, page 8-15](#)
- [Credential Templates Settings Summary, page 8-17](#)
- [Creating a Gateway Credential Template, page 8-18](#)
- [Creating a Virtual Credential Template, page 8-20](#)

## Overview

When an access control card is presented to a reader, the reader reads a set of bits. The reader needs to know how to interpret the bits, how to validate the data, and how to extract relevant card information. Credential Templates specify the card data format for a reader, and are used to configure reader device templates.

The data specification include the following:

- Card data fields and data range
- Parity bits and their bit position for data validation
- Marker bits and their bit positions/range using sentinels

Each credential template has Primary and Secondary Data fields to determine how the card data is extracted. See [Credential Templates Settings Summary, page 8-17](#) for a configuration overview.

Existing templates cannot be modified.

- For instructions about how to create a new credential template for a **Cisco gateway controller**, see [Creating a Gateway Credential Template, page 8-18](#).
- For instructions about how to create a new credential template for an **Identiv EM-100 controller**, see [Creating a Virtual Credential Template, page 8-20](#).

Figure 8-3 Credential Templates main window

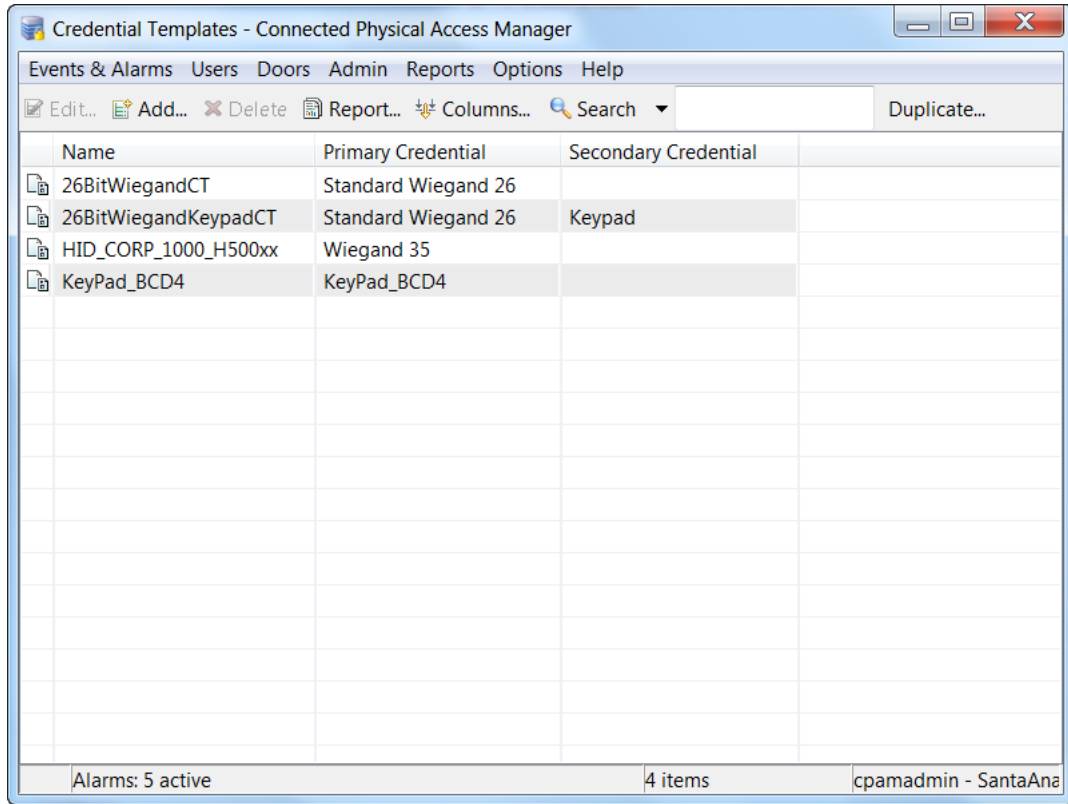



## Credential Templates Settings Summary

ICPAM supports credential templates for the following categories of readers:

- [Wiegand Keypad](#)
- [Wiegand](#)
- [Keypad](#)

The template is based on the type of Reader.

**Note**

Credential templates with the same length in bits for the Primary data cannot be associated with the same reader device; the templates must be associated with different devices. However, credential templates with different length in bits for the Primary data can be associated with the same reader device.

### Wiegand Keypad

The keypad data is transported using the Wiegand protocol (when the user enters a PIN on the keypad, the data is transported to the reader in the Wiegand frame). The credential template has two decoding configurations.

- The first decoding configuration (Primary) specifies how to extract the PIN data entered by the user.
- Once the PIN data is extracted, the second decoding configuration (Secondary) specifies how to extract each PIN, by specifying the total length, length of each PIN, parity, etc.

An example of a credential template for this type of reader is the `26BitWiegandKeypadCT`.

### Wiegand

Card data is transported over Wiegand protocol. When the user swipes or flashes the badge, the card data is transported to the reader in the Wiegand frame. Only the first decoding configuration (Primary) is required to specify the extraction of card data fields such as Card ID, Facility, Location, and Other. Parity and sentinel are used to validate the data.

An example of a credential template for this type of reader is the `26BitWiegandCT`.

### Keypad

The keys pressed by a user are directly transported to the reader, so only the Primary decoding configuration is required.

An example of a credential template for this type of reader is the `KeyPad_BCD4`.

## Creating a Gateway Credential Template

Perform the following steps to create, edit, or duplicate a credential template for a Cisco gateway controller.

**Step 1** Choose the **Doors > Templates > Gateway Credential Templates** command.

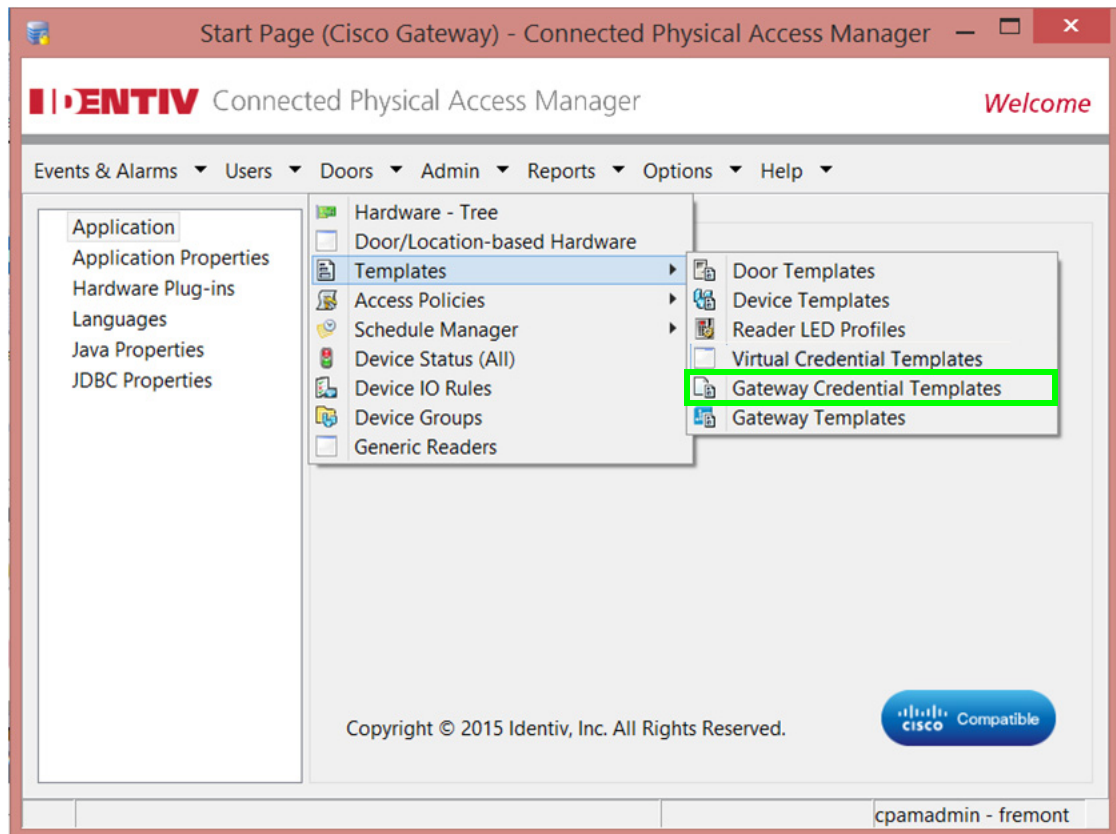

**Step 2** In the resulting **Credential Templates** window, either:

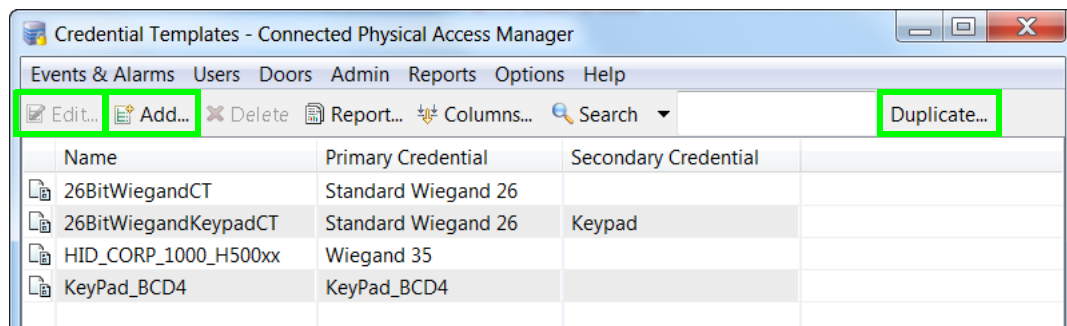

- click the **Add** button on the toolbar
- click on an existing template in the table, and click the **Edit** or **Duplicate** button on the toolbar
- right-click on an existing template in the table, and choose the **Add**, **Edit**, or **Duplicate** command from the pop-up menu

To duplicate an existing credential template:

- Select the template in the table, and click the **Duplicate** button on the right side of the toolbar.
- In the resulting dialog, enter a **New Name** for the new template, and click **OK**.
- Back in the **Credential Templates** window, select the duplicate template name in the table, and click the **Edit** button on the toolbar.
- Revise the template settings, as described in the remaining steps of this procedure.

**Step 3** In the resulting window (**Add - Credential Template** in this example), click the **General** tab (in the left pane), type the **Name**, and select the **Type** for this template.

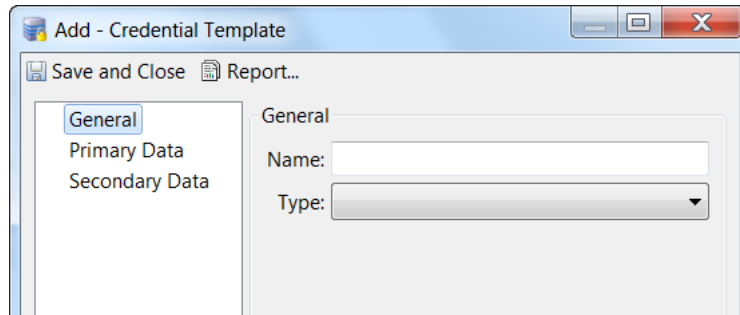

**Step 4** Specify the **Primary Data** and the **Secondary Data** settings for the template. See [Credential Templates Settings Summary, page 8-17](#) for more information.

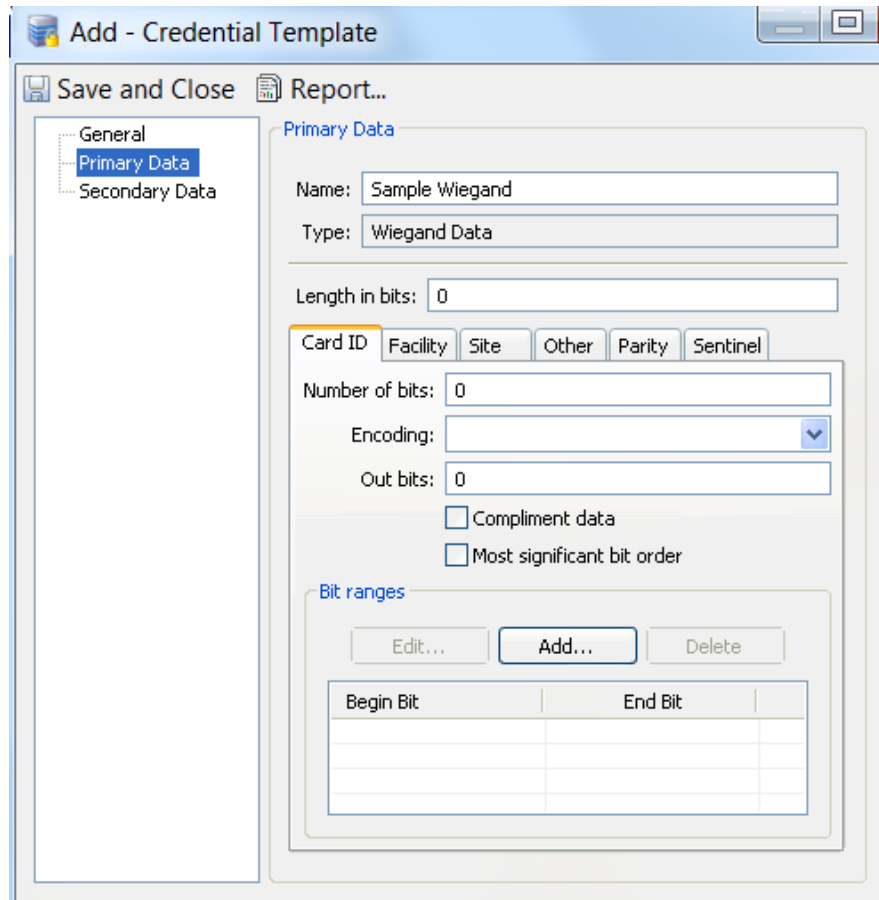



**Note** Credential templates with the same length in bits for the Primary data cannot be associated with the same reader device; the templates must be associated with different devices. However, credential templates with different length in bits for the Primary data can be associated with the same reader device. The value for the field **length in bits** should be a number between 1 and 2147483647.

**Step 5** Click **Save and Close** to save the template and close the window.

## Creating a Virtual Credential Template

Perform the following steps to create, edit, or duplicate a virtual credential template which is used to populate credentials for Identiv EM-100 controllers.

**Step 1** Choose the **Doors > Templates > Virtual Credential Templates** command from the menu bar.

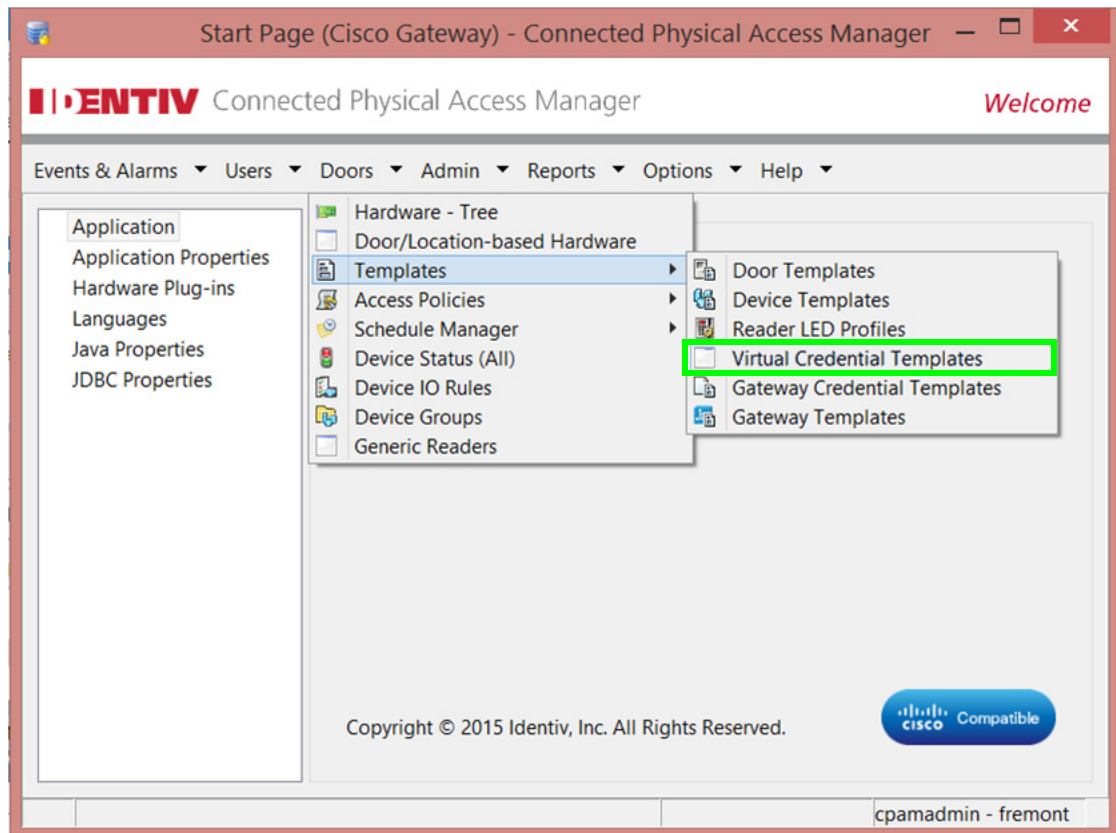

**Step 2** Click **Add**, or select an existing template from the list and click **Edit**.

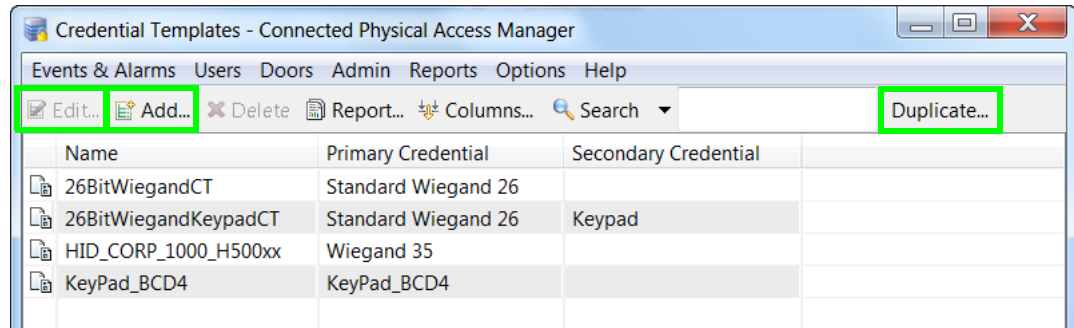

- You can also select an existing device from the list and click **Edit** or **Duplicate**. To duplicate an existing template:
  - Select the template and click the **Duplicate** button in the upper right.
  - Enter a **New Name** for the template and click **OK**.
  - In the main window, select the duplicate template name and click **Edit**.
  - Revise the template settings as described in the following steps.
- You can also or right-click on a template name to access the **Add**, **Edit** and **Delete** functions.

**Step 3** In the resulting window (**Add - Credential Template** in this example), click the **General** tab (in the left pane), type the **Name**, and select the **Type** for this template.

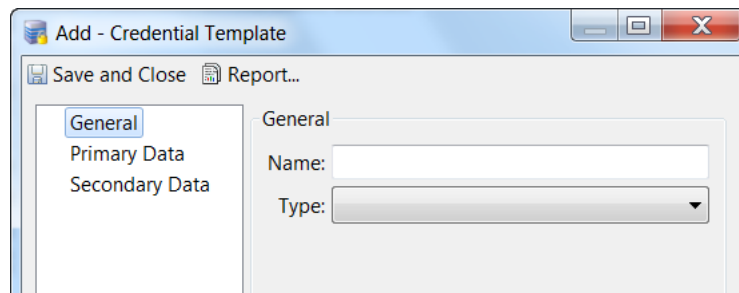

**Step 4** Enter the **Primary Data** and **Secondary Data** settings for the template.

See [Credential Templates Settings Summary, page 8-17](#) for more information.

The screenshot shows the 'Add - Credential Template' window. On the left, a tree view shows 'General', 'Primary Data' (selected), and 'Secondary Data'. The main area is titled 'Primary Data' and contains the following fields and controls:

- Name: Sample Wiegand
- Type: Wiegand Data
- Length in bits: 0
- Tabs: Card ID (selected), Facility, Site, Other, Parity, Sentinel
- Number of bits: 0
- Encoding: (dropdown menu)
- Out bits: 0
- Compliment data
- Most significant bit order
- Bit ranges section with buttons: Edit..., Add..., Delete
- Table with columns: Begin Bit, End Bit



**Note** Credential templates with the same length in bits for the Primary data cannot be associated with the same reader device; the templates must be associated with different devices. However, credential templates with different length in bits for the Primary data can be associated with the same reader device. The value for the field **length in bits** should be a number between 1 and 2147483647.

**Step 5** Click **Save and Close** to save the template and close the window.

For more about this, refer to [Importing New Credential Templates from VFF Files, page 8-23](#).

## Importing New Credential Templates from VFF Files

Identiv supplies a variety of VFF files that can be used for creating dozens of credential types.

To import credential templates from VFFs:

- 
- Step 1** Download one or more VFFs from the following page of the Identiv Web site:  
<http://www.identiv.com/icpam-credential-templates>
- Step 2** In the ICPAM hardware tree, right-click on the EM-100 Driver and select **Edit**.  
The EM-100 driver property sheets appear ([Identiv EM-100 Driver Property Sheets, page 6-62](#)).
- Step 3** Click to select the EM-100 Credential Template property sheet (see [Driver EM-100 Credential Templates Page, page 6-65](#)).
- Step 4** Click **Add**.
- Step 5** Select **Wiegand** as the type and click **OK**.

The Add EM-100 Credential Template screen appears.

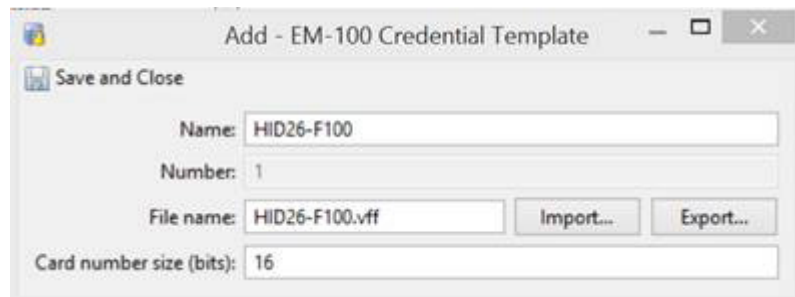

- Step 6** In the 'Name' field, enter an appropriate name for this credential template.
- Step 7** Click **Import...**
- Step 8** Browse to the VFF file you downloaded from the Identiv site.
- Step 9** In the 'Card number size (bits)' field, enter the number of bits required for this card number format.  
The value should be a number between 1 and 2147483647.
- Step 10** Click **Save and Close**.

The new credential template now appears in the credential template window.

---

# Configuring Reader LED Profiles

**Reader LED Profiles** define the LED lights and buzzer on the reader interface of a Gateway or Reader module. The profiles are used to configure the Usage Profiles in door templates. The profiles can also be applied to reader interfaces in the Hardware Tree module.

Figure 8-4 Reader UI Profile Main Window

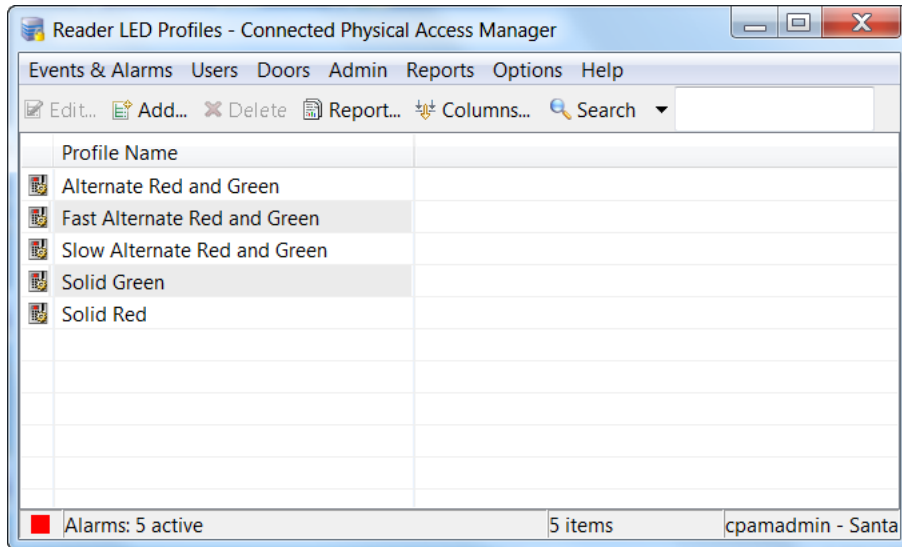

## Configuring Reader LED and Buzzer Profiles

The reader interface provides up to three output lines to control connections for LEDs or a buzzer. A typical reader includes connections for the red LED, green LED and a buzzer. Most readers use only one or two of these.

Complete the following instructions to configure LED profiles.

- Step 1** Select **Reader LED Profiles** from the Doors menu, in the **Templates** submenu.

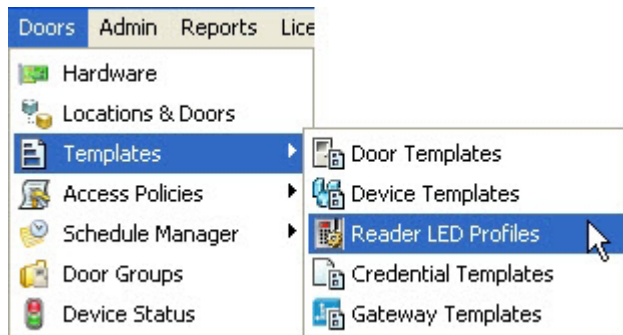

- Step 2** Create or edit the profile:
- a. Click **Add**, or select an existing profile and click **Edit**.





**Tip** You can also right-click on an item to access the **Add**, **Edit** and **Delete** functions.

- b. Enter the profile **Name**.
- c. Enter the profile settings:
  - **Command**: defines the state of the output when the profile is invoked (**Output On** or **Output Off**).
  - **Duration**: specifies how long the output is turned on and off.
  - **Repeat**: specifies the number of times the output is turned on and off.
  - **On time (ms)** and **Off time (ms)**: specifies how long the output is ON or OFF, in milliseconds.

**Step 3** Click **Save and Close** to save the profile and close the window.

# Duplicating Templates

- Duplicating Door, Device, and Credential Templates, page 8-26
- Duplicating Gateway Templates, page 8-27

## Duplicating Door, Device, and Credential Templates

In situations where you need a template that is similar to an existing template, use the Duplicate feature to create an exact copy of the template, and then edit the new template settings as necessary.

To create exact duplicates of door, device, and credential templates, do the following:

- Step 1** Select Templates from the Doors window and select a template type: Door, Device, or Credential.
- Step 2** Highlight an existing template entry.
- Step 3** Click the **Duplicate** button in the upper right of the window, as shown in [Figure 8-5](#).

**Figure 8-5** Duplicate button in the Door Templates window

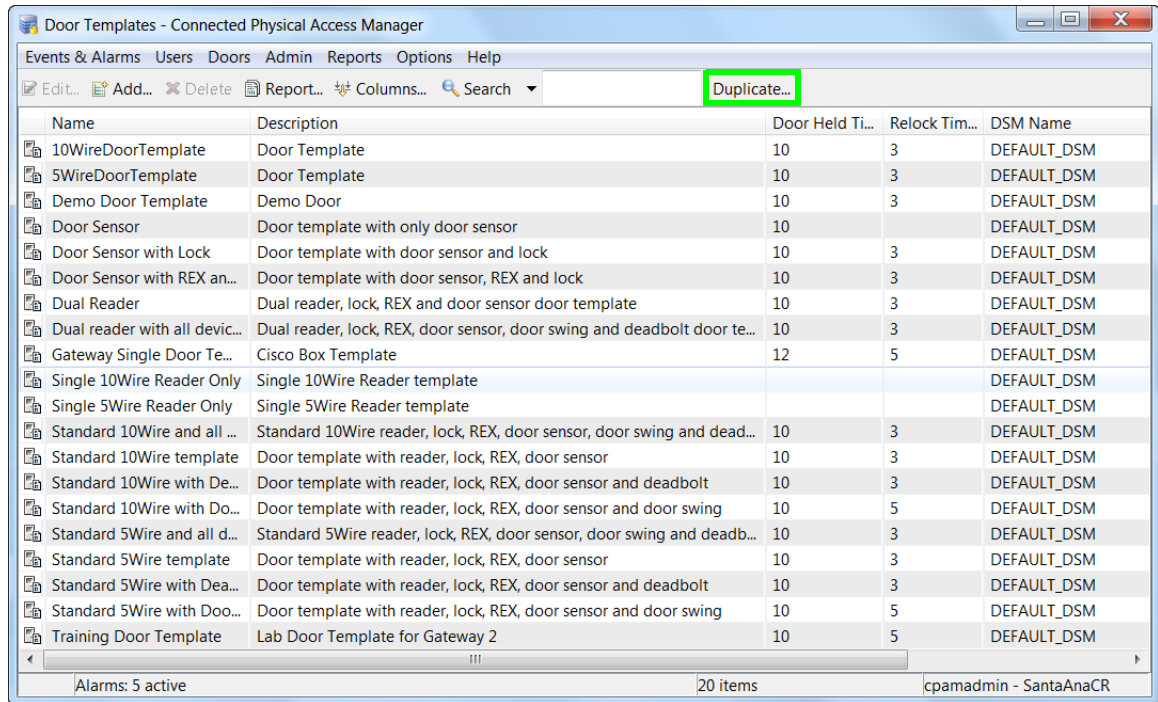

- Step 4** In the resulting dialog, type the **New name** for the template and click **OK**, as shown in [Figure 8-6](#).

Figure 8-6 Duplicate Name

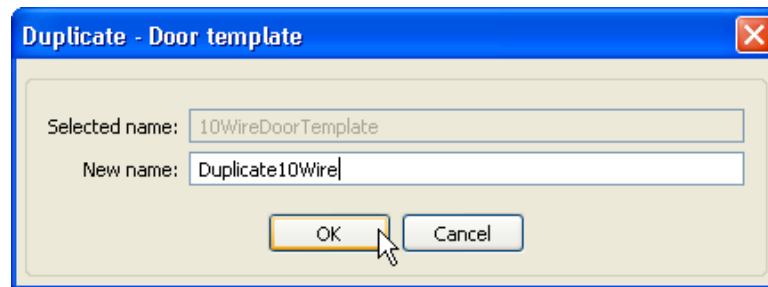

**Step 5** Back in the **Door Templates** window, select the new template, and click the **Edit** button on the toolbar.

**Step 6** Revise the template settings as described in the appropriate configuration section:

- [Configuring Door Templates, page 8-2](#)
- [Configuring Device Templates, page 8-11](#)
- [Configuring Credential Templates, page 8-15](#)

## Duplicating Gateway Templates

- To create a template from a gateway configuration, see [Creating Custom Gateway Configurations without Templates, page 6-2](#).
- To create a clone of a gateway configuration for one-time use, see [Cloning a Gateway Configuration, page 6-53](#). A gateway clone is an independent copy, and is used to configure one other controller.

# Door Configuration Properties

The following properties are configured for a door template and configuration.

See the “[Configuring Door Templates](#)” section on page 8-2 for more information.

*Table 8-1 Door Properties*

Field	Description
<b>Relock interval time (sec)</b>	The number of seconds to keep the door open after an access request is granted (grant access).
<b>Door held open time (sec)</b>	The number of seconds before a DoorHeldOpen alarm is generated.
<b>Door lock on close</b>	<p>The default is <b>Yes</b>. The door will always lock when closed, overriding the <b>Relock interval time</b> (even if a second request was entered while the door was open).</p> <p>Select <b>No</b> to keep the door unlocked for the duration of the <b>Relock interval time</b>, even if it is closed. The relock time is based on the most recent access request for the door.</p>
<b>Deadbolt engage delay (sec)</b>	The amount of time to wait (in seconds) after the door closes to engage the deadbolt.
<b>Scheduled door mode</b>	<p>The schedule set when a door scheduled is applied in <b>Door enable schedule</b>.</p> <p>For example if the Default mode is Lock, and the scheduled door mode is Close, then the door will be locked at all times except during the hours and days defined by the schedule selected in <b>Door enable schedule</b>. See the “<a href="#">Understanding Door Modes, Door Schedules, and the First Unlock Feature</a>” section on page 5-28.</p>
<b>Door enable schedule</b>	<p>The schedule to be used by Door.</p> <p>If you select <b>None</b>, the door will remain in the Default mode at all times and days. If you select a schedule, the schedule overrides the default mode for the times and days defined in the schedule.</p> <p>See <a href="#">Using the Schedule Manager, page 11-9</a> to add or modify the available door schedules. See also the “<a href="#">Understanding Door Modes, Door Schedules, and the First Unlock Feature</a>” section on page 5-28.</p>
<b>First unlock</b>	<p>Activates the door schedule on the first successful badge swipe (during the scheduled time span). If the door is not physically accessed, then the door remains locked. Also known as “Snow day”.</p> <p><b>Note</b> The door remains in default mode until a badge is used to access the door, even after the beginning time for the schedule. This is useful in situations such as snow days to ensure the door is not opened until a badge holder attempts to enter the door.</p> <p>See the “<a href="#">Understanding Door Modes, Door Schedules, and the First Unlock Feature</a>” section on page 5-28, for more information.</p>

Table 8-1 Door Properties

Field	Description
<b>Default mode</b>	<p>The door mode used in non – scheduled times. The door remains in this mode at all times except when a schedule is defined.</p> <ul style="list-style-type: none"> <li>• <i>Open</i>: the door is held open and the lock is in unlocked state.</li> <li>• <i>Close</i>: the door is physically closed and the lock is in unlocked state.</li> <li>• <i>Lock</i>: the door is physically closed and the lock is in Locked state.</li> <li>• <i>Secure</i>: the door is locked and the deadbolt is applied.</li> </ul> <p>See the “<a href="#">Understanding Door Modes, Door Schedules, and the First Unlock Feature</a>” section on page 5-28, for more information.</p>
<b>If badge not in gateway</b>	The action taken by the gateway if the badge is not in the gateway database.
<b>Access decision on timeout</b>	The action taken by the gateway if there is no response within <b>Server access timeout</b> .
<b>If server unreachable (APB)</b>	The action is taken by gateway in case it cannot reach ICPAM. See the “ <a href="#">Using Local (Controller) Credentials if Network Communication is Lost</a> ” section on page 11-24.
<b>Server access timeout (sec)</b>	The number of seconds before an action is taken based on <b>Access decision on timeout</b> .
<b>ADA timespec multiplier</b>	The multiplier used on <b>Relock interval time</b> if an ADA access occurs.
<b>Door swing activation delay (sec)</b>	The number of seconds before the door swing is activated. This setting allows time for the door lock or other devices to activate before the mechanical door swing activates.
<b>Door swing usage</b>	<p>Select one of the following:</p> <ul style="list-style-type: none"> <li>• <b>Always operate</b>: the door swing activates for all access requests.</li> <li>• <b>Operate for ADA only</b>: the door swing operates only for requests from an ADA device.</li> <li>• <b>Do not operate</b>: the door swing does not operate.</li> </ul>
<b>Generic reader</b>	Lists the generic readers associated to the door.
<b>Multifactor authentication timer (sec)</b>	The number of seconds for the multifactor authentication to take place. The default time is 10 seconds.

**Note**

Starting with ICPAM 2.1, the badge that is not in gateway property is set to **Use Server** by default. This enables the badge to be authenticated if the badge is present in ICPAM even if it does not exist in the gateway. This option is only enabled by default for new installations and customers upgrading from previous versions need to change the options in the door properties if desired.

# Device Configuration Properties

This section summarizes the properties that can be configured on door devices.

- [Understanding Normally Open vs. Normally Closed Devices, page 8-30](#)
- [Understanding Supervised vs. Unsupervised Input Devices, page 8-30](#)
- [Device Configuration Properties Summary, page 8-31](#)

## Understanding Normally Open vs. Normally Closed Devices

- Normally open (N.O.) contacts connect the circuit when the relay is activated; the circuit is disconnected when the relay is inactive.
- Normally closed (N.C.) contacts disconnect the circuit when the relay is activated; the circuit is connected when the relay is inactive.

## Understanding Supervised vs. Unsupervised Input Devices

Door input devices can be supervised or unsupervised

- Unsupervised input devices have two states: active or inactive.
- Supervised input devices have four states: active, inactive, short, and open.

Unsupervised inputs have limited functionality. If a wire is cut or shorted between the input module and a normally open device. The server cannot determine the change and the device would remain in inactive state even when the switch is closed.

To make the input device supervised, use two 1K resistors in the circuit ([Figure 8-7](#)).

- In the *inactive* state, the circuit measures 2000 ohms.
- In the *active* state, the circuit measures 1000 ohms.
- In the *short* state the circuit measures 0 ohms
- In the *open* state the circuit measures infinite ohms.

When the input device is supervised, ICPAM can determine if a wire is cut or shorted.

**Figure 8-7** Example of a Supervised Door Sensor

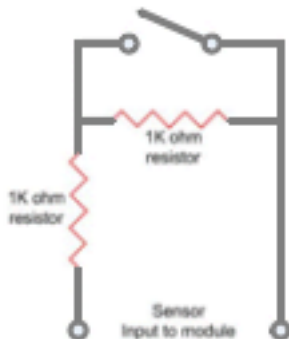

**Example used: Door Sensor**

OHMs	State	Door State	Error Posted?	Input Trusted?
2000	Inactive	Closed	No	Yes
1000	Active	Open	No	Yes
Zero	Short	?????	Yes	No
Infinite	Open	?????	Yes	No

## Device Configuration Properties Summary

Table 8-2 describes device settings for common device types.

*Table 8-2 Device Configuration Properties*

Device	Properties
Deadbolt	<ul style="list-style-type: none"> <li>• <b>Name:</b> The template name.</li> <li>• <b>Model:</b> The device model.</li> <li>• <b>Vendor:</b> The device vendor or manufacturer.</li> <li>• <b>Description:</b> A text description of the device.</li> </ul>
Door Swing	<ul style="list-style-type: none"> <li>• <b>Name:</b> The template name.</li> <li>• <b>Model:</b> The device model.</li> <li>• <b>Vendor:</b> The device vendor or manufacturer.</li> <li>• <b>Description:</b> A text description of the device.</li> <li>• <b>Trigger Time (sec):</b> The number of seconds that power is applied to operate the door swing.</li> </ul>
Door Sensor	<ul style="list-style-type: none"> <li>• <b>Sensor input:</b> The type of device contact: <ul style="list-style-type: none"> <li>– <b>Normally Open:</b> the device is normally open.</li> <li>– <b>Normally Closed:</b> the device is normally closed.</li> </ul> </li> <li>• <b>Supervised:</b> Defines if the device is supervised or unsupervised.</li> <li>• <b>Device state:</b> The default state of the device.</li> </ul>
Duress Sensor	<ul style="list-style-type: none"> <li>• <b>Sensor input:</b> The type of device contact: <ul style="list-style-type: none"> <li>– <b>Normally Open:</b> the device is normally open.</li> <li>– <b>Normally Closed:</b> the device is normally closed.</li> </ul> </li> <li>• <b>Supervised:</b> Defines if the device is supervised or unsupervised.</li> <li>• <b>Sensor state:</b> The default state of the device.</li> </ul>
Fire Sensor	<ul style="list-style-type: none"> <li>• <b>Sensor input:</b> The type of device contact: <ul style="list-style-type: none"> <li>– <b>Normally Open:</b> the device is normally open.</li> <li>– <b>Normally Closed:</b> the device is normally closed.</li> </ul> </li> <li>• <b>Supervised:</b> Defines if the device is supervised or unsupervised.</li> <li>• <b>Device state:</b> The default state of the device.</li> </ul>
Generic Input Device	<ul style="list-style-type: none"> <li>• <b>Normal state:</b> The type of device contact: <ul style="list-style-type: none"> <li>– <b>Normally Open:</b> the device is normally open.</li> <li>– <b>Normally Closed:</b> the device is normally closed.</li> </ul> </li> <li>• <b>Supervised:</b> Defines if the device is supervised or unsupervised.</li> <li>• <b>Device state:</b> The default state of the device.</li> </ul>

Table 8-2 Device Configuration Properties (continued)

Device	Properties
Generic Output Device	<ul style="list-style-type: none"> <li>• <b>Name:</b> The template name.</li> <li>• <b>Model:</b> The device model.</li> <li>• <b>Vendor:</b> The device vendor or manufacturer.</li> <li>• <b>Description:</b> A text description of the device.</li> <li>• <b>Activation Time (ms):</b> When the command <b>Timed Activate Relay</b> is invoked, this property defines the number of milliseconds the generic output is activated.</li> </ul> <p><b>Note</b> Starting with CPAM Release 1.1.0, generic output and lock devices must use the physical wire connections to the gateway or expansion module to define if the device is <i>normally open</i> or <i>normally closed</i>. In CPAM Release 1.0.3 or earlier, this setting could also be made in software. If you are upgrading from CPAM Release 1.0.3 or earlier, verify that devices are correctly wired to the module as <i>normally open</i> or <i>normally closed</i>. See the <i>Cisco Physical Access Gateway User Guide</i> for more information.</p>
Glass-Break	<ul style="list-style-type: none"> <li>• <b>Sensor input:</b> The type of device contact: <ul style="list-style-type: none"> <li>– <b>Normally Open:</b> the device is normally open.</li> <li>– <b>Normally Closed:</b> the device is normally closed.</li> </ul> </li> <li>• <b>Supervised:</b> Defines if the device is supervised or unsupervised.</li> <li>• <b>Sensor state:</b> The default state of the device.</li> </ul>
Lock	<ul style="list-style-type: none"> <li>• <b>Name:</b> The template name.</li> <li>• <b>Model:</b> The device model.</li> <li>• <b>Vendor:</b> The device vendor or manufacturer.</li> <li>• <b>Description:</b> A text description of the device.</li> </ul> <p><b>Note</b> Starting with CPAM Release 1.1.0, generic output and lock devices must use the physical wire connections to the gateway or expansion module to define if the device is <i>normally open</i> or <i>normally closed</i>. In CPAM Release 1.0.3 or earlier, this setting could also be made in software. If you are upgrading from CPAM Release 1.0.3 or earlier, verify that devices are correctly wired to the module as <i>normally open</i> or <i>normally closed</i>. See the <i>Cisco Physical Access Gateway User Guide</i> for more information.</p>
Motion Sensor	<ul style="list-style-type: none"> <li>• <b>Name:</b> The template name.</li> <li>• <b>Model:</b> The device model.</li> <li>• <b>Vendor:</b> The device vendor or manufacturer.</li> <li>• <b>Description:</b> A text description of the device.</li> <li>• <b>Normal state:</b> The type of device contact: <ul style="list-style-type: none"> <li>– <b>Normally Open:</b> the device is normally open.</li> <li>– <b>Normally Closed:</b> the device is normally closed.</li> </ul> </li> <li>• <b>Supervised:</b> Defines if the device is supervised or unsupervised.</li> <li>• <b>Device state:</b> The default state of the device.</li> </ul>



Table 8-2 Device Configuration Properties (continued)

Device	Properties
Power Fail	<ul style="list-style-type: none"> <li>• <b>Normal state:</b> The type of device contact:               <ul style="list-style-type: none"> <li>– <b>Normally Open:</b> the device is normally open.</li> <li>– <b>Normally Closed:</b> the device is normally closed.</li> </ul> </li> <li>• <b>Supervised:</b> Defines if the device is supervised or unsupervised.</li> <li>• <b>Power fail state:</b> The default state of the device.</li> </ul>
REX	<p data-bbox="597 552 1490 646"><b>Note</b> REX is an abbreviation for request to exit. A REX is a type of door hardware, typically a button that allows people to exit through an access point without using a badge or PIN.</p> <ul style="list-style-type: none"> <li>• <b>Rex input:</b> The type of device contact:               <ul style="list-style-type: none"> <li>– <b>Normally Open:</b> the device is normally open.</li> <li>– <b>Normally Closed:</b> the device is normally closed.</li> </ul> </li> <li>• <b>Device state:</b> The default state of the device.</li> <li>• <b>Supervised:</b> Defines if the device is supervised or unsupervised.</li> <li>• <b>Push button:</b> Indicates a push button type of REX.</li> <li>• <b>Push button type:</b> Indicates the kind of push button REX.</li> <li>• <b>ADA enabled:</b> Indicates if ADA is enabled or not. If ADA is enabled, <i>ADA timespec multiplier</i> property is applied on the door when REX is activated.</li> </ul>

Table 8-2 Device Configuration Properties (continued)



Device	Properties
Reader	<ul style="list-style-type: none"> <li>• <b>Reader type:</b> <ul style="list-style-type: none"> <li>– Card Reader</li> <li>– Card and Keypad Reader</li> <li>– Keypad Reader</li> </ul> </li> </ul> <hr/> <p> <b>Note</b> The device does not support a reader device template with the type keypad reader.</p> <hr/> <ul style="list-style-type: none"> <li>• <b>Protocol:</b> Only Wiegand is supported.</li> <li>• <b>Data format:</b> Only Standard Wiegand is supported.</li> <li>• <b>Credential template:</b> Set of credential templates to be used to validate the cards presented to this reader.</li> <li>• <b>Category:</b> Entry or Exit reader.</li> <li>• <b>Reader connector:</b> Type of connector Ten Wire/Five Wire</li> <li>• <b>Use hold pin:</b> Flag specifying if the Hold control line is part of the Reader. Not all readers have or use the Hold control line.</li> <li>• <b>Credential order:</b> If the reader is a <i>Card and Keypad Reader</i> this field specifies the credentials order.</li> </ul> <hr/> <p> <b>Note</b> While configuring the reader type as Card and Keypad, the user should declare a PIN for the badge that will be associated with this template. If not, any PIN entered by the user will grant access to the door associated with the template.</p> <hr/> <ul style="list-style-type: none"> <li>• <b>Maximum timeout (sec):</b> If the reader includes a keypad, this field specifies the maximum time to wait for the user to enter the pins using the keypad.</li> <li>• <b>ADA enabled:</b> Specifies if it is an ADA enabled reader. If ADA is enabled, the <i>ADA timespec multiplier</i> door property is used when a valid card with ADA flag set is presented to the reader.</li> <li>• <b>Number of duress keys:</b> If the reader has a keypad, this field specifies the length of duress key. If the duress key or triggers as configured on the door is “89898”, then the value of this field is 5.</li> <li>• <b>Number of pin keys:</b> If the reader has a keypad, this field specifies the length of the pin to expect.</li> <li>• <b>Keys buffered:</b> Specifies if the pins entered are transferred in one frame (keys buffered) or in individual frames (keys not buffered). This is field is set based what is supported by the reader/keypad.</li> </ul>

Table 8-2 Device Configuration Properties (continued)

Device	Properties
Tamper	<ul style="list-style-type: none"> <li>• <b>Tamper input:</b> The type of device contact: <ul style="list-style-type: none"> <li>– <b>Normally Open:</b> the device is normally open.</li> <li>– <b>Normally Closed:</b> the device is normally closed.</li> </ul> </li> <li>• <b>Supervised:</b> Defines if the device is supervised or unsupervised.</li> <li>• <b>Tamper state:</b> The default state of the device.</li> </ul>

## Debounce Timer

Input devices like a door sensor can generate multiple spurious events (such as *Door Forced Open* events) within a short span of time under the following conditions:

- If the sensors are too sensitive to small movements of the door but the door does not open.
- Have faulty wiring.
- Are incorrectly installed.
- Are subject to vibrations.

To prevent spurious events, a debounce timer can be used to mask events within a specified time interval. When the debounce timer is applied, a transition event is considered valid only if it does not change for at least debounce timer interval.



### Note

The debounce timer applies only to events generated by input devices (sensors), such as INPUT\_LOW/INPUT\_HIGH. These events are not propagated to the ICPAM server, so there is no way of validating the debounce timer using Events Monitoring from the ICPAM server. Debounce timer validations can only be performed using the debugging logs on the controller for the sensor. For example, see the `bp_msg` log.

The debounce timer is disabled by default (the default timer is zero seconds, meaning there is no event suppression). To enable the timer, configure each input interface with a maximum value of 500 milliseconds.

To determine the correct timer value, observe the events to ensure that valid events are not being suppressed. Valid events can be missed if the debounce timer value is too high. If valid events are suppressed, reduce the timer value.



### Note

The debounce timer currently does not support Tamper and Powerfail devices.

### Procedure

To configure the debounce timer, do the following:

#### Step 1

Create a new input device template.

- a. Select **Doors > Templates > Device Templates**.
- b. In the **Device Templates** window, click the **Add...** button on the toolbar.

The **Create New Device Template** wizard appears, like in this example:

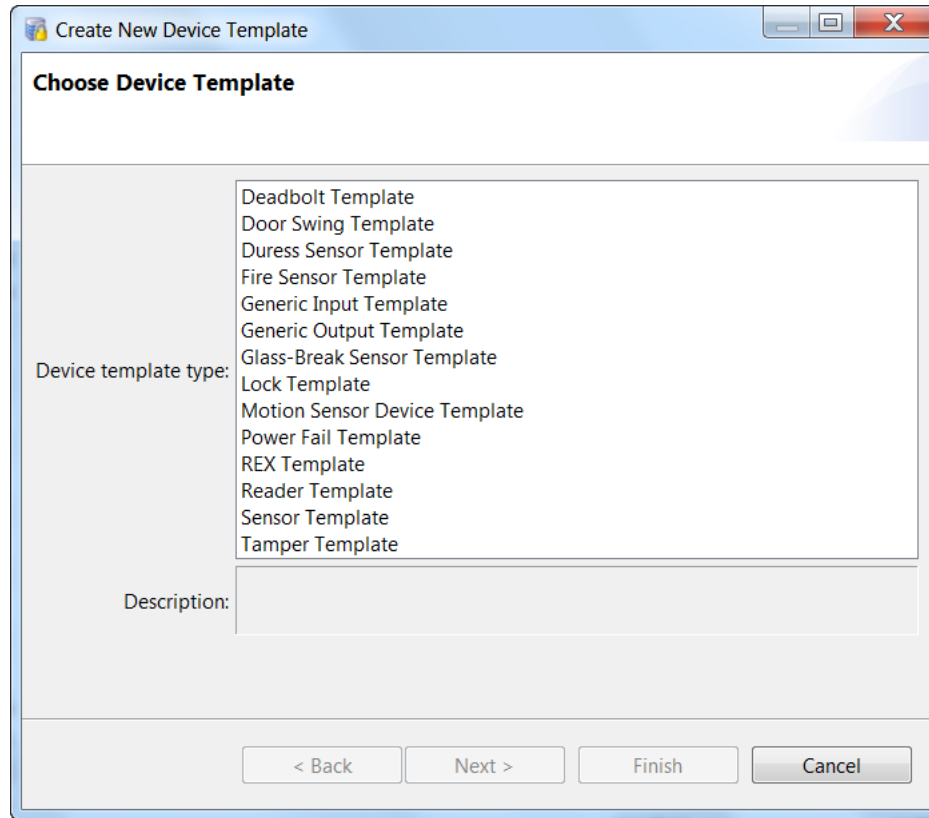

- c. Click to highlight a door sensor or a duress sensor.
- d. Click **Next**. A screen with the debounce timer field on it.
- e. Specify the debounce timer value in the **Debounce Timer (ms)** field.

**Step 2** Create a new input device for the gateway.

- a. Go to **Doors > Hardware Tree**.
- b. Create a new input device for the gateway.

Figure 8-8 New Generic Input Device command

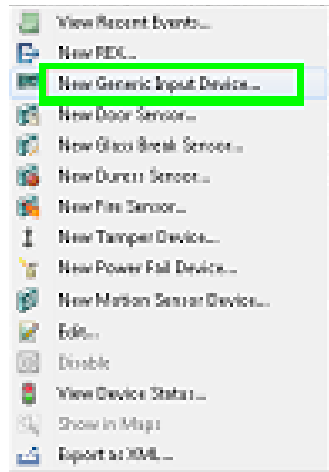

- c. Select the **Properties** tab.
- d. Choose the corresponding device template.
- e. Enter the debounce timer value in the appropriate field.

Figure 8-9 Debounce Timer field (on the Add Door Sensor window)

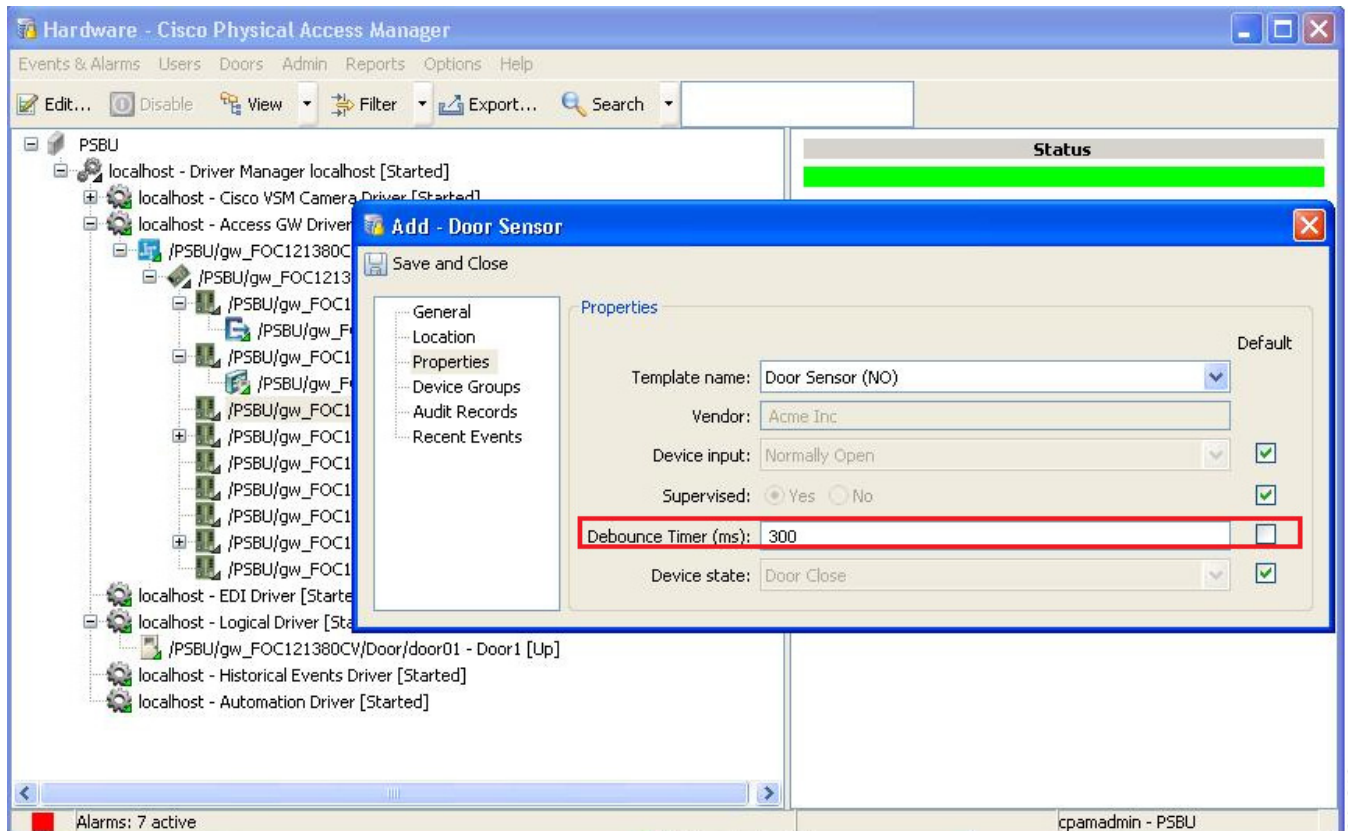

**Tip**

---

If the input device is already associated with the gateway, right-click the interface, select **Edit** and enter the debounce timer value. After setting the debounce timer the configuration must be applied on the associated gateway.

---

**Note**

---

The default value for the Debounce Timer is 0 ms.

---

# Configuring Personnel and Badges

This chapter describes how to create the personnel records and badges used to access doors in the ICPAM system.



Note

For instructions to synchronize ICPAM with personnel records from another database, see [Chapter 14, “System Integration”](#).

## Contents

- [Configuring Personnel, page 9-2](#)
- [Downloading Credential Changes to the Controllers, page 9-9](#)
- [Viewing Audit Records and Events for Personnel Records, page 9-10](#)
- [Editing Organization and Department Lists, page 9-12](#)
- [Importing Personnel Records Using a Comma Separated Value \(CSV\) File, page 9-14](#)
- [Using a SnapShell License Scanner to Create Personnel Records, page 9-19](#)
  - [Install and Configure the SnapShell Scanner, page 9-19](#)
  - [Scan a License to Create a New Personnel Record, page 9-23](#)
- [Configuring Badges, page 9-24](#)
  - [Configuring Badge Templates, page 9-25](#)
  - [Badge Properties, page 9-26](#)
  - [Badge Authentication, page 9-36](#)
  - [Printing Badges, page 9-48](#)
- [Setting Up Image and Signature Options for Personnel Records, page 9-59](#)

# Configuring Personnel

Use the **Personnel** module to manage personnel records. Personnel records contain information on the site's personnel, such as employees, contractors, and visitors. A personnel record may have associated credentials, such as badges, PINs, or logins.



## Tip

Personnel records are unique based on the Personnel ID of the record. If a record is imported with the same ID number, then the current record is updated with the new data.

This section describes how to manage personnel, including adding an image, a badge, and an associated access policies.

**Step 1** Select **Personnel** from the Users menu.

*Figure 9-1 Personnel module's main window*

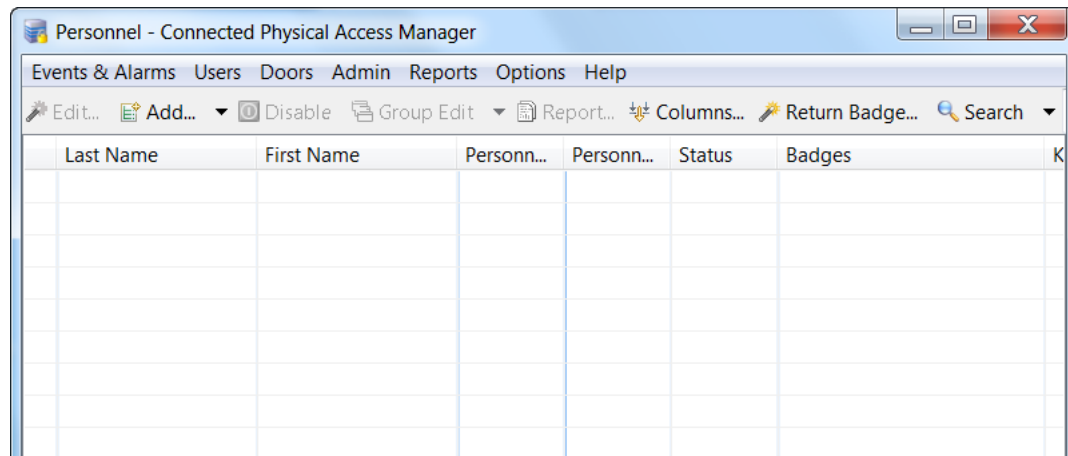

**Step 2** To add a personnel record, choose **Add (Advanced)...**

- To modify an existing record, select the entry and click **Edit**.
- To edit all records displayed in the list, click **Group Edit...** See [Using Group Edit, page 3-14](#) for more information.
- To disable a record, select the entry and choose **Disable**. This is equivalent to setting the **Status** to **Inactive**.



## Tip

You can also scan a drivers license to create a new record with information on the card. See the [“Using a SnapShell License Scanner to Create Personnel Records”](#) section on page 9-19.

**Step 3** Specify the information on the **General** page, as shown in [Figure 9-2](#). See [Table 9-1](#) for field descriptions. The first name, last name, and SSN/FIN/ID fields are required.



Figure 9-2 General page of the Add Personnel Record window

Table 9-1 Fields on the Personnel module's General page

Field	Description
<b>Title</b>	(Optional) The person's formal title. Select a value from the drop-down menu (such as <b>Dr.</b> , <b>Mr.</b> , or <b>Ms.</b> ) or enter the text manually.
<b>First name</b>	(Required) The person's given name.
<b>Middle name</b>	(Optional) The person's middle name.
<b>Last name</b>	(Required) The person's surname (family name).
<b>Suffix</b>	(Optional) The suffix at the end of the person's name. Select a value from the drop-down menu (such as <b>I</b> , <b>II</b> , <b>III</b> , <b>Jr.</b> , and <b>Sr.</b> ) or enter the text manually.
<b>Date of birth</b>	(Optional) The person's birth date.
<b>SSN/ID#/FIN</b>	(Required) Select the type of ID number used from the drop-down menu, and enter the actual number in the field to the right.  <b>Note</b> Personnel records are unique based on the ID number of the record. If a record is imported with the same ID number, then the current record is updated with the new data.
<b>Comments</b>	(Optional) Any additional comments or notes about the personnel record.
<b>Site</b>	(Optional) The site associated with the personnel record.
<b>Import...</b>	(Optional) Click <b>Import...</b> to add an image to the record (select a JPEG image from a local drive and click <b>OK</b> ).

**Step 4** (Optional) Add an image to the personnel record:

- a. Click the **Capture...** button to open an image capture device interface.
  - If a picture has already been taken, click the **Import...** button and browse to the desired JPEG image for the person's picture and click the **OK** button and skip to step 8.

- If the **Capture...** button is grayed out, enable the capture device in the properties section (see [Enabling Image Capture Devices, page 9-59](#)).

Use the built-in tools to pan, tilt, and zoom to the appropriate location. Once satisfied with the camera settings, click the **Capture** button to take a picture. After clicking the **Capture** button, a preview of the picture will be displayed.

In case a non-TWAIN device (like a webcam) is used, click the “capture image” button to take a snapshot of the feed from the webcam. The wizard allows the user to select a maximum of 4 captures from a feed (numbered 1-4).

Double-click the appropriate image from the captured images to proceed to the next step. Using the mouse, move the highlighted box to the appropriate location. The area within the highlighted box will be saved within the personnel record.

- Click the **Save** button to save the picture, or click the **Capture** button again to take another picture. Once the **Save** button is selected, the **Capture Image** wizard will open. Using the mouse, move the highlighted box to the appropriate location. The area within the highlighted box will be saved within the personnel record.
- Click **Next** to preview the finalized image. Click the **Finish** button to close the wizard and preview the image within the new personnel record.

**Step 5** (Optional) Add a signature to the personnel record. See [Enabling Signature Capture Devices, page 9-61](#), for more information.

**Step 6** Specify the **Occupational** information for the personnel record, as shown in [Figure 9-3](#). See [Table 9-2](#) for field descriptions.

**Figure 9-3** Occupational page of the Add Personnel Record window

**Table 9-2** Fields on the Personnel module's Occupational page

Field	Description
<b>Title in organization</b>	The person's title within the organization. For example, Director of Engineering.
<b>Employee number</b>	The employee number, if applicable. Generally, but not required to be, unique.

Table 9-2 Fields on the Personnel module's Occupational page (continued)

Field	Description
<b>Personnel Type</b>	The type of employee. Options include the following: <ul style="list-style-type: none"> <li>• <b>Contractor</b></li> <li>• <b>Employee - Full Time</b></li> <li>• <b>Employee - Part Time</b></li> <li>• <b>Other</b></li> <li>• <b>Visitor</b></li> </ul>
<b>Status</b>	The status of the employee. Options include the following: <ul style="list-style-type: none"> <li>• <b>Active</b></li> <li>• <b>Inactive</b></li> <li>• <b>On Leave</b></li> <li>• <b>Retired</b></li> <li>• <b>Terminated</b></li> </ul>
<b>Organization</b>	The organization name to which the person belongs. Select a pre-defined value from the drop-down menu, or type a name in the field. To edit the pre-defined options, see <a href="#">Editing Organization and Department Lists, page 9-12</a> .
<b>Department</b>	The department name within the organization to which the person belongs. Select a pre-defined department name from the drop-down menu, or enter a name in the field. To edit the pre-defined options, see <a href="#">Editing Organization and Department Lists, page 9-12</a> .
<b>Date of hire</b>	The date the employee was hired.

**Step 7** Specify the **Contact** information for the personnel record, as shown in [Figure 9-4](#). See [Table 9-3](#) for field descriptions.

Figure 9-4 Contact page of the Add Personnel Record window

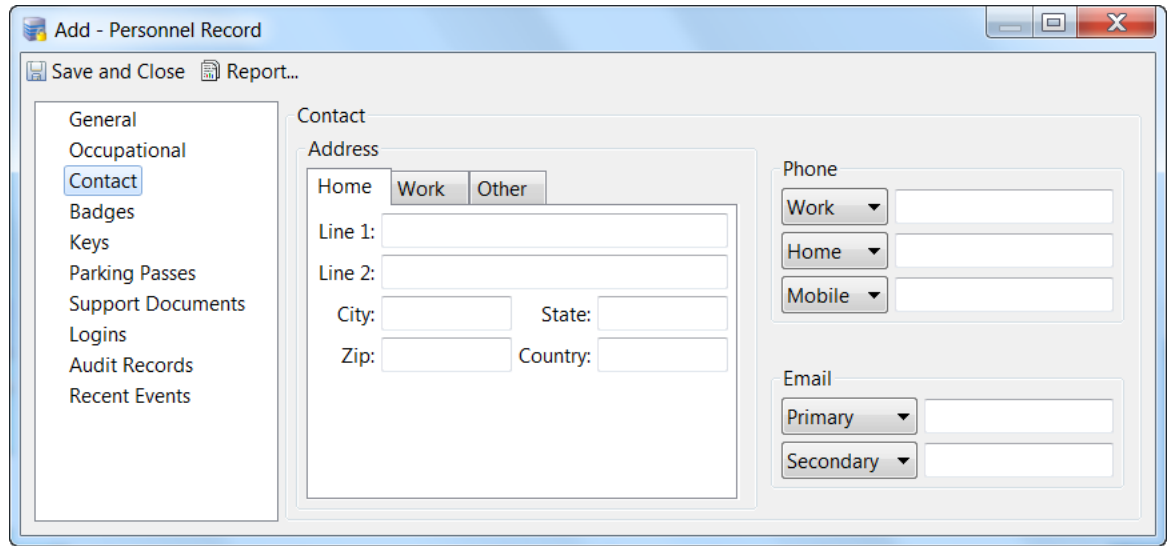
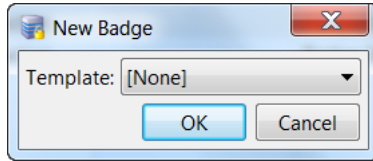

Table 9-3 Fields on the Personnel module's Contact page

Field	Description
	<ul style="list-style-type: none"> <li>• Work</li> <li>• Home</li> <li>• Other</li> </ul>
	<ul style="list-style-type: none"> <li>• Work</li> <li>• Home</li> <li>• Mobile</li> <li>• Fax</li> <li>• Other</li> </ul>
	<ul style="list-style-type: none"> <li>• Primary</li> <li>• Secondary</li> <li>• Other</li> </ul>

- Step 8** Add a badge to the personnel record.
- a. Click the **Badges** tab.
  - b. Click the **Add...** button to open the New Badge dialog.

- c. Select a badge template from the drop-down list, and click **OK**.



To configure a badge without using a template, select **None**.

See [Configuring Badge Templates, page 9-25](#) to create or modify the templates.

- d. Enter the **Card #** and **PIN** (required) in the badge properties window, as shown in [Figure 9-5](#).
- e. Modify the other badge fields, if necessary, as described in [Badge Properties, page 9-26](#).
- f. Click **Save and Close** to save the badge settings.
- g. (Optional) Activate the changes. Changes to credentials (badges) are downloaded to the controllers on a regular schedule. To activate the changes before the next scheduled download, do one of the following.
  - To immediately download the changes to the doors, select **Hardware Tree** from the **Doors** menu, right-click on the **Access GW Driver**, and select **Apply Credential Changes**. This activates the changes on all doors. The badge is ready for use.
  - To change the interval that credential changes are automatically downloaded to the doors, select **System Configuration** from the Admin menu, and then select **ICPAM Settings**. In the field **Credential download frequency (mins)**, enter the number of minutes between downloads. To activate changes to the ICPAM Settings, you must restart the ICPAM appliance. See [Advanced page of the System Configuration window, page 17-37](#) for more information.

*Figure 9-5 Badges page of the Add Personnel Record window*

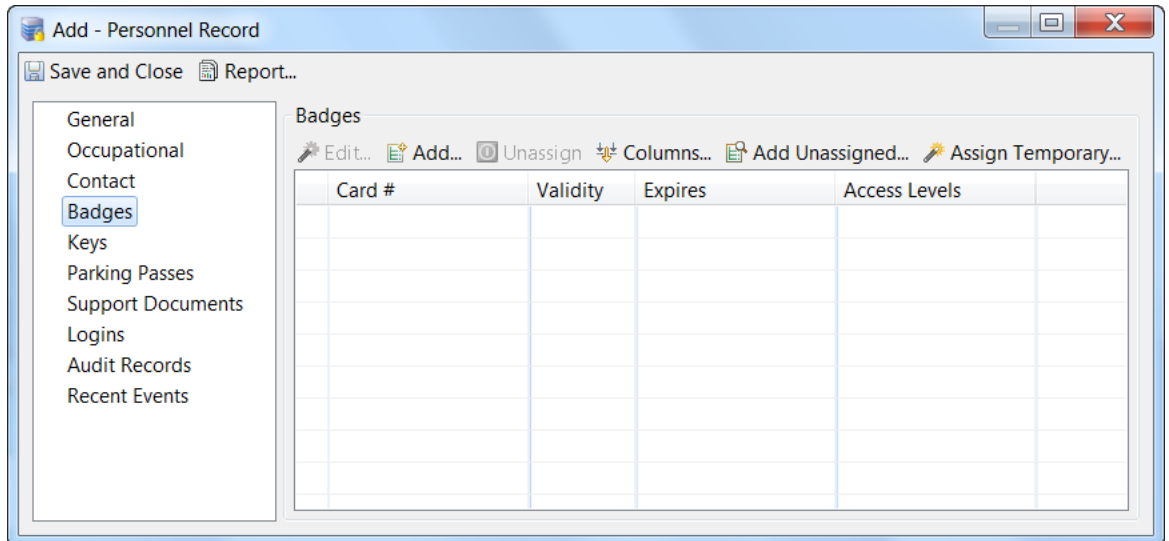

- Step 9** Click the **Logins** tab to edit the logins and profiles assigned to the person. Multiple login usernames can be associated with a personnel record.
- a. From the main window for the Personnel record, click the **Logins** tab.
  - b. Click the **Add...** or **Edit...** button to open the **Logins** window, as shown in [Figure 9-6](#).

Figure 9-6 Logins page of the Add Personnel Record window

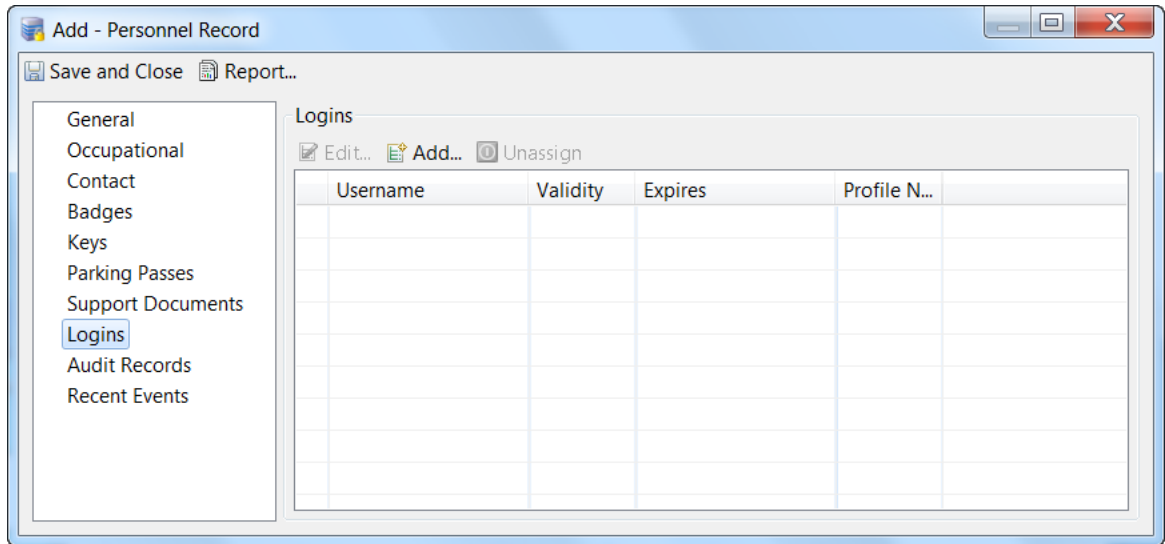

- c. Complete the General settings. For field descriptions, see [Creating User Login Accounts and Assigning Profiles, page 4-9](#).
- d. Complete the Profiles fields to define the access privileges for the login. For field descriptions, see [Creating User Login Accounts and Assigning Profiles, page 4-9](#).
- e. Click **Save and Close**.

**Step 10** If required, you can also specify these attributes:

- To designate one or more keys assigned to this employee, click the **Keys** tab and specify keys issued to this person.
- To specify one or more parking passes for the employee, click the **Parking Passes** tab and specify parking passes for this person.
- To include support documents required for this person, click the **Support Documents** tab and indicate those documents.

**Step 11** When finished, click **Save and Close** in the **Personnel Record** window to make the changes permanent.

# Downloading Credential Changes to the Controllers

By default, any changes to user credentials are automatically downloaded (applied) to the controllers every 60 minutes. If credential changes need to be downloaded sooner, use the **Apply Credential Changes** command on the gateway driver. This command is useful if you want the changes to be immediately applied. For example, to immediately grant or deny user access to a door.

## Procedure

---

- Step 1** Select **Hardware Tree** from the Doors menu.
- Step 2** View the **Credential Download Status**.
- a. Select the **Access GW Driver**.
  - b. Click the **Credential Download Status** tab in the Extended Status field.
  - c. Click the box next to the controller name to show or hide additional information, including the following:
    - **Gateway Name:** the name of the controller.
    - **Status:** the status of the download. For example: `In Progress` OR `Success`.
    - **Time Stamp:** The time of the status change. For example, the time the download changed to `In Progress` OR `Success`.
- Step 3** (Optional) To immediately download any outstanding credential changes for all controllers, right-click the **Access GW Driver**, and select the **Apply Credential Changes** command.
- Otherwise, credential changes are automatically applied to all controllers every 60 minutes.



### Tip

To reapply the complete credential configuration for a specific controller, right-click the controller icon and select the **Download All Credentials** command. This command ensure the data is correct and should be used only if a problem exists

---

# Viewing Audit Records and Events for Personnel Records

This section describes how to view a list of audit records and events for personnel records.

Audit records are generated when a record is added, deleted, or modified, and display information about the change. Events are records of actions, such as attempts to gain access to an access point.

This section includes the following information:

- [Viewing Audit Records, page 9-10](#)
- [Viewing Recent Events, page 9-11](#)

## Viewing Audit Records

- Step 1** Select **Personnel** from the **User** menu.
- Step 2** Double-click an entry (or select the entry and click **Edit**).
- Step 3** Select **Audit Records**.
- Step 4** Double-click an entry to view details for the item. [Figure 9-7](#) describes the audit record fields.

*Figure 9-7 Personnel module's View - Audit Records window*

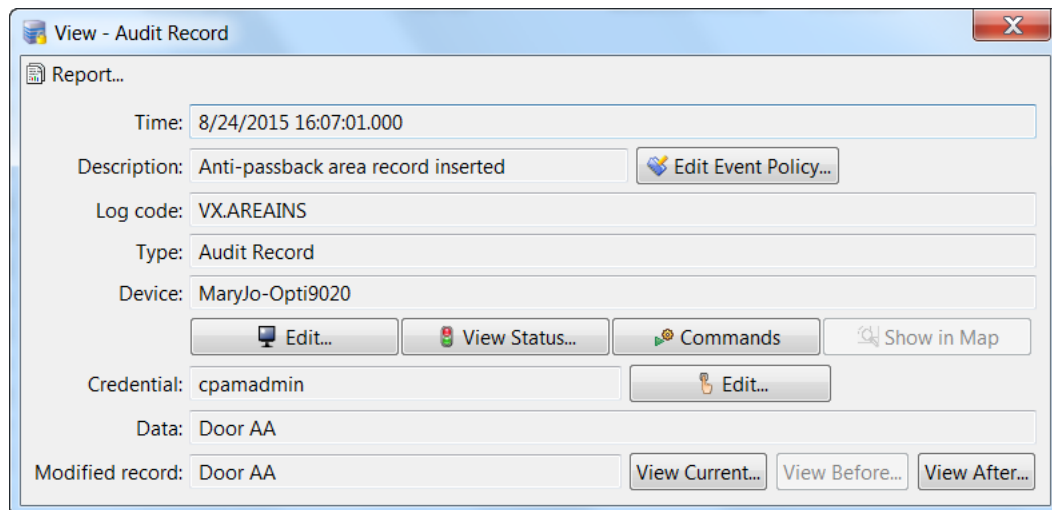

*Table 9-4 Fields on the View - Audit Record window*

Field	Description
<b>Time</b>	The time and date when the modification occurred.
<b>Type</b>	The type of change.
<b>Description</b>	A description of the change.
<b>Device</b>	The workstation name where the modification occurred. Click <b>View</b> to display details for the device where the change was made, including the IP address of the workstation device.



Table 9-4 Fields on the View - Audit Record window (continued)

Field	Description
<b>Credential</b>	The username used when the modification occurred. Click <b>View</b> to display and revise details for the username.
<b>Data</b>	Additional information about the modification.
<b>View Current...</b>	Opens a new window displaying the current settings.
<b>View Before...</b>	Opens a new window displaying the settings before the change was made.
<b>View After...</b>	Opens a new window displaying the settings after the change was made.

## Viewing Recent Events

- Step 1** Select **Personnel** from the **User** menu.
- Step 2** Double-click an entry (or select the entry and click **Edit**).
- Step 3** Select **Recent Events**.
- Step 4** Double-click an entry to view details for the item. Table 9-5 describes the fields. Use the **View**, **Report**, and **Filter** buttons for increased functionality.

Table 9-5 Fields on the View - Recent Events window

Field	Description
<b>Time</b>	The time and date when the event occurred.
<b>Description</b>	A description of the event.
<b>Device</b>	The device associated with the event.
<b>Address</b>	The address of the device.
<b>Personnel Record</b>	The personnel record associated with the event.
<b>Data</b>	This field displays detailed information about the event, the exact value and meaning of which depends on the type of event. This field is generally for advanced or troubleshooting use. If the event is associated with an attempt to gain access to an access point using a badge that is not in the database, this field contains the card number.
<b>Credential</b>	If the event has an associated credential (such as a badge or login), the identifying information of the credential (such as a card or username) is displayed in this field.
<b>Site</b>	The site where the event occurred.

## Editing Organization and Department Lists

Personnel records include an organization and department for the user (see the Occupational section of Personnel configuration, as described in [Configuring Personnel, page 9-2, Step 6](#)).

To define the organization and department selections, do the following:

- Step 1** Select **Organization** from the Users menu, as shown in [Figure 9-8](#).

*Figure 9-8 Organizations module's main window*

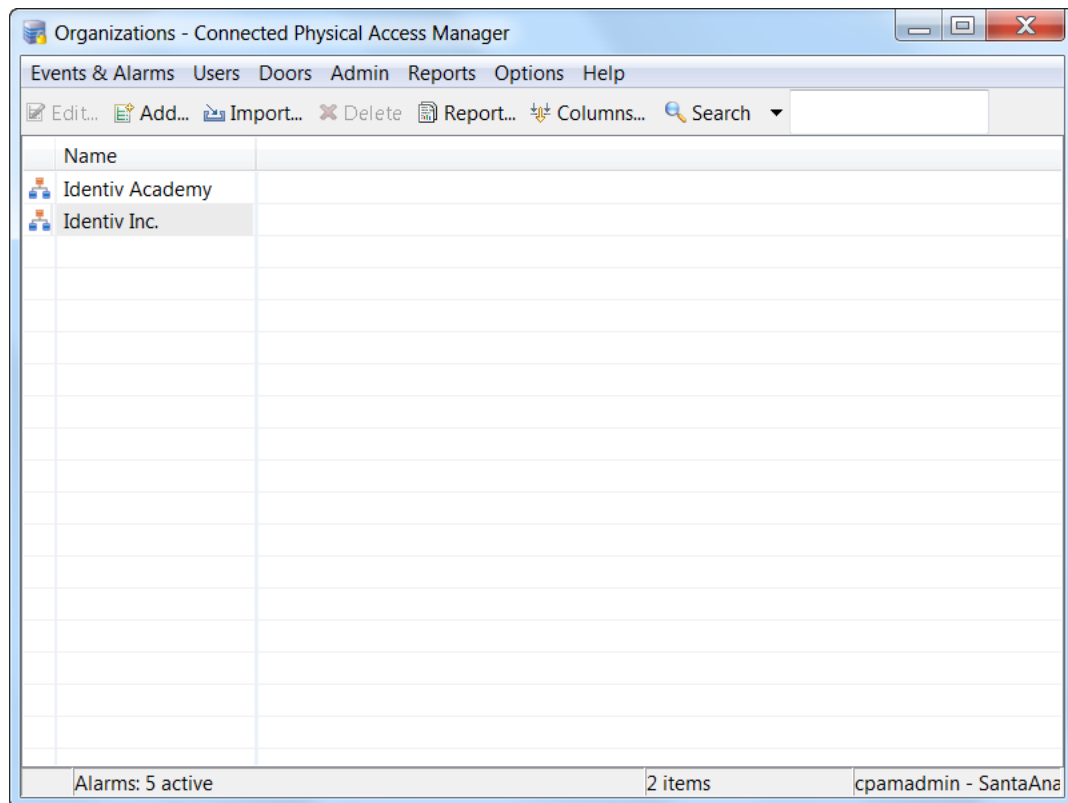

- Step 2** Select one of the following options:
- To add a personnel record, choose **Add...**
  - To modify an existing record, select the entry and click **Edit**. You can also double-click the entry.
  - To delete an entry, select the item and click **Delete**.
- Step 3** If adding or editing an item, the **General** window appears, as shown in [Figure 9-9](#).

**Figure 9-9** General page of the Edit - Organization window

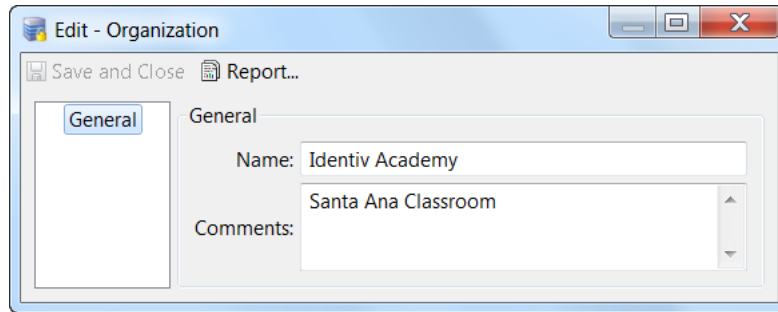

- Step 4** Enter the name of the organization and optional comments to describe the entry.
- Step 5** Click the **Departments** tab to edit the list of departments for the organization (Figure 9-10).

**Figure 9-10** Departments page of the Edit - Organization window

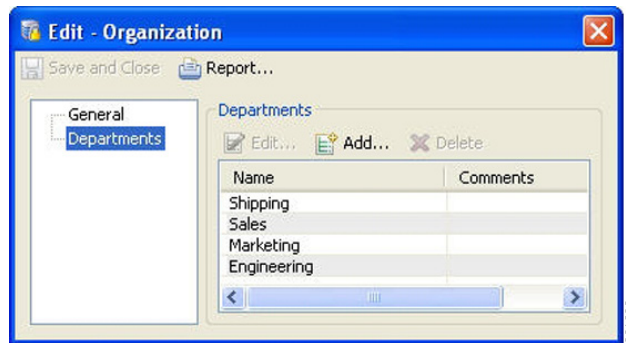

- Step 6** Click **Add** to create a new department entry. To edit an entry, select the item and click **Edit**, or double-click the entry. To delete an item, select the item and click **Delete**.
- Step 7** Click **Save and Close** to return to the main window.
- Step 8** Click **Save and Close** again to save the organization and department changes and close the main window.

# Importing Personnel Records Using a Comma Separated Value (CSV) File

Large amounts of personnel records can be added to ICPAM using a comma separated value (CSV) file. A CSV file can be extracted from all common database vendors. This is the recommended method for the initial transfer of records into ICPAM.

## Before You Begin

Review the following notes before creating EDI projects:

- To avoid system delays, do not import more than 5,000 personnel records at a time. If necessary, create multiple import files of less than 5,000 records each, and then import each file.
- Personnel records are unique based on the ID number of the record. If a record is imported with the same ID number, then the current record is overwritten with the new data.
- When organization and department values are included in an imported personnel record, those values must already exist in the ICPAM configuration. Add the Organization values by manually creating them or through a data import. See [Editing Organization and Department Lists, page 9-12](#) for more information.

Once a personnel CSV file is extracted from a database it can be added to ICPAM using the following process:

- 
- Step 1** Enable the CSV personnel import wizard.
- a. Select **System Configuration** in the **Admin** menu.
  - b. Select the **Personnel** tab ([Figure 9-11](#)).

Figure 9-11 Personnel page of the System Configuration window

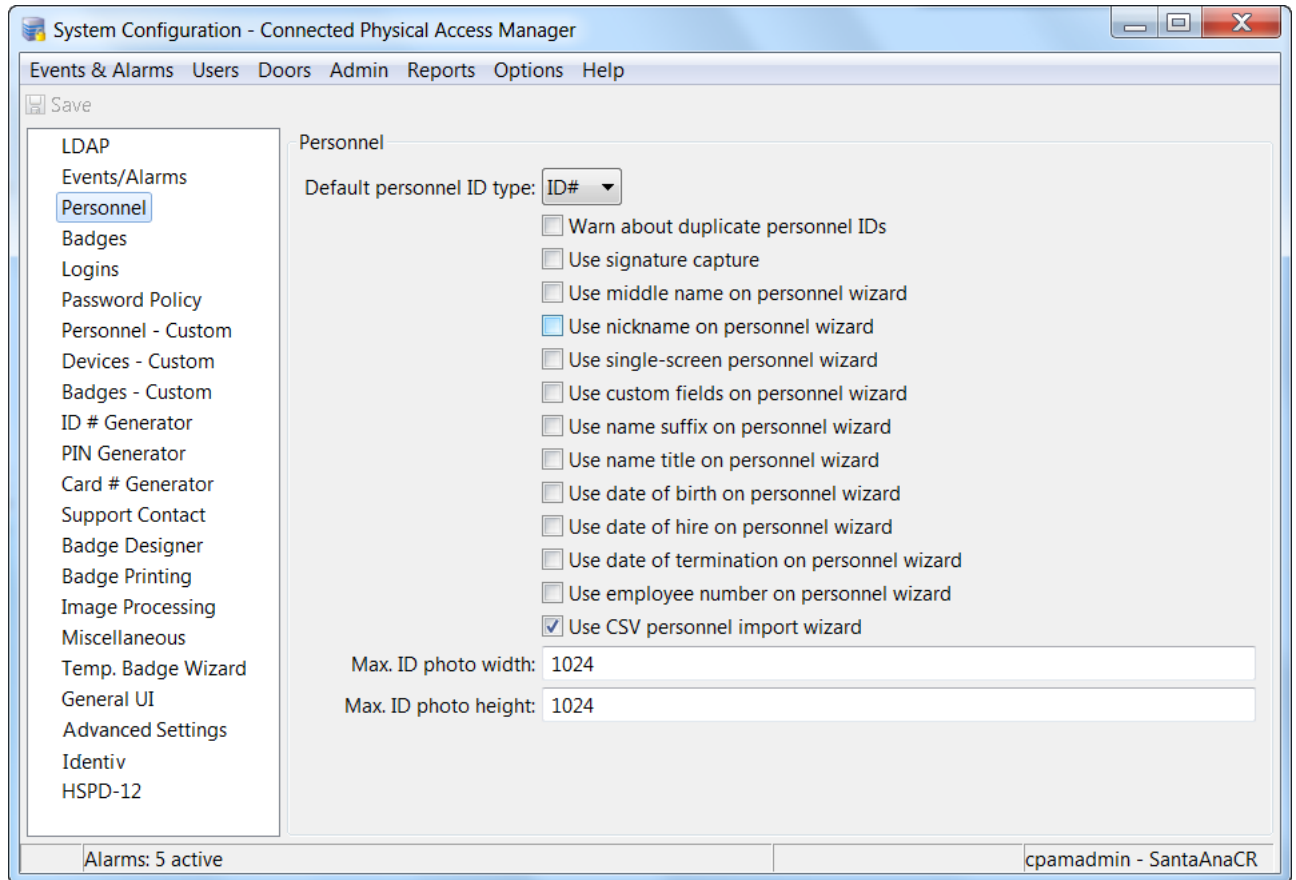

- c. Select the check box for **Use CVS personnel import wizard**.
- d. Click **Save**.
- e. Log out and log back in to the ICPAM application to activate the changes (select Logout from the Options menu).

**Step 2** Select **Personnel** from the User menu.

**Step 3** Select **CSV Import Wizard...** from the **Add...** button's drop-down menu.

**Figure 9-12** File Selection page of the CSV Import wizard

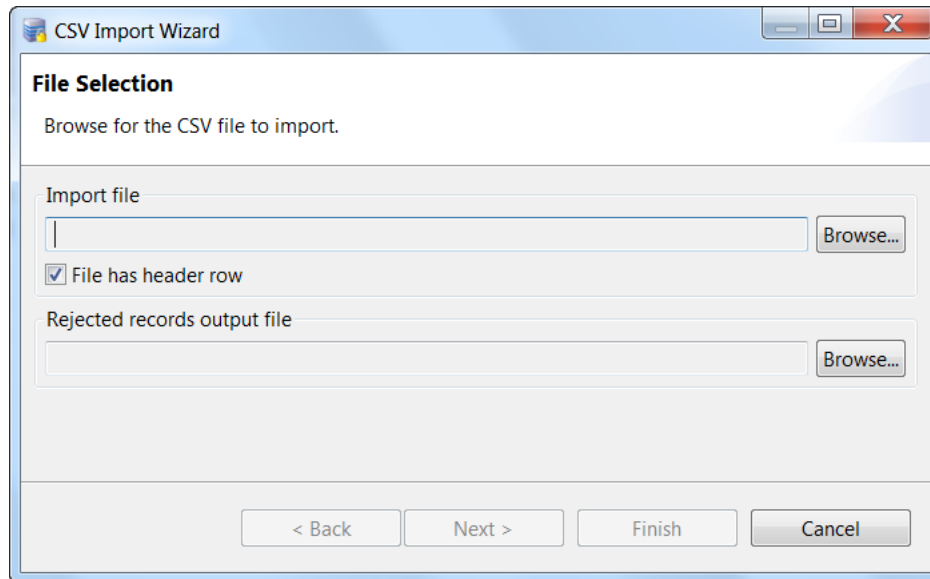

- Step 4** On the File Selection page, select the file to import into ICPAM, as shown in [Figure 9-12](#).
- Click the **Browse...** button and locate the CSV file.
  - If the CVS file includes data for a header row, select the check box for **File has a header row**.
  - Select a file for **Rejected records output file**.
  - Click **Next**.
- Step 5** In the **Column Configuration** window ([Figure 9-13](#)), the top window contains entries from the CSV file with generic column headings such as Column 1, Column 2, etc. The bottom left-hand window displays the currently select column number in the CSV file and the name of the CSV field.

Figure 9-13 Column Configuration page of the CSV Import wizard

Last Name	Column 2	Column 3
Washington	George	1000000
Adams	John	2000000
Jefferson	Thomas	3000000

Column: 1    Import as: [Do Not Import] (Last Name selected)

In header row: Last Name

Buttons: Load Configuration... Save Configuration... < Back Next > Finish Cancel

**Note**

The header row entry will be blank if the **File has header row** check box is not checked in the previous step. The bottom right-hand of the window, labeled **Import as:** contains field names from the ICPAM database.

**Step 6**

Assign an ICPAM field for each CSV field to be imported (Figure 9-13). Personnel records are unique based on the ID number of the record. If a record is imported with the same ID number, then the current record is overwritten with the new data.

- a. Select a CSV column in the top window. By default, Column 1 will be selected, as is shown by the diamond symbol to the left of the column name.
- a. Select the **Import as** field in the lower right-hand window. This defines the ICPAM field that corresponds with the selected CSV field.
- b. Assign all CSV columns to an **Import as** field.
- c. Click **Next**. The **Next** button is not enabled until all CSV fields are assigned.

**Note**

Personnel photos in the .jpg format can be imported. The CSV field assigned to the ICPAM photo field must contain the name of the photo file. In Windows, if a fully-qualified path is not specified in the CSV field (e.g. c:\photos\123456789.jpg) then the location of the photos is assumed to be on the desktop (e.g. C:\Documents and Settings\Desktop\123456789.jpg).

**Step 7** In the Preview window, verify the records and fields before importing, as shown in [Figure 9-14](#).

*Figure 9-14 Preview page of the CSV Import wizard*

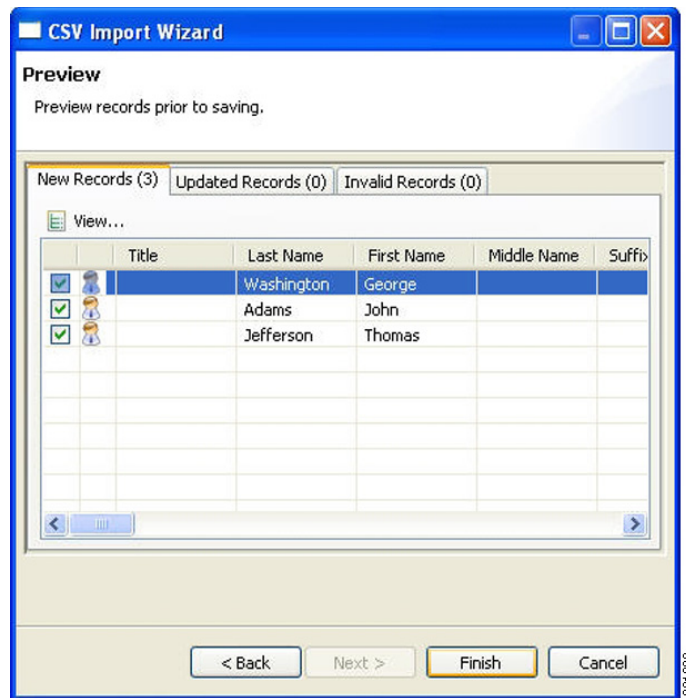

- **New Records** and **Updated Records** tabs: Select or deselect the check box to include or exclude the personnel record from the import.
  - Click **View** to display a preview of the imported personnel record that will be created.
  - Click **Back** to revise the settings if necessary.
- **Invalid Records** tab: displays personnel records that cannot be imported, including the reason for the failure.
  - Click **Export** to save the invalid records to a CSV file so they can be modified and re-imported.
  - The export file is defined in the File Selection screen (see [Step 4](#)). Click **Back** to revise the settings if necessary.

**Step 8** Click **Finish** to complete the import and add the personnel records to the system.



# Using a SnapShell License Scanner to Create Personnel Records

Complete the following instructions to configure and use a SnapShell scanner to scan and import personnel information from a standard driver's license.

- [Install and Configure the SnapShell Scanner, page 9-19](#)
- [Scan a License to Create a New Personnel Record, page 9-23](#)



Note

---

SnapShell scanner is supported only on a PC running Windows XP.

---

## Install and Configure the SnapShell Scanner



Note

---

Do not connect the scanner USB cable to the PC until the scanner installation and configuration is complete.

---

To install and configure the SnapShell scanner software and drivers on a client PC, do the following:

### Procedure

---

- Step 1** Download and install the SnapShell drivers.
- a. Log on to the ICPAM Server Administration utility.
  - b. Select **Downloads**, and then click **SnapShell Driver**.
  - c. Save the `SnapShell-Driver.exe` file to a local drive.
  - d. Double-click the file on your local drive to run the installer.
  - e. Follow the on-screen instructions to complete the installation.  
Click **Run**, **Continue**, **OK**, or **Next** when prompted to accept the default settings and options.
  - f. Restart the client PC.
- Step 2** Download and install the SnapShell SDK software.
- a. Log on to the ICPAM Server Administration utility.
  - b. Select **Downloads**, and then click **Snap Shell SDK**.
  - c. Save the `SnapShell-SDK.exe` file to a local drive.
  - d. Double-click the file on your local drive to run the installer.
  - e. Follow the on-screen instructions until you reach the Destination Location window ([Figure 9-15](#)).
- Step 3** Click **Run**, **Continue**, **OK**, or **Next** when prompted to accept the default settings and options.
- a. In the Destination Location window ([Figure 9-15](#)), record the directory where the software is installed.  
For example: `C:\Program Files\Card Scanning Solutions\SDK`



**Note** The installation directory path is used to update the Windows environmental variables to recognize the new scanner, as described in the following steps.

**Figure 9-15** SnapShell Scanner Destination Location

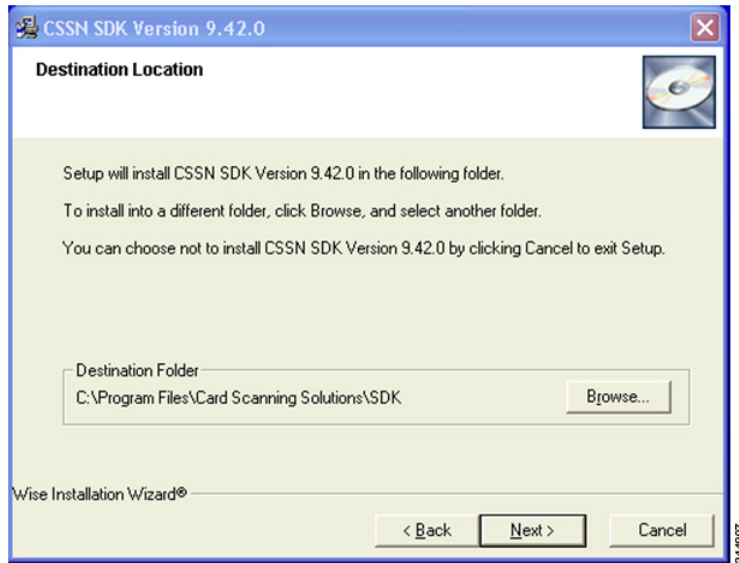

**Note** If you choose a different destination folder, record the new directory path.

- b. Select **Next** or **Install** to accept the remaining default install options and begin the installation process.
- c. Click **Continue**, **Allow** or **OK** for any Windows security warnings.
- d. Wait for the installation process to complete.
- e. Click **Finish**.

**Step 4** Add the scanner destination folder to the Windows environmental variables.

This allows Windows to recognize the scanner. You must have the directory path, as shown in [Figure 9-15](#).

- a. Right click **My Computer**.
- b. Select **Properties**.
- c. Select **Advanced**.
- d. Click the **Environmental Variables** button ([Figure 9-16](#)).

Figure 9-16 Windows Environmental Variables

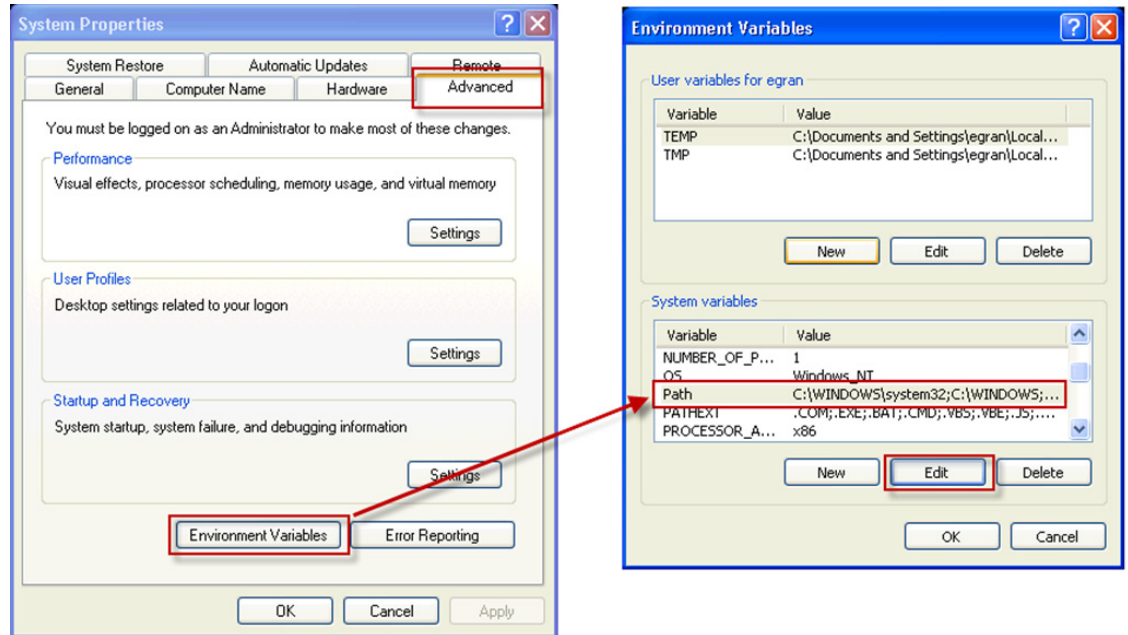

344908

- e. Select **Path** from the System Variables list (Figure 9-16).
  - f. Click **Edit** (Figure 9-16).
- The Edit System Variable dialog appears (Figure 9-17).

Figure 9-17 Edit System Variable dialog

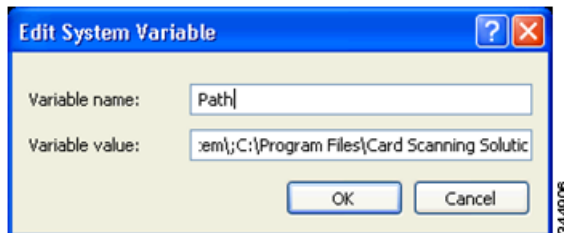

344908

- g. Use the right arrow button on your keyboard to move the cursor to the end of the existing text that appears in the Variable Value field.
- h. Enter a semi-colon (;).
- i. Paste or type the full directory path after the semi-colon (;).

For example:

```
;C:\Program Files\Card Scanning Solutions\SDK
```



**Note** Include the full directory path, including \SDK.

- j. Click **OK** repeatedly to close the Windows Properties windows.

**Step 5** Connect the scanner USB cable to a PC USB port.

- Step 6** Enable the scanner in the ICPAM System Configuration.
- a. Launch the ICPAM desktop client.  
See the “[Logging into the ICPAM Client](#)” section on page 3-3.
  - b. Select **Preferences** from the **Options** menu.
  - c. Select **Personnel Info Scanner** (Figure 9-18).

**Figure 9-18** Preferences for the Personnel Info Scanner

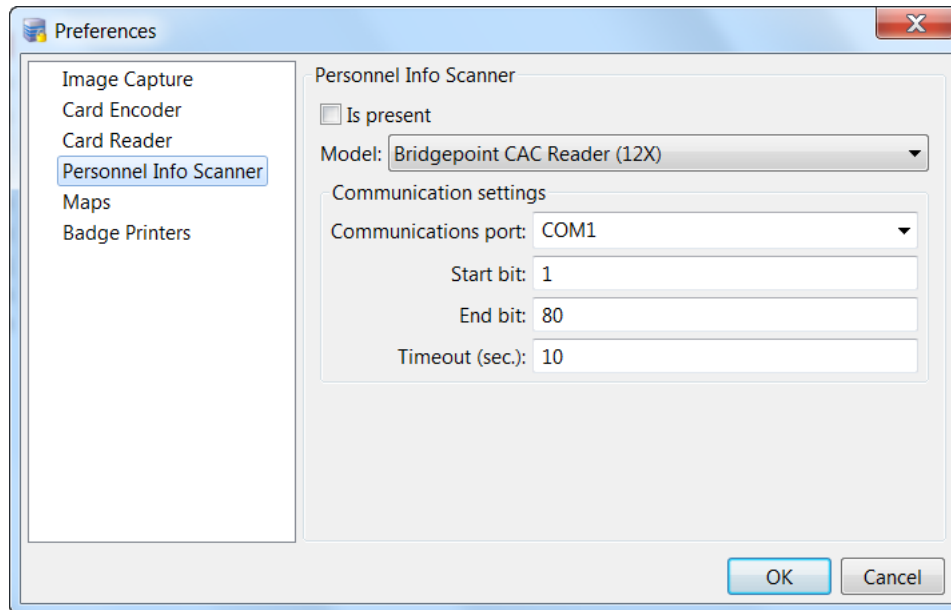

- d. Select **SnapShell Drivers License Reader** from the drop-down menu.
- e. Select **Is present**.  
This indicates that the scanner is connected to the client PC.
- f. Select an option for **Store License in**.
  - Select **ID#** to record the license number in the personnel record ID field.
  - Select **Do not store** if the license number should not be recorded.



**Note** If the license number is not recorded, you must manually enter a value in the new personnel record **ID#** field. This field is required.

- g. Click **OK** to save the changes and close the window.
- h. Log out and log back in to the ICPAM application to activate the changes (select Logout from the Options menu).

## Scan a License to Create a New Personnel Record

Complete the following procedure to create a new personnel record by scanning drivers license.

### Procedure

- Step 1** Install and configure the personnel scanner, as described in the [“Install and Configure the SnapShell Scanner”](#) section on page 9-19.
- Step 2** Log on to the ICPAM desktop client.  
See the [“Logging into the ICPAM Client”](#) section on page 3-3.
- Step 3** Select **Personnel** from the **Users** menu.
- Step 4** Insert the license into the scanner with the information you want to scan flat against the scanner surface.  
See the scanner documentation for more information.
- Step 5** Select **Add** and then **Scan Wizard** (Figure 9-19).

Figure 9-19 Scan Wizard in the Personnel Module

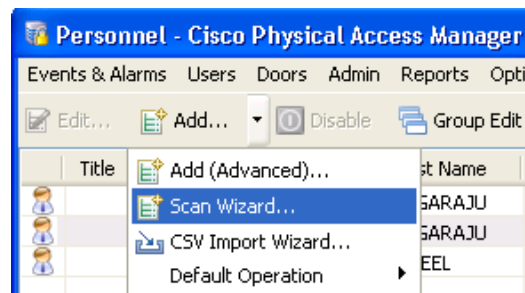

**Note** The Scan Wizard option only appears if the scanner was enabled. See the [“Install and Configure the SnapShell Scanner”](#) section on page 9-19.

- Step 6** Select **Start Scan** (Figure 9-20).

Figure 9-20 Scan Wizard

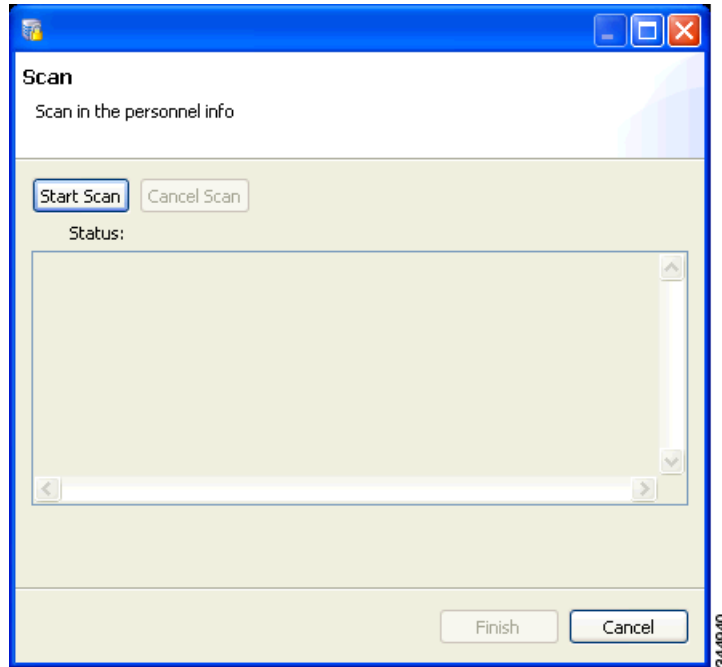

- Step 7** Wait for the scan to complete.
- Step 8** Verify that the personnel record was created and the information from the scanned license is correct.
- Step 9** If the scanner Preferences are set to *not* store the license ID, enter a value in the ID# field (required).
- Step 10** Continue to the [“Configuring Personnel” section on page 9-2](#) to complete the personnel record configuration.

## Configuring Badges

Badges are assigned to personnel records. Use badge templates to define common settings for badge types. In the personnel record, select the badge template to quickly populate the badge fields, and then make additional changes, if necessary.

This section includes the following information.

- [Configuring Badge Templates, page 9-25](#)
- [Badge Properties, page 9-26](#)
- [Badge Authentication, page 9-36](#)
- [Printing Badges, page 9-48](#)



### Tip

Use the **Personnel** module to assign badges. Use the **Badges** module to view a summary of all the badges in the system or to assign unassigned badges. Use the optional **Badge Designer** to create custom designs for your badges.

# Configuring Badge Templates

To configure a badge template:

**Step 1** Select **Badge Templates** from the **User** menu.



**Step 2** Click **Add**, or select an existing template and click **Edit**.

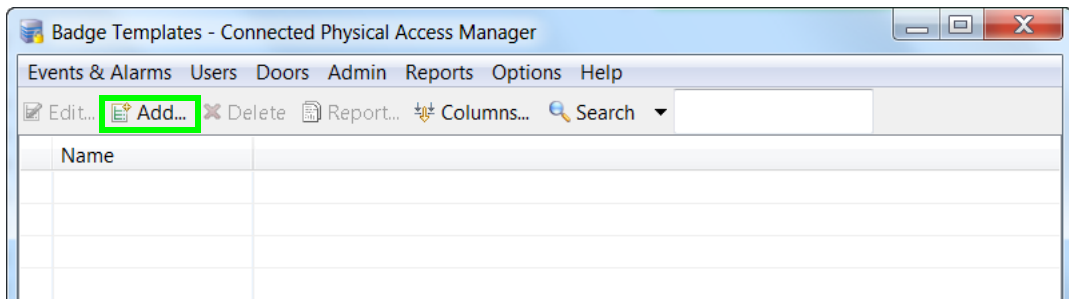

**Step 3** Do one of these:

- If you select **Add**, the **Add - Badge Template** dialog appears:

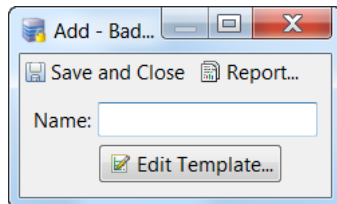

Type the new template **Name**, then click **Edit Template**.

- If you select **Edit**, the **Edit - Badge Template** dialog appears. Click **Edit Template**.

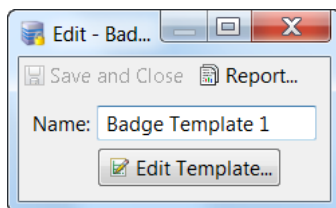

**Step 4** Follow these steps:

- a. Specify the badge properties. See [Badge Properties, page 9-26](#) for field descriptions.

b. Click **OK**.

The screenshot shows a 'Badge Template' dialog box with the following fields and values:

- Facility code: 20
- Badge type: Standard
- Validity: Active
- Watch level: Medium
- Effective: 6/8/2015 Time: 00:00
- Expires: 12/31/2015 Time: 23:59
- Comments: Access to Del's Door

**Note** When a location restricted user reuses a badge template that has an unprivileged access policy associated to it, then the policy is not listed.

**Step 5** Click **Save and Close**. The template is listed in the main window.

## Badge Properties

This section describes the most often-used badge menus and settings. These settings are available in the Personnel, Badge Templates, and Badges windows.

- Use the Personnel module to create and assign badges.
- Use Badge Templates to create pre-configured templates of common settings.
- Use the Badges module to view a summary of all the badges in the system. or to assign unassigned badges.

This section includes the following information:

- [Badges module: General page, page 9-27](#)
- [Badges module: Access Policies page, page 9-30](#)
- [Badges module: Advanced page, page 9-31](#)
- [Badges module: Advanced Gateway page, page 9-32](#)
- [Badges module: Advanced EM-100 page, page 9-33](#)
- [Badges module: HSPD-12 Badge Extension page, page 9-34](#)
- [Badges module: Audit Records page, page 9-35](#)



- Badges module: Recent Events page, page 9-35

## Badges module: General page

The General page as shown in [Figure 9-21](#) includes basic information about the badge.

**Figure 9-21** Badges module: General page

The fields on this page are explained in [Table 9-6](#).

**Table 9-6** Fields on the General page of the Badges module

Field	Description
Card #	(Required) Also known as a badge. A type of credential encoded with a card number, generally on a magnetic stripe or internally like a proximity card, and used to enter access points.  <b>Tip</b> If unsure what the card # is on the card, use the card in the access-control system reader. Open the <b>Events</b> module and view the event with the description <b>Access denied: Card not in database</b> . The <b>Data</b> field of the event displays the card number read from the card. See <a href="#">Viewing Audit Records and Events for Personnel Records, page 9-10</a> .
PIN	(Required) Personal Identification Number. A badge has a PIN associated with it, which, depending on the configuration of an access point, is entered into the keypad on the access point's reader.

Table 9-6 Fields on the General page of the Badges module (continued)

Field	Description
<b>Hot stamp</b>	(Optional) The number physically printed or embossed on a badge. This number is generally independent of the Card Number. Not all badges have a hot stamp number.
<b>Facility code</b>	(Optional) A segment of bits encoded on a card that represent a number for a facility. Often all cards issued for a single facility have the same facility code.
<b>Exempt from Anti-passback</b>	(Optional) If the access point is configured for anti-passback, the badge is exempt from anti-passback enforcement.
<b>Grant One Free APB Pass</b>	(Optional) The badge holder will be anti-passback exempt during the next reader use only.
<b>Badge Type</b>	The type of badge. The options are: <ul style="list-style-type: none"> <li>• <b>Standard</b></li> <li>• <b>Temporary</b></li> <li>• <b>Visitor</b></li> </ul>
<b>Assigned to</b>	(Optional) The personnel record the badge is assigned to.
<b>Validity</b>	(Optional) The current status of the badge. Only the <b>Active</b> option provides access for the badge. The options include: <ul style="list-style-type: none"> <li>• <b>Active:</b> Must be set to this value for access to be granted.</li> <li>• <b>Inactive:</b> Access is denied for all access points in system.</li> <li>• <b>Lost:</b> Access is denied for all access points in system.</li> <li>• <b>Stolen:</b> Access is denied for all access points in system.</li> <li>• <b>Destroyed:</b> Access is denied for all access points in system.</li> </ul> To define new validity types, refer to <a href="#">Credential Validity Types, page 9-29</a> .
<b>Effective</b>	(Optional) The beginning date the badge can be used in the system. If blank, badge access begins immediately. <p><b>Note</b> If a date is entered, the badge can be used at 12.00 AM on the specified day.</p>
<b>Expires</b>	(Optional) The date the badge expires. If blank, the badge never expires. <p><b>Note</b> If a date is entered, the badge expires at 12.00 AM on the specified day.</p>
<b>Site</b>	(Optional) A site is a single instance of a ICPAM database.
<b>Comments</b>	(Optional) Any additional comments or notes about the badge.

## Credential Validity Types

Credential validity types are supplied as options in the drop-down 'Validity' field of the Badges General page ([Badges module: General page, page 9-27](#)) for both Badges and Badge Templates. There are several options that are supplied as default, but the qualified administrator can define more options as the need arises.

To define new types of credential validity:

**Step 1** From the **Admin** menu, select the **Credential Validity Types** option.

The Credential Validity Types window appears:

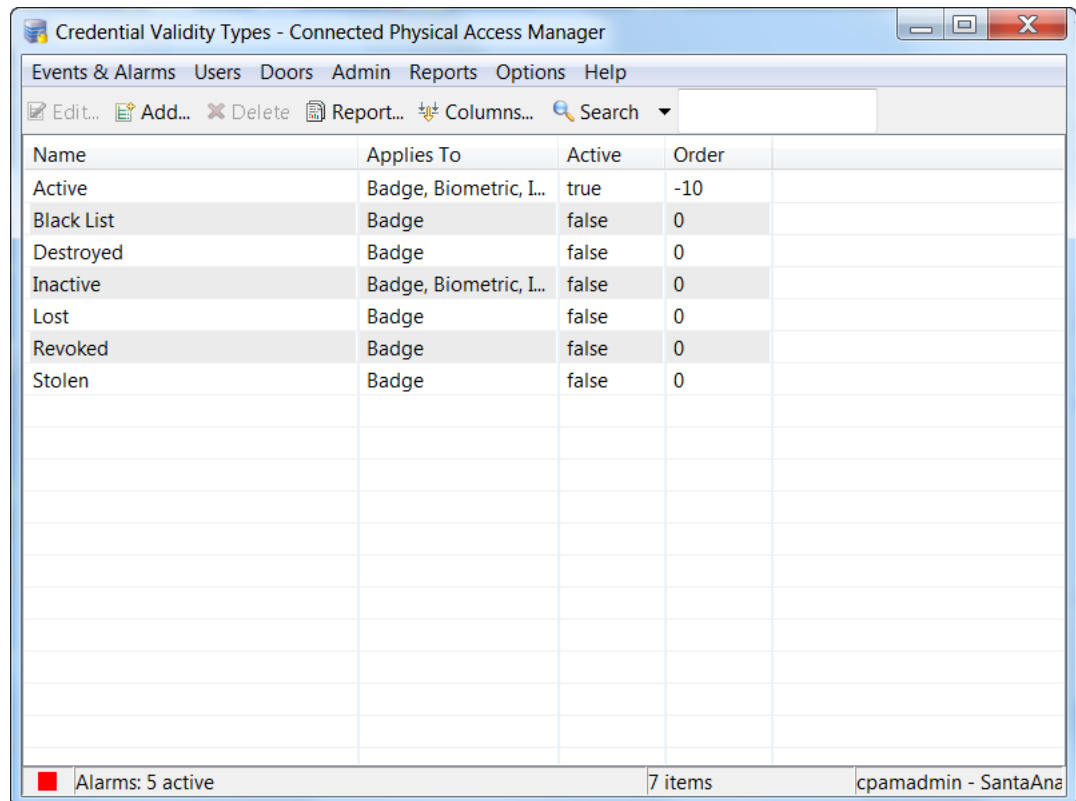

Notice that the default field options appear in this window.

**Step 2** Click **Add...**

The **Add Credential Validity Type** dialog appears.

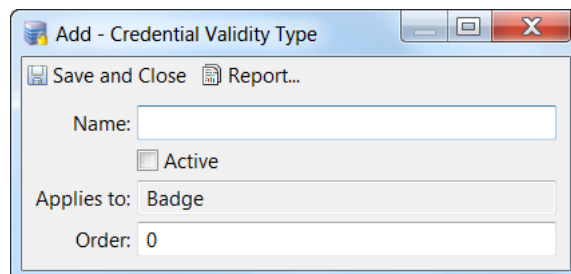

**Step 3** Fill in the form as needed. The fields included on this form include:

<b>Name</b>	Enter the name of this new type
<b>Active</b>	Check this box to indicate that this type is currently active.
<b>Applies to:</b>	Enter the type of item (device) to which this option applies. The default value is <b>Badge</b> .
<b>Order</b>	Enter the order in which this option is presented in the option list.

**Step 4** Click **Save and Close**.

The new credential validity type appears in the credential validity type window.

## Badges module: Access Policies page

Select the door access policies for the user badge. See [Configuring Access Policies, page 11-2](#).

*Figure 9-22 Adding Badges from Personnel Record Option*

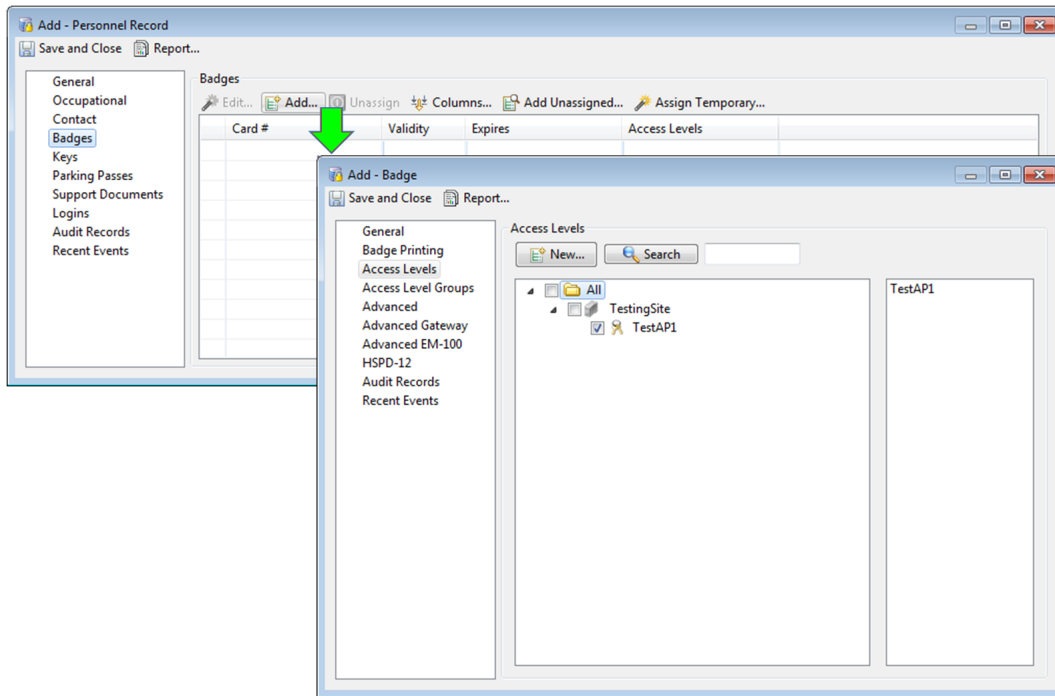

### Note

Starting with the ICPAM 2.1 release, when a user assigns access policies to a badge, both the access policies up to the root of the location hierarchy for the logged-in user and the levels in the location of the user are available for selection. This feature is applicable only if the profile enhancement feature is set in the configuration settings. For more information on this, see [Logins page of the System Configuration window, page 17-11](#).

## Badges module: Advanced page

The Advanced page is shown in [Figure 9-23](#).

**Figure 9-23** Badges module: Advanced page

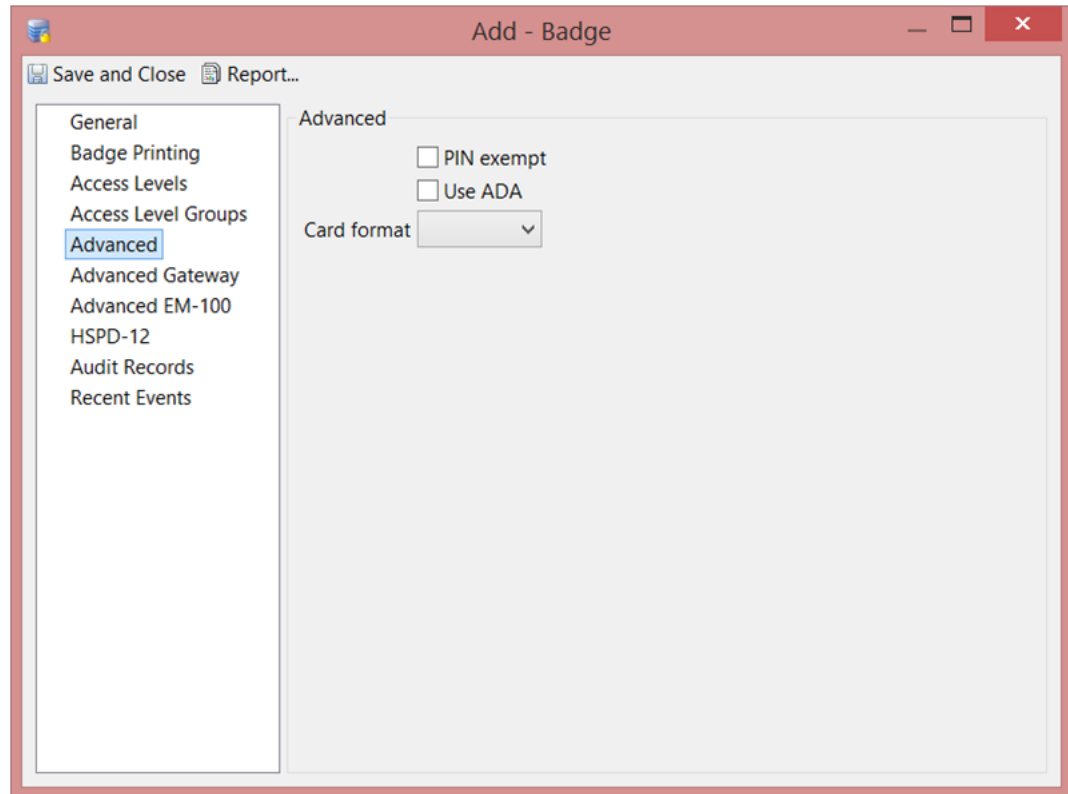

[Table 9-7](#) describes the fields on the Advanced page.

**Table 9-7** Badges Module: Advanced Fields

Field	Description
<b>PIN exempt</b>	Check this box to ensure that the designated badge is exempt from using a PIN for authorization on either the gateway or EM-100 reader.
<b>Use ADA</b>	Check this box to specify that this badge uses ADA specifications for its use at either the gateway or EM-100 reader.
<b>Card format</b>	From the drop-down box, specify the card format this badge can use.  Only those card formats previously defined for this system appear in the list. For more on creating card formats, refer to <a href="#">Configuring Credential Templates</a> .

## Badges module: Advanced Gateway page

The Advanced Gateway page is shown in [Figure 9-24](#).

**Figure 9-24** Badges module: Advanced Gateway page

[Table 9-8](#) describes the settings for the Cisco Physical Access Gateway.

**Table 9-8** Badges Module: Cisco Physical Access Gateway Fields

Field	Description
<b>Temporary deactivation date</b>	(Optional) The start date to temporarily deactivate a badge. Click on the entry field to open a pop-up calendar, and then double-click to select a date.  For example, to deactivate a badge for a one-week vacation beginning January 1, select the date from the pop-up calendar, and then enter 7 in the following <b>duration</b> field.  If a date is entered, the badge deactivation begins at 12.00 AM on the specified day.
<b>Temporary deactivation duration</b>	(Optional) The duration of the temporary deactivation, in days. For example, to deactivate a badge for a 7 day vacation, enter 7.
<b>Use limit</b>	(Optional) The maximum number of times a badge can be used. When the limit is reached, the badge is deactivated.
<b>Role</b>	The role of the person who carries the badge: Employee, Contractor, Vendor, Temporary, Employee_full_time, Employee_part_time, Intern, Visitor, or Other.
<b>Executive credential</b>	If checked, specifies that the badge belongs to an executive.

## Badges module: Advanced EM-100 page

The Advanced EM-100 page is shown in [Figure 9-25](#).

**Figure 9-25** Badges module: Advanced EM-100 page

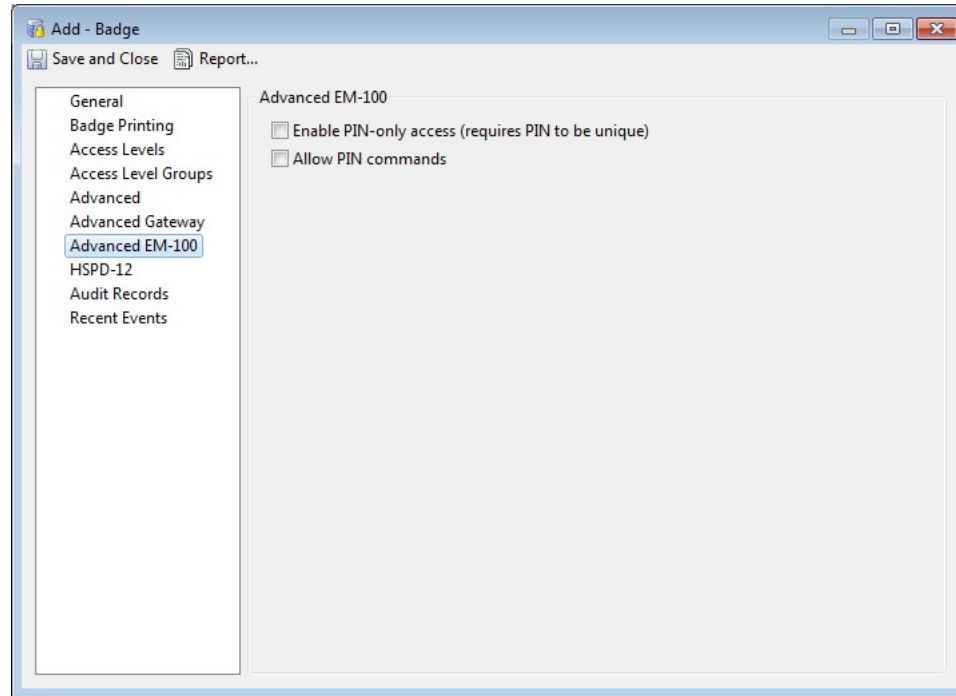

[Table 9-9](#) describes the fields appearing in this window.

**Table 9-9** Badges Module: Advanced EM-100 Fields

Field	Description
<b>Enable PIN-only access (requires PIN to be unique)</b>	Check this box to enable this badge to use PIN-only access at an EM-100 reader. This requires that the badge PIN be unique.
<b>Allow PIN commands</b>	Check this box to allow this badge to use PIN commands at an EM-100 reader.



### Note

The EM-100 controller provides a PIN commands feature that enables an authorized badge holder to lock and unlock a reader which has a keypad, by entering a command at that reader. After a reader has been locked, no one will be granted access to the door's protected area until the reader is unlocked, even if they would normally be able to gain access. After a reader has been unlocked, the normal access rules are applied again. An example of using PIN commands is a roaming security guard who locks specific readers controlling areas that are off-limits after hours, and then unlocks them prior to normal working hours.

Two things must be configured before the PIN commands feature can be used:

- The appropriate readers must have the **Enable PIN commands** option enabled (on the **Door** page of the **Edit - Door** dialog)

- The badge of the appropriate users must have the **Allow PIN commands** option enabled (on the **Advanced EM-100** page of the **Add - Badge** dialog)

Then badge holders who are authorized to use PIN commands can enter the following command codes at those readers:

**00\*** - Lock the reader, so no one can use it to gain access until it is unlocked (by the 99\* command).

**99\*** - Unlock the reader, to restore normal access.

## Badges module: HSPD-12 Badge Extension page

Table 9-10 describes the HSPD-12 Smart Card badge extension settings.



Note

The HSPD-12 badge extension is experimental and may be changed or removed in future ICPAM releases. For this reason, the extension should not be used in a production setting.

*Table 9-10 Badges Module: HSPD-12 Badge Extension Fields*

Field	Description
<b>Full name</b>	The full name of the card holder.
<b>Agency Code</b>	Identify the government agency issuing the credential.
<b>System Code</b>	Identifies the system that issued the card
<b>Credential Number</b>	The number encoded by the issuing agency. Only one credential number can be active in a system.
<b>Credential Series</b>	Credential series code used to reflect major system changes.
<b>ICI</b>	Individual Credential Issue code. Initially it is set to 1 and incrementally increased by 1 if the card is replaced, damaged, or lost. For example, the ICI for a replacement card would be 2.
<b>FASC-N</b>	The Federal Agency Smart Credential Number. This data is in the BCD (Binary coded decimal) format and is comprised of fields such as Agency Code, System Code, Credential Number, Credential Series, Individual Credential Issue code, and other fields.
<b>Expiration date</b>	The date the credential expires and is deemed invalid.
<b>Card Type</b>	The specified Smart Card credential type. The currently supported type is PIV.



## Badges module: Audit Records page

When an operator adds, deletes, or modifies a record, an audit record is generated. The following information is included in each audit record:

*Table 9-11 Badges Module: Audit Records Fields*

Field	Description
<b>Time</b>	The time and date when the modification occurred.
<b>Type</b>	The type of change made.
<b>Description</b>	A description of the modification: what type of record was modified, and whether it was inserted, updated, or deleted.
<b>Device</b>	The name of the workstation device where the modification occurred.
<b>Credential</b>	The login that the operator was logged in with when the modification occurred.
<b>Data</b>	Additional information about the modification.
<b>View Current...</b>	Opens a new window displaying the current settings.
<b>View Before...</b>	Opens a new window displaying the settings before the change was made.
<b>View After...</b>	Opens a new window displaying the settings after the change was made.

## Badges module: Recent Events page

Lists the recent events of the selected badges. Use the **View**, **Report**, and **Filter** buttons for increased functionality. The following fields are listed in the recent events list:

*Table 9-12 Badges Module: Recent Events Fields*

Field	Description
<b>Time</b>	The time and date when the event occurred.
<b>Description</b>	A description of the event.
<b>Device</b>	The device associated with the event.
<b>Address</b>	The address of the device.
<b>Personnel Record</b>	The personnel record associated with the event.
<b>Data</b>	This field displays detailed information about the event, the exact value and meaning of which depends on the type of event. This field is generally for advanced or troubleshooting use. If the event is associated with an attempt to gain access to an access point using a badge that is not in the database, then this field contains the card number.
<b>Credential</b>	If the event has an associated credential (such as a badge or login), the identifying information of the credential (such as a card or username) is displayed in this field.
<b>Site</b>	The site where the event occurred.

## Badge Authentication

The **Authenticate Credential** door command is used to check if a specified badge ID will be authenticated at a future time.

Procedure

- 
- Step 1** Go to **Doors** -> **Hardware Tree**.
- Step 2** Right-click the door and select the **Authenticate Credential** command from the pop-up menu.

*Figure 9-26 Authenticate Credential command*

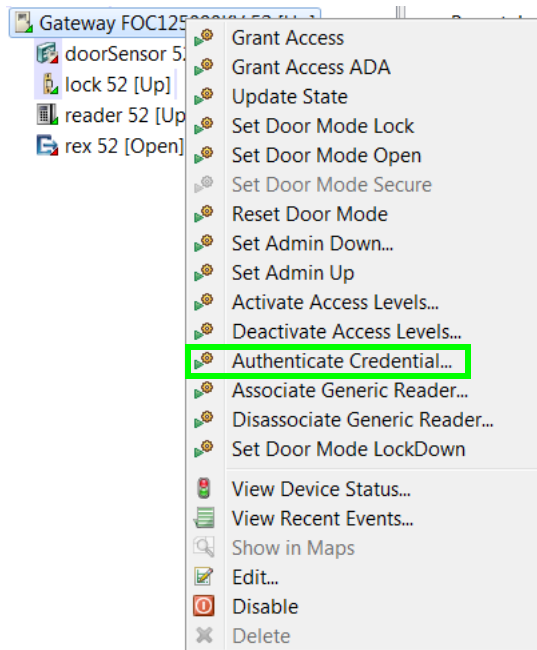

- Step 3** In the resulting dialog, specify the badge ID and timestamp.
- Step 4** Select the **Gateway** option to perform badge authentication at the controller. A Grant Access or Deny Access message is displayed.  
or  
Select the **ICPAM** option to perform badge authentication at the ICPAM server. A Grant Access or Deny Access message is displayed.
- 

## Usage Notes

- The **Authenticate Credential** command supports only a future date & time.
- Doors without an associated anti-passback (APB) policy can verify badge authentication at both the ICPAM server and the controller (one at a time).
- Doors configured with an APB policy can only verify badge authentication at the ICPAM server.
- The **Authenticate Credential** command can be issued on APB doors only for APB exempt badges. If the APB rule is enforced for a badge, the command response is always “Access denied”.

- This command is not available for the doors configured under Two Door Policy.

## Limitations

- The **Authenticate Credential** door command does not support facility code based authentication (if the door is configured based on facility code authentication).
- The command does not authenticate the badge based on a Badge ID and Pin Number combination.
- The command does not support Pin Exempt and ADA features.
- The command does not support any properties associated with the door (such as door schedules, door admin down, door admin up), its associated devices & its properties (such as Reader configurations), and door commands (except the **Deactivate Access Policies** and **Activate Access Policies** commands).
- The **Authenticate Credential** door command does not validate based on APB entry/exit in the limitation field.

## Using the Badge Designer

Use the **Badge Designer** to create and modify badge designs as described in the following instructions.

- Step 1** Select **Badge Designer** from the **Admin** menu. The main window of the **Badge Designer** module displays all badge templates loaded into the system.

*Figure 9-27 Badge Designer main window*

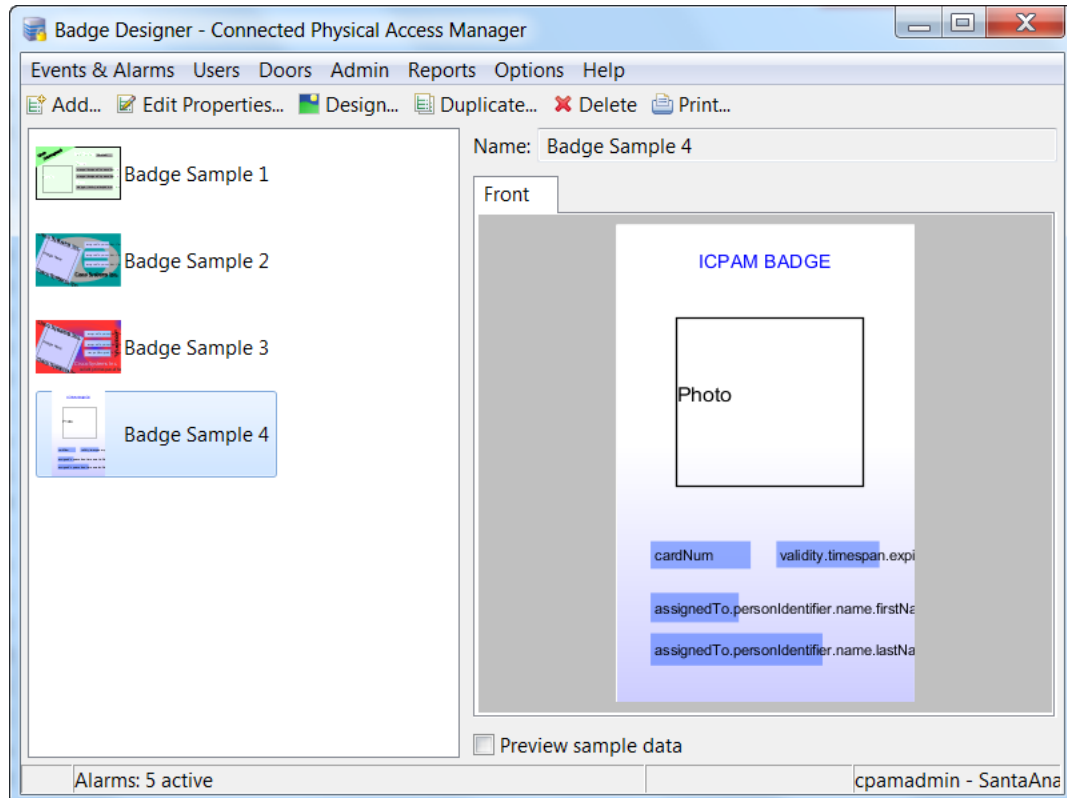

- Step 2** Do one of the following:
- View or modify an existing template:
    - Click an existing template name to view details of the template. Click the **Front** and **Back** tabs in the design window to view both sides of the badge template. Select the **Preview Sample Data** check box to preview the badge template with sample data, if included in the template design.
    - Click **Properties...** to edit the name and size of the badge template. Skip to [Step 4](#) for instructions.
    - Click **Design...** to edit the graphic design of the badge template. Skip to [Step 6](#) for instructions.
    - Click **Duplicate...** to create a duplicate of the badge template.
    - Click **Delete...** to delete the badge template.
    - Click **Print...** to print a test badge template.
    - **Click Add...:** to add a new badge template, as described in the following steps.

**Step 3** To create a new template, click **Add...** to open the **SVG Badge Format** window, as shown in [Figure 9-28](#).

*Figure 9-28 New Badge Format*

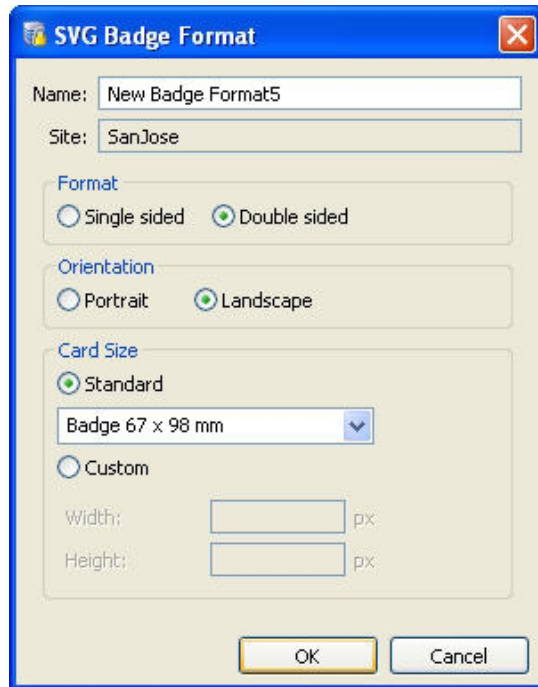

**Step 4** Enter the template properties:

- a. **Name:** Enter a descriptive name.
- b. **Format:** Select if the badge is single sided or double sided.
- c. **Orientation:** portrait or landscape.
- d. **Card Size:** Select a standard size, or enter custom dimensions. Standard size options include:
  - CR-80 Flush Cut 54 x 85.7mm
  - CR-80 Lip Seal 48 x 80mm
  - Badge 67 x 98mm
  - Badge 79 x 99mm
  - IBM 59 x 82.5mm



**Tip**

To modify an existing template, select the template name from the main window and click the **Design** button. To edit the properties of an existing template, click the **Properties** button.

**Step 5** Click **OK**.

The **Badge Format** opens in the format, orientation, and size configured in [Step 4](#). For two-sided badges, there is a separate window for the front and the back of the templates, as shown in [Figure 9-29](#).

Figure 9-29 Badge Design Editor

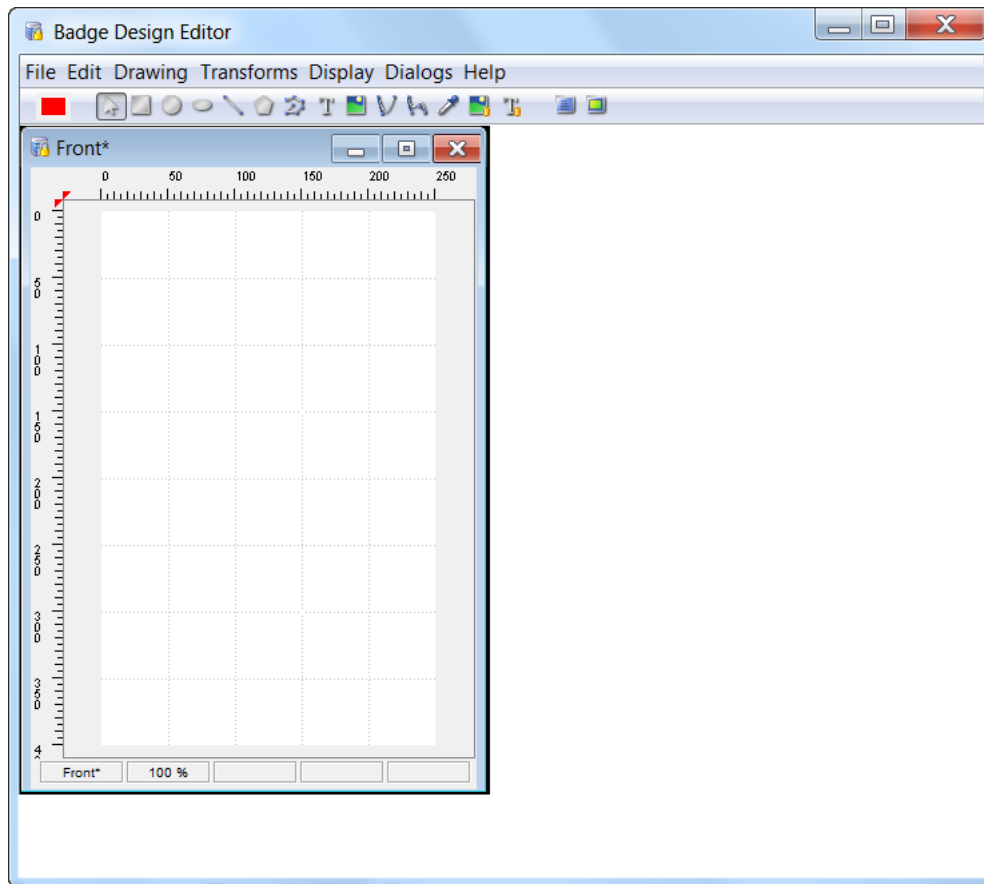

**Step 6** Use the toolbar icons (located below the menu bar) to design the template. The icons include the following tools (from left to right):

**Tip**

Hold the mouse cursor over an icon to view the icon title.

- **Color:** Click the icon to select a color, and then drag-and-drop the color onto a shape to apply that color.
- **Mouse Pointer Tool:** Select and move objects on the badge template.
- **Rectangle Tool:** Draw rectangle objects.
- **Circle Tool:** Draw a circle.
- **Ellipse Tool:** Draw an ellipse.
- **Line Tool:** Draw a line.
- **Polygon Tool:** Draw a polygon.
- **Polyline Tool:** Draw an a polygon with operator defined line lengths.
- **Text:** Add text to the template.
- **Image:** Add an image to the template.
- **Quadratic Bezier Curve:** Create a line between 3 points.

- **Cubic Bezier Curve:** Create a line between 4 points.
- **Color Picker Tool:** Select a color from the palette.
- **Image Link:** Create an image link to the ICPAM database. Options include: personnel photos or signatures.
- **Text Link:** Create a text link to the ICPAM database. Options include: **Personnel** and **Badge Manager** fields.
- **Properties:** Properties available for the selected object.
- **Resources:** Resources of the selected object.

**Step 7** Draw a rectangle, as shown in [Figure 9-30](#).

*Figure 9-30 Badge Designer Editor: Rectangle Tool*

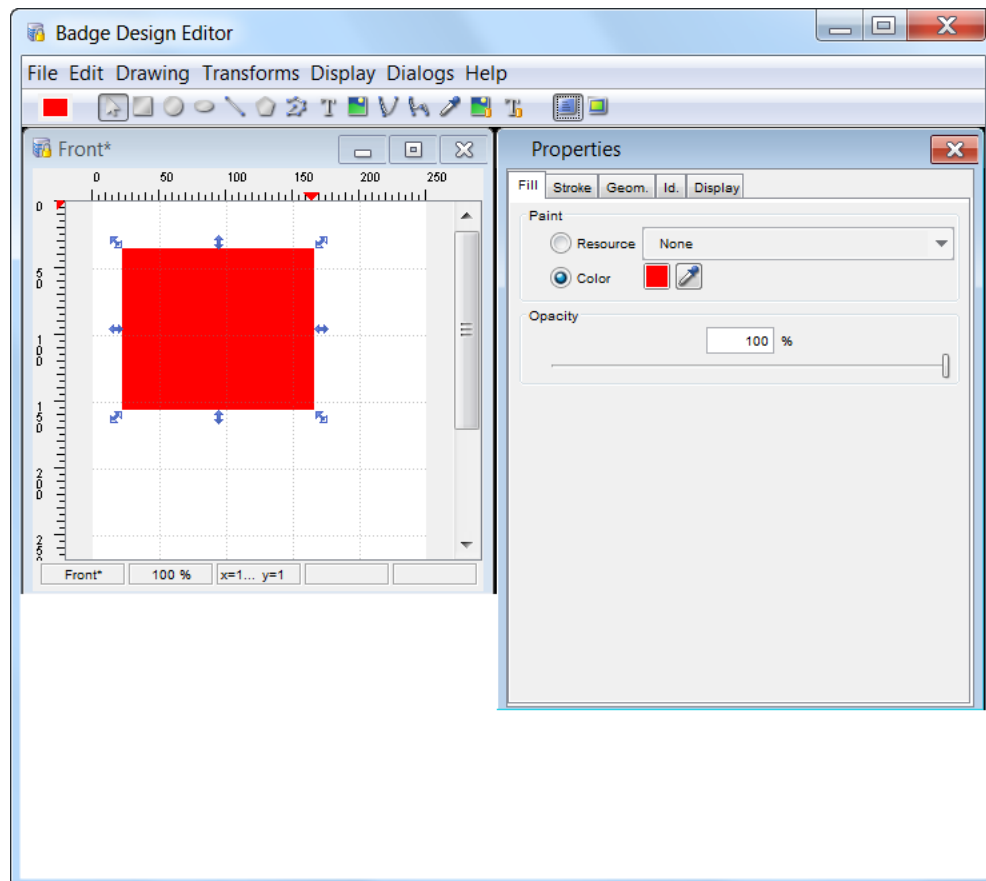

- Click the rectangle button in the toolbar, and drag a rectangle onto the badge template.
- To edit the colors of the rectangle, click the **Color** button on the left side of the **Tool Bar**.

**Step 8** Select a stroke color for the badge. The stroke is the outline of the rectangle.

- Select the rectangle on the badge template to display blue arrows at each corner.
- In the **Properties** section, select the **Stroke** tab.
- With the **Color** radio button selected, use the **Color picker** and choose a desired stroke color.
- Select an appropriate width value. The **Width** field increases the size of the stroke.

- g. Press **Enter** or click outside of the field to apply the setting.
- Step 9** Select a fill color for the badge. The fill is the color of the rectangle.
- a. Click the **Normal** button (displayed as an arrow) in the **Tool Bar**.
  - b. Select the rectangle on the badge template. The rectangle is displayed with blue arrows at each corner.
  - c. In the **Properties** section, select the **Fill** tab.
  - d. With the **Color** radio button selected, use the **Color picker** and choose a desired fill color.
  - e. Press **Enter** or click outside of the field to apply the setting.
- Step 10** Add a logo to the badge template:
- a. Click the **Image** button.
  - b. On the template, click and drag a rectangle at a desired location for the logo to open the image browser.
  - c. Select an image with a supported file type (.jpg, .png, or .svg) on a local drive and click **Open**. The logo appears in the box, as shown in [Figure 9-31](#).
  - d. Click and drag the logo to a desired location.

*Figure 9-31 Badge Design Editor: Logo*

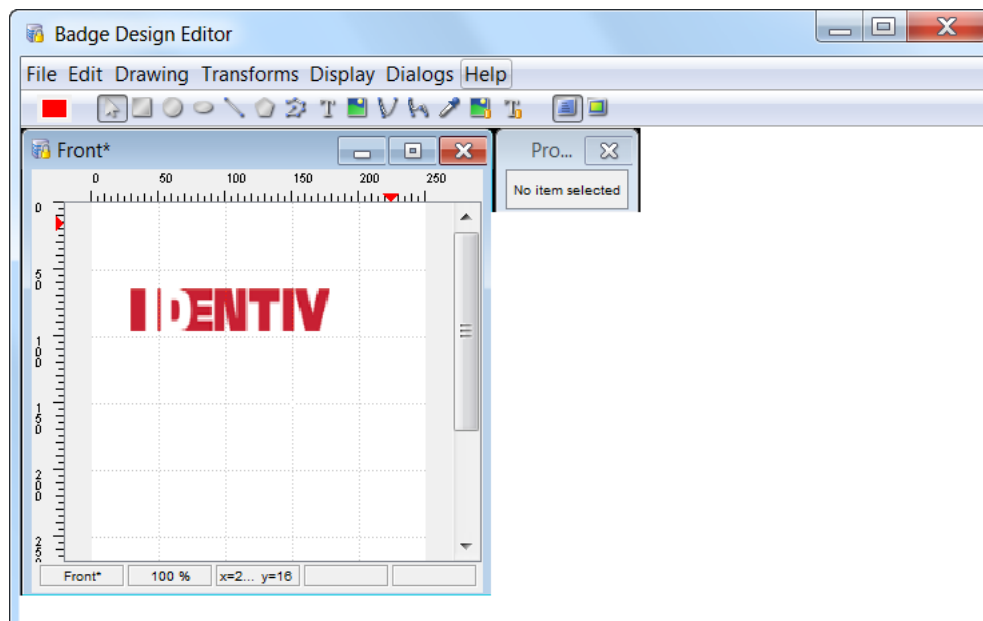

- Step 11** To add a dynamic text field to the badge template:
- a. Click the **Text Link** button in the toolbar.
  - b. In the **Properties** section, select the **Database Text Link** tab, as shown in [Figure 9-32](#).
  - c. In the field drop-down, select the correct text link. This text link extracts the field from the database. For example, the **Title** text link field extracts the personnel title from the database.
  - d. (Optional) In the **Properties** section, select the other attributes of the text, such as size and font.
  - e. Click and drag the text to a desired location.



Figure 9-32 Badge Design Editor: Database Text Link

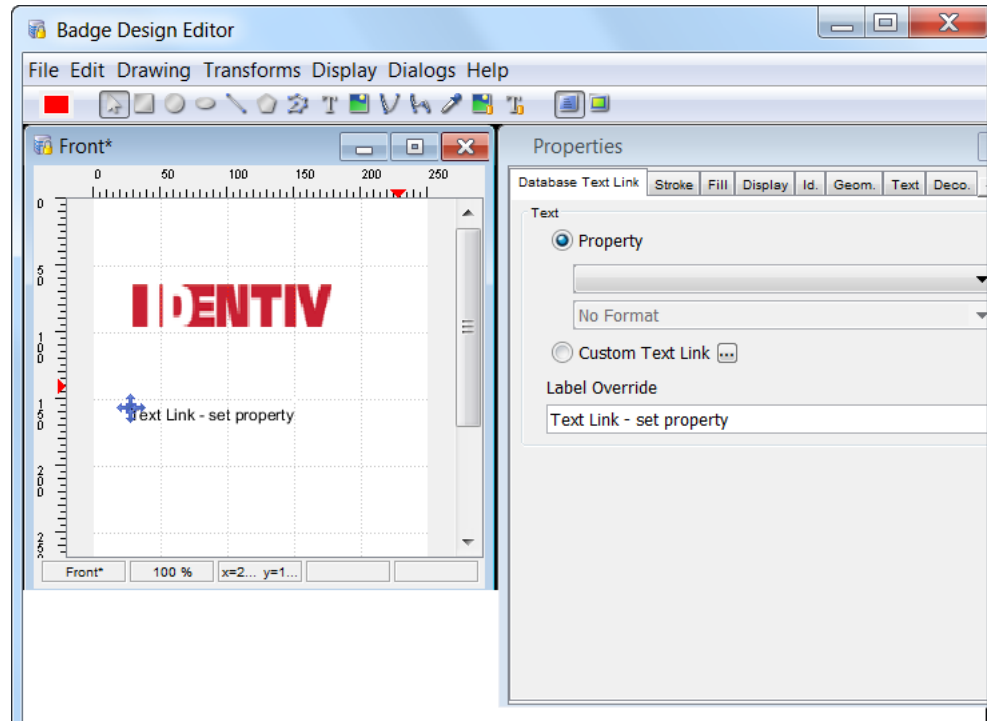

- Step 12** To add a dynamic image to the badge template:
- Click the **Image Link** button in the **Tool Bar**.
  - Click and drag a rectangle on the badge temptingly where the image will appear.
  - In the **Properties** section select the **Database Image Link** tab.
  - In the field drop-down select **Photo**, as shown in [Figure 9-33](#). This object extracts the photo from the personnel database.
  - Click and drag the box to a desired location.

**Tip**

Select **Optimize Images** from the **File** menu to resize all photos to the area they occupy on the badge. If the photos do not optimize with sufficient resolution, you may need to manually resize photos in an external photo editor to achieve the best possible print quality. See [Printing High Resolution Images, page 9-55](#) for more information.

Figure 9-33 Badge Design Editor: Database Image Link

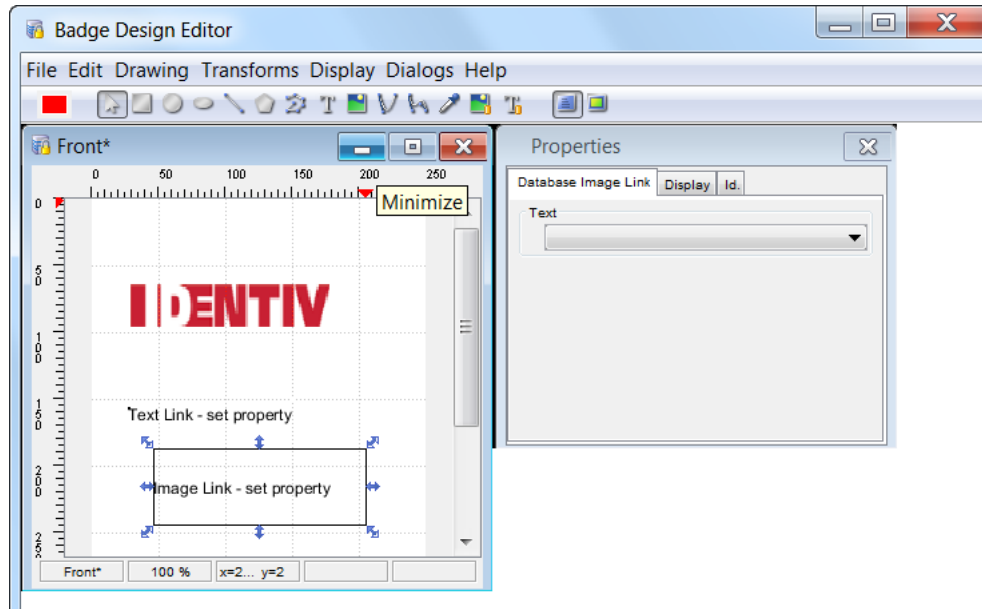

**Step 13** Click the **File** button and select **Save All** to save changes.

**Step 14** Click the **File** button and select **Exit** to close the **Badge Format**.

The new template appears in the **Badge Designer**, as shown in [Figure 9-34](#).

Figure 9-34 Badge Designer With New Template

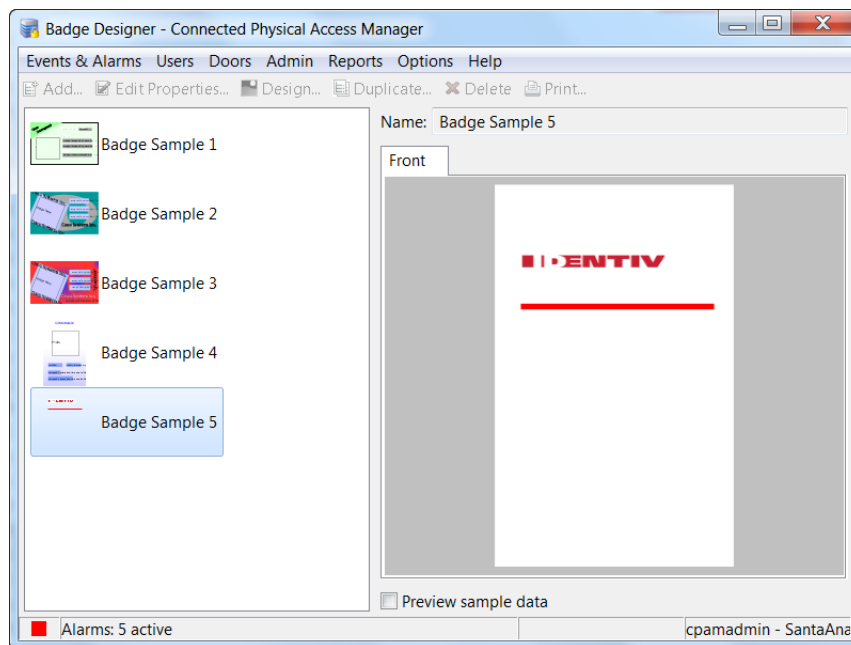

## Installing and Using a Barcode Font

To use barcode fonts for printing certain fields on a badge that is designed using the ICPAM Badge Designer, you can add the desired font to the Windows PC and use it with the Badge Designer.

To install the barcode font, follow the process:



**Note** For the following process, 3 of 9 barcode font is used.

- Step 1** Download 3 of 9 font using attached font or from a Web page.
- Step 2** Unzip the font archive.

*Figure 9-35 Documents and settings window*

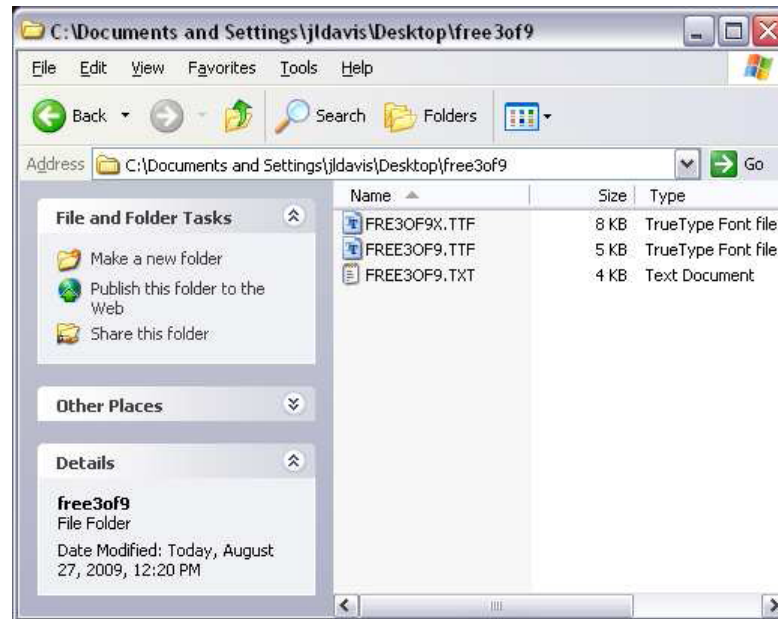

- Step 3** Navigate to **Settings > Control Panel > Fonts**.
- Step 4** Click **File > Install > New Font**, and browse to the location of the unzipped font files

Figure 9-36 Add Fonts

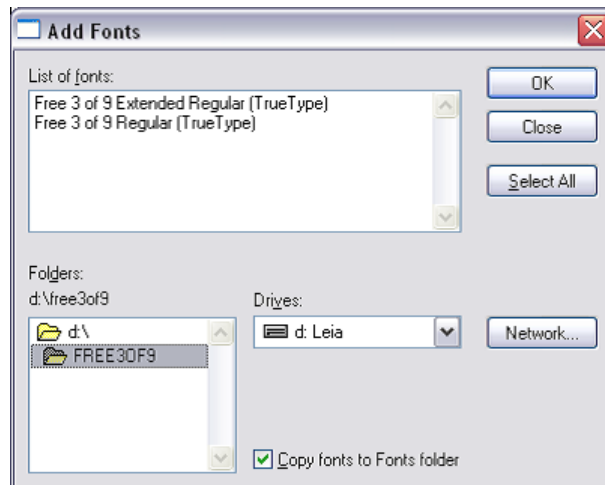

- Step 5 Select the required fonts, and click **OK**.
- Step 6 Run ICPAM client and navigate to the Badge Designer.
- Step 7 Add a text or a text link.

Figure 9-37 Badge Format - Adding a Text

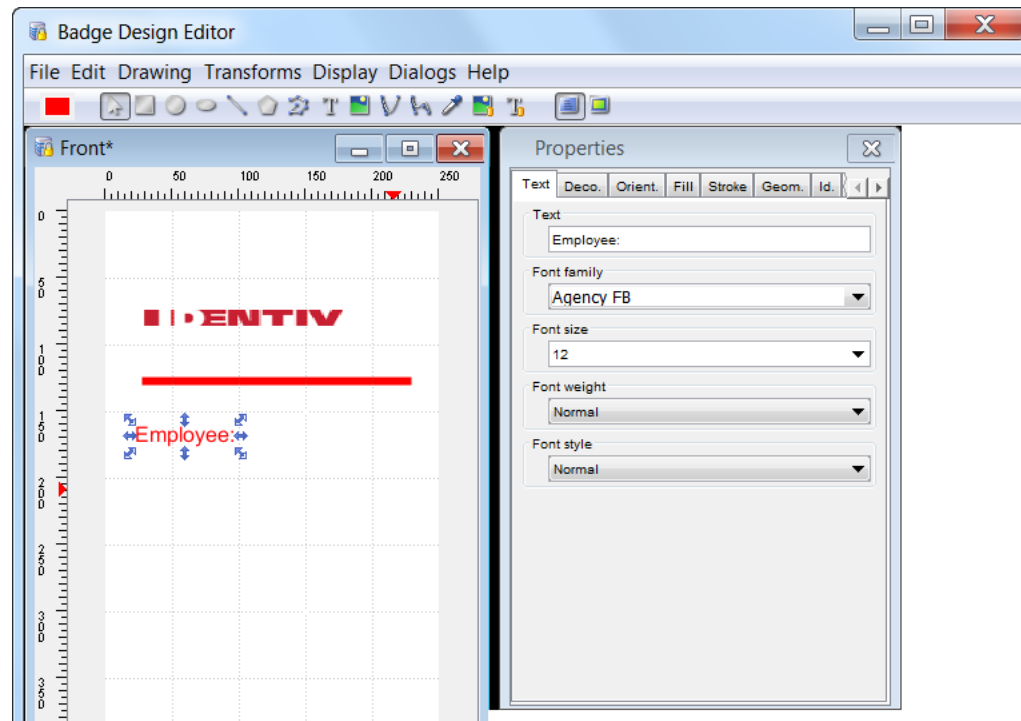

Figure 9-38 Badge Properties - Show Properties

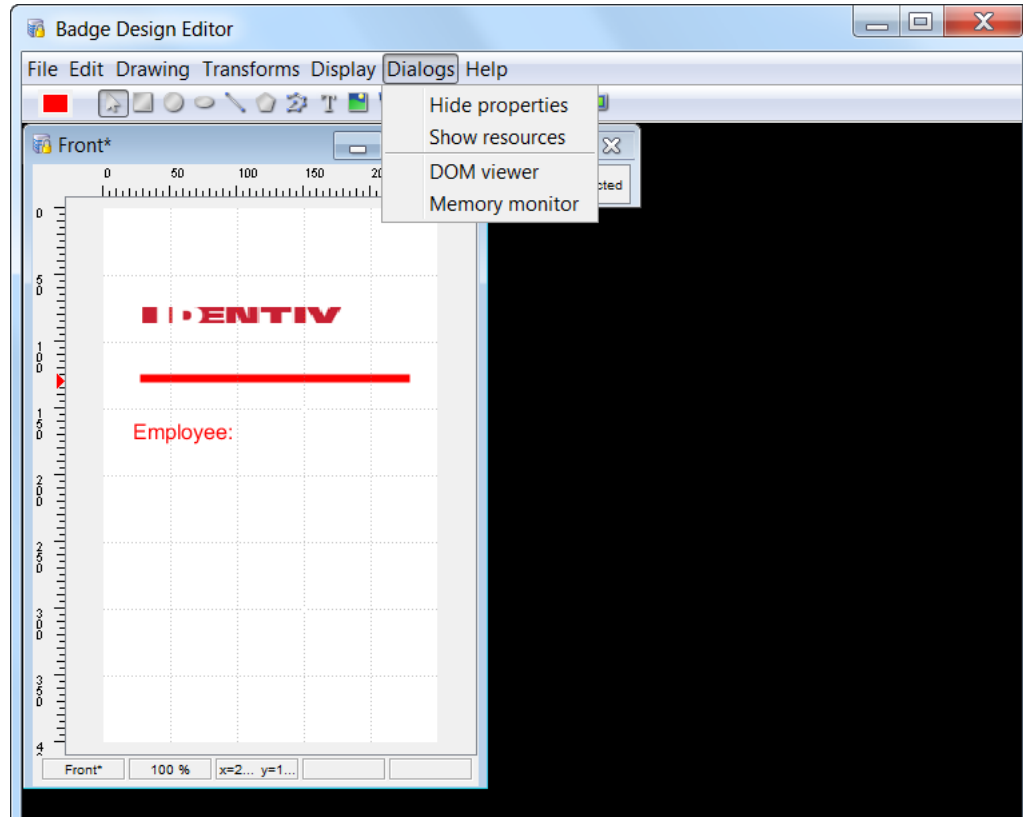
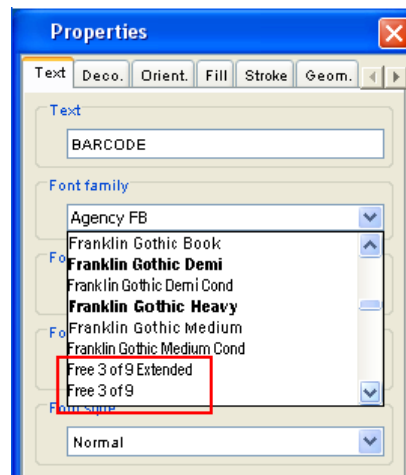
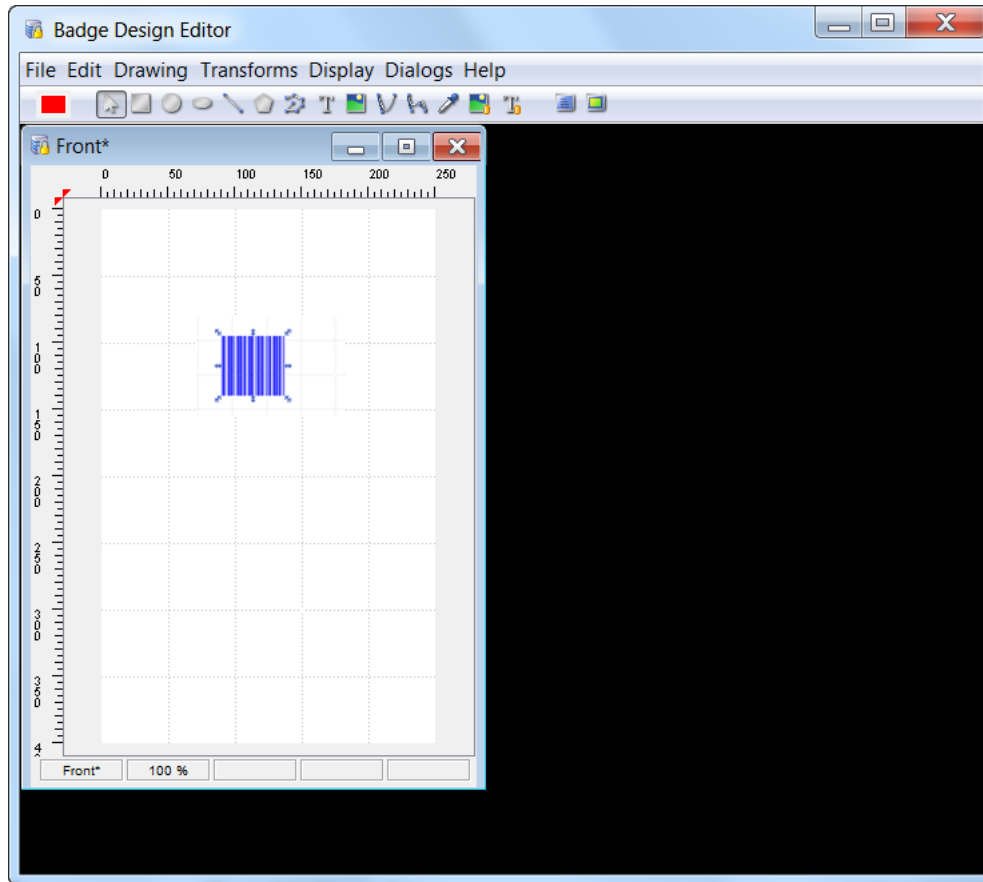

Figure 9-39 Properties Window



- Step 8** From the **Properties** window, choose the **Text** tab.
- Step 9** From the **Font family** drop-down list, choose the installed **Free 3 of 9** font.

Figure 9-40 Badge Barcode Example



## Printing Badges

To print badges, you must first assign a format to the badge (designs created using the badge designer, as described in [Badge Authentication, page 9-36](#)).

After a design is assigned to the badge, you can print badges individually, or in groups.



### Note

To print multiple badges at once, you must also enable the batch printing feature. See [Printing Multiple Badges, page 9-51](#) for instructions.

This section includes the following information:

- [List of Recommended Badge Printers, page 9-49](#)
- [Printing Individual Badges, page 9-50](#)
- [Printing Multiple Badges, page 9-51](#)
- [Printing High Resolution Images, page 9-55](#)
- [Changing the Default Badge Printer, page 9-56](#)
- [System Configuration Settings for Badge Printing, page 9-57](#)

## List of Recommended Badge Printers

The following recommended printers have either been used with ICPAM or have been tested and verified as capable printers. To use these printers with ICPAM, you must correctly install the printer drivers prior to printing.

**Note**

---

ICPAM sends a simple command to the printer that allows the system to communicate with most printer manufacturers. Before purchasing a printer, verify the printer drivers work with the operating system for your client computer, and with ICPAM.

---

The recommended printers are:

**Fargo Printers ([www.fargo.com](http://www.fargo.com))**

- HDP600 Card Printer
- HDP600 CR100 Card Printer
- HD5000 Card Printer
- HD4000 Card Printer
- DTC400 Card Printer
- DTC400e Card Printer
- DTC550 Card Printer
- DTC1000 Card Printer
- DTC4000 Card Printer
- DTC4500 Card Printer
- Persona C30e Card Printer
- Persona C30 Card Printer

**Magicard Printers ([www.ultramagicard.com](http://www.ultramagicard.com))**

- Enduro Card Printer
- Rio2e Card Printer
- Rio Pro Card Printer
- Tango 2e Card Printer
- Tango +L Card Printer
- Prima 3 Card Printer
- Alto Card Printer
- Avalon Card Printer
- Tempo Card Printer
- Opera Card Printer

**Evolis Printers ([www.evolis.com](http://www.evolis.com))**

- Dualys 3
- Pebble 4
- Securion

**Datacard Printers ([www.datacard.com](http://www.datacard.com))**

- SD360

**Zebra Printers ([www.zebra.com](http://www.zebra.com))**

- 110i
- 330i
- P430i

## Printing Individual Badges

To print a single badge, do the following:

- Step 1** (Optional) Create the badge formats (designs), as described in [Using the Badge Designer, page 9-38](#). You can also use one of the designs provided with ICPAM.
- Step 2** To define a badge format for a single badge, do the following:
- Select **Badges** from the **User** menu.
  - Right-click a badge and select **Edit** from the pop-up menu.
  - Click the **Badge Printing** tab and select a **Format**, as shown in [Figure 9-41](#).
  - Click **Print**.

**Tip**

If a format is already assigned for the badge, you can print from the main window. Click to highlight the badge, and then select **Print Selected Items** from the **Print** menu. If a format is not defined, however, the print job will fail. To view the status of print jobs, select **Batch Badge Printing** from the **User** menu.

**Figure 9-41** Printing a Single Badge

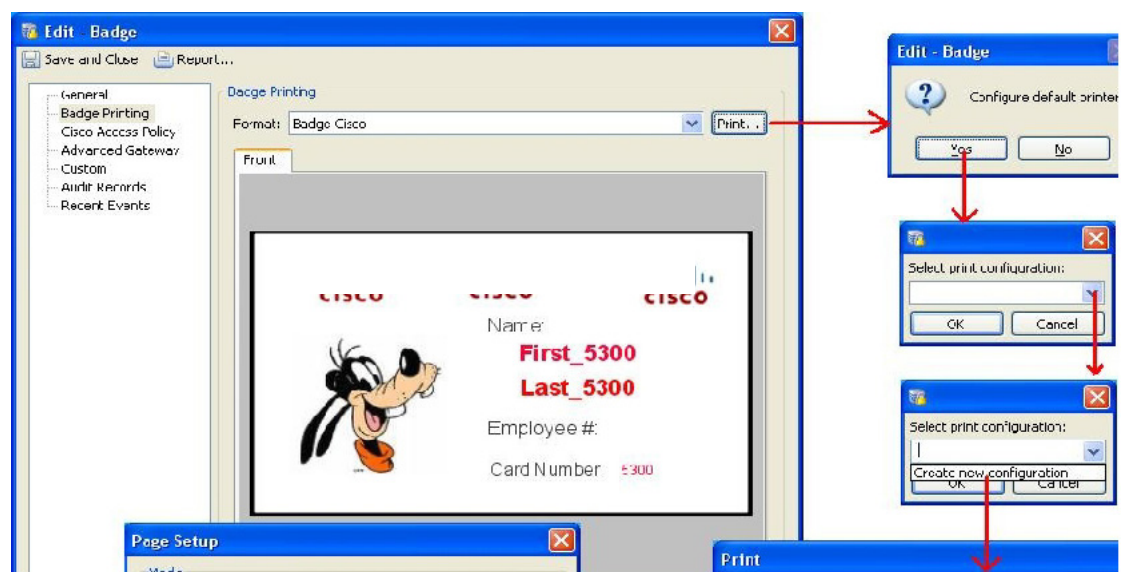

- Step 3** Configure a default printer, as shown in [Figure 9-41](#).



These steps only occur if a default printer is not configured.

- a. Click **Yes** to configure the default printer. This defines the printer used to print ICPAM badges.
  - b. In the **Select print configuration** window, select **Create new configuration**.
  - c. In the **Print** window, select a printer, and click **OK**.
  - d. In the **Page Setup** window, adjust the settings if necessary, and click **OK**.
  - e. Enter a name for the printer configuration and click **OK**. For example: `USB Printer`.
  - f. Wait for the badge to print on the selected printer. To view the status in the print job, select **Batch Badge Printing** from the **Admin** menu.
- 

## Printing Multiple Badges

To print multiple badges in batch mode, do the following:

- 
- Step 1** (Optional) Create the badge formats (designs), as described in [Using the Badge Designer, page 9-38](#). You can also use one of the designs included with ICPAM.
  - Step 2** Enable batch badge printing.
    - a. Select **System Configuration** from the **Admin** menu.
    - b. Select **Badge Printing**, as shown in [Figure 9-42](#).
    - c. Uncheck the **Disable batch badge printing** box.
    - d. Log out and log back in to the ICPAM application to activate the changes (select **Logout** from the **Options** menu).

Figure 9-42 Enabling Batch Badge Printing

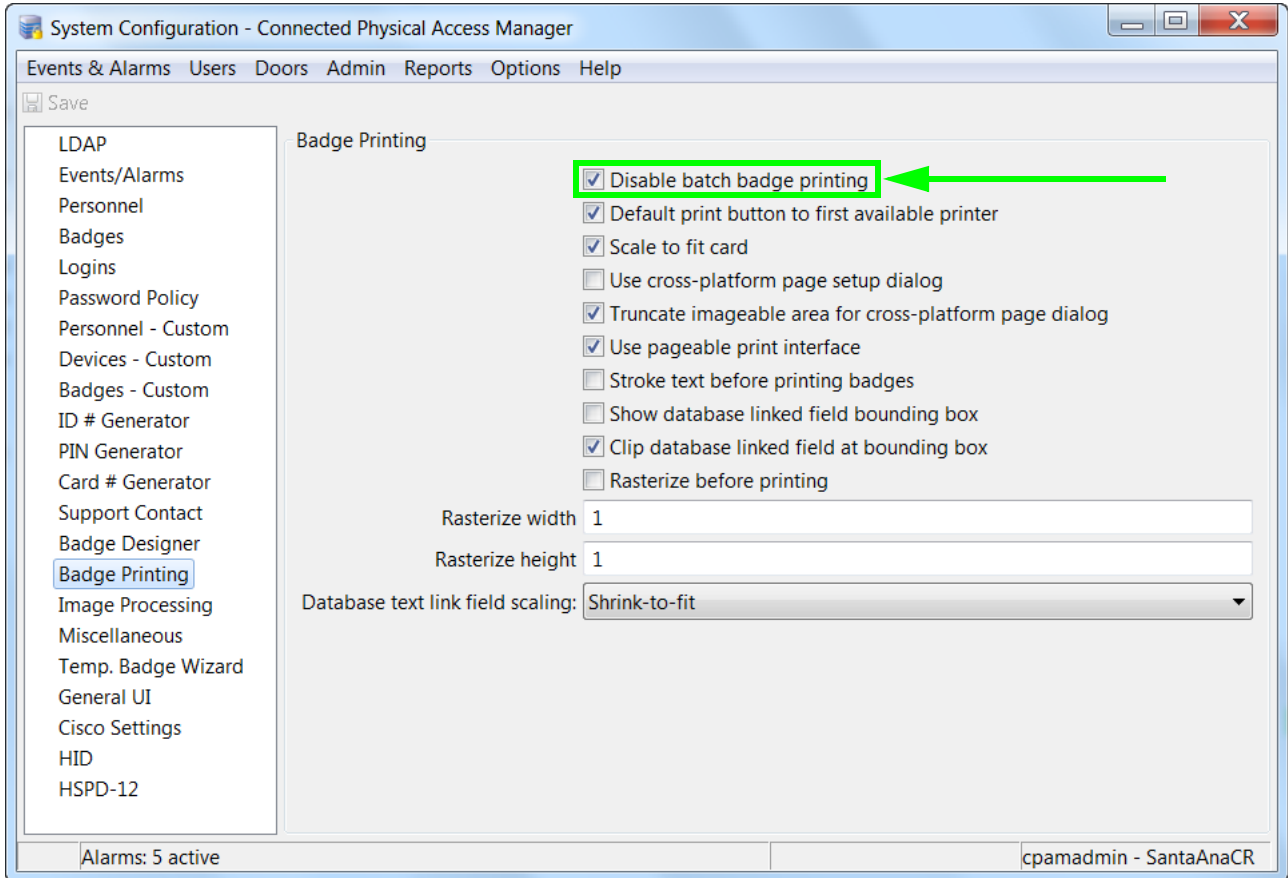

**Step 3** Define the format for the badges to be printed.



**Tip** If a format is already assigned for all of the selected badges, skip to [Step 4](#). Check the Format column to view the assigned format, if any ([Figure 9-43](#)).

- a. Select **Badges** from the **User** menu.
- b. (Optional) Shift-click or control-click to select multiple badges.
- c. Click the **Group Edit** menu and select **Group Edit All Items** or **Group Edit Selected Items** from the drop-down menu ([Figure 9-43](#)).

Figure 9-43 Group Edit Badges

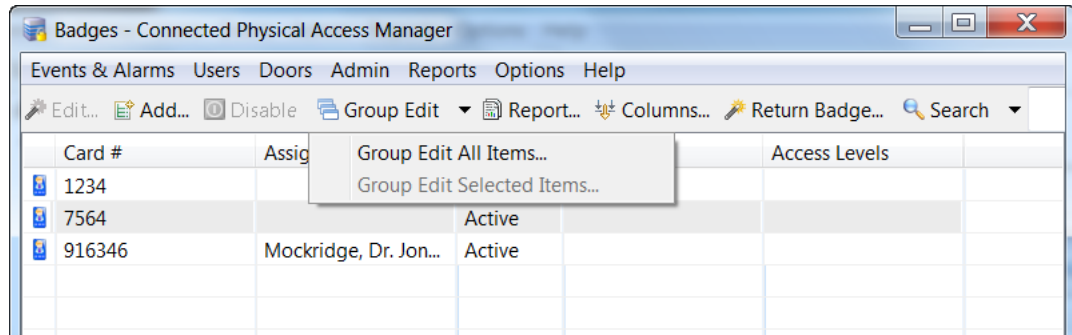

- d. Click the **Badge Printing** tab, and check the **Design** check box as shown in Figure 9-44.
- e. Select a format and click **OK**.

Figure 9-44 Badge Printing Format for Multiple Badges

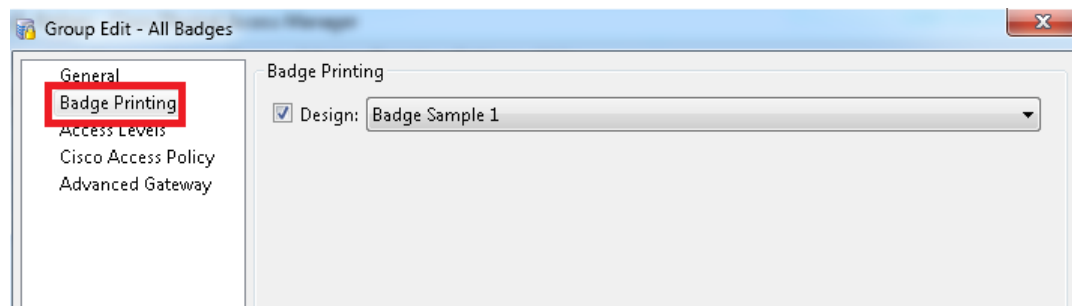

#### Step 4 Print the badges.



**Note** If a format is not assigned for any of the selected badges, as described in Step 3, the print job will fail. To view the status of print jobs, select **Batch Badge Printing** from the **User** menu.

- a. Select **Badges** from the **User** menu, if necessary.
- b. Shift-click or control-click to select multiple badges.
- c. Click the **Print** menu and select **Print All Items** or **Print Selected Items** from the drop-down menu (Figure 9-45).

Figure 9-45 Printing Multiple Badges

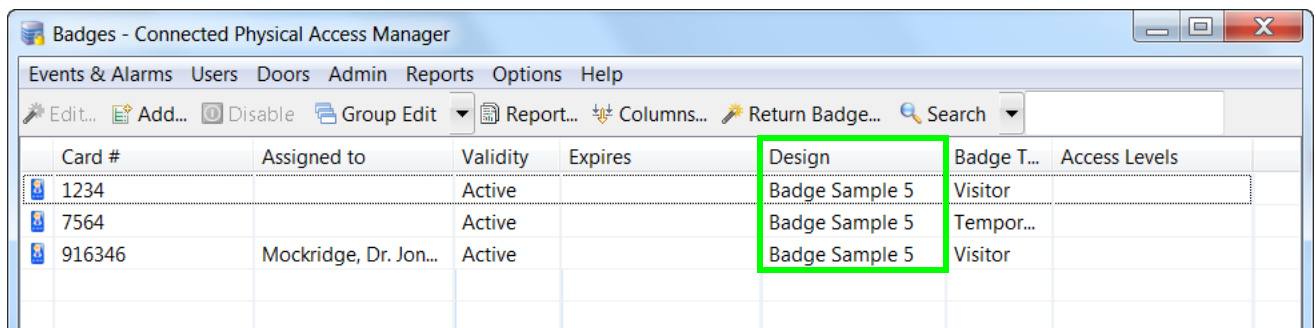

- Step 5** (Optional) Configure a default printer, as shown in [Figure 9-41 on page 9-50](#). These steps only occur the first time you print a badge.
- Click **Yes** to configure the default printer. This defines the printer used to print ICPAM badges.
  - In the **Select print configuration** window, select **Create new configuration**.
  - In the **Print** window, select a printer, and click **OK**.
  - In the **Page Setup** window, adjust the settings if necessary, and click **OK**.
  - Enter a name for the printer configuration and click **OK**. For example: USB Printer.



**Tip** To change the default printer, see [Changing the Default Badge Printer, page 9-56](#).

- Step 6** Select a **Batch Printing Option**, as shown in [Figure 9-46](#).

*Figure 9-46 Batch Printing Options*

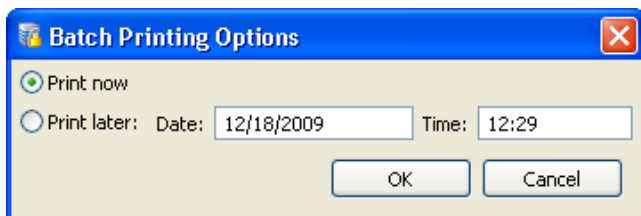

- Select **Print Now** to print the badges immediately.
- Select **Print Later** and enter a **Date** and **Time** to automatically print the badges later.
- Click **OK** to print the badges.

- Step 7** To view the status of the print job, do the following:

- Select **Batch Badge Printing** from the **Admin** menu, as shown in [Figure 9-47](#).

Figure 9-47 Batch Badge Printing Status

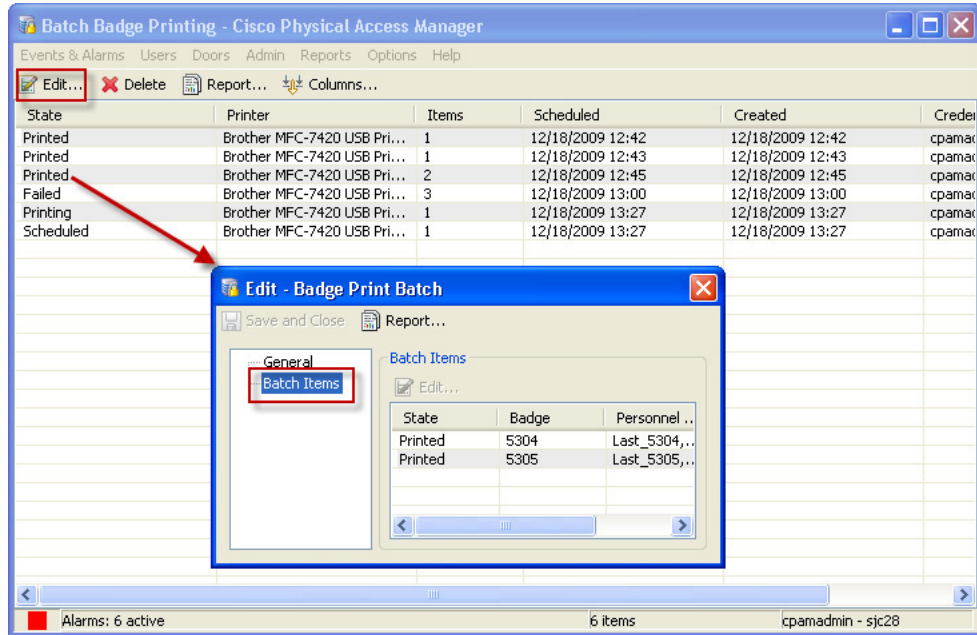

- b. Click on the print job to select it, and click **Edit**.
- c. Select **Batch Items** in the Badge Print Batch window to view the items included in the print job.

**Tip**

If the **State** of the print job is `Failed`, verify that a **Format** is assigned to every selected badge, as described in [Step 3](#).

## Printing High Resolution Images

The highest possible photo print quality is achieved when the resolution of the photo matches the print resolution of the printer: the target width and height of the photo should be multiplied by the printer resolution.

For example, if you are using a 300 dpi (dots-per-inch) printer, the ideal photo resolution that will occupy a 1 x 1 inch area is 300 x 300 pixels, a 2 x 2 inch area is 600 x 600 pixels, and a 2 x 3 inch area is 600 x 900 pixels.

Mathematically, the ideal resolution can be calculated as  $(rX, rY) = (w \cdot \text{DPI}, h \cdot \text{DPI})$  where:

- $(rX, rY)$  is the resolution of the photo
- $rX$  is the number of pixels in width
- $rY$  is the number of pixels in height
- $w$  is the target width of the image on the badge
- $h$  is the target height of the image on the badge
- $\text{DPI}$  is the resolution (dots-per-inch) of the printer

The **Badge Format** includes a function to automatically optimize images.

1. Select **Badge Designer** from the **Admin** menu.
2. Click the Design button to open the **Badge Format**.
3. Select **Optimize Images** from the **File** menu to resize all photos in the template to the area they occupy on the badge.



**Note**

If the photos do not optimize with sufficient resolution, you may need to manually resize photos in an external photo editor to achieve the best possible print quality.

## Changing the Default Badge Printer

The default printer is configured when you print a badge. Complete the following instructions to remove the default printer and select a new printer.

- Step 1** Select **Preferences** from the **Options** menu.
- Step 2** Click the **Badge Printers** tab.
- Step 3** In the Configurations section, select the printer that displays **Badge: Badge Printing** in the **Applies to** section, as shown in [Figure 9-48](#).

*Figure 9-48 Removing the Default Badge Printer*

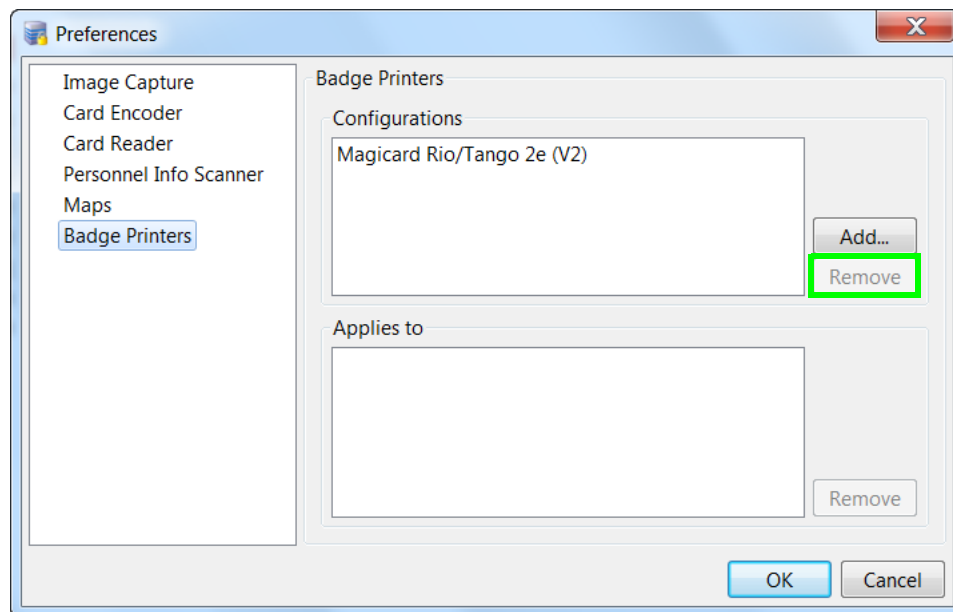

- Step 4** Select **Badge: Badge Printing** and click **Remove**.
- Step 5** Click **OK** to save the changes and close the window.
- Step 6** To set a new default printer, print a badge as described in [Printing Individual Badges, page 9-50](#) or [Printing Multiple Badges, page 9-51](#). When printing, you will be prompted to select a new default badge printer.

## System Configuration Settings for Badge Printing

Options for badge printing are available in two System Configuration screens:

- **Data Entry/Validation - Badge**
- **Miscellaneous**

This section describes the settings and options available in each window.

- Step 1** Select **System Configuration** from the Admin menu.
- Step 2** Select **Data Entry/Validation - Badge** (Figure 9-49).

**Figure 9-49** Badge Printing Options in Badges

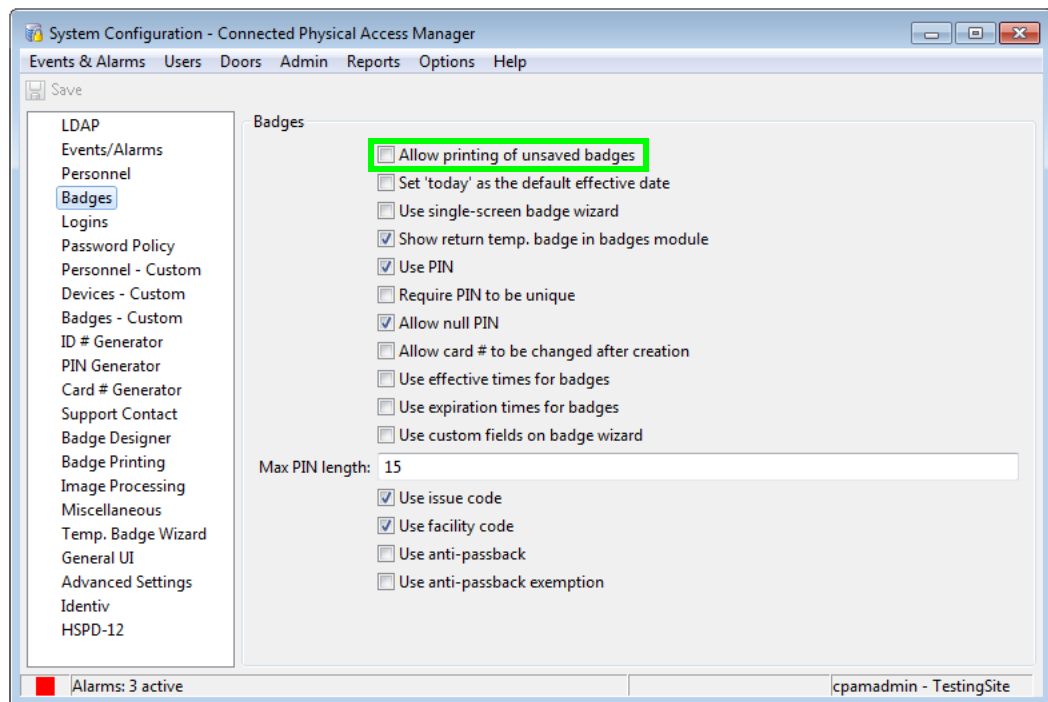

- Step 3** Select or deselect one or more of the following options.

**Table 9-13**

Field	Description
<b>Allow printing of unsaved badges</b>	Allows printing new badges before the badge is saved. For highest security, leave this unchecked. When allowed, it is possible to print a badge without having any record of the badge.

- Step 4** Select the **Badge Printing** tab (Figure 9-50).

Figure 9-50 Badge Printing Options in Badge Printing Settings

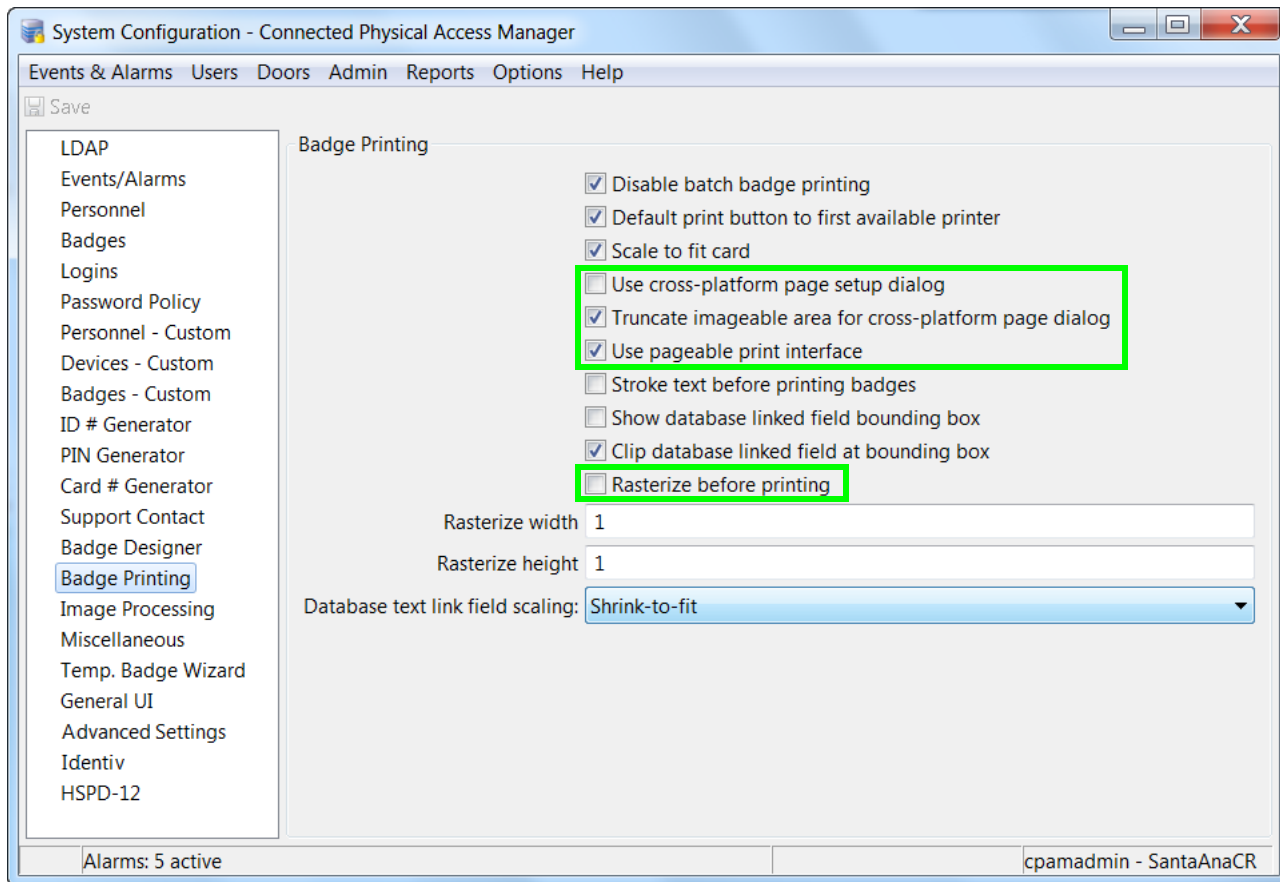

**Step 5** Select or deselect one or more of the following options.

Table 9-14

Field	Description
<b>Use cross-platform page setup dialog for badge printing</b>	Select this option to use the cross-platform Java page dialog if the badge image is truncated. This occurs when using the default printer dialog on some printers (such as the Zebra printer).
<b>Truncate imageable area values used to initialize cross-platform page dialog</b>	If the image is still truncated using the cross-platform Java page dialog, select this option to apply 0.01 inch margins.
<b>Use pageable print interface for badge printing</b>	The Java Printable printing interface is used by default. If printing problems occur (such as with the Evolis printer), select this option to use the Java Pageable printer interface.
<b>Rasterize before printing</b>	It converts the watermark into an image internally and prints it on the badge. <b>Note</b> Ensure that you do not enable this option unless there is an issue with printing the images on the badges.

**Step 6** Click **Save** to save the changes.



- Step 7** Log out and log back in to the ICPAM application to activate the changes (select Logout from the Options menu).

## Setting Up Image and Signature Options for Personnel Records

To add images and signatures to personnel records, enable the features as described in this section:

- [Enabling Image Capture Devices](#)
- [Enabling Signature Capture Devices](#)

### Enabling Image Capture Devices

ICPAM supports image capture from the following types of devices:

- Badging cameras which have a dedicated TWAIN driver
- Webcams which do not have a TWAIN driver.

Before proceeding to the steps below, install all necessary camera drivers including TWAIN drivers (if available). If you are unsure whether the camera uses a TWAIN driver, contact the camera manufacturer for assistance.

- Step 1** Select **Preferences** from the **Options** menu.
- Step 2** Select the **Image Capture** tab on the left of the **Preferences** window, as shown in [Figure 9-51](#).

*Figure 9-51 Preferences: Image Capture*

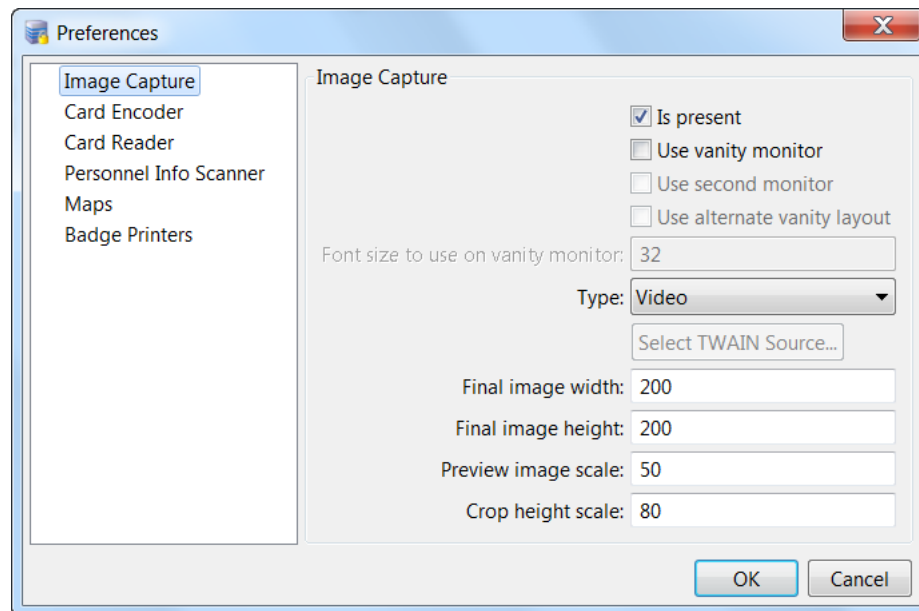

- Step 3** Check the **Is present** check box.

- Step 4** Select the image capture device type from the **Type:** drop-down menu. The options are:
- **Video.** Use this option in case of a non-TWAIN device like a normal webcam attached to the PC from which the client is run.
  - **TWAIN.** Use this option if the camera being used has a dedicated TWAIN driver.
- Step 5** Click the **Select TWAIN source from the list** button to open a source window. All selected drivers installed on the machine will be displayed. Select the correct driver and click the **OK** button.
- Step 6** If necessary modify the image width, height and scale of the capture device using the following settings.
- **Final image width:** The pixel width of the image capture.
  - **Final image height:** The pixel height of the image capture.
  - **Preview image scale:** The size of the image preview.
  - **Crop height scale:** It is recommended that the crop height and final image height are equal.
- Step 7** Click **OK** to save the settings.

The **Capture** button is activated in the Personnel module. See [Configuring Personnel, page 9-2](#) for more information. Click the **Capture** button and verify that the TWAIN driver is selected and opens properly.

---

## Enabling Signature Capture Devices

- Step 1** Select **System Configuration** from the **Admin** menu.
- Step 2** Select the **Data Entry/Validation - Personnel** tab at the left of the window, as shown in [Figure 9-52](#).

*Figure 9-52 System Configuration: Personnel*

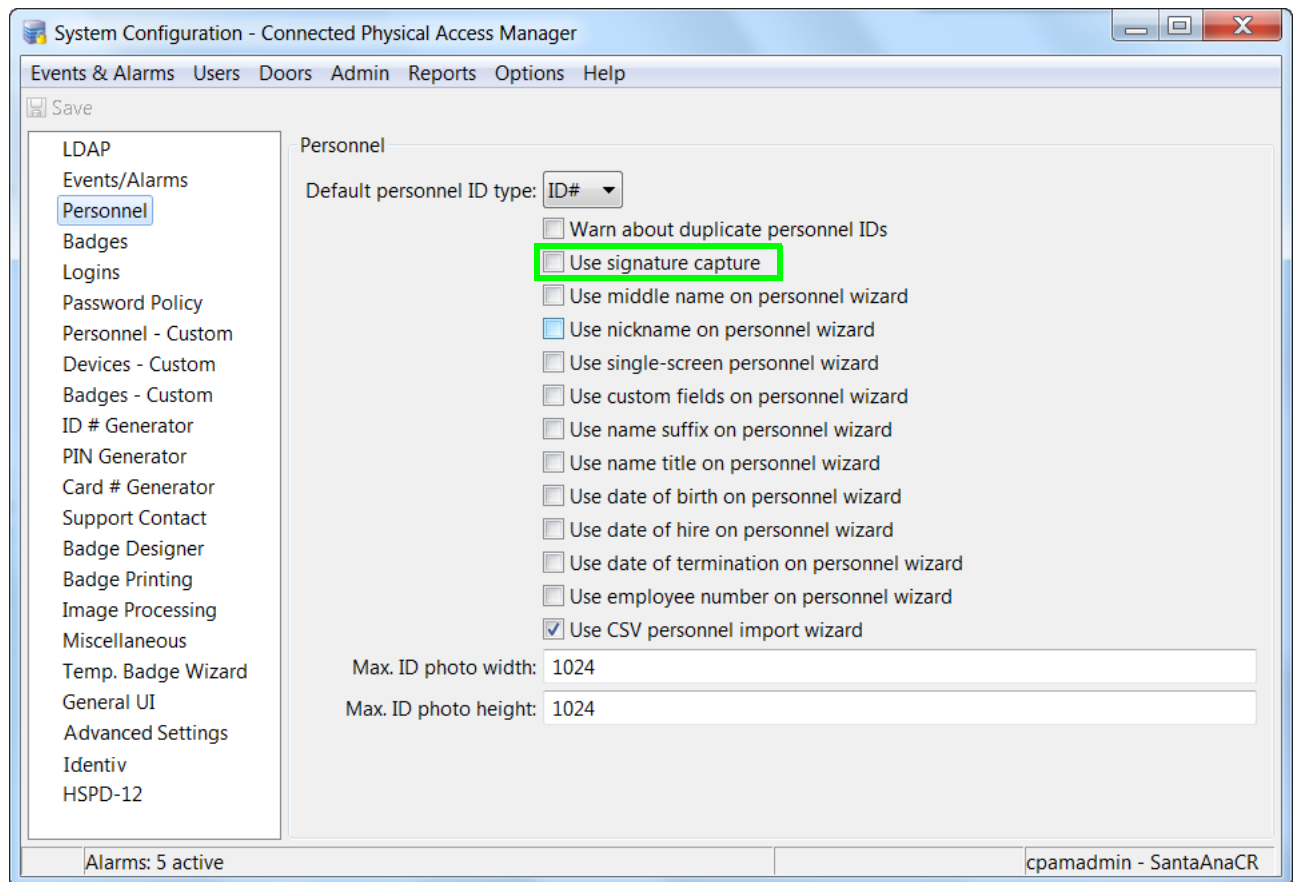

- Step 3** Check the **Use signature capture** box. Checking this box enables the signature capture capability in the **Personnel** module.
- Step 4** Click **Save** to save the changes.
- Step 5** Log out and log back in to the ICPAM application to activate the changes (select Logout from the Options menu).



**Note** You must log out and log back in for the Signature Capture menu to appear in the Preferences window.

- Step 6** Log in to the ICPAM application.
- Step 7** Select **Preferences** from the **Options** menu.

**Step 8** Select the **Signature Capture** tab on the left of the **Preferences** window, as shown in [Figure 9-53](#).

*Figure 9-53 Preferences: Signature Capture*

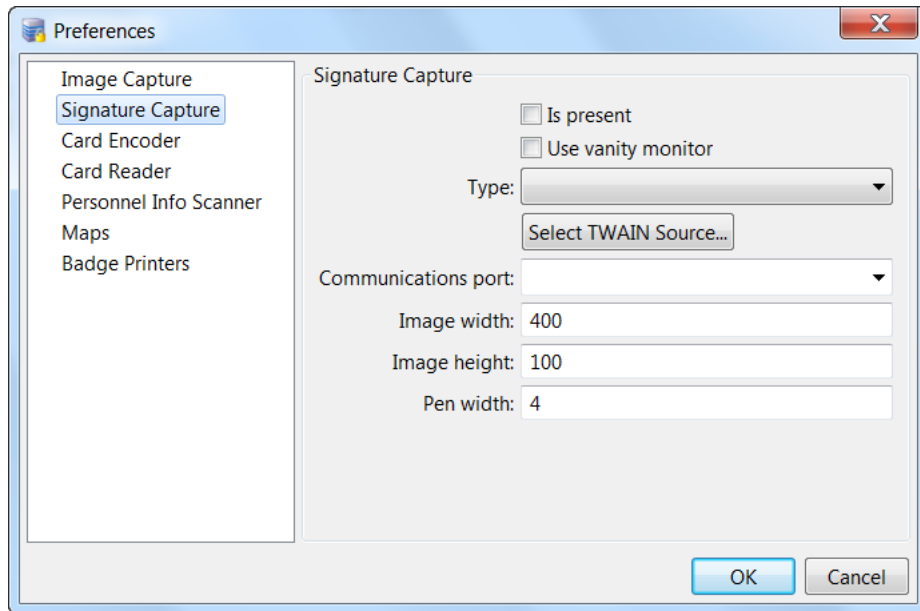

**Step 9** Check the **Is Present** check box, and select the **Type** of signature pad from the drop-down list.

**Step 10** Select the **Communications port** from the drop-down list.

**Step 11** Click **OK** to save the settings.

The signature detail in the Personnel module now includes an **Import** and **Capture** button. See [Configuring Personnel, page 9-2](#) for more information.

# Multifactor Authentication

You can integrate additional access control devices like biometric devices to ICPAM to increase security. These devices are configured as generic readers in the ICPAM server. The generic readers are associated with doors and finally configured to a specific controller. Once configured, the controller maps the data from the generic reader and matches it with the server. If matched, the events are triggered accordingly.

The generic readers are restricted by the location hierarchy when the hierarchical location is set in [Logins page of the System Configuration window, page 17-11](#).

### Contents

- [Configuring Generic Readers, page 10-1](#)
- [Associating Generic Readers with Doors, page 10-3](#)

## Configuring Generic Readers

To configure a generic reader, follow this procedure.

**Step 1** From the Doors menu, click **Generic Readers**.

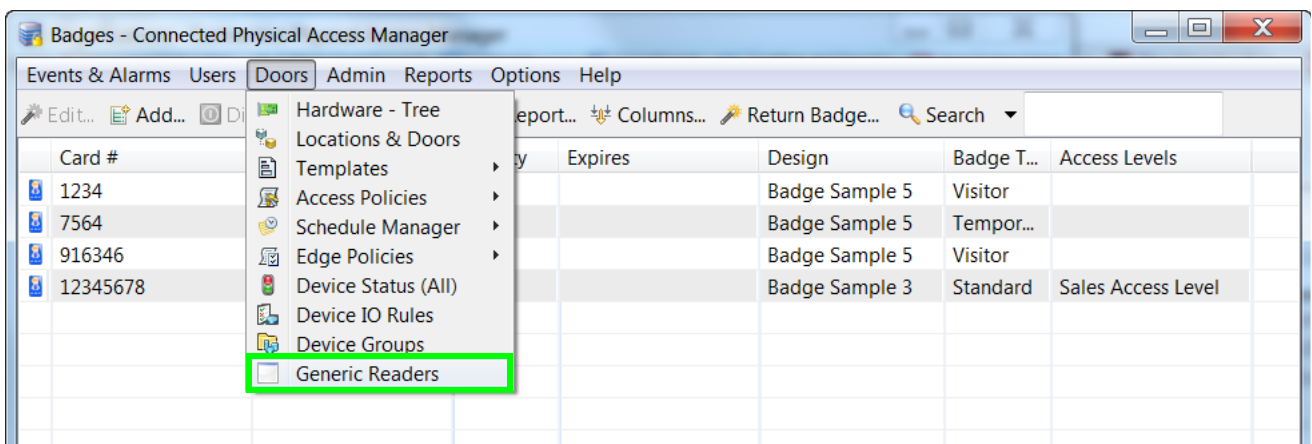

**Step 2** The Generic Reader window opens. Click **Add**.

Enter the following fields:

- Name (alpha-numeric characters)
- ID (numeric)

Select values from the following drop-down lists:

- Generic reader type



**Note** This option should be used when using Microsoft Active Directory. Two types of generic readers are configurable. These are face detection (used for facial recognition devices) and biometric (for all other devices like fingerprint readers).

- Generic reader category
- Hierarchical location

For the **ADA enabled** option, select the **Yes** radio button.



**Tip** Ensure that Name and ID are similar.

**Step 3** Click **Save and Close**. The Reader information is listed in the Generic Reader window.

Name	ID	Generic ...	Generic ...
Biometri...	34671	BIOMET...	ENTRY_...



**Note** Only users with Admin rights are permitted to configure generic readers.

# Associating Generic Readers with Doors

To associate a generic reader with a door, follow this procedure.

- Step 1** From the **Doors** menu, select **Hardware - Tree**. The controllers, gateway drivers, and doors are displayed.

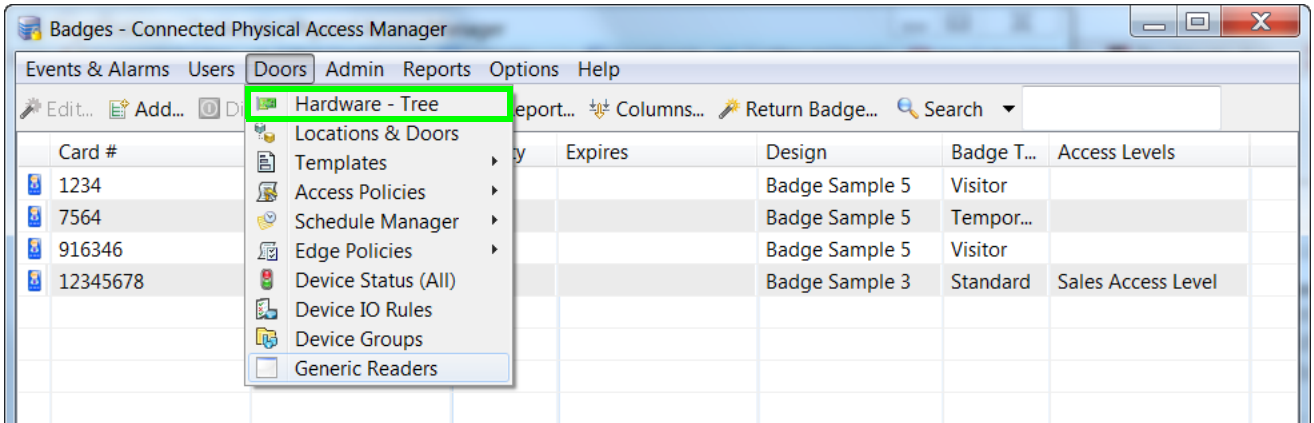

- Step 2** Select the door and right-click on it to view the pop-up menu. Click **Associate Generic Reader**. An Associate Generic reader window opens.

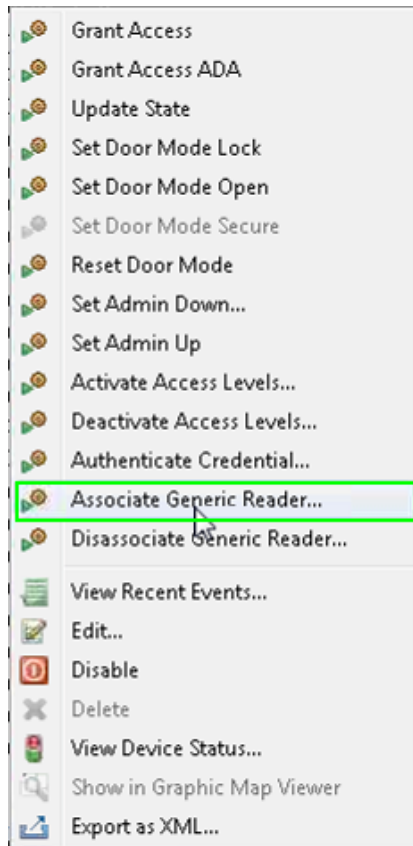

**Step 3** Select the generic reader from the list and click **OK**. The generic reader is configured to the door.

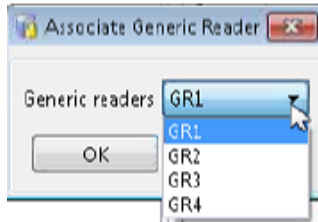

**Note** You can associate a maximum of six generic readers to a door.

**Step 4** Click **Disassociate Generic Reader** to remove a reader from the door configuration.

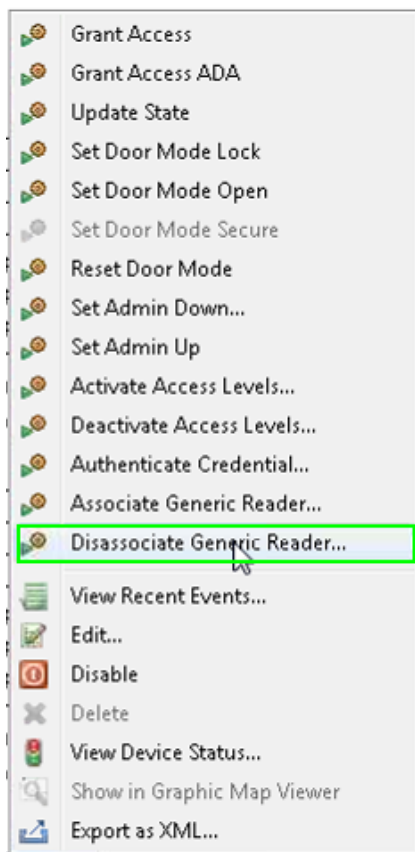

**Note** The right-click menu displays the list of generic readers assigned to the door.

**Step 5** Right-click on the door and select **Edit**. The Edit Door window opens.



- Step 6** In the resulting **Edit Door** window, select **Properties** to view the generic readers added to the door and the multifactor authentication timer (in seconds). You can edit the timer and set the time.

**Note** The default value of Multifactor Authentication timer (sec) is 10 seconds.

**Note**

- The generic readers configured by the cpadmin is not restricted to any hierarchical location.
- When a location-restricted user creates a generic reader, the hierarchical location field is auto-populated.
- The location-restricted users can access only devices (generic readers) of their location and the events for these devices alone is populated for them.

**Note**

These points are applicable only when the profile enhancement feature is set on the **Logins** page of the **System Configuration** window (starting with the ICPAM 2.1 release); otherwise, the ICPAM appliance retains its behavior as in the previous version (CPAM 1.5.1).

## Additional Information

Multifactor authentication depends on the external system to authenticate biometric or facial data that ICPAM receives from the generic reader. ICPAM does not claim support to authenticate the received data. The controller authenticates the data based on the badge swipe by the user and HTTPS MFA requests it receives from external devices configured as generic readers in ICPAM.

The external system must send the following HTTPS request for establishing a session with GW.

For example:

```
POST /fcgi/user.login?login HTTP/1.1
Accept: image/gif, image/x-xbitmap, image/jpeg, image/pjpeg, application/x-ms-application,
application/vnd.ms-xpsdocument, application/xaml+xml, application/x-ms-xbap,
application/vnd.ms-excel, application/vnd.ms-powerpoint, application/msword, */*
User-Agent: Mozilla/4.0 (compatible; MSIE 7.0; Windows NT 5.1; .NET CLR 1.1.4322; .NET CLR
2.0.50727)
Host: 10.78.179.95
Content-Length: 48
Content-Type: application/x-www-form-urlencoded
Accept-Language: en-au
Cache-Control: no-cache

username=gwadmin&password=Cisco123&TRACKID=12345
```

The external system after authenticating the biometric data must send the following HTTPS request to GW.

For example:

```
POST /fcgi/webmgr.ac?post_generic_rdr_event HTTP/1.1
Accept: image/gif, image/x-xbitmap, image/jpeg, image/pjpeg, application/x-ms-application,
application/vnd.ms-xpsdocument, application/xaml+xml, application/x-ms-xbap,
application/vnd.ms-excel, application/vnd.ms-powerpoint, application/msword, */*
User-Agent: Mozilla/4.0 (compatible; MSIE 7.0; Windows NT 5.1; .NET CLR 1.1.4322; .NET CLR
2.0.50727)
Host: 10.78.179.95
Content-Length: 59
Content-Type: application/x-www-form-urlencoded
Accept-Language: en-au
Cache-Control: no-cache

hibadge=0&lobadge=34959&Generic_Reader_id=GR1&TRACKID=12345
```

where:

TRACKID — user defined cookie

hibadgeq—higher 32 bits of a badge (supports a maximum of 64 bits)

lobadge—lower 32 bits of a badge

Generic\_Reader\_id—ID of the generic reader as configured under the Generic Reader Module.

## Configuring ICPAM Access Policies

---

This chapter describes how to create the ICPAM access policies assigned to badge holders that define which doors they can access, and the dates and times of that access. After being created, access policies are assigned to personnel badges.

In addition, you can create access policy schedules for doors that define when the doors are available.

### Contents

- [Configuring Access Policies, page 11-2](#)
- [Access Policies in ICPAM 2.1, page 11-5](#)
- [Managing Door Access With Access Policies, page 11-6](#)
- [Using the Schedule Manager, page 11-9](#)
  - [Schedule Manager in ICPAM 2.1, page 11-12](#)
- [Creating and Managing Anti-Passback Areas, page 11-19](#)
  - [Impact of the Profile Enhancement Feature on Anti-Passback Areas, page 11-20](#)
  - [Limitations of Anti-Passback Areas, page 11-21](#)
  - [Configuring Anti-Passback Areas, page 11-22](#)
  - [Using Local \(Controller\) Credentials if Network Communication is Lost, page 11-24](#)
  - [Evicting a Badge from APB if the User Does Not Enter the APB Area, page 11-26](#)
  - [Resetting the Status of All Card Holders \(at Online EM-100 Controllers\), page 11-29](#)
  - [Monitoring Anti-Passback Events, page 11-30](#)
  - [Anti-Passback Events Displayed in the Events Module, page 11-31](#)
- [Two-Door Policies, page 11-31](#)
  - [Two-Door Policies in ICPAM 2.1, page 11-31](#)
- [Two-Door State Monitoring, page 11-34](#)

# Configuring Access Policies

This section describes how to create an access policy and assign it to a user badge.

- Step 1** Select **Access Policy** from the Doors menu, under the **Access Policies** submenu.

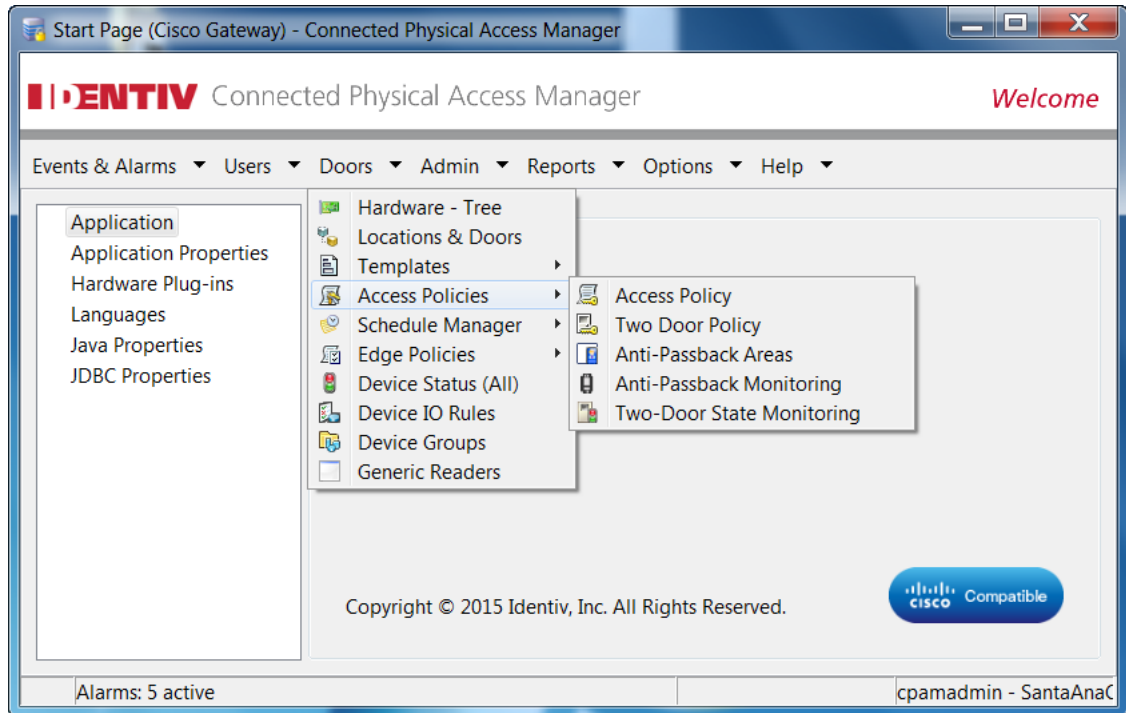

- Step 2** Click **Add**, or select an existing entry and click **Edit**.

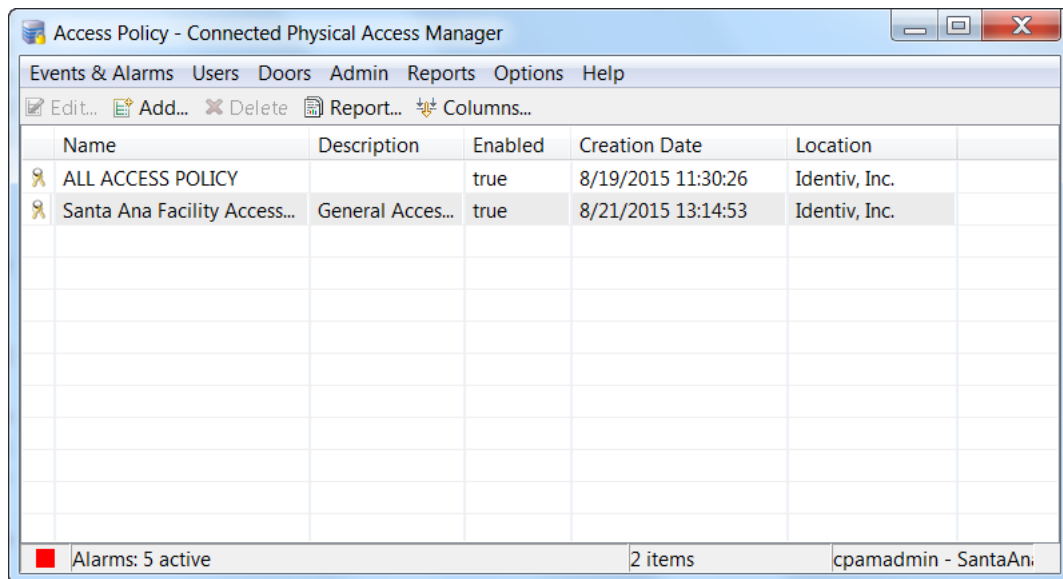

**Tip**

To remove a policy, highlight the entry and click **Delete**. Access policies cannot be deleted if they are assigned to one or more badges. Remove the policy assignment from all badges, and then delete the policy.

- Step 3** Enter the general information for the policy:
- Name:** Enter a descriptive name for the policy.
  - Hierarchical location:** Select the location.
  - Description:** Enter a description of the purpose or usage of the policy.
  - Enabled:** Select the check box to enable or disable the policy. The policy is enabled by default. If disabled, the policy can be assigned to users, but will not impact the users' access privileges.

The screenshot shows the 'Add - Access Level' dialog box. The 'Access Point Groups' tab is selected. The 'Name' field contains 'New Access Level'. The 'Enabled' checkbox is checked. The 'Location' dropdown is empty. The 'Access points' tree view shows a folder named 'TestingSite' containing two items: 'Door1' and 'Door2'. The 'Access point/schedule pairs' table is empty.

- Step 4** Add or remove sets of door and schedule settings for the access policy.
- Select a door or door group from the list box on the left. You can change the doors listed using the following controls:
    - Search Door List:** Search for a specific door using one or more keywords.
    - Door/Door Group:** Select an option to display single doors or door groups in the list view.
      - See [Chapter 7, “Configuring Doors”](#) to add doors.
      - Door Groups allow you to create groups of doors, such as all lobby doors. See [Configuring Device Groups, page 7-24](#).
  - Select a **Schedule**. To create a new schedule, click the **New Schedule** button. See [Using the Schedule Manager, page 11-9](#) for information.

- c. Repeat these steps to add or remove doors or schedules for the access policy.
- d. Verify that the correct doors and schedules appear in the list box on the right: **Door/Door Group** and **Schedule Pairs**.

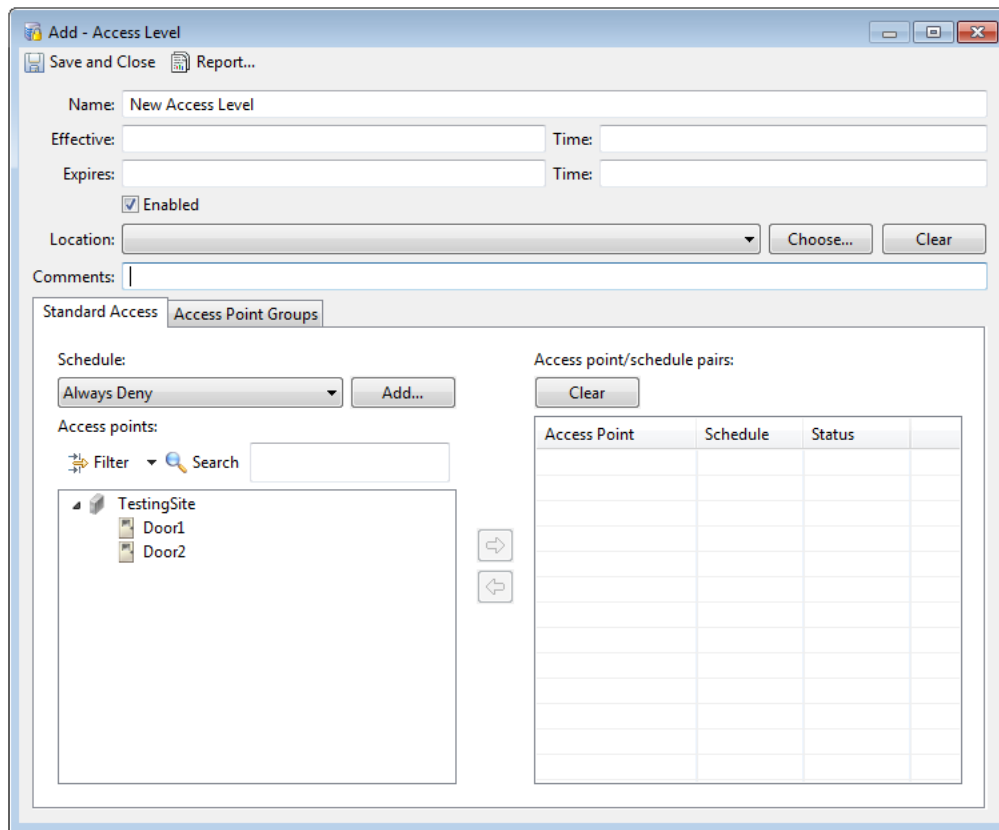

**Step 5** Click **Save and Close** to save the access policy.

**Step 6** Assign the access policy to one or more user badges:

- a. Open the **Personnel** module from the **Users** menu.
- b. Click **Add**, or select an existing personnel entry and click **Edit**.
- c. Select the **Badges** submenu.
- d. Click **Add**, or select an existing badge entry and click **Edit**.
- e. Select **Access Policies** (in the Badge window).
- f. Select the door access policies for the user badge.
- g. Click **Save and Close** to close the Badge window.

- h. Click **Save and Close** to close the personnel record.

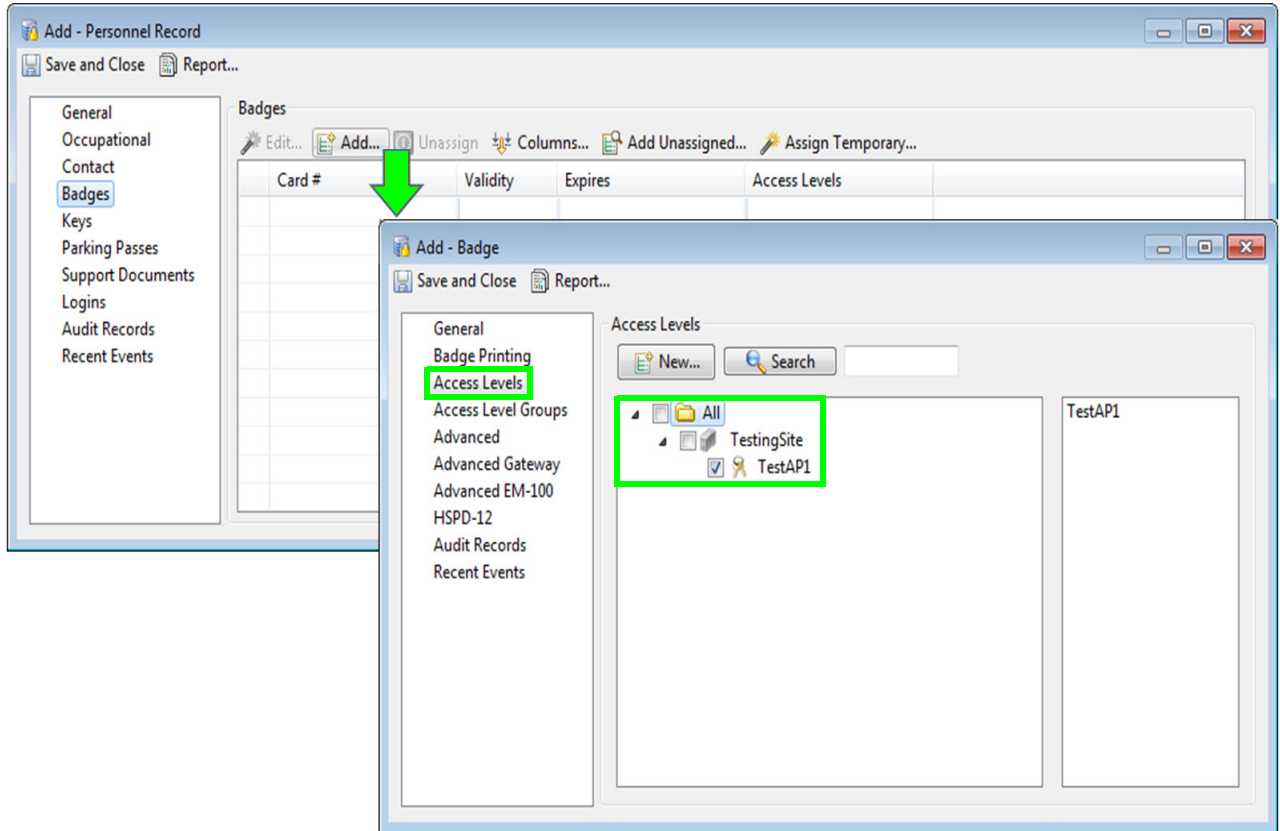

Tip

See [Chapter 9, “Configuring Personnel and Badges”](#) for more information.

## Access Policies in ICPAM 2.1

If the profile enhancement feature is set in the system configuration settings ([Logins page of the System Configuration window, page 17-11](#)), the following changes are impacted in this module:

- The location-restricted user can view only doors/door groups of their assigned location. They are allowed to create access policies only with these listed doors/door groups.
- The location-restricted user can re-use the access policies created up to the root level of the location hierarchy.
- The cpamadmin can view/edit/use the access policies created by the location-restricted users.

The number of access policies available is dependent on the type of controller:

- A Cisco gateway controller supports up to 50 access policies
- An Identiv EM-100 controller supports up to 8 access policies



Note

By default, the cpamadmin can view all doors in ‘Add Policy’ page because their login is not restricted by hierarchical locations.

- The **Name** field on the Add Policy page is a mandatory field while creating an access policy.
- When a location-restricted user logs in, the **Schedule** field displays the following details:
  - The schedules created by the profile user
  - The schedules created by cpamadmin
  - The schedules created (by other location-restricted users) up to the root level of the logged in user’s location
- The door groups of the location-restricted user’s location alone are displayed in ‘Add Policy’ page.



Note

These points are applicable only when the profile enhancement feature is set on the **Logins** page of the **System Configuration** window (starting with the ICPAM 2.1 release); otherwise, the ICPAM appliance retains its behavior as in the previous version (CPAM 1.5.1).

## Managing Door Access With Access Policies

Access policies can be deactivated and activated manually for one or more doors. For example, if you create three access policies for lobby doors (one for employees, a second for contractors, and a third for visitors), you can selectively deactivate the access policy for contractors on the main lobby door, or on all doors.

Access policies remain deactivated until one of the following events occur:

*Table 11-1 Reactivating Access Policies*

Command or action	Description
<b>Activate Access Policy</b>	Right-click a door and select the <b>Activate Access Policy</b> activate a policy and select <b>Deactivate Access Policy</b> to deactivate the access policy.
<b>Reset Gateway</b>	Right-click a gateway icon and select the <b>Reset Gateway</b> command to perform a soft reset of the controller. Access policies are activated during a soft reset.
<b>Reload Gateway Configuration</b>	Right-click a Gateway icon and select the <b>Reload Gateway Configuration</b> command to replace the existing controller configuration with a new copy. Access policies are activated during this process.
<b>Power cycle the Gateway module</b>	Access policies are activated whenever a controller is powered up. For example, after a power failure or anytime power is disconnected and restored.



**Procedure:**

Complete the following instructions to deactivate and reactivate door access policies.

- Step 1** View the status of the access policies on a door:
- Select **Hardware - Tree** or **Door/Location-based Hardware** from the **Doors** menu.
  - Click the door to highlight it.
  - In the Extended Status field, click the **Access Policies** tab to view the policies and status for the door.
- Step 2** To manually deactivate a policy, right-click the door icon and select **Deactivate Access Policies**.

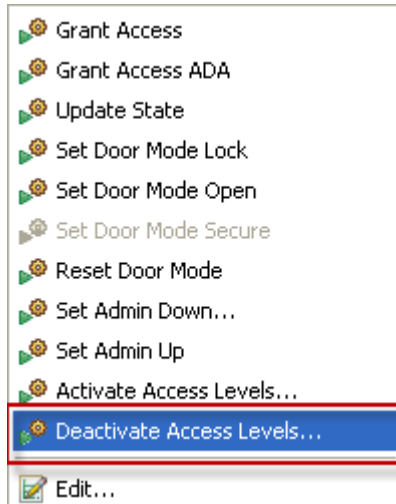

**Tip** To deactivate access policies for multiple doors, select the command from a location (Door/Location-based Hardware module) or from the Physical Driver (Hardware - Tree module).

- Step 3** Select the access policies to deactivate and click **OK**.

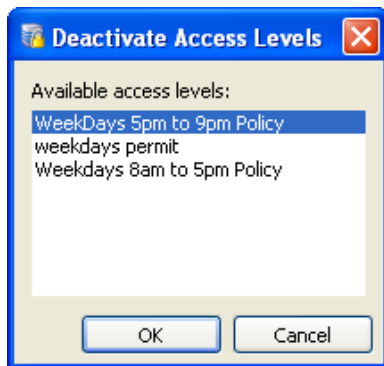

**Tip** Use Shift-click or Ctrl-click to select multiple items from the list.

- Step 4** Verify that the status of the access policy is **No**:
- Click the door to highlight it. This also refreshes the Extended Status data.
  - In the Extended Status field, click the **Access Policies** tab.
  - Confirm that the access policy is **No**.
- Step 5** To reactivate the access policy, right-click the door icon and select **Activate Access Policies**. Select one or more levels from the list and click **OK**.

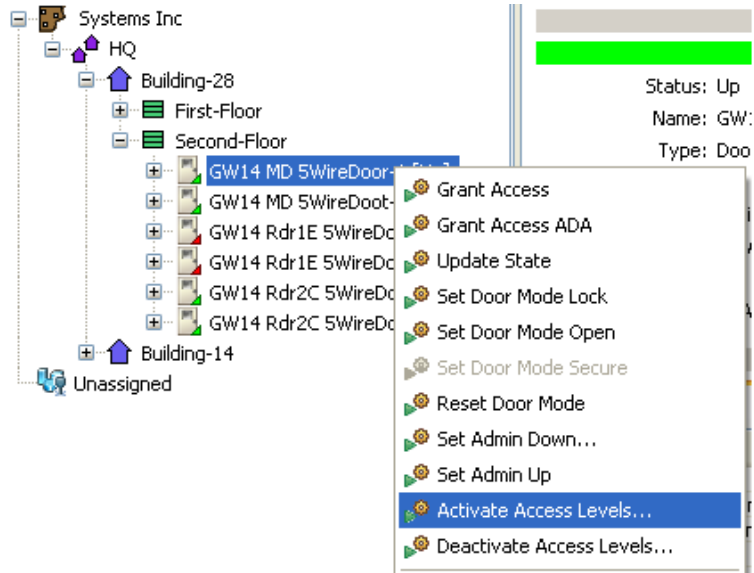

**Note** Access policies remain deactivated until manually reactivated using this command. See [Table 11-1 on page 11-6](#) for other methods to reactivate access policies.

# Using the Schedule Manager

The Schedule Manager defines schedules for users and doors, including the following:

- Access Policy schedules determine when a badge can be used to access doors. For example, you can create a basic access policy schedule for the weekdays, an additional schedule for the weekend, and a third that denies access for specified holidays when the building is closed. See [Configuring Access Policies, page 11-2](#) for more information.
- Door schedules are used in door configurations to define the state of the door based on the time and day. For example, each door configuration has a default mode that defines if the door is locked, unlocked, secured, or left open. The door remains in this mode at all times unless you configure an optional schedule to define exceptions to the default mode. For example, if the default mode for a door is Lock, and you define a door schedule that automatically unlocks the door between 8 am and 5 pm. (Close), then the door will be locked at all hours except 8 am to 5 pm. See the [“Understanding Door Modes, Door Schedules, and the First Unlock Feature”](#) section on page 5-28 and the [“Adding New Doors”](#) section on page 7-2 for more information.

To add or edit schedules, do the following:

**Step 1** Select **Schedules** from the **Doors** menu, in the Schedule Manager submenu.

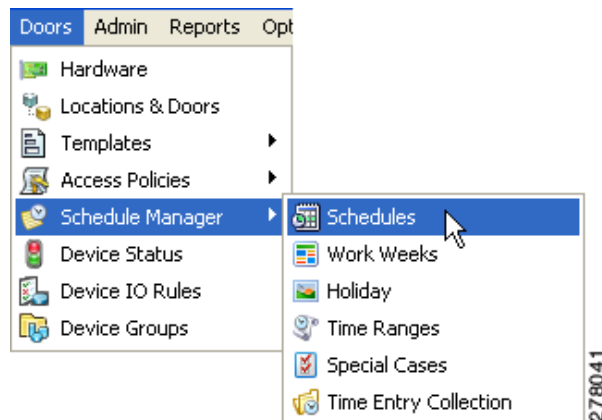

**Step 2** Click **Add**, or select an existing entry and click **Edit**.

To remove a schedule, highlight the entry and click **Delete**.

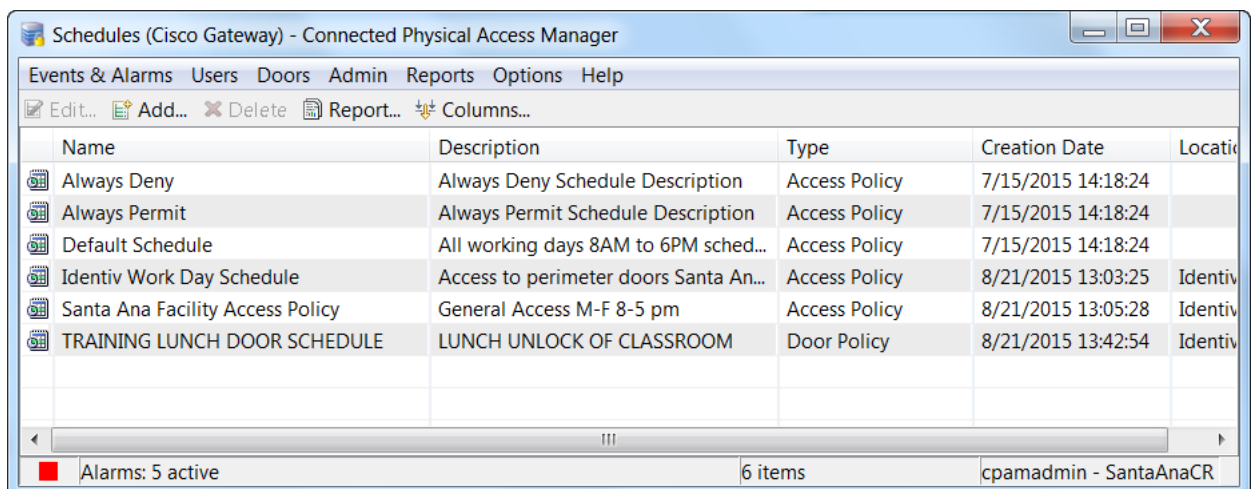

**Note** Schedules cannot be deleted if they are assigned to one or more access policies. To delete schedule that is assigned to an access policy, you must first remove the schedule assignment from all access policies.

**Step 3** Enter the Name, hierarchical Location, and description for the schedule.

**Step 4** Select a **Schedule Type**:

- **Door Policy**: door schedules appear in the door properties window under the menu: **Door enable schedule**. See Step 4. on page 8-5 in [Configuring Door Templates](#) for more information.
- **Access Policy**: access policy schedules define the schedule for user badge access. See [Configuring Access Policies, page 11-2](#) for more information.

**Step 5** Select the **Type**, and then select an existing **Value**.

To create or modify the available values, see [Modifying Types and Time Ranges, page 11-13](#).

- Select **Holiday** to define a single date, or range of consecutive dates.
- Select **Work Weeks** to define the days of the week for a schedule.
- Select **Special Cases** to define a schedule for a date or range of dates that repeat on a regular schedule. For example, the first Monday in each month.
- The **Time Entry Collection** allows you to reuse Holiday, Work Weeks, or Special Case schedules.

**Note** A Time Entry Collection can be used in more than one schedule, but only if the schedules have the same action (such as Allow or Deny). If a Time Entry Collection is assigned to schedules with different actions, then the schedule operation will be inconsistent.

**Step 6** Select an **Action**:

- Access Policy schedules: select **Deny** or **Permit** to define if the user should have access during the defined schedule.
- Door schedules: select **Use Schedule Mode**.

**Note** The **Default Mode** option enables the default door mode defined in the door Properties window. See Usage Note 4. on page 8-5 in [Configuring Door Templates](#) for more information.

**Step 7** Select a **Time Range** for the schedule.

To create or modify the available values, see [Time Ranges](#), page 11-16.

**Step 8** Click **Add** to add the entry to the list of defined schedules.

The screenshot shows the 'Add Schedules' dialog box. The fields are filled with the following information:

- Name: Week Days Only
- Schedule type: Access Policy
- Hierarchical location: Miplaza/Campus
- Description: Schedule for Monday through Friday
- Type: Week Groups
- Values: Week Days
- Action: Permit
- Time range: Always Time Range Group

The 'Add' button is highlighted with a green box. Below the form is a table with the following data:

Type	Values	Time Ranges	Action
Week Groups	Week Days	Always Time Range Group	Permit

a. Repeat [Step 5 to a.](#) to add additional schedules, if necessary.

b. Click **Save and Close**.

**Step 9** To apply schedules to an access policy, see [Configuring Access Policies](#), page 11-2.

To apply a schedule to a door configuration, see [Configuring Door Templates](#), page 8-2 and [Adding New Doors](#), page 7-2. Door schedules are selected in the Properties window under the **Use Schedule Mode** menu.

## Schedule Manager in ICPAM 2.1

If the profile enhancement feature is set in the system configuration settings ([Logins page of the System Configuration window, page 17-11](#)), the following changes are impacted in this module:

- The schedules can be added by users only for locations or sub-locations assigned to their user profile.
- The Time entry collections and Time ranges available for selection within a schedule is also based on the user's hierarchical location. Consequently, the time entry collections and time ranges of other locations are not valid.
- The location-restricted users have read-write access to schedules in the sub-tree of their location and read-only access to schedules in the ancestral path.

**Figure 11-1** Schedule based in Hierarchical location

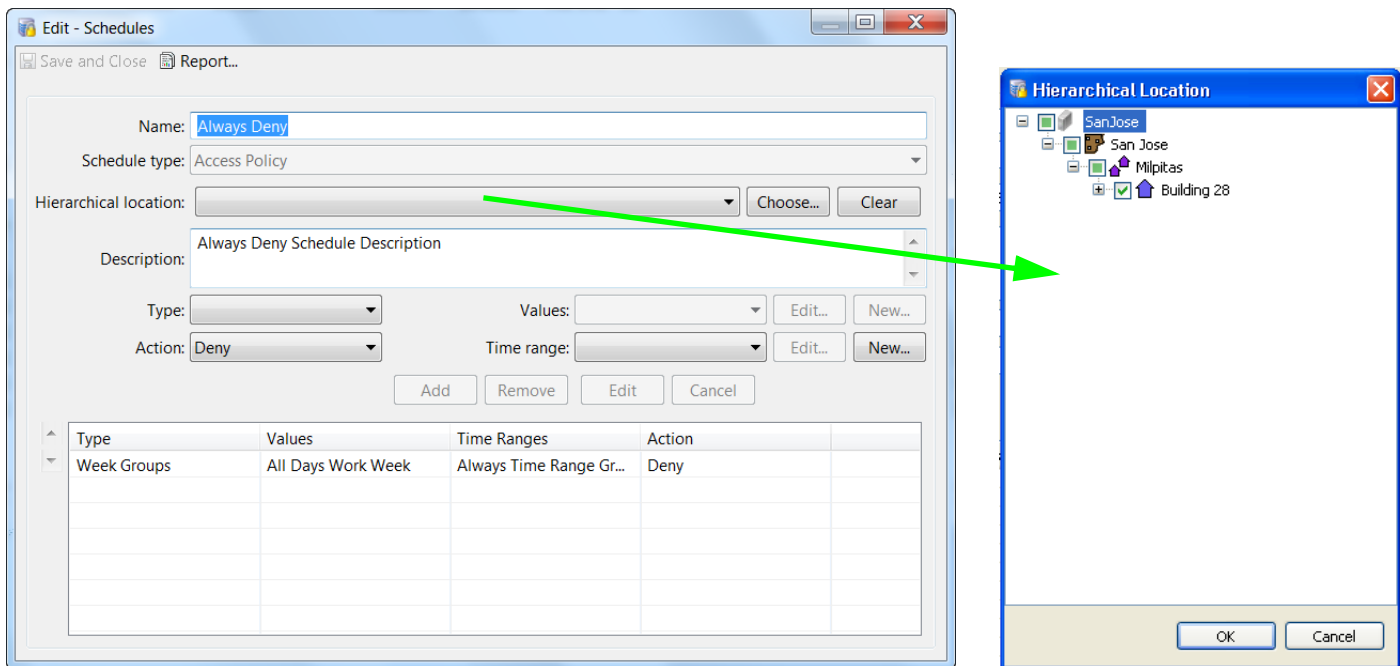

- When a location-restricted user logs in the 'Add Schedule' page, the **Hierarchical Location** field (by default, takes the location of the logged in user) is auto-populated.
- The location-restricted user can reuse all schedules created by the cpadmin and other profile users up to the root level of the current logged in profile user. (This includes the location-restricted user's own schedules too.)
- The location-restricted users cannot view any unprivileged child schedules in/below their location.



### Tip

If the cpadmin assigns a door policy from an unprivileged location to the logged in location-restricted user, the policy continues to work but it is not auto-populated to the logged in location-restricted user. This observation is seen across all modules. Hence it is recommended to use legitimate policies for seamless working of the profile enhancement feature.

**Note**

These points are applicable only when the profile enhancement feature is set on the **Logins** page of the **System Configuration** window (starting with the ICPAM 2.1 release); otherwise, the ICPAM appliance retains its behavior as in the previous version (CPAM 1.5.1).

## Modifying Types and Time Ranges

The values for **Type** can be modified in the schedule window, or by selecting the item from the Doors menu, under the Schedule Manager submenu (Figure 11-2).

Figure 11-2 Schedule Manager Submenu

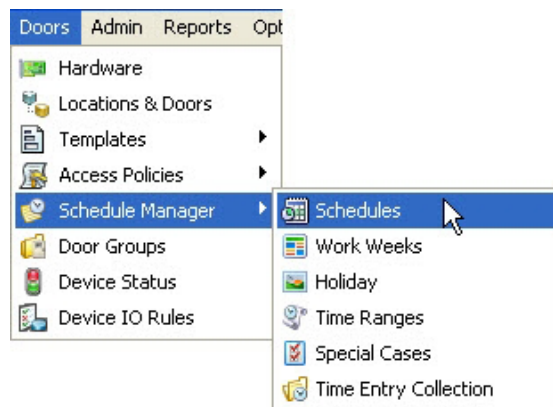

The items in the Schedule Manager only define the available work weeks, holidays, time ranges, special cases, and Time Entry Collections. You must still assign these values to a schedule. After the schedule has been defined, assign the schedule to an access policy or to a door configuration. See [Using the Schedule Manager, page 11-9](#) for more information.

**Note**

If the profile enhancement feature is set in the system configuration settings, then the location-restricted user can reuse all Schedules, Work weeks, Holidays, Time ranges, and Special cases created by the cpadmin and other location-restricted users up to the root level of the current logged in location-restricted user.

Follow the steps below to modify Work Weeks/Holidays/Time Ranges/Special Cases/Time Entry Collections:

- [Modifying Work Weeks, page 11-14](#)
- [Modifying Holidays, page 11-15](#)
- [Time Ranges, page 11-16](#)
- [Modifying Special Cases, page 11-17](#)
- [Time Entry Collections, page 11-18](#)

## Modifying Work Weeks

**Work weeks** define the days of the week for a schedule.

To edit one or more work weeks:

- 
- Step 1** Select **Work Weeks** from the Doors menu, under the Schedule Manager submenu.
- Step 2** Click **Add**, or select an existing entry and click **Edit**.
- Step 3** In the resulting **Edit Work Week** dialog:

- a. Enter the name of the value.
  - b. Enter a short text description.
  - c. Select the hierarchical location.
  - d. Select the days to include in the work week. For example, select Monday through Friday to define a work week for the weekdays, or select Saturday and Sunday to define a value for the weekend.
  - e. When you are done, click **Save and Close**.
- 



### Note

Work Weeks can be added by users only for locations or sublocations assigned to their user profile. This is based on system configuration settings. See [Logins page of the System Configuration window, page 17-11](#).

---



## Modifying Holidays

**Holiday** defines a single date, or a range of consecutive dates.

To modify one or more holiday dates:

- Step 1** Select **Holiday** from the Doors menu, under the Schedule Manager submenu.
- Step 2** Click **Add**, or select an existing entry and click **Edit**.
- Step 3** For example, on the resulting **Add Holiday** dialog:

- a. Type the **Name** of the holiday.
- b. Type a short text **Description** of the holiday.
- c. Select the **Hierarchical location**.
- d. To specify a **Start date** and an **End date** for the holiday, click in each date field to open a calendar, navigate to the desired date, and then double-click on that date.
  - For a holiday that is one day, select the same day for both the beginning and end dates.
  - To reset the calendar to the current date, click the **Today** button.
- e. When you are done, click **Save and Close**.



### Note

Holidays can be added by users only for locations or sublocations assigned to their user profile. This is based on system configuration settings. For more information, see [Logins page of the System Configuration window, page 17-11](#).

## Time Ranges

Time Ranges specify the time span for a schedule type.

To define a time range:

- Step 1** Select **Time Range** from the Doors menu, under the Schedule Manager submenu.
- Step 2** Click **Add**, or select an existing entry and click **Edit**.
- Step 3** For example, on the resulting **Edit Time Ranges** dialog:

- a. Type the **Name** of the time range.
- b. Select the **Hierarchical location**.
- c. Type a short text **Description**.
- d. Specify a **Start time** and an **End time** in 24-hour format. For example, enter 13:00 for 1 p.m.
- e. Click **Add** to add a time range to the **Start Time - End Time** list.
  - You can add multiple time ranges to a single entry.
  - To remove a time range, click on it, and then click **Remove**.
- f. When you are done, click **Save and Close**.



### Note

Time Ranges can be added by users only for locations or sublocations assigned to their user profile. This is based on system configuration settings. For more information, see [Logins page of the System Configuration window, page 17-11](#).

## Modifying Special Cases

Select **Special Cases** to define a schedule for a date or range of dates that repeat on a regular schedule. For example, you can create a special case for the first Monday in each month. Select an existing Special Case from the **Value** drop-down menu, or do the following.

- 
- Step 1** Select **Special Cases** from the **Doors** menu, under the **Schedule Manager** submenu.
- Step 2** Click **Add**, or select an existing entry and click **Edit**.
- Step 3** For example, on the resulting **Add Special Case** dialog:

- a. Type the **Name** of the special case.
  - b. Type a short text **Description**.
  - c. Select the **Hierarchical location**.
  - d. Specify the **Recurrence** frequency. For example, Every Year.
  - e. Select a **Day of year** or a **Month** for the recurring schedule. If you select Month, either select a specific month for the schedule, or select **Every Month**.
  - f. Specify the options for either **Week** or **Day of month**.
  - g. When you are done, click **Save and Close**.
- 



### Note

Special Cases can be added by users only for locations or sublocations assigned to their user profile. This is based on system configuration settings. For more information, see [Logins page of the System Configuration window, page 17-11](#).

---

## Time Entry Collections

Time Entry Collections enable you to create groups of other schedule types, including holidays, work weeks, or special case schedules. For example, you can define individual holidays and then group all the holidays on the calendar as a `timeEntryCollection - US Holidays Calendar`. This can then be used in a schedule entry with “Permit” or “Deny”.



### Note

A Time Entry Collection can be used in more than one schedule only if the schedules have the same action (such as Allow or Deny). If a Time Entry Collection is assigned to schedules with different actions, then the schedule operation will be inconsistent.

- Step 1** Select **Time Entry Collection** from the Doors menu, under the Schedule Manager submenu.
- Step 2** Click **Add**, or select an existing entry and click **Edit**.
- Step 3** For example, on the resulting **Add Time Entry Collection** dialog:

Type	Values	Time Ranges

- a. Type the **Name** of the time entry collection.
- b. Select the **Hierarchical location**.
- c. Type a short text **Description**.
- d. Select the **Type**. For example, Holiday, Work Week, or Special Case.
- e. Select a **Value** for the selected Type. For example, if you selected the Type of **Holiday**, you might select Christmas. To create a new value, click **New** to open an Add dialog.
- f. Select a **Time Range**.
  - For example, **Default Time Range Group**.

- To create a new time range, click **New** to open an Add dialog.
  - If you selected Month, either select a specific month for the schedule, or select **Every Month**.
- g. Click **Add** to add the entry.
  - h. Repeat the previous steps to add more items to this time entry collection.
  - i. When you are done, click **Save and Close**.

**Note**

Time Entry collections can be added by users only for locations or sublocations assigned to their user profile. This is based on system configuration settings. For more information, see [Logins page of the System Configuration window, page 17-11](#).

## Creating and Managing Anti-Passback Areas

An anti-passback area is a secure area where you want to prevent someone from badging in and then passing their badge back to another person, who can use it again to gain access to that area. To create an anti-passback area, configure a door with two readers: one as an entry reader (to gain entry into the anti-passback area), and one as an exit reader (to leave the anti-passback area). After a badge is inside an anti-passback area, it must be used to exit that area before it can be used to enter the area again.

Anti-passback provides a higher level of security by recording and controlling badge holder exit points as well as entry points. Anti-passback areas provide the following controls:

- Records a badge holder's entry and exit through a door or set of doors.
- Requires that the badge holder exit through a specified door or set of doors.
- Prevents a badge holder from entering a door and then passing their badge to another person to enter the same door.

The consequences of violating the anti-passback conditions vary depending on the anti-passback mode configured for a specific access point.

Defining multiple anti-passback area can be complicated, especially when the areas are adjacent or when your ICPAM system uses a mixture of Cisco Gateway and Identiv EM-100 controllers.

### Related Documentation

See the following sections for more information:

- [Impact of the Profile Enhancement Feature on Anti-Passback Areas, page 11-20](#)
- [Limitations of Anti-Passback Areas, page 11-21](#)
- [Configuring Anti-Passback Areas, page 11-22](#)
- [Using Local \(Controller\) Credentials if Network Communication is Lost, page 11-24](#)
- [Evicting a Badge from APB if the User Does Not Enter the APB Area, page 11-26](#)
- [Resetting the Status of All Card Holders \(at Online EM-100 Controllers\), page 11-29](#)
- [Monitoring Anti-Passback Events, page 11-30](#)
- [Anti-Passback Events Displayed in the Events Module, page 11-31](#)

## Impact of the Profile Enhancement Feature on Anti-Passback Areas

Starting with ICPAM 2.1, if the profile enhancement feature for associating a user profile with a location is set in the system configuration settings (see [Logins page of the System Configuration window, page 17-11](#)), the anti-passback areas are impacted in the following ways:

- The user can create anti-passback areas for doors assigned to their hierarchical location only. The doors of other locations are not displayed. For example, if a user profile is assigned to location ‘San Jose’ the doors associated with that location alone are displayed. If the user wants to view all doors, then the system configuration settings should be set accordingly as shown in [Figure 11-3](#).

*Figure 11-3 Login page of System Configuration window, with settings so user profiles are not restricted by locations*

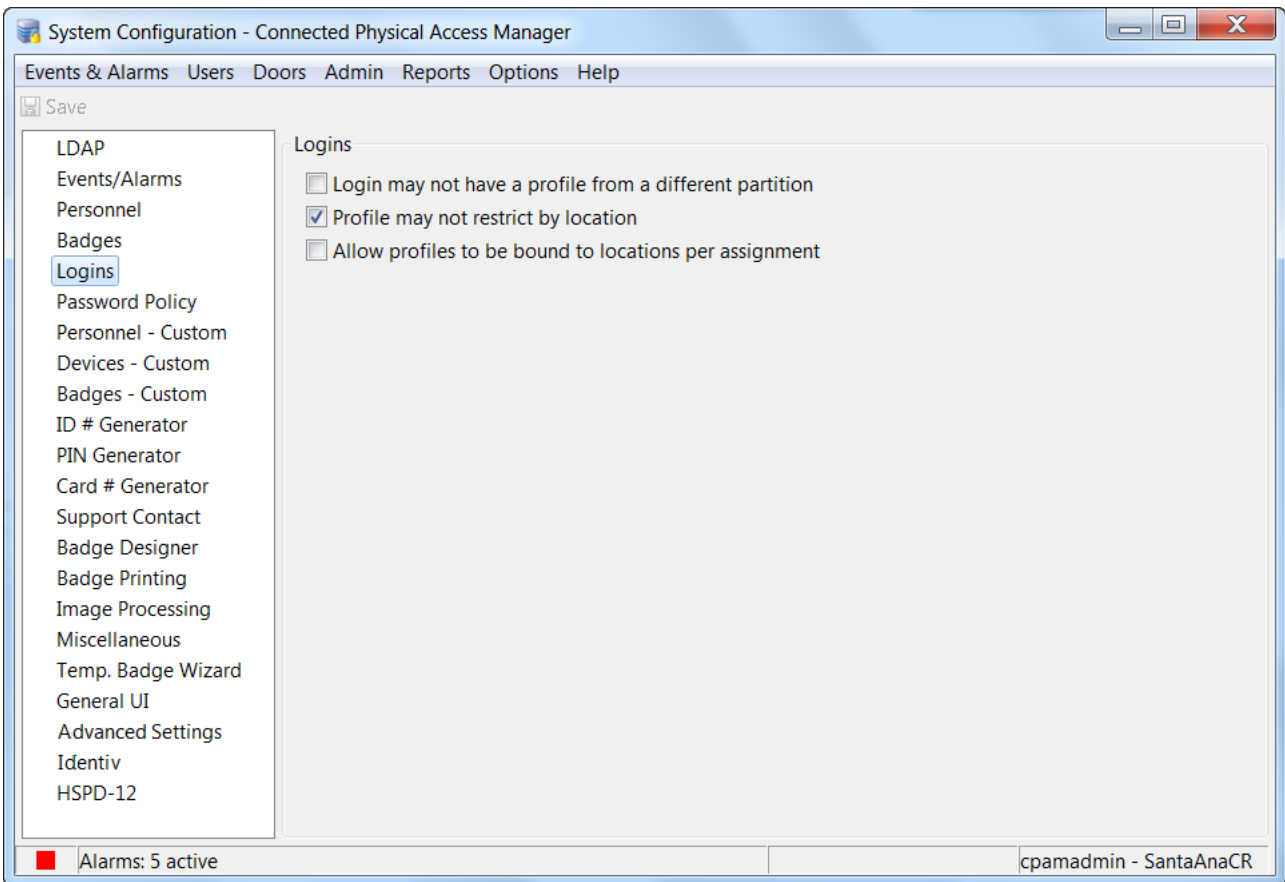

- The hierarchical location is auto-populated for a user profile when a new APB policy is created.
- When a location-restricted user selects the doors for an APB policy, only doors within the user’s location are listed for selection.
- The cpamadmin must assign appropriate locations for the APB area and its corresponding doors with that of the logged in user for the existing APB areas to avoid any behavior discrepancy.
- The **Anti-Passback Monitoring** window displays all badges, but the location-restricted user can reset badges related only to the user’s location.

**Tip**

While configuring an APB policy, it is required to have all the entities that is the policy location and the door in the policy to the location of the logged in user.

**Note**

These points are applicable only when the profile enhancement feature is set on the **Logins** page of the **System Configuration** window of ICPAM; otherwise, the ICPAM appliance retains its behavior as in the previous version (CPAM 1.5.1).

## Limitations of Anti-Passback Areas

When designing the anti-passback areas for your ICPAM system, be aware of the following limitations or requirements:

- To use an EM-100 controller with ICPAM's anti-passback feature, it must have an optional Exit Reader Expansion Module.
- Cisco Gateway controllers and EM-100 controllers cannot be used together within a particular anti-passback area. An anti-passback area can use either Cisco Gateway controllers or EM-100 controllers, but not both.
- An EM-100 controller can be configured with only one **Anti-passback mode**, so adjacent anti-passback areas using EM-100 controllers cannot have different anti-passback modes.
- The **Soft Timed (Grant Access)** anti-passback mode is available only for EM-100 controllers.
- A door can only be assigned to the entry of one anti-passback area, and to the exit of one anti-passback area. (It cannot be the entry of two different anti-passback areas, or the exit of two different anti-passback areas.)
- A door can participate in multiple anti-passback areas only when: each area has the same anti-passback mode, and the door has a different purpose (entry versus exit) in each area.
- A set of EM-100 controllers with static IP addresses can manage some of the details for a particular anti-passback area (without involving the ICPAM Server), if the necessary network communication services and ports are properly configured. For more information, see “Default Services and Ports for the EM-100 Controller” in the *ICPAM Installation Guide*.
- An anti-passback area that uses EM-100 controllers should have a maximum of four controllers.

## Configuring Anti-Passback Areas

To create or modify an anti-passback area, perform the following steps.

**Step 1** Select the **Doors > Access Policies > Anti-Passback Areas** command.

As shown in [Figure 11-4](#), the left pane of the resulting **Anti-Passback Areas** window shows all of the available doors (for both Cisco Gateway controllers and Identiv EM-100 controllers), and the table in the right pane lists the currently defined anti-passback areas.

*Figure 11-4 Anti-Passback Areas main window*

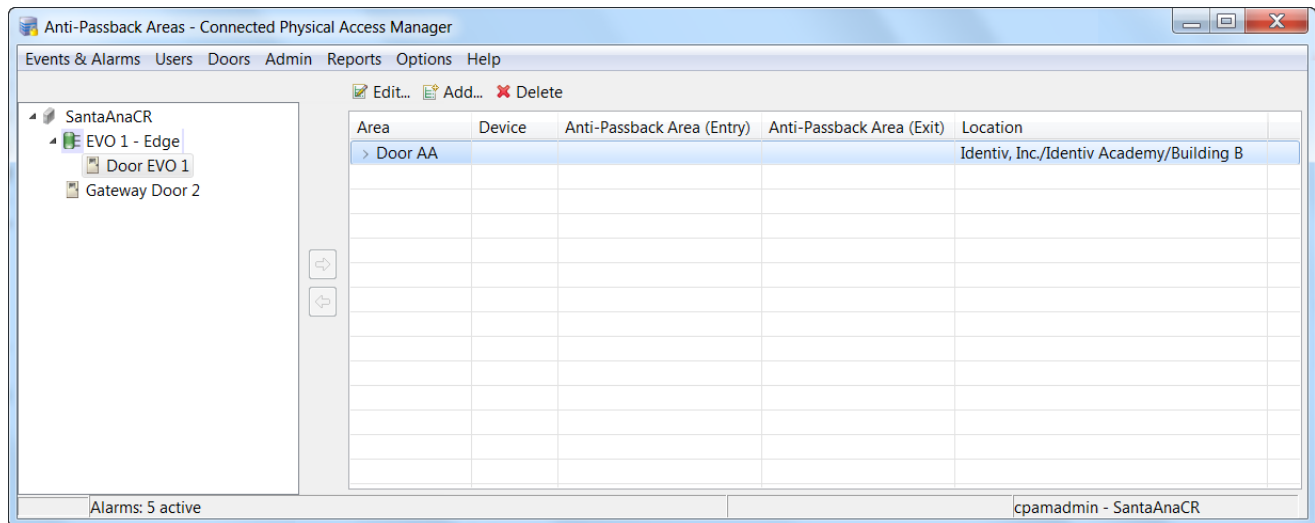

The toolbar above the table has buttons which enable you to manage the anti-passback areas in your ICPAM system.

- To open the dialog for modifying an existing anti-passback area, select the area (by clicking on its name in the first column of the table) and click on the **Edit...** button.
- To open the dialog for creating a new anti-passback area, select the area (by clicking on its name in the first column of the table) and click on the **Add...** button.
- To delete an anti-passback area, select the area (by clicking on its name in the first column of the table) and click on the **Delete** button.

**Step 2** Click on the appropriate button in the toolbar. For this example, click on the **Add...** button.



- Step 3** In the resulting **Add - Anti-Passback Area** dialog (shown in [Figure 11-5](#)), define the properties of the new anti-passback area:

*Figure 11-5 Add Anti-Passback Area dialog*

- a. In the **Name** field, type a unique descriptive name for this anti-passback area.
- The **Anti-passback area number** is a sequential ID number assigned by the system.
- b. (Optional) In the **Comments** field, type a brief description of this anti-passback area.
  - c. If the hierarchical location map has been defined for your ICPAM system, then you can select this anti-passback area's location from the **Location** drop-down list.
    - To view the available locations as the hierarchical location map (instead of a flat drop-down list), click the **Choose...** button.
    - To clear the current value displayed in the **Location** drop-down list, click the **Clear** button.

For more information about locations, see [Viewing Doors and Devices by Location, page 5-7](#) and [Creating the Location Map, page 5-8](#).
  - d. From the **Anti-passback mode** drop-down list, select one of the available operational modes. (Of course, a badge which is not authorized to enter a particular door is always denied access there.)
    - **Hard (Deny same area)**: When a passback situation is detected, deny access to an authorized badge, report the passback violation to the ICPAM Server, and display a Denied Access event in the **Events and Alarms** module.
    - **Soft (Grant Access)**: Grant access to an authorized badge even when a passback situation is detected, but report the passback violation to the ICPAM Server. The **Anti-Passback Monitoring** window's content also refreshes to display the new Swipe-in Time for this badge.
    - **Timed (Deny same area)**: When a passback situation is detected, always report the passback violation to the ICPAM Server. The time specified in the **Anti-passback delay** field determines when access is granted:
      - If the same badge is used twice in a row **within** the specified time, then access is denied (and a passback violation is reported).
      - If the same badge is used twice in a row **after** the specified time, then access is granted and no passback violation is reported.

- **Soft Timed (Grant Access):** Available only for EM-100 controllers, this mode will always grant access to an authorized badge even when it is used twice in a row at this area's access point. The time specified in the **Anti-passback delay** field determines when a passback violation is reported:
    - If the same badge is used twice in a row **within** the specified time, then access is granted but a passback violation is reported.
    - If the same badge is used twice in a row **after** the specified time, then access is granted and no passback violation is reported.
  - e. If you selected the **Anti-passback mode** of either **Timed (Deny same area)** or **Soft Timed (Grant Access)**, then in the **Anti-passback delay** field, type the time interval (in seconds) during which a passback violation will cause:
    - access to be denied for the **Timed (Deny same area)** mode
    - the passback violation to be reported for the **Soft Timed (Grant Access)** mode
  - f. Click the **Save and Close** button to save the settings and close this dialog.
- Step 4** Back in the **Anti-Passback Areas** window (shown in [Figure 11-4](#)), assign an entry door and an exit door to the new anti-passback area:
- a. If necessary, expand the tree in the left pane.
  - b. Click on the **Anti-Passback Area (Entry)** column in the right pane's table, click on the desired entry door in the left pane's tree, and then click on the right arrow button located between the panes.
  - c. Click on the **Anti-Passback Area (Exit)** column in the right pane's table, click on the desired exit door in the left pane's tree, and then click on the right arrow button located between the panes.
- 

## Using Local (Controller) Credentials if Network Communication is Lost

If network communication is lost between the access control controllers and the ICPAM appliance, the entry and exit doors will fail to grant access to users since the user credentials cannot be verified. To prevent this scenario, you can configure the doors to authenticate user credentials locally (using credential data stored on the door's controller).

### Usage Notes

- Allowing local controller authentication as described in this section means that the badge can be used multiple times (potentially by different users) at the entry controller. Use the local authentication option only if necessary. APB areas are only fully effective when stable network communication exists between the controllers and the ICPAM appliance.
- We recommend using the *Soft (grant access)* anti-passback mode when local controller credentials are used. See the [“Configuring Anti-Passback Areas”](#) section on page 11-22.
- A *Gateway authenticated APB Grant Access* event is generated when an APB controller authenticates a badge locally.
  - After network communication is reestablished between the controller and the ICPAM appliance, any controller authenticated APB grant access events are synchronized with the appliance.

- The appliance uses the events to determine the APB status of badges. For example, if a controller used local credentials to grant access to a badge at the entry door while the network was down, the badge will be added to the APB area by the ICPAM appliance when the network communication is reestablished. When the user swipes their badge at the exit door, the ICPAM appliance evicts the badge from the APB area.
- If the entry and exit doors are configured to use two different controllers, it is possible that a user can become trapped in an APB area. This can occur under if the user is granted access to the APB area using local credentials stored on the entry controller, and network communication is restored between ICPAM and the (second) exit door controller while the user is still in the APB area (before they access the exit door controller). This occurs because there is no record on the ICPAM appliance that the user entered the APB area (the record only exists on the entry controller). To prevent this scenario, we recommend the following:
  - Configure all APB area doors on a single controller. To support more than two doors on a single controller, a Reader module is required.
  - Install working phones that can reach the ICPAM administrator within the APB area. A badge can be modified to allow one free APB pass for the trapped user.

### Procedure

To configure local authentication of user credentials (using data stored on the local controller and not the ICPAM appliance), do the following:

- 
- Step 1** Use either the **Hardware - Tree** or **Locations & Door** module to edit the door or door template configuration.
- For example, choose **Hardware - Tree** from the Doors menu, expand the hardware tree, right-click on the door name, and select **Edit**. You can also double-click the device name to open the edit window.
  - To change the settings for a single door, see the “[Modifying Door Configurations](#)” section on [page 7-11](#).
  - To change the settings for a door template, see the “[Configuring Door Templates](#)” section on [page 8-2](#) and the “[Door Configuration Properties](#)” section on [page 8-28](#).
- Step 2** Select the **Properties** tab ([Figure 11-6](#)).

Figure 11-6 Authenticating Credentials Locally (at the Controller)

The screenshot shows the 'Edit - Door' configuration window with the 'Properties' tab selected. The 'If server unreachable (APB)' dropdown menu is highlighted in green and set to 'Deny'. Other settings include: Relock time interval (5), Door held open time (10), Door lock on close (Yes), Deadbolt engage delay (empty), Scheduled door mode (Close), Door enable schedule (TRAINING LUNCH DOOR SCHEDULE), First unlock (No), Default mode (Lock), If badge not in gateway (Use Server), Access decision on timeout (Deny), If server unreachable (Deny), Server access timeout (15), ADA time interval multiplier (2), Door swing activation delay (empty), Door swing usage (empty), Generic reader (empty), Multifactor authentication timer (10), and Toggle door mode (No).

**Step 3** Uncheck the box for **If server unreachable (APB)**. This allows you to edit the setting.

**Step 4** Choose **Authenticate locally** from the drop-down list.

**Step 5** Click **Save and Close**.

**Step 6** Download the configuration change.

See the “[Applying Configuration Changes](#)” section on page 7-14.

## Evicting a Badge from APB if the User Does Not Enter the APB Area



### Note

This topic applies only to Cisco Gateway controllers. For information about the similar functionality available for Identiv EM-100 controllers, see [Resetting the Status of All Card Holders \(at Online EM-100 Controllers\)](#), page 11-29.

If a user presents their badge and is granted access to an APB area, but decides not to enter the door, then a *Door Not Used* event is generated by the door’s controller. To prevent the badge from being added to the anti-passback monitoring list, enable the system configuration setting for **Evict most recent badge from APB area when door not used**.

**Usage Notes:**

- This setting is only effective when the user presents their badge and then walks away without physically opening the door. If the user physically opens the door but then walks away without actually entering the APB area, the *Door Not Used* event is NOT generated and the badge is added to the APB area for monitoring. If this occurs, you must manually evict the badge from the APB area using the **Anti-Passback Monitoring** module.
- If a user presents their badge at the exit door of an APB area, the badge is evicted from the APB area. However, if the user does not open the door, and a *Door Not Used* event occurs, the badge is re-added to the APB monitoring area. In this scenario, the exit door name will be used as the new entry door (as opposed to the original entry door name).
- If a badge is evicted from the APB area after a *Door Not Used* event, as described above, and then later added back to the APB area when the user accesses the door again, then the entry door is not displayed in the **Anti-Passback Monitoring** module. The exit door is displayed instead.
- We recommend using the *Soft (grant access)* anti-passback mode when local controller credentials are used. See the [“Configuring Anti-Passback Areas” section on page 11-22](#).

**Procedure**

To evict badges from an APB area when a *Door Not Used* event is generated by the door’s controller, do the following:

- 
- Step 1** Select **System Configuration** from the Admin menu.
  - Step 2** Click the **Advanced Settings** tab ([Figure 11-7](#)).
  - Step 3** Select the check box for **Evict most recent badge from APB area when door not used**.

Figure 11-7 Advanced Settings

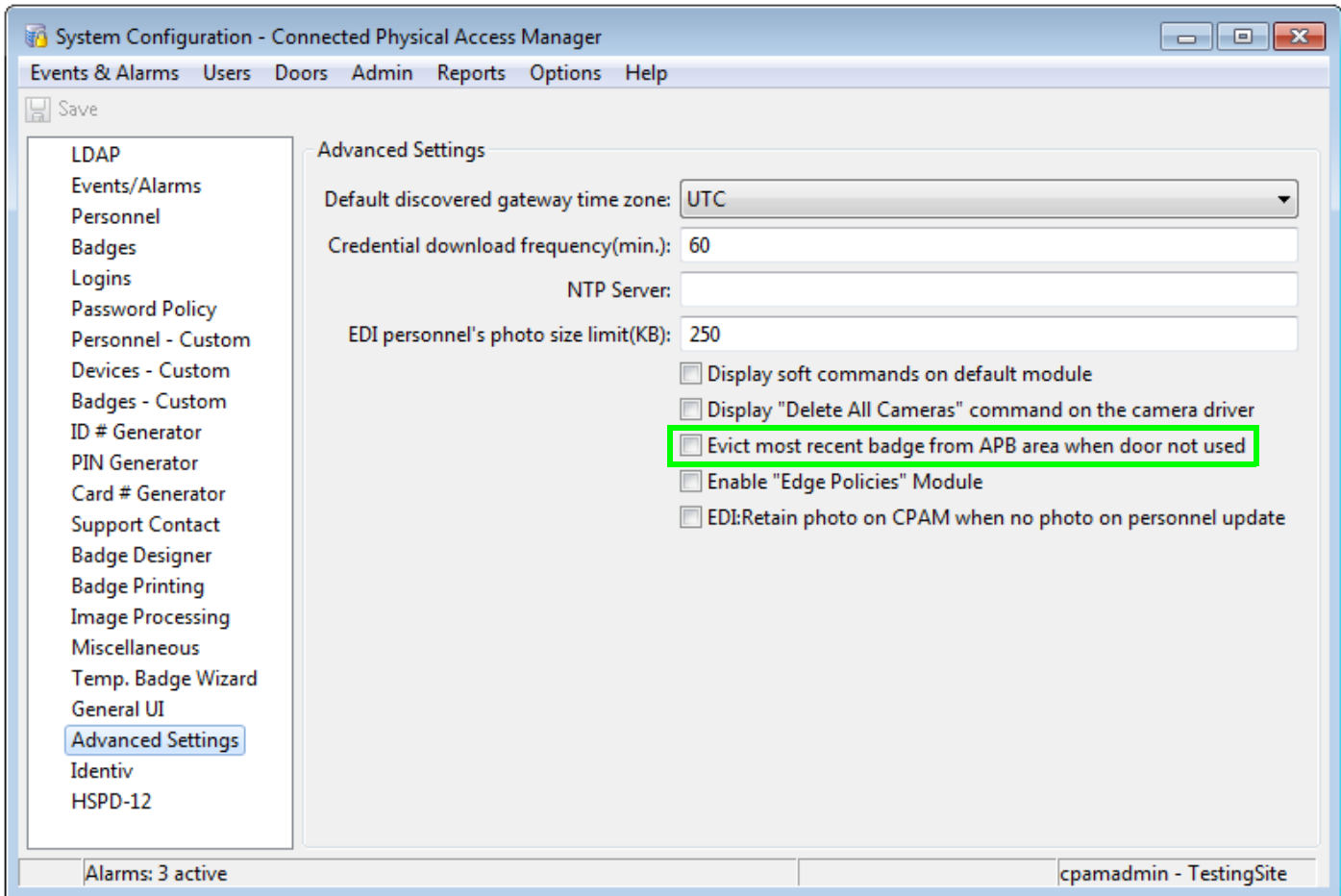

- Step 4** Restart the ICPAM appliance to activate the change. See the [Using the Web Admin Menus, Commands, and Options, page 2-19](#) for more information, or ask your system administrator for assistance.

## Resetting the Status of All Card Holders (at Online EM-100 Controllers)

If you are using anti-passback areas, there will be some situations (such as after an emergency evacuation of an area) where you must manually reset the status of some card holders or some anti-passback areas. This can be done using the **Reset Badges** button or the **Reset Area** button on the **Anti-Passback Monitoring** window's toolbar.

To quickly reset the status of all card holders at online EM-100 controllers, perform the following steps.

- Step 1** Open the Hardware Tree module by selecting **Doors > Hardware - Tree**, and if necessary select **View > Device**.
- Step 2** Expand the tree under the **Driver Manager > Identiv EM-100 Driver** so the EM-100 controllers are visible, and then either:
  - To reset the status at a specific EM-100 controller which is currently online, right-click on that controller and choose the **Reset All Card Holder Status** command.
  - To reset the status at all EM-100 controllers which are currently online, right-click on the **Identiv EM-100 Driver** item and choose the **Reset All Card Holder Status** command. For example:

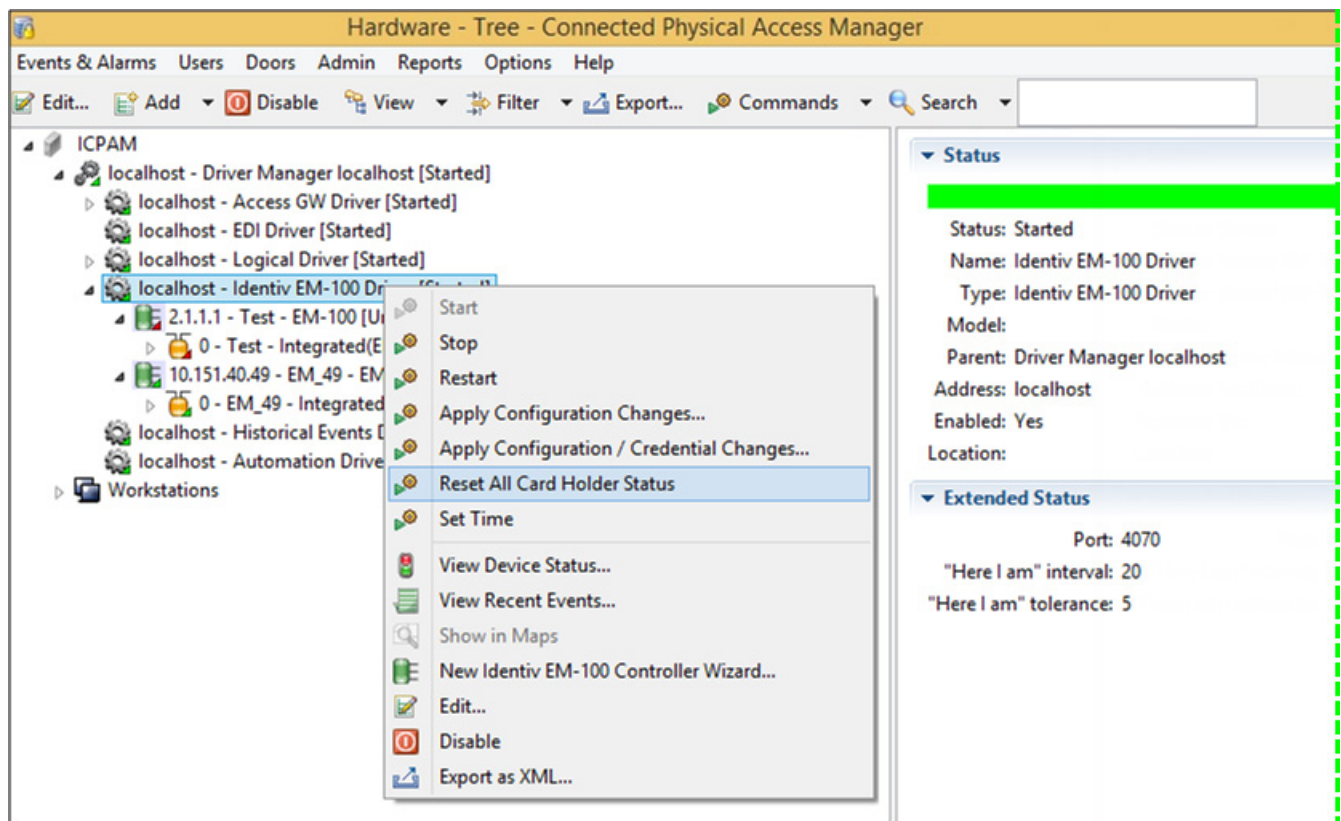

## Monitoring Anti-Passback Events

Use **Anti-Passback Monitoring** to view the badges that are in an anti-passback area. For example, if a user enters an anti-passback area using their badge, an entry is added to the Anti-Passback Monitoring window as shown in [Figure 11-8](#). This entry remains in the list until the user exits the anti-passback area.

- To view the badges currently in any anti-passback area, select the **Anti-Passback Monitoring** module from the Doors menu, under the Access Policies submenu. [Figure 11-8](#) shows the main window.
- To reset the state of a badge, select an entry and click the **Reset** button.

*Figure 11-8 Anti-Passback Monitoring window*

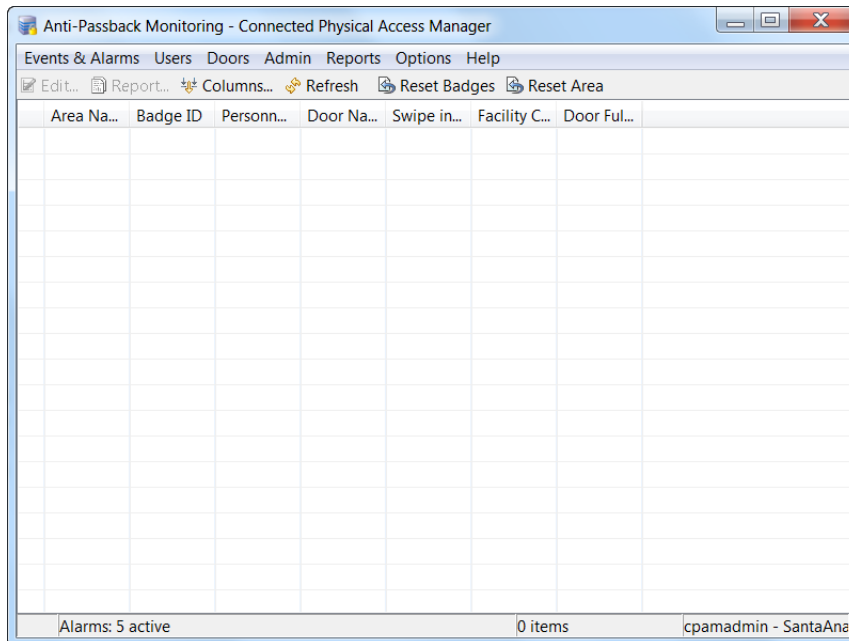

*Table 11-2 Table Columns on the Anti-Passback Monitoring window*

Column	Description
<b>Area Name</b>	The anti-passback area accessed by the badge. See <a href="#">Creating and Managing Anti-Passback Areas, page 11-19</a> for more information.
<b>Badge ID</b>	The ID number of the badge.
<b>Door Name</b>	The name of the door accessed.
<b>Policy Name</b>	The name of the Anti-Passback area. See <a href="#">Creating and Managing Anti-Passback Areas, page 11-19</a> for more information.
<b>Swipe In Time</b>	The day and time when the entry door was accessed.
<b>Facility Code</b>	The facility code.



## Anti-Passback Events Displayed in the Events Module

An event is also generated whenever a badge holder swipes a badge in an anti-passback area. These events are displayed in the Events module, as described in [Viewing Events, page 12-3](#).

For example, if a badge is swiped at a door configured with the anti-passback mode *Hard (deny access)*, an event is generated such as “Badge is not Authorized due to Hard Anti-Passback policy”. A badge swiped at a door with the mode *Soft (grant access)* generates an event “Badge is Authorized”.

## Two-Door Policies

A two-door policy requires that when a user accesses a door, they must also access a second door in a set number of seconds.

### Two-Door Policies in ICPAM 2.1

If the profile enhancement feature is set in the system configuration settings (see [Logins page of the System Configuration window, page 17-11](#)), the following changes are impacted in this module:

- The Two-Door Policy displays doors in the user’s assigned location only. The user can view and edit doors accordingly.
- The **Hierarchical location** field is auto-populated for a profile when a new policy is created.
- When a location-restricted user selects the doors for the Two-Door policy, only doors within the user’s location are listed for selection.
- The cpamadmin should assign appropriate locations for the Two-Door Policy and its corresponding doors with that of the logged in user for the existing Two-Door policy to avoid any behavior discrepancy.
- The Two-Door policy monitoring page displays all badges but the location-restricted user can reset badges which are only related to the location-restricted user’s location.



Note

These points are applicable only when the profile enhancement feature is set on the **Logins** page of the **System Configuration** window (starting with the ICPAM 2.1 release); otherwise, the ICPAM appliance retains its behavior as in the previous version (CPAM 1.5.1).

## Configuring Two-Door Policies

To configure two-door policies, do the following:

- 
- Step 1** Select **Two-Door Policy** from the Doors menu, under the Access Policies submenu.
- Step 2** In the resulting **Two-Door Policy** main window (shown in [Figure 11-9](#)), click a toolbar button.
- To modify an existing policy, select the entry and choose **Edit...** to open the detail window. You can also double-click the entry.
  - To add a new policy, click **Add...** to open the detail window.
  - To remove an policy, highlight the entry and click **Delete**.

Figure 11-9 Two-Door Policy main window

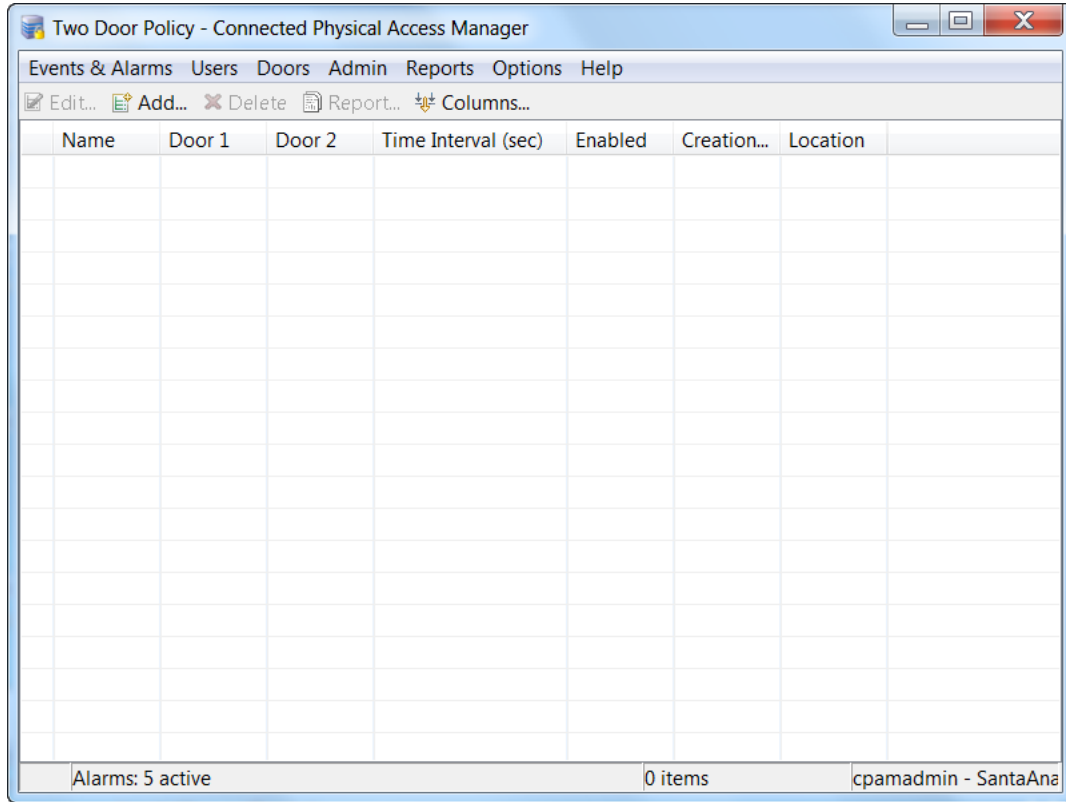

**Step 3** Complete the fields in the detail window, as shown in [Figure 11-10](#):

Figure 11-10 Add Two-Door Policy detail window

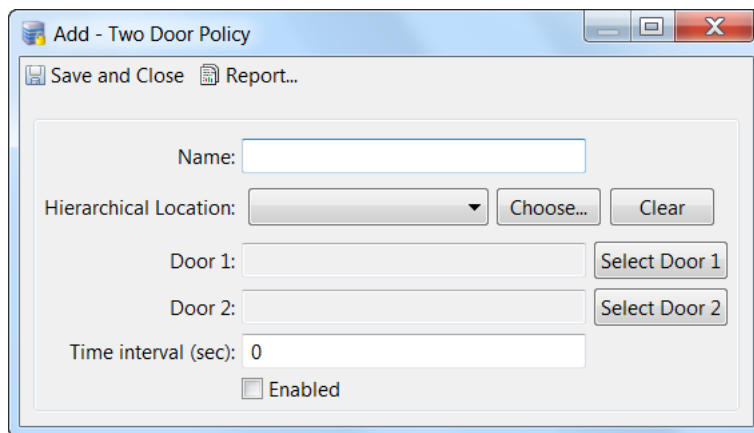

- **Name:** Enter a short description of the policy. For example: *Building 1 lab doors*.
- **Door 1:** Click **Select Door 1** to open the pop-up window ([Figure 11-11](#)). Select a door from the list and click **OK**. The door should include an exit reader in addition to an entry reader. Use the search field at the top of the window to narrow the list of doors, if necessary.

- **Door 2:** Click **Select Door 2** to open the pop-up window. Select a door from the list and click **OK**. Use the search field at the top of the window to narrow the list of doors, if necessary. Door 2 does not require an exit reader.
- **Time Interval (sec):** Enter the maximum time, in seconds, that a user is allowed between accessing the first door and the accessing the second door.
- **Enabled:** Check the enabled box to enable the policy.

**Note**

The doors are filtered and displayed based on the user's assigned location.

*Figure 11-11 Select Door 1 window*

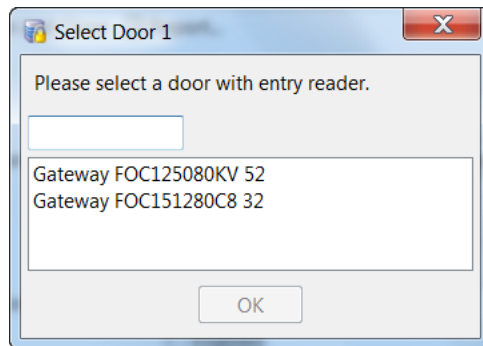

**Step 4** Click **Save and Close** to save the changes and close the detail window.

**Tip**

While configuring a two-door policy, it is required to have all the entities that is the policy location and the door in the policy in the location of the logged in user.

# Two-Door State Monitoring

Use the Two-Door State Monitoring module to display events for doors configured with the Two-Door Policy module.

- Step 1** Select **Two-Door State Monitoring** from the Doors menu, under the **Access Policies** submenu.
- Step 2** In the resulting main window (shown in [Figure 11-12](#)), click on an event and click **Edit...** to display details about that event.

*Figure 11-12 Two-Door State Monitoring main window*

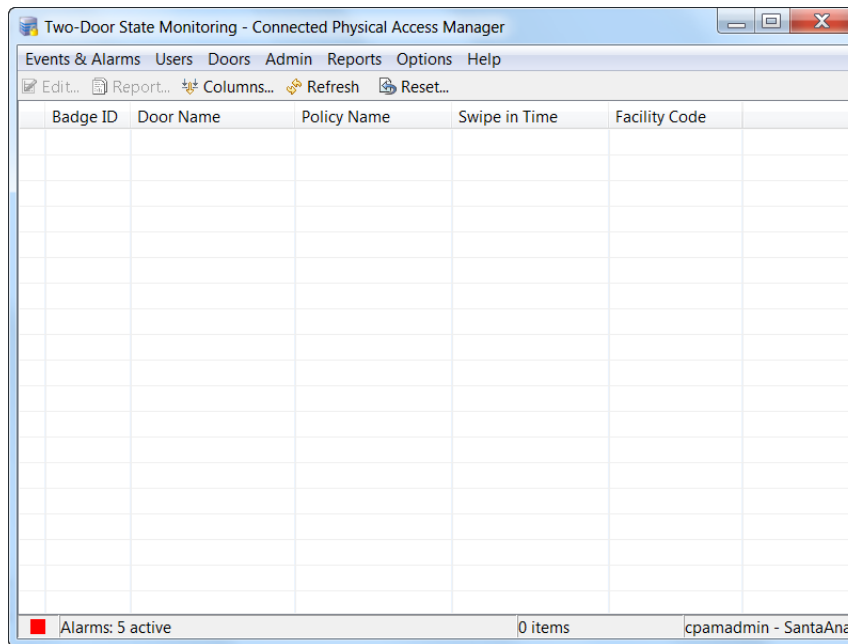

A two-door state event has the properties described below, available in the table view or detail window:

*Table 11-3 Table Columns on the Two-Door State Monitoring main window*

Field	Description
<b>Badge ID</b>	The ID number of the badge.
<b>Door Name</b>	The name of the door accessed.
<b>Policy Name</b>	The name of the two-door policy. See <a href="#">Two-Door Policies, page 11-31</a> for more information.
<b>Swipe In Time</b>	The day and time when the entry door was accessed.
<b>Facility Code</b>	The facility code.

- Step 3** Click **Close** to close the detail window.

## Events & Alarms

---

This chapter describes how to view events and alarms in ICPAM. It also includes instructions to configure the event policies that define how events are captured and managed.

Events can be viewed in the following ways:

- As a list using the Events or Alarms modules.
- Using an audit trail of events initiated by a user.
- By personnel photos.
- Using graphic maps to display where events occur on a floor or building. You can also use the map to trigger actions for a device or door.

**Tip**

---

To create actions that are triggered by an event, see [Chapter 13, “Configuring Automated Tasks”](#). To view live and recorded video for events and alarms, see [Chapter 15, “Video Monitoring”](#).

---

**Contents**

- [Viewing Events, Alarms, and Audit Trail Records, page 12-2](#)
  - [Events and Alarms in ICPAM 2.1, page 12-3](#)
  - [Viewing Events, page 12-3](#)
  - [Viewing Alarms, page 12-8](#)
  - [Viewing Audit Trail Records, page 12-20](#)
  - [Viewing Recent Events for a Device, Driver, or Location, page 12-23](#)
- [Viewing Events Using Personnel Photos, page 12-24](#)
  - [Viewing Event Photos, page 12-24](#)
  - [Adding a Color Border to Event Photos \(Credential Watch\), page 12-25](#)
  - [Using Filters to Limit the Photos and Doors Events Displayed by Event Photos, page 12-29](#)
- [Recording External Events, page 12-33](#)
- [Viewing Workstation Activity, page 12-36](#)
- [Configuring Events and Alarms, page 12-37](#)
  - [Modifying Default Event Policies, page 12-37](#)
  - [Event Policy Manager in ICPAM 2.1, page 12-38](#)
  - [Automatically Open the Alarms Window, page 12-42](#)

- [Configuring Time Schedules, page 12-43](#)
- [Configuring Alert Sounds, page 12-46](#)
- [Setting Event and Alarm Priorities, page 12-47](#)
- [Defining User Privileges for Editing Events, page 12-48](#)
- [Using Graphic Maps, page 12-49](#)
  - [Graphic Maps in ICPAM 2.1, page 12-49](#)
  - [Maps Viewer, page 12-50](#)
  - [Map Editor, page 12-55](#)
- [Backing Up and Archiving Events, page 12-63](#)
  - [Including Events In System Backups, page 12-63](#)
  - [Pruning and Archiving Old Events, page 12-63](#)
  - [Creating Reports from Pruned Events, page 12-64](#)

## Viewing Events, Alarms, and Audit Trail Records

Events and alarms are captured in real time, and are accessed in the **Events & Alarms** menu, under the **Monitoring** submenu. Alarms are critical or important events. Audit trails are events initiated by users.

This section includes the following:

- [Understanding Live and Archived Events, page 12-3](#)
- [Understanding Event Timestamps, page 12-3](#)
- [Viewing Events, page 12-3](#)
- [Viewing Alarms, page 12-8](#)
  - [Alarm States, page 12-9](#)
  - [Alarm Detail Window, page 12-10](#)
- [Viewing Audit Trail Records, page 12-20](#)



**Tip**

---

See [Configuring Events and Alarms, page 12-37](#) to define or modify event types. To copy or move events to a historical events archive, see [Backing Up and Archiving Events, page 12-63](#).

---

## Events and Alarms in ICPAM 2.1

If the profile enhancement feature is set in the system configuration settings ([Logins page of the System Configuration window, page 17-11](#)), the following changes are impacted in this module:

- The events and alarms are displayed to users based on hierarchical location assigned to their user profiles. For example: if a location-restricted user “campusadmin” is assigned to a location “San Jose Campus”, the user can view events and alarms related to this location and its sub locations only.
- The location-restricted user cannot view events of the following drivers and modules:
  - Driver level commands
  - Cleared Alarms event
  - Device commands
  - Workstation
  - Audit Trail



Note

---

These points are applicable only when the profile enhancement feature is set on the **Logins** page of the **System Configuration** window (starting with the ICPAM 2.1 release); otherwise, the ICPAM appliance retains its behavior as in the previous version (CPAM 1.5.1).

---

## Understanding Live and Archived Events

- You can include or exclude events from system backups. Excluding events reduces the size of the backup file.
- The Event Monitoring window includes all live events in the system. Live events can be pruned to remove them from the main database to improve system performance. Pruned events are not displayed in the Event Monitoring window. Old events can also be archived and backed up to a remote server.

See the [“Backing Up and Archiving Events” section on page 12-63](#) for more information.

## Understanding Event Timestamps

Beginning with CPAM Release 1.3.0, events display the timestamp of the ICPAM PC workstation used to view the events. In previous releases, events displayed the ICPAM appliance timestamp.

## Viewing Events

You can view events in a list, or double-click an event to view detailed information. You can also right-click an event to select commands, change the event properties, or view associated video.

---

**Step 1** Select **Events** from the **Events & Alarms** menu, under the **Monitoring** submenu.

The Events window ([Figure 12-1](#)) shows the most recent events in the access-control system.

Figure 12-1 Events Module main window

Time	Description	Device	Personnel Record	Credential	Data
8/24/2015 15:54:57	Workstation: Logged In	MaryJo-Opti9020			
8/24/2015 15:54:57	Operator logged in	MaryJo-Opti9020		cpamadmin	
8/24/2015 15:50:04	Operator logged out	MaryJo-Opti9020		cpamadmin	
8/24/2015 15:40:51	Credential records group-...				Total: 3; Processed:...
8/24/2015 14:21:55	Gateway Driver command:...	MaryJo-Opti9020		cpamadmin	
8/24/2015 14:21:42	Gateway Driver command:...	MaryJo-Opti9020		cpamadmin	
8/24/2015 13:28:38	Workstation: Logged In	CPAM-PC			
8/24/2015 13:28:38	Operator logged in	CPAM-PC		cpamadmin	
8/24/2015 13:06:40	Gateway Controller comm...	MaryJo-Opti9020		cpamadmin	
8/24/2015 10:26:42	Operator logged out	CPAM-PC		cpamadmin	
8/24/2015 10:26:42	Workstation: Logged Out	CPAM-PC			
8/21/2015 13:31:50	HID Controller command: ...	MaryJo-Opti9020		cpamadmin	
8/21/2015 13:30:11	HID Driver: Started	HID Driver			
8/21/2015 13:30:11	HID Controller: Offline	EVO 1 - Edge			
8/21/2015 13:30:09	HID Driver: Starting	HID Driver			
8/21/2015 13:30:09	Driver command: Start	MaryJo-Opti9020		cpamadmin	
8/21/2015 13:30:06	HID Driver: Stopped	HID Driver			
8/21/2015 13:30:06	HID Driver: Stopping	HID Driver			
8/21/2015 13:30:06	Driver command: Stop	MaryJo-Opti9020		cpamadmin	
8/21/2015 13:29:13	HID Driver: Started	HID Driver			
8/21/2015 13:29:13	HID Controller: Offline	EVO 1 - Edge			
8/21/2015 13:29:12	HID Driver: Starting	HID Driver			
8/21/2015 13:29:12	HID Driver: Stopped	HID Driver			
8/21/2015 13:29:12	HID Driver: Stopping	HID Driver			
8/21/2015 13:29:12	Driver command: Restart	MaryJo-Opti9020		cpamadmin	

Alarms: 5 active | 100+ items | cpamadmin - SantaAnaCR

**Note** Beginning with CPAM Release 1.3.0, events display the timestamp of the ICPAM PC workstation used to view the events. (In previous releases, events displayed the ICPAM appliance timestamp.)

**Step 2** Modify the list of records using the following toolbar controls:

- **Scroll Lock:** Disables or enables automatic scrolling of the list as new events are inserted.
- **Clear List:** Clears all events from the table. Only new events are displayed.
- **View...:** Select an event and click View to display the detail window (Figure 12-2). You can also double-click an event to view its details.
- **Report...:** View the selected events in a separate window, or save the information in a file. See [Creating Reports, page 3-10](#).
- **Columns...:** Define the columns displayed and their order. See [Revising the Column Display, page 3-14](#).
- **Filter:** Filter the events to display a subset of records. To change the number of viewable events, select **Max rows**. See [Using Filters, page 3-12](#).
- **Search:** Search the set of records. See [Search, page 3-15](#).

**Step 3** For example, select a record and click **View...** to open the detail window (shown in Figure 12-2).



Figure 12-2 Events Module detail window

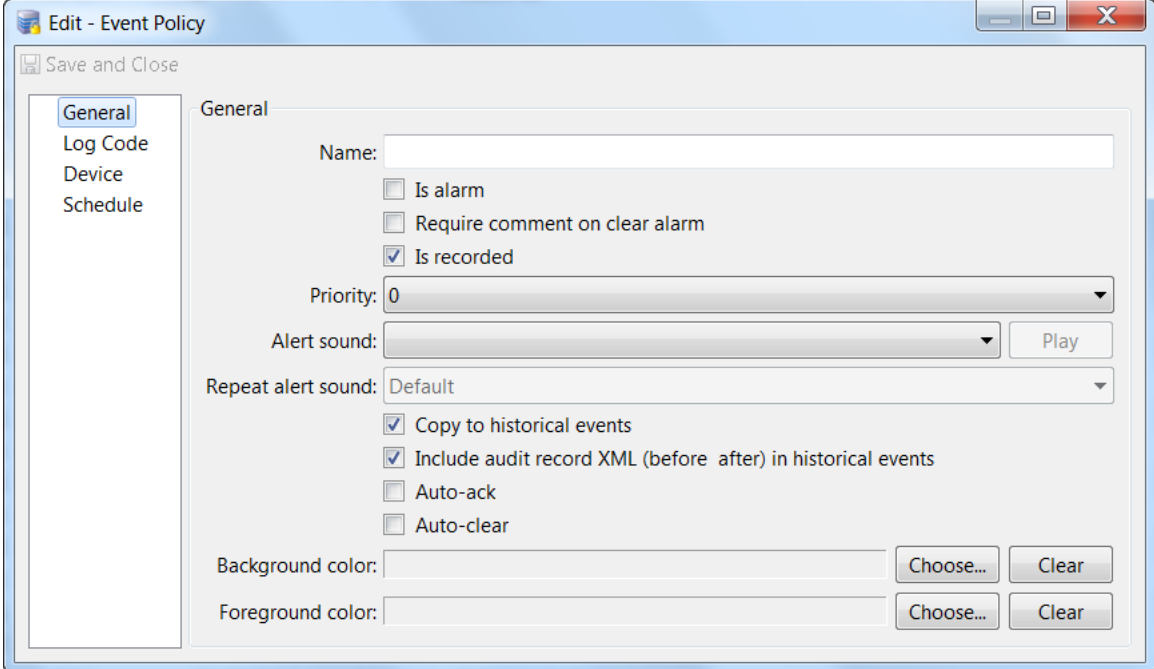

**Step 4** Review the properties and actions for the record. See [Table 12-1](#) for field descriptions.



**Note** The fields which are available vary depending on the type of event. The following example is for a door event.

Table 12-1 Event Properties

Field	Description
<b>Time</b>	The time and date when the event occurred.  <b>Note</b> Beginning with CPAM Release 1.3.0, events display the timestamp of the ICPAM PC workstation used to view the events. In previous releases, events displayed the ICPAM appliance timestamp.
<b>Time received</b>	The time the event was received and stored in the database. If the event was processed by an external device such as a controller, this may differ from the time, depending on delays or interruptions in communications between the host and the device.
<b>Type</b>	The type of event. The types of events are: <ul style="list-style-type: none"> <li>• <b>Event:</b> A general occurrence within the system, often from external hardware such as a controller.</li> <li>• <b>Alarm:</b> An event configured to be an alarm.</li> <li>• <b>Alarm Annotation:</b> An event caused by commenting, clearing, or acknowledging alarms.</li> <li>• <b>Audit Record:</b> An event caused by an operator modifying a record, such as a badge or personnel record.</li> <li>• <b>Device Command:</b> An event caused by an operator executing a device command.</li> <li>• <b>Device Command Result:</b> Notification of a completed device command.</li> </ul>
<b>Log Code</b>	The internal code to identify the event. Log codes can be viewed in the <b>Event Policy Manager</b> and defined as alarms. See <a href="#">Modifying Default Event Policies, page 12-37</a> .
<b>Priority</b>	The importance level assigned to the event. Priorities range from a low of -10 to a high of 10. To configure these priorities, see <a href="#">Setting Event and Alarm Priorities, page 12-47</a> .
<b>Description</b>	A description of the event.
<b>Device</b>	The device associated with the event, such as a workstation or hardware module. <ul style="list-style-type: none"> <li>• <b>Edit...:</b> Displays information about the device including type, name, and address. Some fields are editable, depending on the type of device.</li> <li>• <b>View Status...:</b> Displays the status of the associated device. For example, if the workstation is logged in to the system or if the hardware module is enabled.</li> <li>• <b>Commands:</b> lists any available commands for the device. For example, apply a controller configuration, or send a message to a workstation.</li> <li>• <b>Show in Graphics Map:</b> see <a href="#">Maps Viewer, page 12-50</a>.</li> </ul>
<b>Credential</b>	If the event has an associated credential (such as a badge or login), the identifying information of the credential (such as a card or username) is displayed in this field. <ul style="list-style-type: none"> <li>• <b>Edit...:</b> Revise the credential (badge, login, etc.) record associated with the event.</li> </ul>

Table 12-1 Event Properties (continued)

Field	Description
<b>Personnel Record</b>	<p>If a personnel record is associated with the event, this field displays the person's name.</p> <ul style="list-style-type: none"> <li>• <b>Edit...:</b> Edit the personnel record associated with the event.</li> <li>• <b>View Photo...:</b> Displays the associated personnel record photo, if any.</li> </ul>
<b>Data</b>	<p>This field displays detailed information about the event, the exact value and meaning of which depends on the type of event. This field is generally for advanced or troubleshooting use. If the event is associated with an attempt to gain access to an access point using a badge that is not in the database, then this field contains the card number.</p>
<b>camera</b>	<p>The Video event information of a camera device.</p> <ul style="list-style-type: none"> <li>• <b>Live Video:</b> opens the video player to view live video from the camera associated with the device.</li> <li>• <b>Event Video:</b> displays archived video associated with the event, if available.</li> <li>• <b>Live and Event Video:</b> opens both live and archived video windows.</li> <li>• <b>Arrangement:</b> displays all camera arrangement that includes the camera associated with the event.</li> </ul> <p>See <a href="#">Chapter 15, “Video Monitoring”</a> for more information.</p>
<b>Parent Device</b>	Parent Device name of the device on which the event is associated.
<b>Address</b>	Address of the device associated with event.
<b>Sequence Number</b>	Sequence number of credentials during controller credential related events
<b>Watch Level</b>	Displays the credential watch level for the badge associated with the event.

## Viewing Alarms

Alarms are a type of event that indicates the event is important or requires additional attention. You can acknowledge, clear, and add comments to an alarm.

- In other modules, an alarm summary is displayed in the lower left-hand corner of the window.
- For instructions to open Alarms when an alarm occurs, see [Automatically Open the Alarms Window](#), page 12-42.

This section includes the following:

- [Alarms Main Window](#), page 12-8
- [Alarm States](#), page 12-9
- [Alarm Detail Window](#), page 12-10
- [Alarm Properties](#), page 12-10

## Alarms Main Window

To view alarms, do the following

- Step 1** Select **Alarms** from the **Events & Alarms** menu, in the **Monitoring** menu.  
The main window ([Figure 12-3](#)) shows the most recent 500 uncleared alarms.

*Figure 12-3 Alarms module main window*

Alarm State	Count	Time	Description	Device	P..
Active	1	8/19/2015 09:45:55	Configuration download to gateway failed.	Access GW Driver	
Active	1	8/19/2015 09:45:49	Configuration download to gateway failed.	Access GW Driver	
Active	1	8/18/2015 15:29:43	Configuration download to gateway failed.	Access GW Driver	
Active	2	8/18/2015 15:29:43	Configuration download to gateway failed.	Access GW Driver	
Active	6	8/18/2015 15:29:43	Configuration download to gateway failed.	Access GW Driver	

- Step 2** Modify the list of records using the following toolbar controls:
- **Scroll Lock:** Disables or enables automatic scrolling of the list as new events are inserted.
  - **Report...:** View the selected alarms in a separate window, or save the information in a file. See [Creating Reports, page 3-10](#).
  - **Columns...:** Define the columns displayed and their order. See [Revising the Column Display, page 3-14](#).
  - **Filter:** Filter the alarms to display a sub-set of records. To change the number of displayed alarms, select **Max rows**. See [Using Filters, page 3-12](#).
- Step 3** Change the state of an alarm, add a comment, or acknowledge the alarm.
- Use the following toolbar buttons, or right-click on an alarm's entry and select a command from the pop-up menu.
- **Ack:** Acknowledges an alarm, placing it in an acknowledged state. This means that the operator is aware of the alarm, but it has not been resolved. A solid orange color indicates this state.
  - **Comment:** Adds a comment to an alarm. Does not change the state of the alarm. A new comment may be entered, or a previously entered comment may be selected from the drop-down list.
  - **Clear:** Places the alarm in a cleared state (resolved) and changes the icon to green.
  - **Ack All:** Acknowledges all currently unacknowledged alarms. This means that the operator is aware of the alarms, but they have not been resolved. A solid orange color indicates this state.
  - **Comment All:** Adds a comment to all currently unacknowledged alarms. Does not change the state of the alarms. A new comment may be entered, or a previously entered comment may be selected from the drop-down list.
  - **Clear All:** Places the alarms in a cleared state (resolved) and changes the icon to green. Make sure all the alarms have been acknowledged before performing this task.
- See [Alarm States](#) for more information. The alarms state options are also available in the detail window.
- Step 4** Select an alarm and click **View...** to open the detail window ([Figure 12-4 on page 12-10](#)). You can also double-click the record. See [Alarm Properties, page 12-10](#) for field descriptions.

## Alarm States

An alarm can be in one of several states, and these states have an associated solid or blinking color, as described in [Table 12-2](#).

*Table 12-2 Alarm States*

State	Color	Description
<i>Active</i>	Blinking red	The alarm is new, unacknowledged, and unresolved.
<i>Acknowledged</i>	Solid orange	An operator has acknowledged that he is aware of the alarm, although it remains unresolved.
<i>Cleared</i>	Solid green	The alarm has been acknowledged and resolved. Note that the default filter in the <b>Alarms</b> module hides cleared alarms, so these are generally not seen.

## Alarm Detail Window

The detail window (Figure 12-4) displays alarm properties and provides a number of actions:

- The **Alarm** page displays the properties of the alarm and provides a number of actions. See [Alarm Properties, page 12-10](#) for more information.
- The **Duplicates** page displays duplicate alarms. All attributes are the same except the time.
- The **Annotations** page displays any annotations made to the selected alarm. Valid alarm annotations include:
  - Acknowledge Alarm
  - Clear Alarm
  - Comment Alarm

Figure 12-4 Alarms Module Detail Window

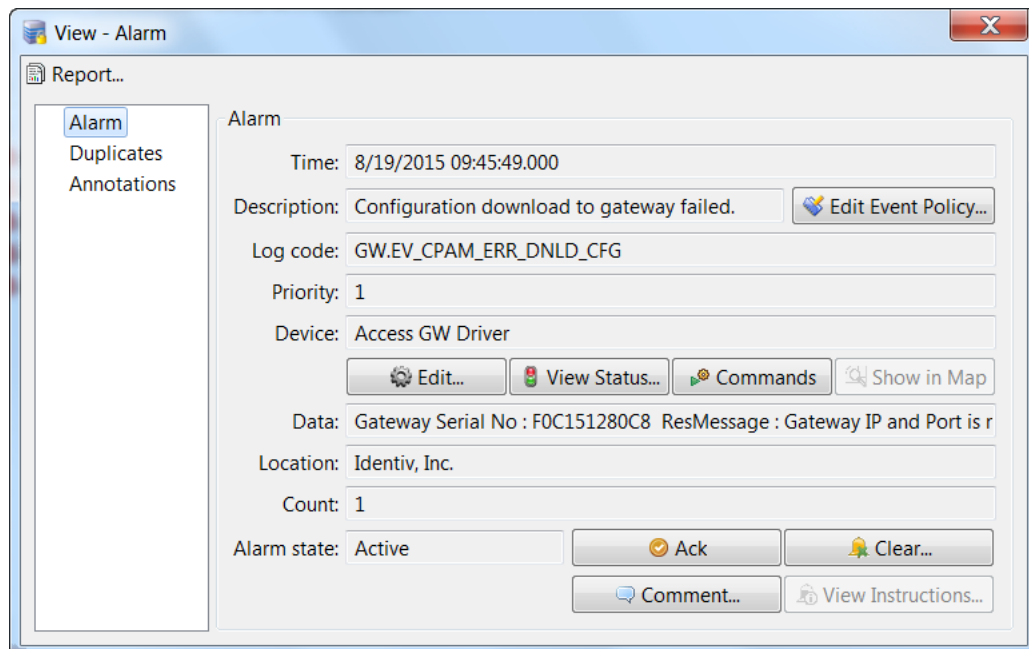

## Alarm Properties

An alarm has the following properties, available in the table view or the detail window:

Table 12-3 Alarm Properties

Field	Description
Time	The date and time when the alarm occurred.
Time Received	The time the alarm was received and stored in the database. If the event was processed by an external device such as a controller, this may differ from the time, depending on delays or interruptions in communications between the host and the device.
Site	The site where the alarm occurred.

Table 12-3 Alarm Properties (continued)

Field	Description
<b>Log Code</b>	The internal code to identify the event. Log codes can be viewed in the <b>Event Policy Manager</b> and defined as alarms. See <a href="#">Modifying Default Event Policies, page 12-37</a> .
<b>Priority</b>	The level of importance assigned to the alarm. Priorities range from a low of -10 to a high of 10. To configure these priorities, see <a href="#">Setting Event and Alarm Priorities, page 12-47</a> .
<b>Description</b>	A description of the alarm.
<b>Device</b>	The device associated with the alarm, such as a workstation or hardware module. <ul style="list-style-type: none"> <li>• <b>Edit...</b>: Displays information about the device including type, name, and address. Some fields are editable, depending on the type of device.</li> <li>• <b>View Status...</b>: Displays the status of the associated device. For example, if the workstation is logged in to the system or if the hardware module is enabled.</li> <li>• <b>Commands</b>: lists any available commands for the device. For example, apply a controller configuration, or send a message to a workstation.</li> <li>• <b>Show in Graphics</b> : see <a href="#">Maps Viewer, page 12-50</a>.</li> </ul>
<b>Credential</b>	If the alarm has an associated credential (such as a badge or login), the identifying information of the credential (such as a card or username) is displayed in this field. <ul style="list-style-type: none"> <li>• <b>Edit...</b>: Revise the credential (badge, login, etc.) record associated with the event.</li> </ul>
<b>Watch Level</b>	Displays the Credential Watch Level for the badge associated with the event. See <a href="#">Adding a Color Border to Event Photos (Credential Watch), page 12-25</a> . <ul style="list-style-type: none"> <li>• <b>Edit...</b>: Revise the credential watch level associated with the badge.</li> </ul>
<b>Address</b>	The address of the device.
<b>Personnel Record</b>	If a personnel record is associated with the alarm, this field displays the person's name. <ul style="list-style-type: none"> <li>• <b>Edit...</b>: Edit the personnel record associated with the event.</li> <li>• <b>View Photo...</b>: Displays the associated personnel record photo, if any.</li> </ul>
<b>Data</b>	This field displays detailed information about the event, the exact value and meaning of which depends on the type of event. This field is generally for advanced or troubleshooting use. If the event is associated with an attempt to gain access to an access point using a badge that is not in the database, this field contains the card number.
<b>Count</b>	The number of times this alarm has occurred, including duplicates. Duplicate alarms have all attributes the same except time).

Table 12-3 Alarm Properties (continued)

Field	Description
<b>Alarm State</b>	<p>The state of the alarm. See <a href="#">Alarm States, page 12-9</a>.</p> <ul style="list-style-type: none"> <li>• <b>Ack...</b>: Acknowledges the alarm, placing it in an acknowledged state. This means that the operator is aware of the alarm, but it has not been resolved. A solid orange color indicates this state.</li> <li>• <b>Clear...</b>: Clears the alarm, placing it in a cleared state. This means that the alarm has been resolved. A solid green color indicates this state.</li> <li>• <b>Comment...</b>: Adds a comment to an alarm. Does not change the state of the alarm. A new comment may be entered, or a previously entered comment may be selected from the drop-down list. For more on commenting, refer to <a href="#">Alarm Comments, page 12-12</a>.</li> <li>• <b>View Instructions...</b>: Opens a detail window with instructions for dealing with the type of alarm, if any. This button is only active if instructions have been previously defined for this alarm. For more on creating and viewing instructions, refer to <a href="#">Alarm Comments, page 12-12</a>.</li> </ul>
<b>Target device</b>	<p>The device associated with the event. For example, the device where a command was executed.</p> <ul style="list-style-type: none"> <li>• <b>Edit</b>: modify the device settings.</li> </ul>
<b>camera</b>	<p>The camera associated with the device.</p> <ul style="list-style-type: none"> <li>• <b>Live Video</b>: opens the video player to view live video from the camera associated with the device.</li> <li>• <b>Event Video</b>: displays archived video associated with the event, if available.</li> </ul> <p>See <a href="#">Chapter 15, “Video Monitoring”</a> for more information.</p>

## Alarm Comments

When an alarm occurs, a qualified user has the option to comment on that occurrence by doing the following:

- 
- Step 1** Right click on the alarm, and choose the **View** command from the pop-up menu.
  - Step 2** In the resulting dialog, click the **Comment** button.
  - Step 3** In the resulting comment dialog, type the comment, then click **OK**.
- 

Optionally, perform this procedure:

- 
- Step 1** In the Alarms main window, click on an alarm to select it, then click the **Comment** button in the toolbar. Alternatively, click the **Comment All** button to type a comment regarding all currently unacknowledged alarms.
  - Step 2** In the resulting comment dialog, type the comment, then click **OK**.
-



## Alarm Instructions - Creating

Instructions can be provided for any alarm or group of alarms within the system. This feature enables the qualified operator to view your instructions about how to respond to a specific alarm when that alarm occurs. Instructions can be designed to appear for the general system or be customized for specific devices, locations, time periods, or device types.

To create and customize an alarm instruction:

- Step 1** Select **Alarm Instructions** from the **Configuration** option under **Events & Alarms**.

The Alarm Instructions main window appears (Figure 12-5).

*Figure 12-5 Alarm Instructions main window*

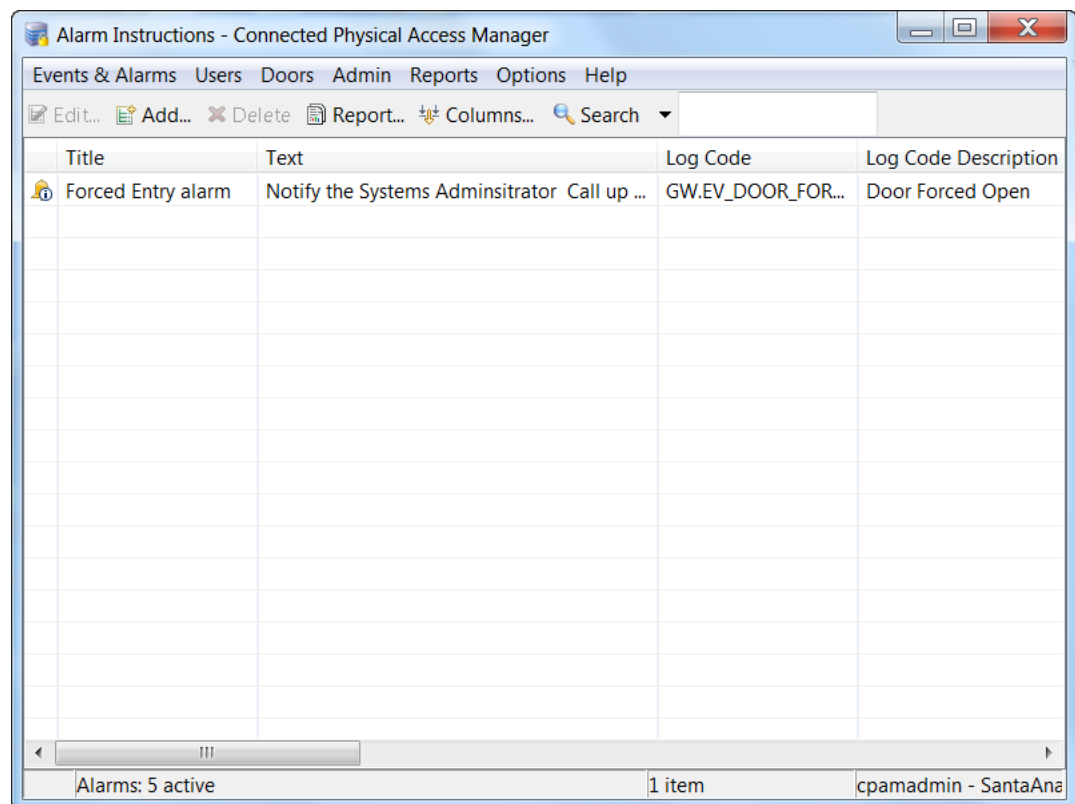

- Step 2** Click **Add...**

The Add Alarm Instructions dialog appears, as shown in Figure 12-6.

Figure 12-6 Add Alarm Instructions dialog - General page

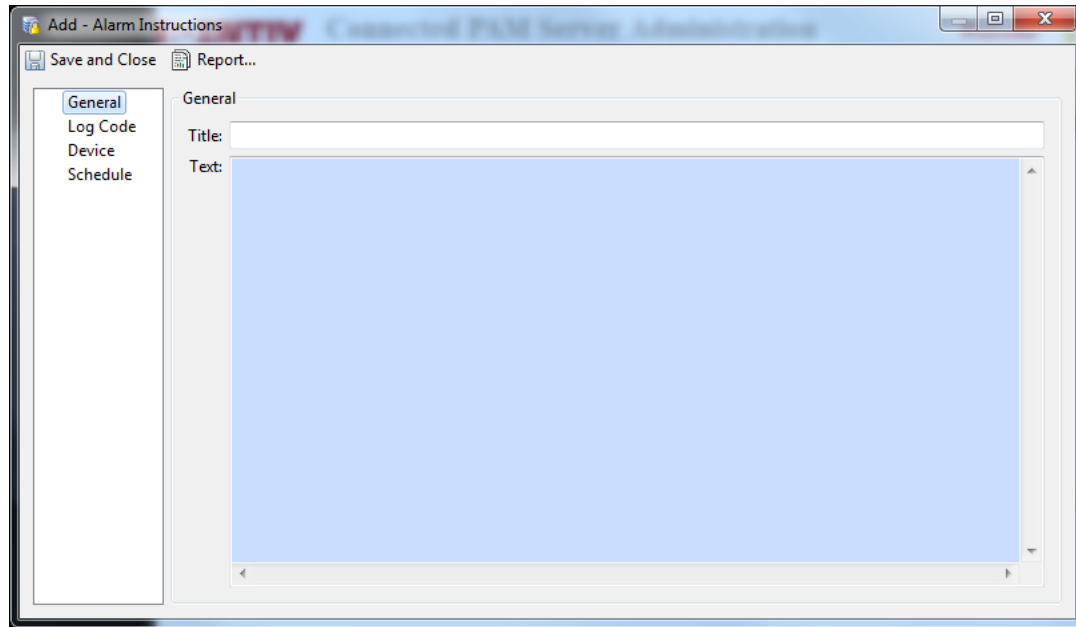

- Step 3** On the General page, type a title for this instruction, then click in the Text box and type the specific instructions that apply to this particular alarm.
- Step 4** If necessary, click the **Log Code** tab to display the Log Code page (shown in [Figure 12-7](#)).

Figure 12-7 Add Alarm Instructions dialog - Log Code page

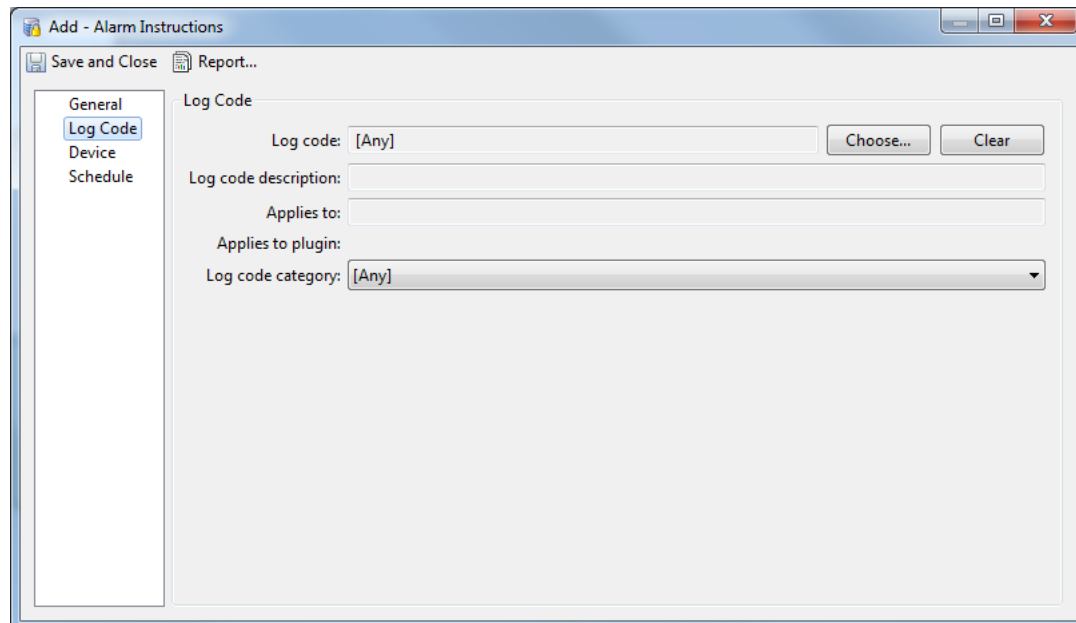

The fields available on this page include:

**Table 12-4** Fields on the Log Code page of the Add Alarm Instructions dialog

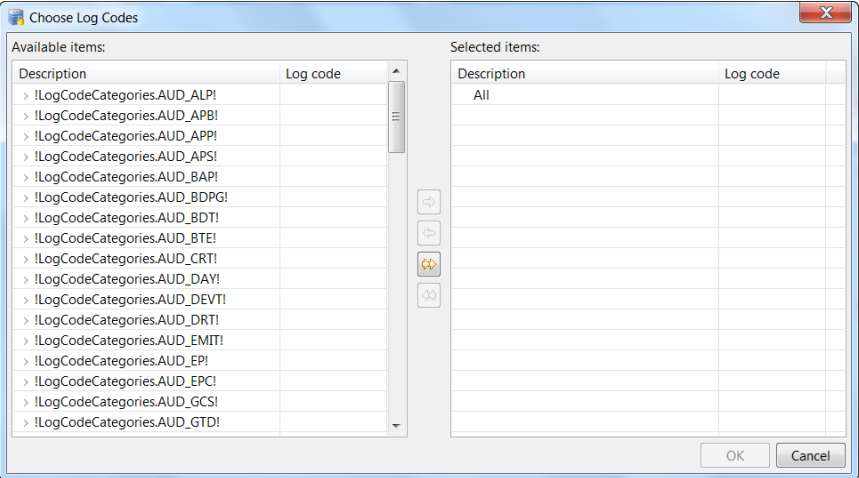
Field	Description
<b>Log code</b>	<p>The internal code to identify the event. To select a log code, click <b>Choose...</b>. The <b>Choose Log Codes</b> window appears.</p>  <p>If required, select the appropriate log code for this instruction. The default is [Any].</p> <p>Log codes can be viewed in the <b>Event Policy Manager</b> and defined as alarms. See <a href="#">Modifying Default Event Policies, page 12-37</a>.</p>
<b>Log code description</b>	Enter a description of this log code, if needed.
<b>Applies to</b>	Enter a description of the component(s) or conditions to which this log code applies.
<b>Applies to plugin</b>	If this log code applies to a plug-in component, enter a description of this.
<b>Log code category</b>	If required, click the drop-down list and select a category to which this log code set applies. The default value is [Any].

**Step 5** Click the **Device** tab to display the Device page (shown in [Figure 12-8](#)).

Figure 12-8 Add Alarm Instructions dialog - Device page

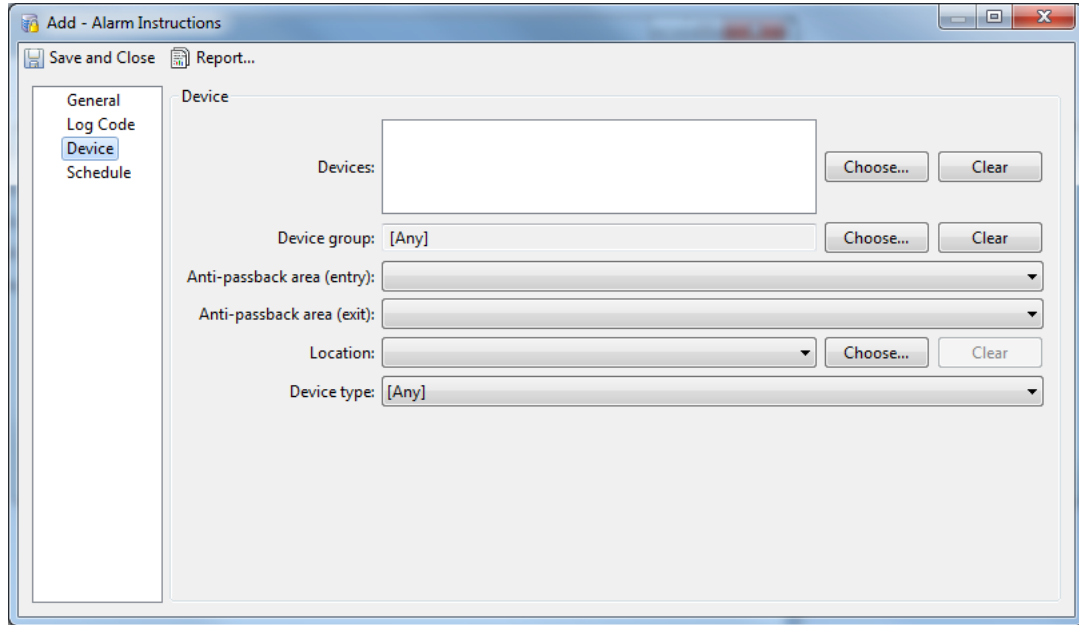

The fields available on this page include:

Table 12-5 Fields on the Device page of the Add Alarm Instructions dialog

Field	Description
Devices	<p>Enter the devices to which this instruction set applies. To include devices in this instruction set, click <b>Choose...</b> to display the Choose Devices dialog.</p>  <p>Expand the device tree as required and check the boxes of one or more devices, then click <b>OK</b>.</p>

Table 12-5 Fields on the Device page of the Add Alarm Instructions dialog (continued)

Field	Description
<b>Device group</b>	<p>Select the device group to which this instruction set applies. To select the group, click to drop down the option list.</p>  <p>Select a group then click <b>OK</b>. The default is [None].</p>
<b>Anti-passback area (entry)</b>	<p>From the drop-down list, select the entry point of the anti-passback area to which this instruction set applies.</p> <p>Only those anti-passback areas previously defined for this system appear in this list. For more on defining anti-passback areas, refer to <a href="#">Creating and Managing Anti-Passback Areas, page 11-19</a>.</p>
<b>Anti-passback area (exit)</b>	<p>From the drop-down option list, select the exit point of the anti-passback area to which this instruction set applies.</p> <p>Only those anti-passback areas previously defined for this system appear in this list. For more on defining anti-passback areas, refer to <a href="#">Creating and Managing Anti-Passback Areas, page 11-19</a>.</p>
<b>Location</b>	<p>Select one or more designated locations where this instruction set applies. Only these locations can use the instruction set.</p> <p>To specify locations, click <b>Choose...</b> to display the Location dialog.</p>  <p>Select one or more locations by checking the appropriate boxes, then click <b>OK</b>.</p>

Table 12-5 Fields on the Device page of the Add Alarm Instructions dialog (continued)

Field	Description
Device type	<p>Select the type of device to which this instruction set applies.</p> <p>To select a device type, click in this field to make a drop-down list appear.</p>  <p>Select the device type required. The default value is [Any].</p>

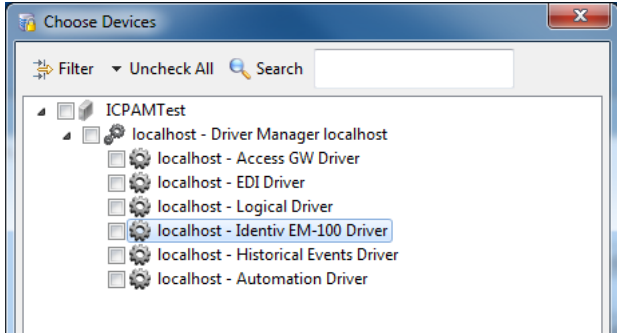
**Step 6** Click the **Schedule** tab to display the Schedule page (shown in Figure 12-9).

Figure 12-9 Add Alarm Instructions dialog - Schedule page

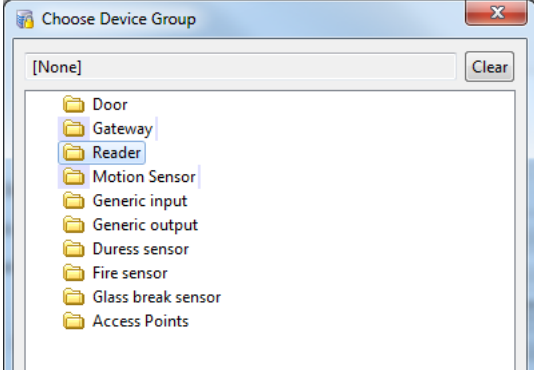
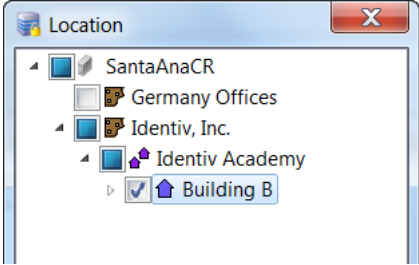
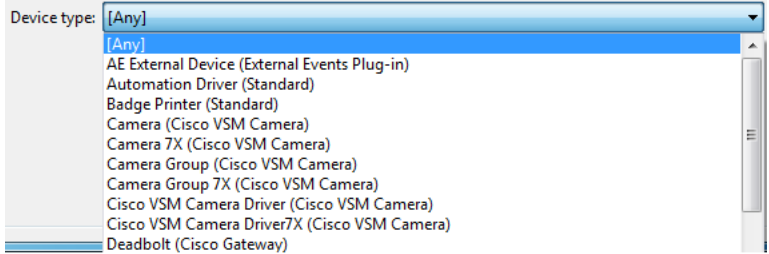
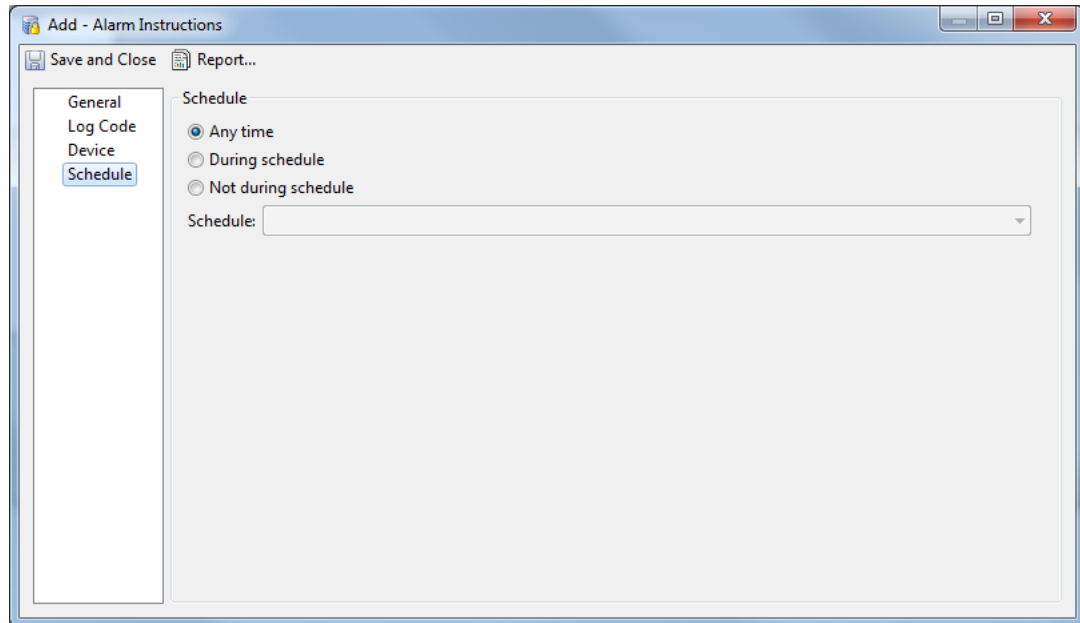

The fields available on this page include:

Table 12-6 Fields on the Schedule page of the Add Alarm Instructions dialog

Field	Description
Any time	Select this radio button if this instruction set should apply at any time. This is the default selection.
During schedule	<p>Select this radio button to specify a defined schedule during which this instruction set applies.</p> <p>The Schedule field is activated. Select from one of the existing schedules.</p>

Table 12-6 Fields on the Schedule page of the Add Alarm Instructions dialog (continued)

Field	Description
<b>Not during schedule</b>	Select this radio button to specify that this instruction set is not active during the designated schedule.  The Schedule field is activated. Select from one of the existing schedules.
<b>Schedule</b>	If the 'During schedule' or 'Not during schedule' option is selected, this field is activated.  Click to select an existing schedule from the drop-down list.  Only those schedules previously defined for this system appear in this option list. To create new schedules, refer to <a href="#">Using the Schedule Manager, page 11-9</a> .

### Alarm Instructions - Viewing

To view existing alarm instructions:

- 
- Step 1** In the **Alarms** main window, right click on the alarm to investigate, and choose the **View** command from the pop-up menu, as specified in [Viewing Alarms, page 12-8](#).  
The Alarm Detail window appears, as explained in [Alarm Detail Window, page 12-10](#).
- Step 2** Click the **Instructions** button.  
Note that the Instructions button is only active if instructions have been specified for this alarm. For more about defining alarm instructions, refer to [Alarm Instructions - Creating, page 12-13](#).
- Step 3** On the resulting instructions dialog, read the provided instructions, and perform the specified actions.
- Step 4** When you are finished, click **OK** to close this dialog.
-

## Viewing Audit Trail Records

Audit trail records are events caused when an operator modifies a record, such as a badge or personnel record. Audit trail records include the user who performed the action, the date, the time, and the state of the object before and after the edit. To view audit trail records, do the following:

**Step 1** Select **Audit Trail** from the Reports menu.

The **Audit Trail** main window (Figure 12-10) shows the most recent audit records.

**Figure 12-10** *Audit Trail main window*

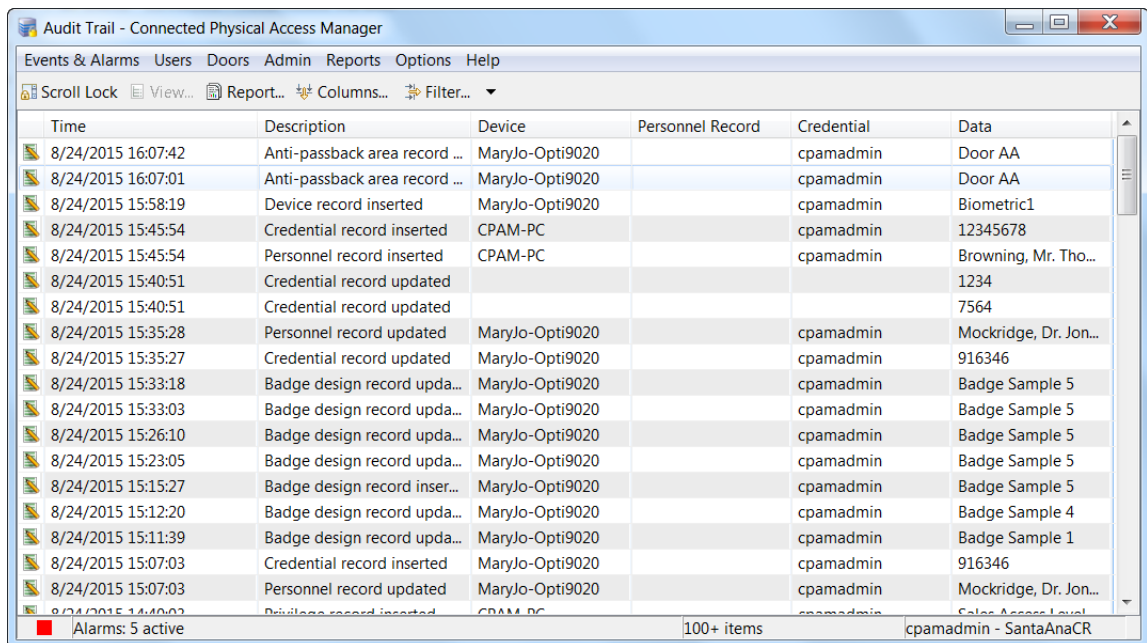

The screenshot shows the 'Audit Trail - Connected Physical Access Manager' window. The window title bar includes 'Events & Alarms', 'Users', 'Doors', 'Admin', 'Reports', 'Options', and 'Help'. Below the title bar is a toolbar with 'Scroll Lock', 'View...', 'Report...', 'Columns...', and 'Filter...' buttons. The main area is a table with the following columns: Time, Description, Device, Personnel Record, Credential, and Data. The table contains 20 rows of audit records, with the most recent at the top. The status bar at the bottom shows 'Alarms: 5 active', '100+ items', and 'cpamadmin - SantaAnaCR'.

Time	Description	Device	Personnel Record	Credential	Data
8/24/2015 16:07:42	Anti-passback area record ...	MaryJo-Opti9020		cpamadmin	Door AA
8/24/2015 16:07:01	Anti-passback area record ...	MaryJo-Opti9020		cpamadmin	Door AA
8/24/2015 15:58:19	Device record inserted	MaryJo-Opti9020		cpamadmin	Biometric1
8/24/2015 15:45:54	Credential record inserted	CPAM-PC		cpamadmin	12345678
8/24/2015 15:45:54	Personnel record inserted	CPAM-PC		cpamadmin	Browning, Mr. Tho...
8/24/2015 15:40:51	Credential record updated				1234
8/24/2015 15:40:51	Credential record updated				7564
8/24/2015 15:35:28	Personnel record updated	MaryJo-Opti9020		cpamadmin	Mockridge, Dr. Jon...
8/24/2015 15:35:27	Credential record updated	MaryJo-Opti9020		cpamadmin	916346
8/24/2015 15:33:18	Badge design record upda...	MaryJo-Opti9020		cpamadmin	Badge Sample 5
8/24/2015 15:33:03	Badge design record upda...	MaryJo-Opti9020		cpamadmin	Badge Sample 5
8/24/2015 15:26:10	Badge design record upda...	MaryJo-Opti9020		cpamadmin	Badge Sample 5
8/24/2015 15:23:05	Badge design record upda...	MaryJo-Opti9020		cpamadmin	Badge Sample 5
8/24/2015 15:15:27	Badge design record inser...	MaryJo-Opti9020		cpamadmin	Badge Sample 5
8/24/2015 15:12:20	Badge design record upda...	MaryJo-Opti9020		cpamadmin	Badge Sample 4
8/24/2015 15:11:39	Badge design record upda...	MaryJo-Opti9020		cpamadmin	Badge Sample 1
8/24/2015 15:07:03	Credential record inserted	MaryJo-Opti9020		cpamadmin	916346
8/24/2015 15:07:03	Personnel record updated	MaryJo-Opti9020		cpamadmin	Mockridge, Dr. Jon...
8/24/2015 14:40:03	Privilege record inserted	CPAM-PC		cpamadmin	Sales Access Level

**Step 2** Modify the list of records using the following toolbar controls:

- **Scroll Lock:** Disable or enable automatic scrolling of the list as new audit records are inserted.
- **Report...:** See [Creating Reports](#), page 3-10.
- **Columns...:** See [Revising the Column Display](#), page 3-14.
- **Filter:** See [Using Filters](#), page 3-12.

**Step 3** Select a record and click **View...** to open the detail window (Figure 12-11). You can also double-click the record.

**Step 4** Review the properties and actions for the record. See [Table 12-7](#) for field descriptions.



Figure 12-11 View Audit Record detail window

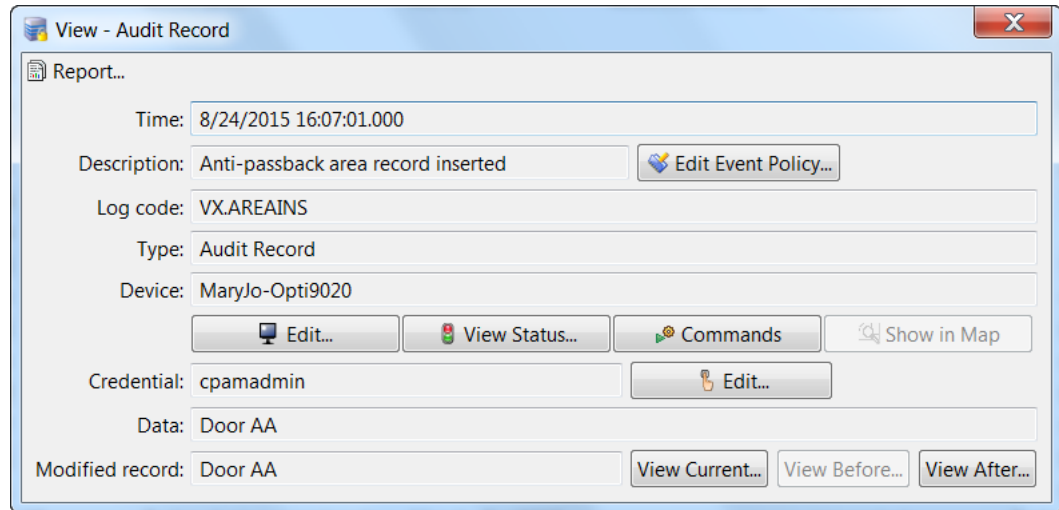

Table 12-7 Fields on the View Audit Record dialog

Field	Description
<b>Time</b>	The time the event was received and stored in the database. If the event was processed by an external device such as a controller, this may differ from the time, depending on delays or interruptions in communications between the host and the device.
<b>Description</b>	A description of the event.
<b>Site</b>	A site is a single instance of an ICPAM database.
<b>Log Code</b>	The internal code to identify the event. Log codes can be viewed in the <b>Event Policy Manager</b> and defined as alarms. See <a href="#">Modifying Default Event Policies, page 12-37</a> .
<b>Type</b>	The type of event. The types of events are: <ul style="list-style-type: none"> <li>• <b>Event:</b> A general occurrence within the system, often from external hardware such as a controller.</li> <li>• <b>Alarm:</b> An event configured to be an alarm.</li> <li>• <b>Alarm Annotation:</b> An event caused by commenting, clearing, or acknowledging alarms.</li> <li>• <b>Audit Record:</b> An event caused by an operator modifying a record, such as a badge or personnel record.</li> <li>• <b>Device Command:</b> An event caused by an operator executing a device command.</li> <li>• <b>Device Command Result:</b> Notification of a completed device command.</li> </ul>
<b>Priority</b>	The importance level assigned to the event. Priorities range from a low of -10 to a high of 10. To configure these priorities, see <a href="#">Setting Event and Alarm Priorities, page 12-47</a> .

Table 12-7 Fields on the View Audit Record dialog (continued)

Field	Description
<b>Device</b>	<p>The device associated with the event, such as a workstation or hardware module.</p> <ul style="list-style-type: none"> <li>• <b>Edit...:</b> Displays information about the device including type, name, and address. Some fields are editable, depending on the type of device.</li> <li>• <b>View Status...:</b> Displays the status of the associated device. For example, if the workstation is logged in to the system or if the hardware module is enabled.</li> <li>• <b>Commands:</b> lists any available commands for the device. For example, apply a controller configuration, or send a message to a workstation.</li> <li>• <b>Show in Graphics Map:</b> see <a href="#">Maps Viewer, page 12-50</a>.</li> </ul>
<b>Credential</b>	<p>If the event has an associated credential (such as a badge or login), the identifying information of the credential (such as a card or username) is displayed in this field.</p> <ul style="list-style-type: none"> <li>• <b>Edit...:</b> Revise the credential (badge, login, etc.) record associated with the event.</li> </ul>
<b>Watch Level</b>	<p>Displays the Credential Watch Level for the badge associated with the event. See <a href="#">Adding a Color Border to Event Photos (Credential Watch), page 12-25</a>.</p> <ul style="list-style-type: none"> <li>• <b>Edit...:</b> Revise the credential watch level associated with the badge.</li> </ul>
<b>Personnel Record</b>	<p>If a personnel record is associated with the event, this field displays the person's name.</p> <ul style="list-style-type: none"> <li>• <b>Edit...:</b> Edit the personnel record associated with the event.</li> <li>• <b>View Photo...:</b> Displays the associated personnel record photo, if any.</li> </ul>
<b>Data</b>	<p>This field displays detailed information about the event, the exact value and meaning of which depends on the type of event. This field is generally for advanced or troubleshooting use. If the event is associated with an attempt to gain access to an access point using a badge that is not in the database, then this field contains the card number.</p>
<b>Modified Record</b>	<p>The item changed by the user.</p> <ul style="list-style-type: none"> <li>• <b>View Current...:</b> Opens a detail window of the modified record, as it exists currently.</li> <li>• <b>View Before...:</b> Opens a detail window of the modified record, as it existed before the modification.</li> <li>• <b>View After...:</b> Opens a detail window of the modified record, as it existed after the modification.</li> </ul>

## Viewing Recent Events for a Device, Driver, or Location

To view a list of the recent events for a device or driver, do the following:

- Step 1** Select **Hardware - Tree** or **Door/Location-based Hardware** from the **Doors** menu.
- Step 2** (Optional) Use the items on the toolbar to filter or search the entries. See [Toolbar Features, page 3-10](#).
- Step 3** Right-click on the device or driver, and choose **View Recent Events** from the pop-up menu, as shown in [Figure 12-12](#).

**Figure 12-12** *View Recent Events command*

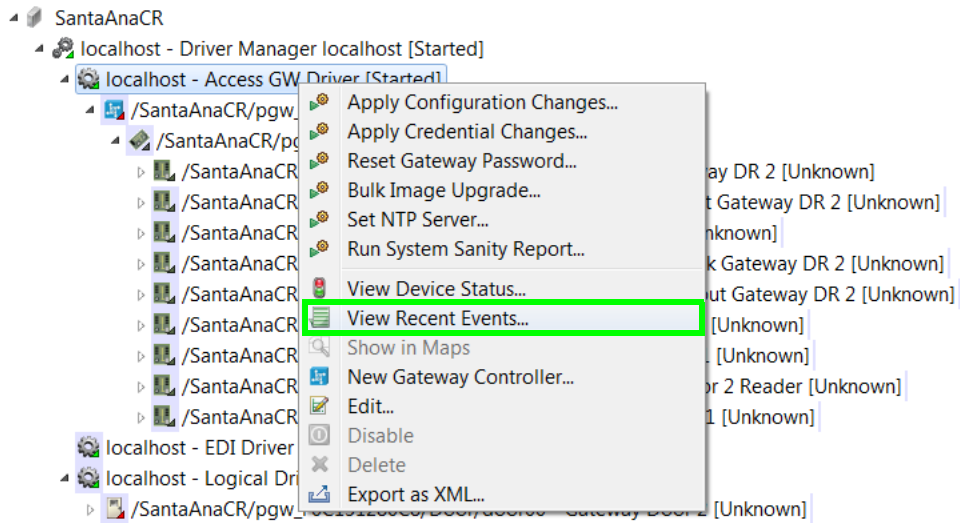

The resulting window displays a summary of the recent events, as shown in [Figure 12-13](#).

**Figure 12-13** *Recent Events*

The screenshot shows a window titled 'Access GW Driver - Recent Events'. It contains a table with the following data:

Time	Description	Device	Personnel Record	Credential	Data
8/19/2015 11:39:37	Gateway Driver: Started	Access GW Driver			
8/19/2015 11:39:37	Gateway Driver: Starting	Access GW Driver			
8/19/2015 11:38:57	Gateway Driver: Stopped	Access GW Driver			
8/19/2015 11:38:57	Gateway Driver: Stopping	Access GW Driver			
8/19/2015 09:45:55	Configuration download t...	Access GW Driver			Gateway Serial No : F0C151280B6 Res...
8/19/2015 09:45:49	Configuration download t...	Access GW Driver			Gateway Serial No : F0C151280C8 Res...
8/18/2015 15:32:55	Gateway Driver: Started	Access GW Driver			
8/18/2015 15:32:55	Gateway Driver: Starting	Access GW Driver			
8/18/2015 15:32:18	Gateway Driver: Stopped	Access GW Driver			
8/18/2015 15:32:18	Gateway Driver: Stopping	Access GW Driver			

At the bottom of the window, it indicates '10+ items'.

- Step 4** Double-click on an event to view its details.

## Viewing Events Using Personnel Photos

Use the **Event Photos** module to display events using personnel photos.

This section includes the following:

- [Viewing Event Photos](#), page 12-24
- [Adding a Color Border to Event Photos \(Credential Watch\)](#), page 12-25
- [Using Filters to Limit the Photos and Doors Events Displayed by Event Photos](#), page 12-29

### Viewing Event Photos

**Event Photos** displays events along with a personnel photo and other information in real-time.

- 
- Step 1** Select **Event Photos** in the **Events & Alarms** menu, in the **Monitoring** submenu.
- Step 2** Select a photo to display for the associated event ([Figure 12-14](#)).

*Figure 12-14 Event Photos Window*

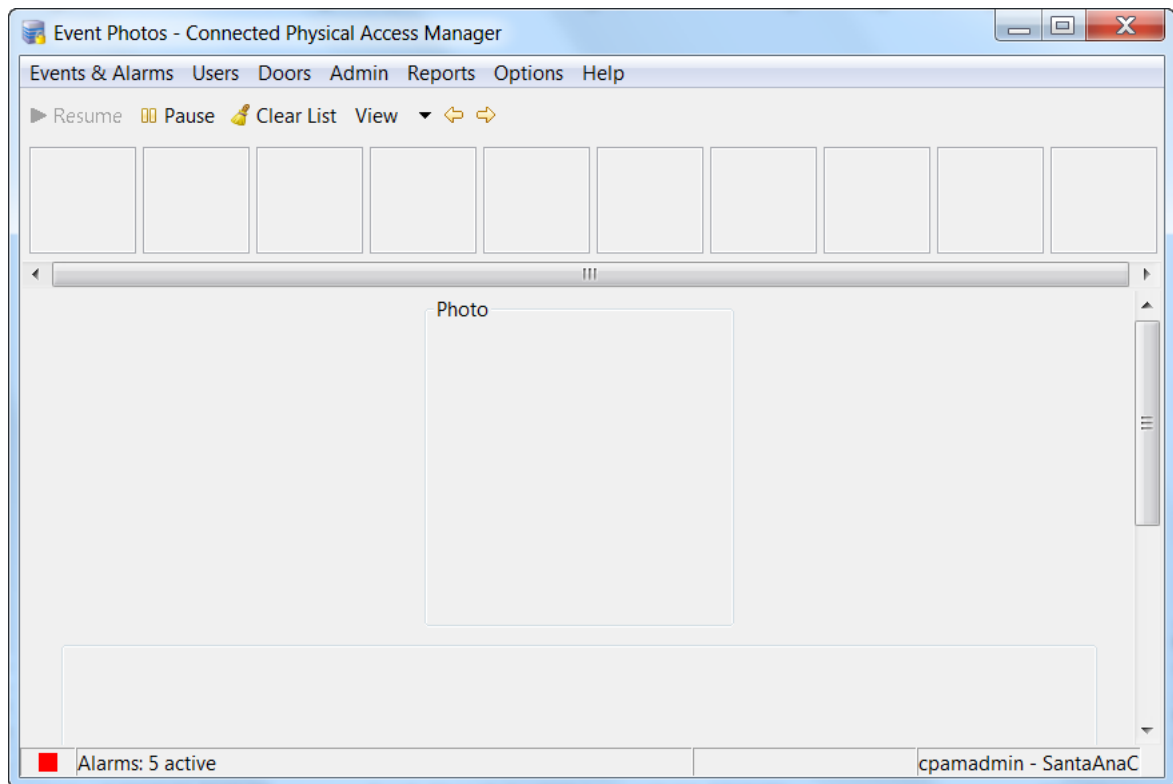

**Note** The screen appears blank (without fields or data) until a photo event is available for display.

- Step 3** From this main window, you can perform the following actions:
- **Filter:** Filter to display specific types of events (see [Using Filters](#), page 3-12 and [Using Filters to Limit the Photos and Doors Events Displayed by Event Photos](#), page 12-29).

- **View:** Select the type of display preferred for viewing event photos. Options include:
  - **Scroll Photos From:** In a left to right layout the most recent event is displayed at the right of the screen. The opposite is true for right to left.
  - **Show Event Detail Buttons:** Displays the buttons in the detail area.
  - **Max Photos:** Defines the number of most recent photos to display in the window.
- **Resume:** Resume the scrolling of new events.
- **Pause:** Pause the scrolling of new events.

**Tip**

See [Viewing Events, Alarms, and Audit Trail Records, page 12-2](#) for field descriptions. To make the event fields read-only, see [Configuring Events and Alarms, page 12-37](#).

## Adding a Color Border to Event Photos (Credential Watch)

The Credential Watch feature enables you to display event photos with a colored border, to provide additional information regarding the status of the badge holder.

For example, if a guard uses Event Photos to view photos of the people accessing a door, a colored border can visually signify if the user is a contractor, visitor, etc.

The default credential watch levels are:

- Low: a yellow border around the photo.
- Medium: an orange border around the photo.
- High: a red border around the photo.

You can modify these definitions, or create custom watch levels. For example, if the badge holder has been employed less than one year, an ORANGE border may appear around the photo. If the badge holder is a contractor, a RED border may appear around the photo.

To configure Credential Watch, do the following:

- 
- Step 1** Enable the Credential Watch Levels menu:
- a. Choose **System Configuration** from the Admin menu.
  - b. Choose the **Miscellaneous** tab.

- c. Select the **Enable credential watch levels** check box.

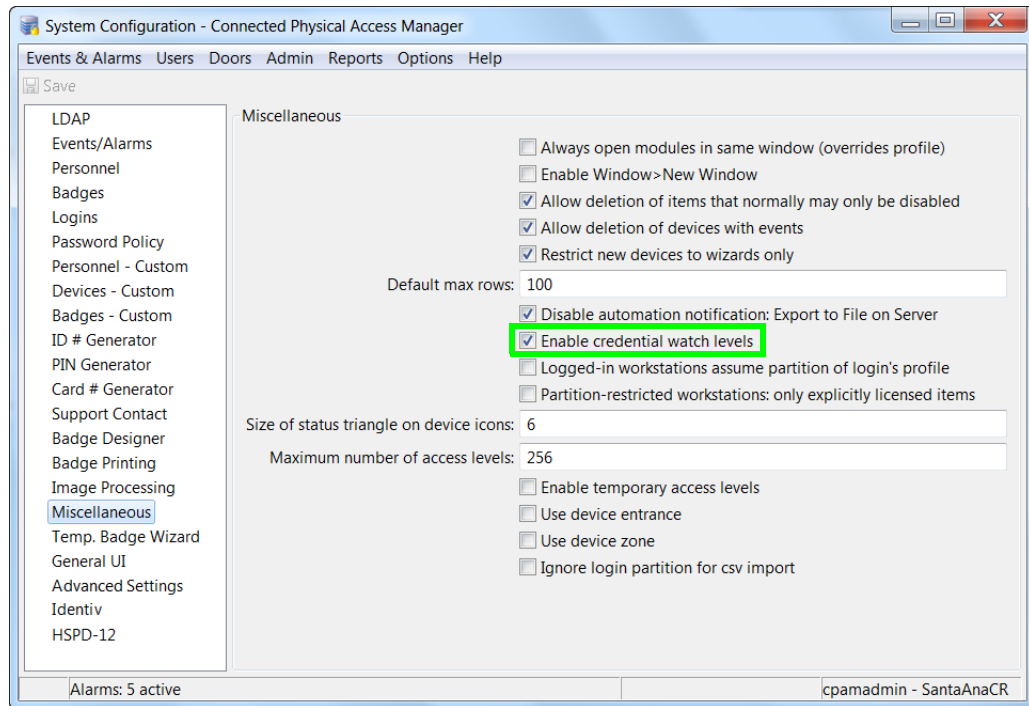

- d. Click **Save**.
- e. Log out and log back in to the ICPAM application to activate the changes (select **Logout** from the **Options** menu).

**Step 2** Add credential watch access privileges for user profiles:

- a. Select **Profiles** from the **Users** menu.
- b. Click **Add**, or select an existing profile and click **Edit**.
- c. Click the **Modules** tab.

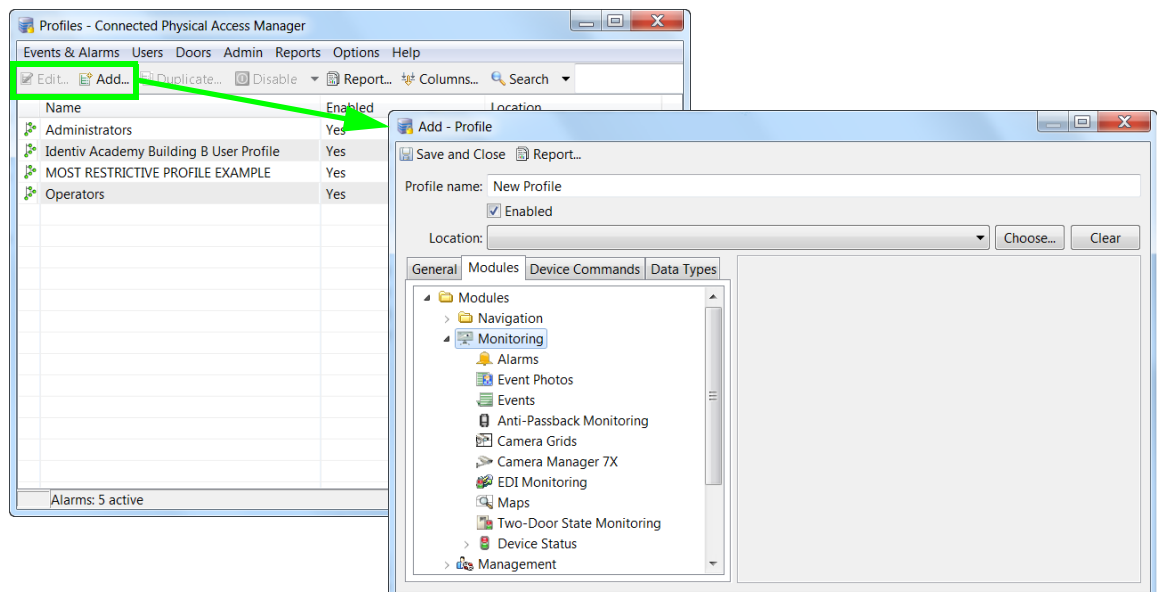

- d. Click the **Quick Launch** module in the left window.
- e. Select the options in the panel to the right.
- f. Click **Save and Close**.



**Tip** For more information, see [Chapter 4, “Configuring User Access for the ICPAM Desktop Client”](#).

**Step 3** (Optional) Assign the profile to the user login, if necessary:

- a. Select **Login** from the **Users** menu.
- b. Click **Add**, or select an existing user and click **Edit**.
- c. Select **Profiles**.
- d. Select the profile that includes the required access privileges.
- e. Click **Save and Close**.

**Step 4** (Optional) Create or edit the credential watch definitions, to specify the photo border color and description.

- a. Select **Credential Watch Levels** from the Admin module.
- b. Click **Add**, or select an existing level and click **Edit**.

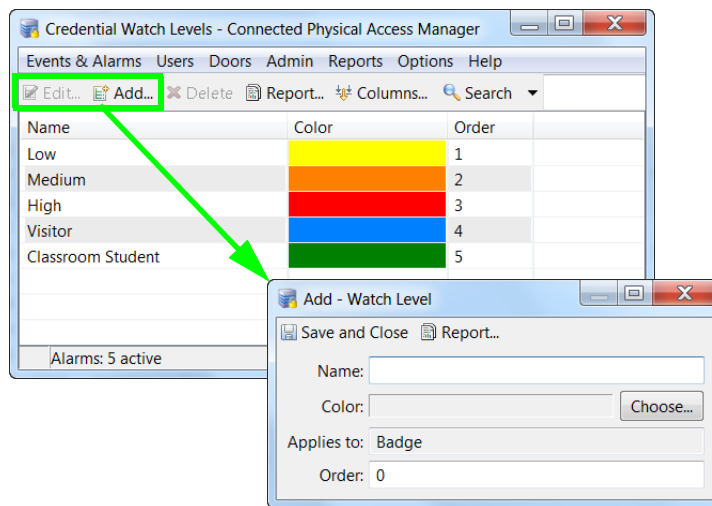

- c. Enter the **Name** of the level. For example: New Employee.
- d. Enter the **Order** number of the level to define the hierarchy of the levels. For example, enter 0 to display the new level at the top of the list. This can also define the relative importance or severity of the levels.
- e. Click **Choose** to select a border color for the photos when using **Event Photos**.
- f. Click **Save and Close**.

**Step 5** Add the credential watch level to a badge configuration:

- a. Select **Badges** from the Admin module.

- b. Click **Add**, or select an existing badge and click **Edit**.

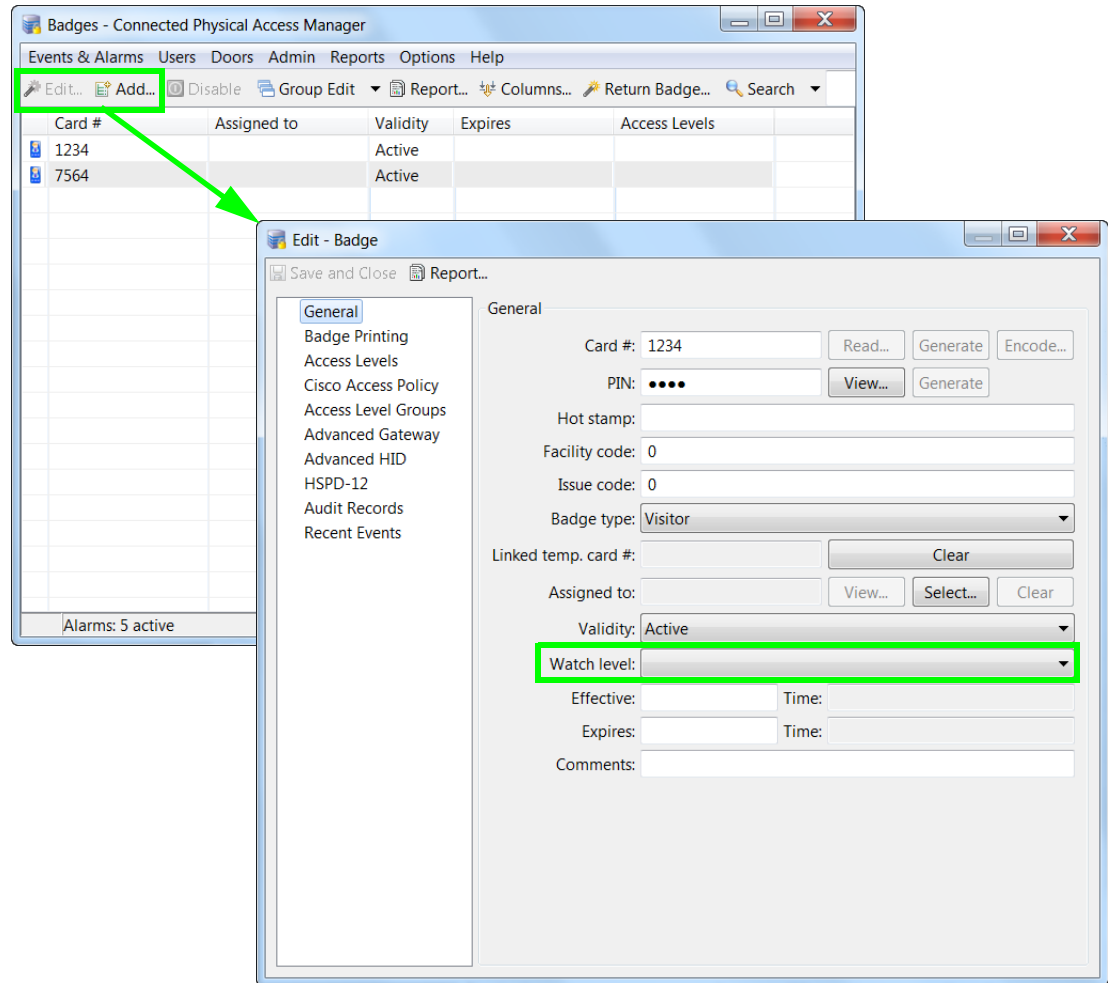

- c. Select the **General** tab.

- d. Select the **Watch level** from the drop-down list. For example, **New Employee**.

**Step 6** Open the **Event Photos** module: select **Event Photos** from the Events & Alarms menu, in the **Monitoring** submenu.

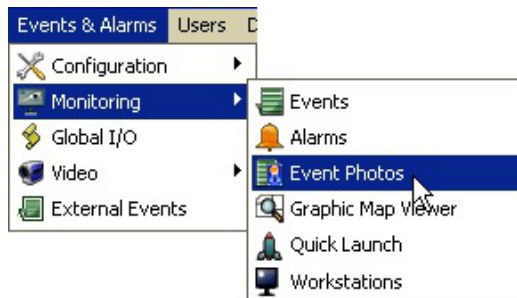



- Step 7** Present the badge to the door card reader to display the associated badge photo in Event Photos. In this example, a dark blue border is displayed and the watch level is “New Employee”.

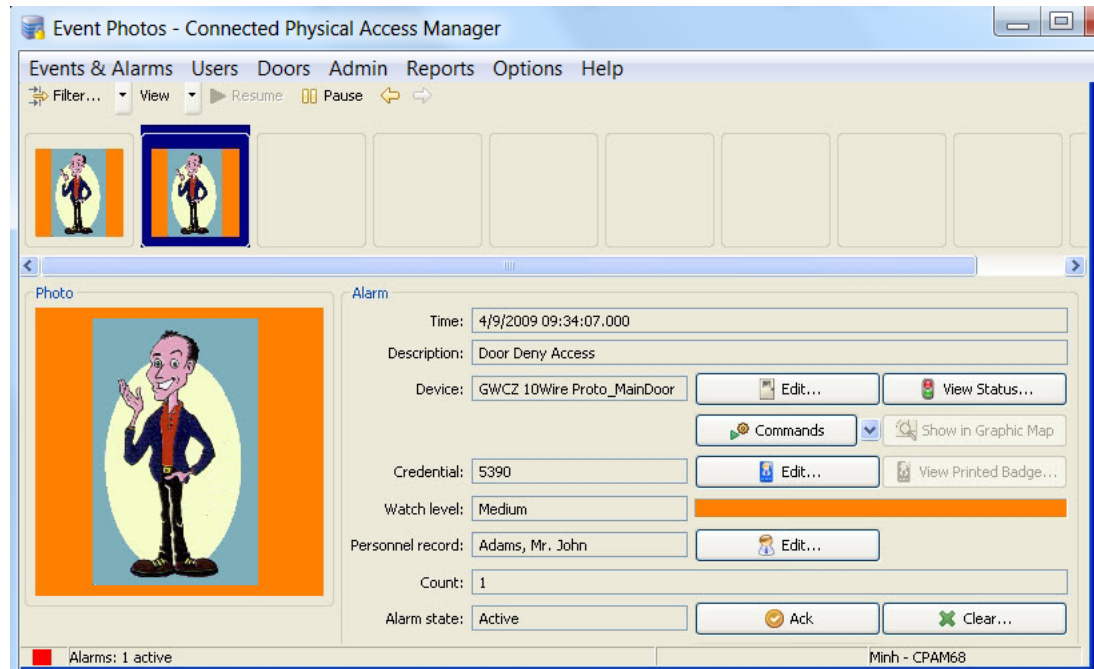

**Note** The screen appears blank (without fields or data) until a photo event is available for display.

## Using Filters to Limit the Photos and Doors Events Displayed by Event Photos

By default, **Event Photos** displays the photos and events for any badge presented to any door on the system. Use the Filter to display only events for a specific door or set of doors. For example, the guard at the front entrance should only see the event photos for badges presented at that particular door.

In addition, the photo associated with a badge is shown two times by default: one time when the credential is read, and one time for the Grant Access event. Use Filters to only display the photo once.

Complete the following instructions to limit the doors and photos displayed by Event Photos:

- Step 1** To select specific doors to display event information:
- Select **Edit Filter** from the Filters toolbar menu.
  - In the filter window, select the **Device** tab, then click on the **Choose** button on the right side of the Device field (see [Figure 12-15](#)).
  - Select the doors or devices that will display events in Event Photos.
  - Click **OK** to close the Choose Devices window.
  - Click **OK** to close the Filter window and save the changes.

Figure 12-15 Filter Event window - Device page, to Choose Devices dialog

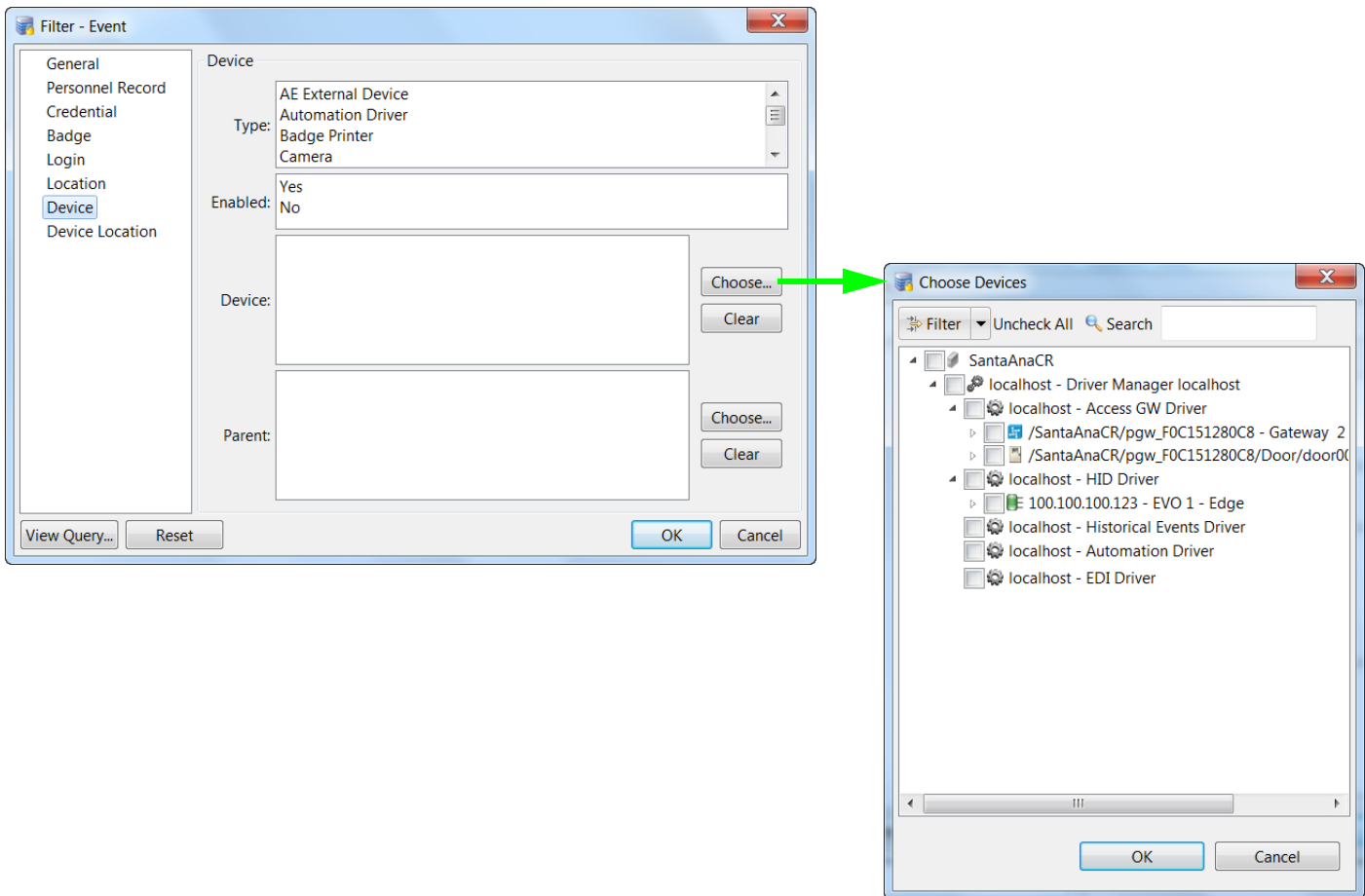

- Step 2** To display the photo once for each badge presentation:
- a. In the filter window, select the **General** tab, then click on the **Choose** button on the right side of the Device field (see [Figure 12-16](#)).

Figure 12-16 Filter Log Code window - General page, to Choose Log Code dialog

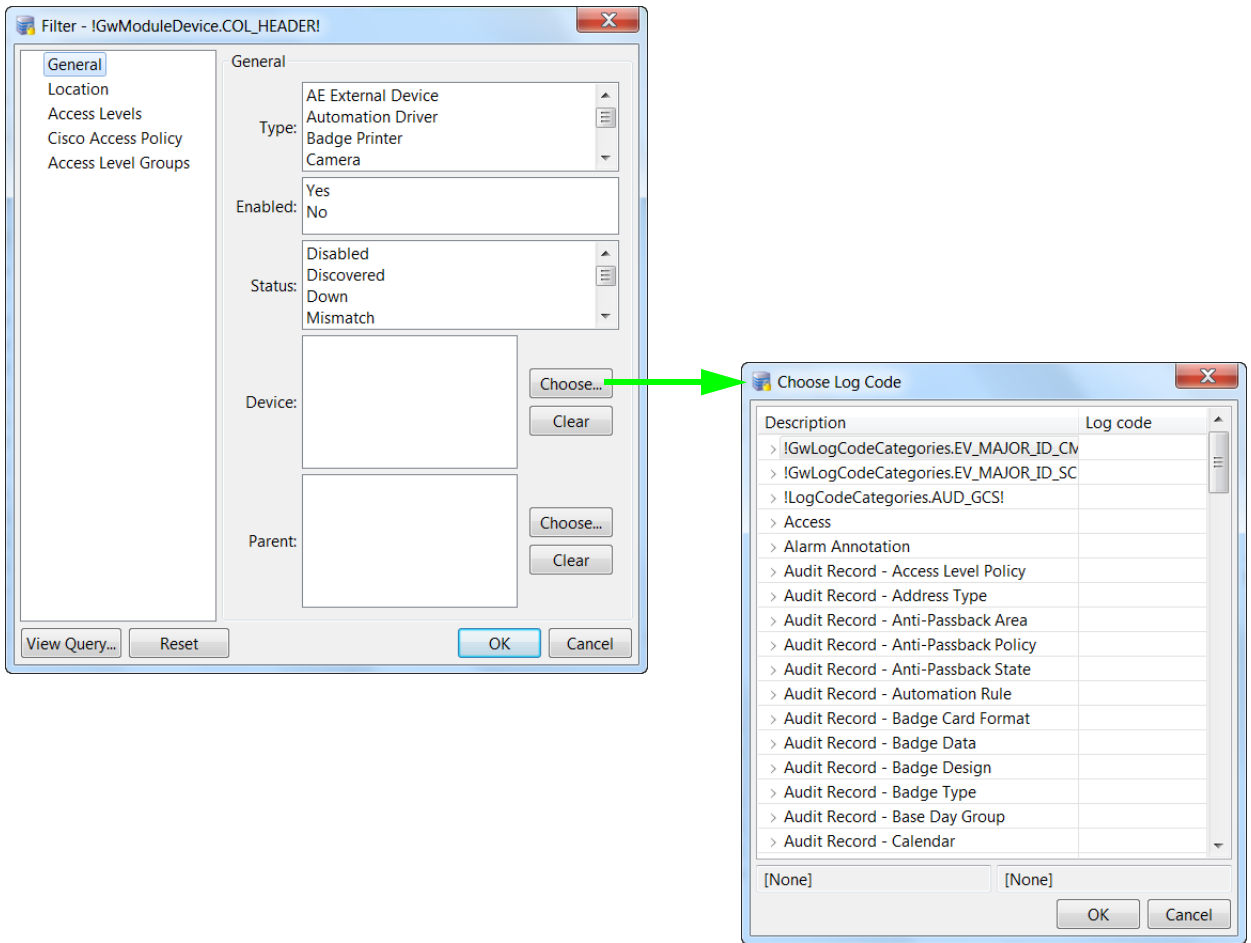

- b. Select the events to be displayed in Event Photos, as shown in [Figure 12-17](#). For example, select **Door Grant Access**.

*Figure 12-17 Select the Log Code*

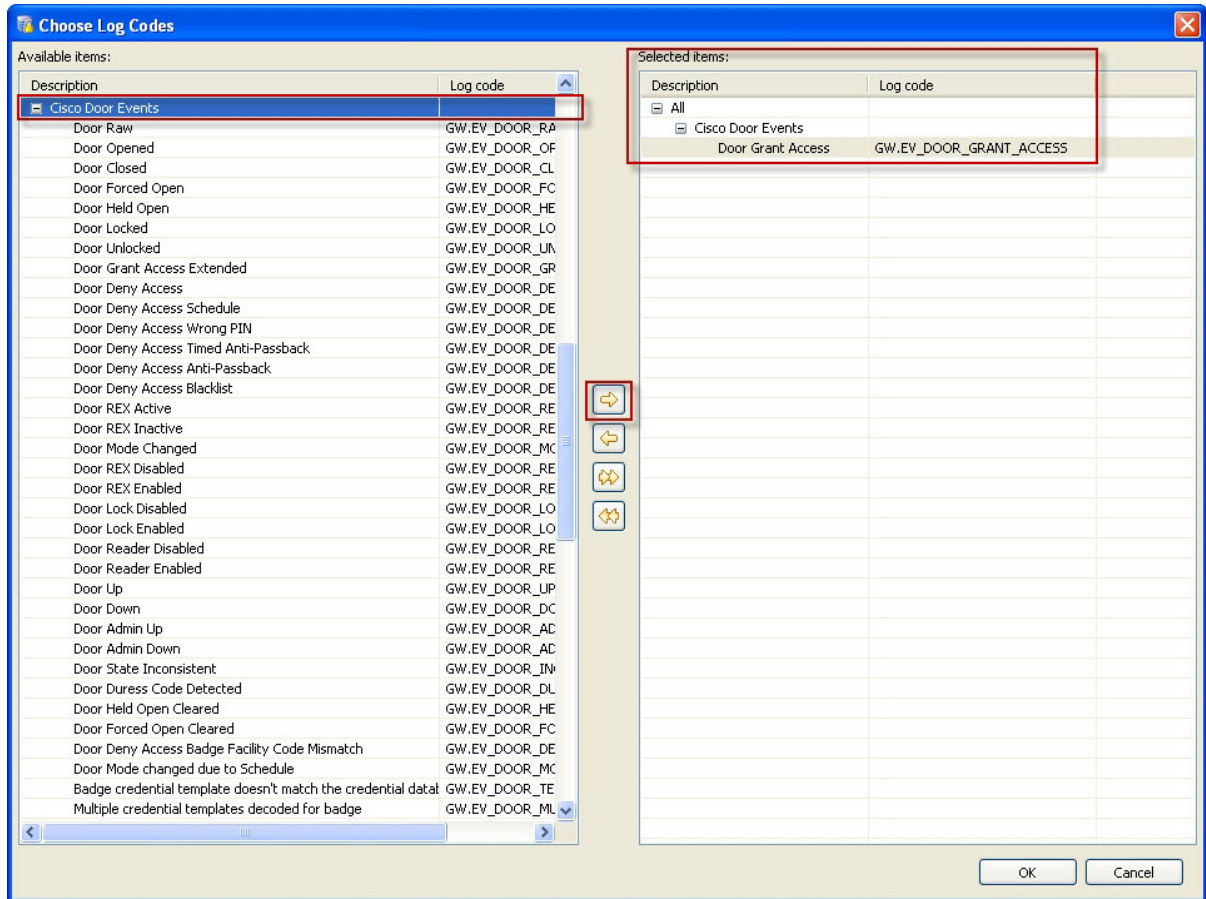

- c. Click **OK** to close the windows and save the changes.

# Recording External Events

External applications can record events in ICPAM using the **recordExtEvent** API. After being recorded, those events are displayed in the Events & Alarms Monitoring modules. External Event Types are defined using the Event Definition Format, and imported using the steps described in the following topics.

To record events from external applications, do the following:

1. [Define External Event Types Using the Event Definition Format, page 12-33](#). This file also defines the categories for the log codes.
2. [Create a Text File to Define the Event Names in ICPAM, page 12-34](#).
3. [Import the Files into ICPAM, page 12-34](#).
4. Add external events and alarms to ICPAM using the **recordExtEvent** API, as described in the *Cisco Physical Access Control API Reference Guide*.

## Define External Event Types Using the Event Definition Format

Use the Event Definition Format to create an XML file that defines the event and alarm codes used to add external events to ICPAM. This file also defines the category for the events and is imported into ICPAM to create the codes.

### Example

In the following XML example:

- The concatenation rule is: AE.<logcode\_prefix>\_<logcode>
- Event category: AE.Cisco\_VSM
- The log codes for the category are: AE.VS\_VSM\_Sample1 and AE.VS\_VSM\_Sample2

```
<appext_eventdefns
  xmlns:xsi="http://www.w3.org/2001/XMLSchema-instance">
  <appext_entry appname="Cisco_VSM" logcode_prefix="VS">
    <ext_event_defn logcode="VSM_Sample1"
      priority="10"
      description="VSM Sample Event-1"/>
    <ext_event_defn logcode="VSM_Sample2"
      priority="10"
      description="VSM Sample Event-2"
      isAlarm="true"/>
  </appext_entry>
</appext_eventdefns>
```

The file is saved with the .xml extension. For example: SampleExtEventDefns.xml.

## Create a Text File to Define the Event Names in ICPAM

To define the log code names displayed in ICPAM, create a text file that defines a string name for each event and the event category.

In the following example, the string name for the two events and the event category are defined:

```
VS_VSM_Sample1=Sample Event-1
VS_VSM_Sample2=Sample Event-2
Cisco_VSM=Cisco Video Surveillance Manager
```

The file is saved with the `.properties` extension. For example: `AppExtMessages.properties`.

## Import the Files into ICPAM

After the XML and properties files have been created, import the files into the ICPAM External Events module.

**Step 1** Select **External Events** from the **Events & Alarms** menu.

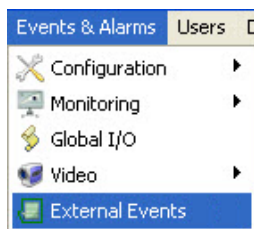

**Step 2** Click **Import**.

**Step 3** On the resulting window, do the following:

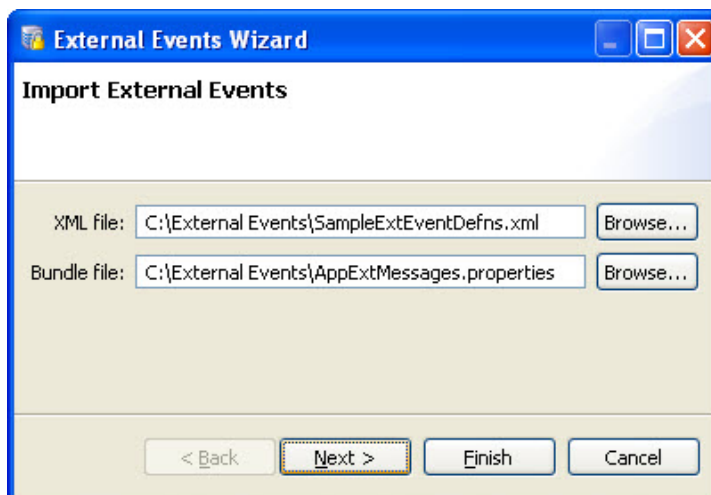

- a. Select the XML and Properties files.
  - The XML file defines the event log codes and category for the external events.
  - The Properties file defines the text string for each code and category. The text string is the name that appears in ICPAM.

b. Click **Next** to preview the settings, or click **Finish** to save the changes.

For instructions about how to create these files, see:

- [Define External Event Types Using the Event Definition Format](#), page 12-33
- [Create a Text File to Define the Event Names in ICPAM](#), page 12-34

**Step 4** (Optional) Preview the settings.

**Step 5** Click **Finish** to save the changes

**Step 6** Click **Back** to select a different file.

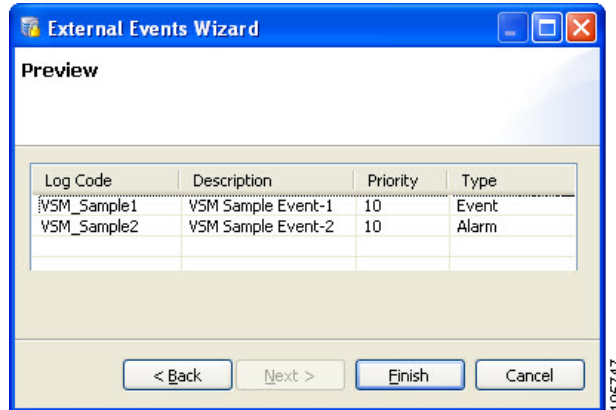

**Step 7** The new log codes are displayed in the **External Events** main window.

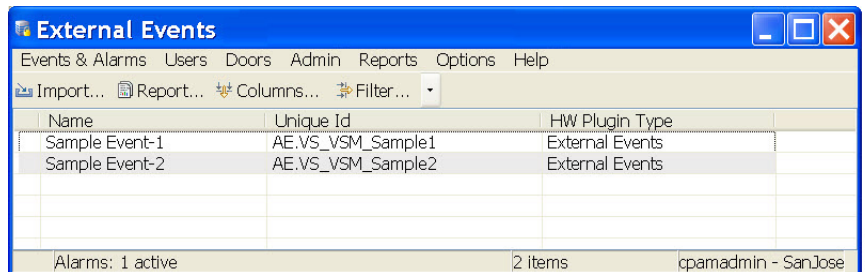

**Step 8** Add external events and alarms to ICPAM using the **recordExtEvent** API, as described in the *Cisco Physical Access Control API Reference Guide*.

## Viewing Workstation Activity

To view a summary of the users who access the system, select **Workstations** from the **Events & Alarms** menu, under the **Monitoring** submenu. The Workstations window (see [Figure 12-18](#)) shows the most recent events in the access-control system.

*Figure 12-18 Workstation Status main window*

Name	Status	Type	Model	Parent	Address	Enabled	Top Alar...
CPAM-PC	Logged ...	Worksta...			100.100...	Yes	
MaryJo-Opti9020	Logged ...	Worksta...			100.100...	Yes	



**Tip**

To view additional details, such as the credentials and connected time, double-click a workstation's Name.



# Configuring Events and Alarms

This section includes instructions to customize the behavior of system events. For example, you can treat an event as an alarm, suppress recording, set the event priority, define the sound played for an alarm, and other settings.

**Note**

---

Event policies are executed only on the ICPAM server.

---

This section also includes instructions to limit the type of events seen by users, and configure the Alarms module to automatically open when an alarm occurs.

## Contents

- [Modifying Default Event Policies, page 12-37](#)
- [Event Policy Manager in ICPAM 2.1, page 12-38](#)
- [Automatically Open the Alarms Window, page 12-42](#)
- [Configuring Alert Sounds, page 12-46](#)
- [Setting Event and Alarm Priorities, page 12-47](#)
- [Defining User Privileges for Editing Events, page 12-48](#)

**Tip**

---

To automatically trigger actions when an event occurs, see [Chapter 13, “Configuring Automated Tasks”](#).

---

## Modifying Default Event Policies

Each event or alarm record includes a log code that defines the event type and actions associated with the event. The built-in event policies define inherent system behavior, such as which events are also alarms, and which events are recorded to the database (all built-in events are recorded to the database by default). These built-in policies are based on the *log code* only: no other criteria are used to define the event trigger.

The default event policies should be changed only if you need to change an inherent event behavior. For example:

- Whether the event is an alarm or an event.
- Whether the event is saved to the database.
- The event priority.
- The sound played when the event is triggered.
- The color shown for the event in the event modules.

When custom events are required, we recommend creating a custom event policy, as described in the following section.

## Configuring Custom Event Policies

Event policies can be configured to trigger events and alarms based on one or more conditions, such as the event type, the source device, device type, location, time of occurrence, or other factors.

- If an event policy includes more than one condition, all the conditions must match for the event to be triggered.
- If multiple events apply to an event occurrence, the most specific event policy is executed. Since only one event policy can be triggered for any event, only the most specific event is used. To determine the most specific event, the following criteria are applied in decreasing order (the criteria at the top of the list are given greater importance):
  - a. Log code
  - b. Log code category
  - c. Device instance
  - d. Device group
  - e. Partition
  - f. Hierarchical location (Building, Area, etc.)
  - g. Device type
  - h. Time schedule
  - i. Invert time schedule (That is, “Not in” time schedule)

### Examples

- If one event policy is based on a log code (such as Door Forced Open) and a second event policy uses the same log code in combination with other criteria (such as Time schedule), then the second event policy is selected.
- If one event policy is based on a device type, and a second is based on a device instance, then the device instance event prevails since it is higher in the list of criteria.
- If two event policies are based on the same time schedule, but the first event defines **During time schedule** and the second event defines **Not during time schedule**, the first one event policy is used since **During time schedule** is higher in the list.
- If one event policy is based on a log code and a second policy is based on a collection of log codes and a location, all events in that location will use the second policy. Events from other locations will use the first policy.

## Event Policy Manager in ICPAM 2.1

If the profile enhancement feature is set in the system configuration settings (see [Logins page of the System Configuration window, page 17-11](#) for more information on this), you need to remember the following points while creating/editing event policies:

- A location-restricted user will not be able to edit default event policy rules.
- When a location-restricted user creates a new rule, by default the Hierarchical location field is auto-populated.
- The new rule will be applied only to devices belonging to the user’s location.
- When a location-restricted user creates an event policy it also applies to the unprivileged child locations under the location-restricted user.

- Location-restricted users cannot filter devices of their location while creating an event policy.

**Note**

These points are applicable only when the profile enhancement feature is set on the **Logins** page of the **System Configuration** window (starting with the ICPAM 2.1 release); otherwise, the ICPAM appliance retains its behavior as in the previous version (CPAM 1.5.1).

To modify event policies, do the following:

- Step 1** Select **Event Policy Manager** from the **Events & Alarms** menu, in the **Configuration** submenu. The Event Policies main window (Figure 12-19) shows all event policies defined within the system.

**Figure 12-19** Event Policies main window

Name	Applicability Summary	Result Summary	Applies To PlugIn
	Door Duress Code Detected	Priority 8 ALARM	Cisco Gateway
	Door Forced Open	Priority 8 ALARM	Cisco Gateway
	Door Held Open	Priority 8 ALARM	Cisco Gateway
	Door State Inconsistent	Priority 8 ALARM	Cisco Gateway
	Door Trigger 1 Detected	Priority 8 Event	Cisco Gateway
	Door Trigger 10 Detected	Priority 8 Event	Cisco Gateway
	Door Trigger 11 Detected	Priority 8 Event	Cisco Gateway
	Door Trigger 12 Detected	Priority 8 Event	Cisco Gateway
	Door Trigger 13 Detected	Priority 8 Event	Cisco Gateway
	Door Trigger 14 Detected	Priority 8 Event	Cisco Gateway
	Door Trigger 15 Detected	Priority 8 Event	Cisco Gateway
	Door Trigger 16 Detected	Priority 8 Event	Cisco Gateway
	Door Trigger 17 Detected	Priority 8 Event	Cisco Gateway
	Door Trigger 18 Detected	Priority 8 Event	Cisco Gateway
	Door Trigger 19 Detected	Priority 8 Event	Cisco Gateway
	Door Trigger 2 Detected	Priority 8 Event	Cisco Gateway
	Door Trigger 20 Detected	Priority 8 Event	Cisco Gateway
	Door Trigger 3 Detected	Priority 8 Event	Cisco Gateway
	Door Trigger 4 Detected	Priority 8 Event	Cisco Gateway
	Door Trigger 5 Detected	Priority 8 Event	Cisco Gateway
	Door Trigger 6 Detected	Priority 8 Event	Cisco Gateway
	Door Trigger 7 Detected	Priority 8 Event	Cisco Gateway
	Door Trigger 8 Detected	Priority 8 Event	Cisco Gateway

- Step 2** Modify the events, if necessary:
- Select an existing entry and click **Edit**. The detail window opens, as shown in Figure 12-20. You can also double-click the entry.
  - Click **Add...** to open a detail window (Figure 12-20) where you can add a new event policy.
  - Select an entry and click **Delete** to delete that event policy.

Each field is described in Table 12-8 on page 12-40

Figure 12-20 Event Policy Manager detail window

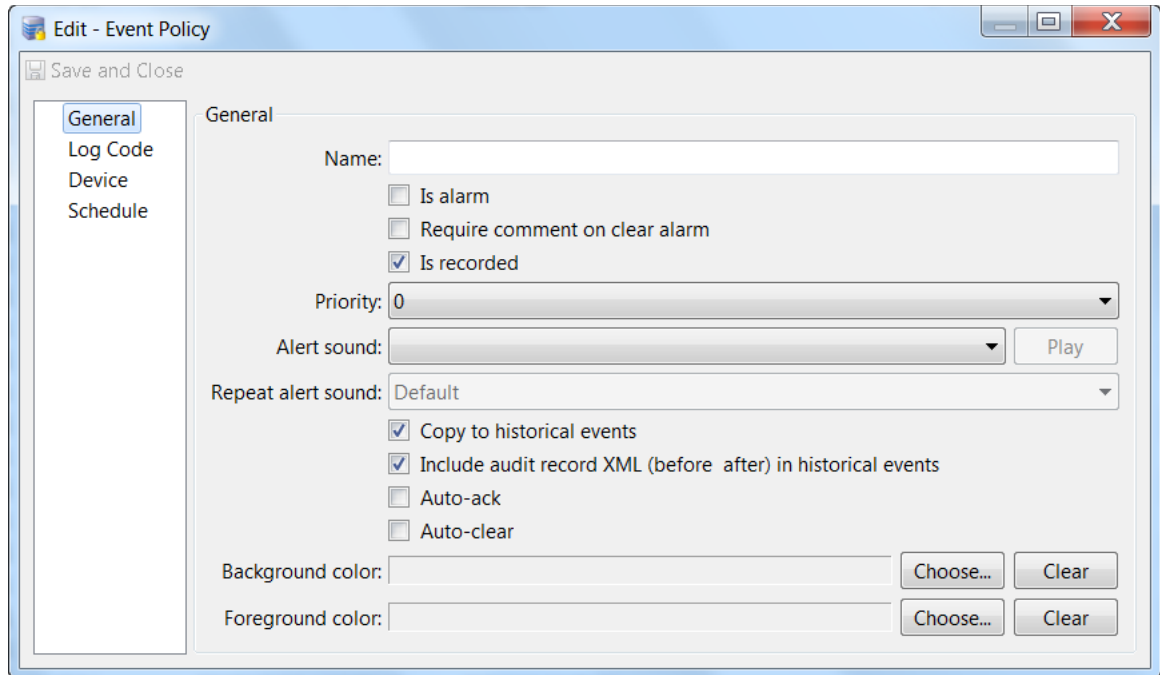

## Event Policy Properties

An event policy has the following properties:

Table 12-8 Event Policy Properties

Field	Description
<b>General page</b>	
<b>Name</b>	The name of this event policy.
<b>Is alarm</b>	Specifies whether events with this log code will be recorded as an alarm, and shown in the <b>Alarms</b> module.
<b>Require comment on clear alarm</b>	
<b>Is recorded</b>	Specifies if events with this log code will be recorded to the database. If unchecked, there is no record of these events occurring. This should only be unchecked by advanced users under the advice of Identiv technical support.
<b>Priority</b>	A priority used for sorting events and alarms. Positive priorities are above normal priority, while negative priorities are below normal priority. Zero is normal.
<b>Alert sound</b>	The sound to be played, if <b>Is Alarm</b> is checked. Available alert sounds are managed in <a href="#">Configuring Alert Sounds, page 12-46</a> . Click <b>Play</b> to preview the alarm sound.

Table 12-8 Event Policy Properties (continued)

Field	Description
Repeat alert sound	
Copy to historical events	
Include audit record XML (before after) in historical events	
Auto-ack	
Auto-clear	
Background color	The color of the event entry. Click <b>Choose</b> to select a color. Click <b>Clear</b> to restore the default white background.
Foreground color	The color of the event text. Click <b>Choose</b> to select a color. Click <b>Clear</b> to restore the default black text.
<b>Log Code page</b>	
Log Code	An abbreviated code uniquely identifying the event.
Log code description	The description associated with the log code.
Applies To	The type of event this log code applies to.
Log code category	The category associated with the log code.
<b>Device page</b>	
Device	If specified, the policy only applies to the device. Click <b>Choose</b> to select the device. Click <b>Clear</b> to remove the device. If no device is specified, the event applies to all devices.
Device Group	If specified, the policy only applies to the device group (for example: <code>Door</code> , <code>Gateway</code> , or <code>Reader</code> ). Click <b>Choose</b> to select the group. Click <b>Clear</b> to remove the group. If no device group is specified, the event applies to all device groups. See also <a href="#">Configuring Device Groups, page 7-24</a> .
Partition	If present, the policy only applies to this partition.
Classification	If present, the policy only applies to this classification.
Anti-passback area	If present, the policy only applies to this anti-passback area.
Anti-passback area (exit)	If present, the policy only applies to this anti-passback area exit.
Entrance	If present, the policy only applies to this entrance.
Zone	If present, the policy only applies to this zone.
Hierarchical location	If present, the policy only applies to the doors in this location.
Device type	If present, the policy only applies to devices of this type.
<b>Schedule page</b>	
Any time	Generate events at all times and dates.
During time schedule	Generate events only during the specified <b>Time schedule</b> .

Table 12-8 Event Policy Properties (continued)

Field	Description
<b>Not during time schedule</b>	Do not generate events during the specified <b>Time schedule</b> . Generate events at all times outside the specified <b>Time schedule</b> .
<b>Time schedule</b>	Specifies the time schedule used for event policies. See <a href="#">Configuring Time Schedules, page 12-43</a> for more information.

## Automatically Open the Alarms Window

To automatically open the Alarms window when an alarm occurs, do the following:

- Step 1** Select **Profiles** from the Users menu.
- Step 2** Click **Add**, or select an existing profile and click **Edit**.
- Step 3** Select the **General** tab, and the submenu **Events/Alarms** (as shown in [Figure 12-21](#)).

Figure 12-21 Edit Profile window - General tab - Events/Alarms page

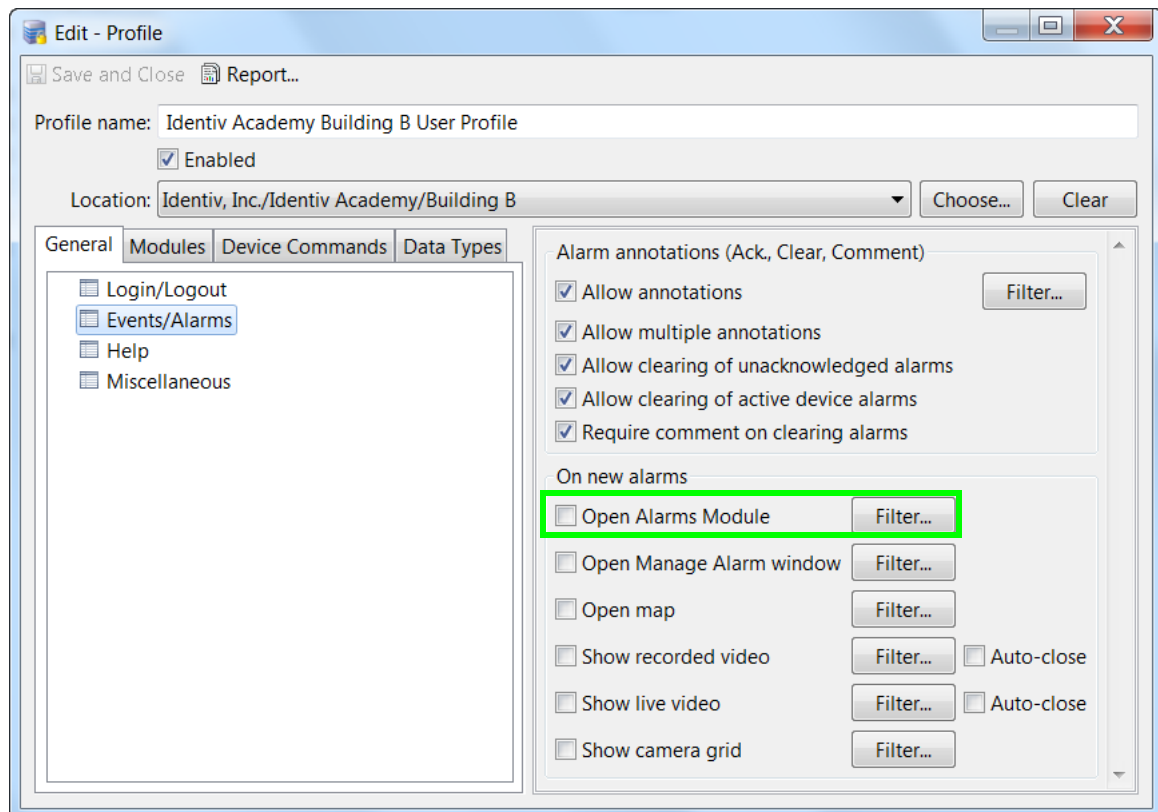

- Step 4** Select the checkbox for **Open Alarms Module**.
- Step 5** (Optional) Click on the Filters button, and specify the desired filtering. For more information, see [Using Filters, page 3-12](#).
- Step 6** Click **Save and Close**.

**Tip**

Be sure that the user has access to the Alarms module. Click the **Modules** tab, select **Alarms** from the module list, and select the check box for **Allow access to module**. For more information, see [Defining User Profiles for Desktop Application Access, page 4-1](#).

## Configuring Time Schedules

Time schedules define when events and automated rules will run. See [Configuring Events and Alarms, page 12-37](#) and [Configuring Global I/O Automated Rules, page 13-18](#) for more information.

To create and modify time schedules, do the following:

- Step 1** Select **Time Schedules** from the **Admin** menu.

The Schedules main window displays the currently defined time schedules, as shown in [Figure 12-22](#).

*Figure 12-22 Schedules main window*

Name	Description	Type	Creation Date	Location
Always Deny	Always Deny Schedule Description	Access Policy	7/15/2015 14:18:24	
Always Permit	Always Permit Schedule Description	Access Policy	7/15/2015 14:18:24	
Default Schedule	All working days 8AM to 6PM sched...	Access Policy	7/15/2015 14:18:24	
Identiv Work Day Schedule	Access to perimeter doors Santa An...	Access Policy	8/21/2015 13:03:25	Identiv
Santa Ana Facility Access Policy	General Access M-F 8-5 pm	Access Policy	8/21/2015 13:05:28	Identiv
TRAINING LUNCH DOOR SCHEDULE	LUNCH UNLOCK OF CLASSROOM	Door Policy	8/21/2015 13:42:54	Identiv

Alarms: 5 active | 6 items | cpamadmin - SantaAnaCR

- Step 2** Click **Add**, or select an existing schedule and click **Edit** or **Delete**.

You can also right-click on an entry and then choose the **Add**, **Edit**, or **Delete** command from the pop-up menu.

**Step 3** (Add or Edit only) In the resulting dialog (such as the one shown in [Figure 12-23](#)):

*Figure 12-23 Add Schedule dialog*

Start	End	Days

- a. Type a unique **Name** for the schedule.
- b. Select a **Priority** from the drop-down list.
- c. (Optional.) Specify the **Location**.
- d. Define the schedule times:
  - Click **Add**, or select an existing entry and click **Edit** or **Delete**.
  - For **Add** or **Edit** only, specify the time interval for the schedule, as shown in [Figure 12-24](#).

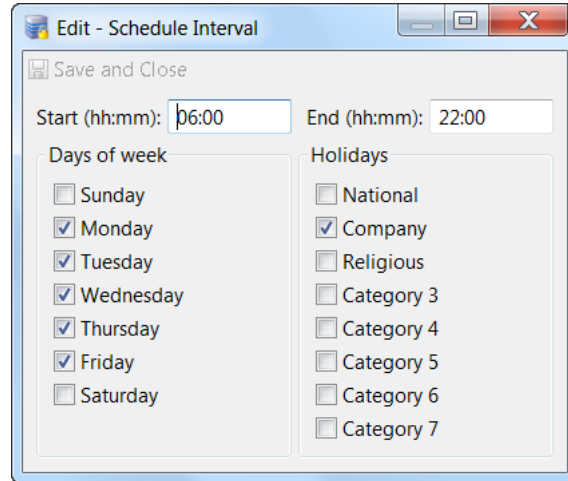

**Figure 12-24** Time Schedule Interval

- Specify the **Start** and **End** time in 24-hour and minute format (hh:mm)
- Select the **Days of week** for the schedule.
- Select additional **Holidays** for the schedule.
- When you are finished, click **Save and Close** to close this dialog and return to the previous window.

e. If necessary, define additional time intervals.

**Step 4** When you are finished, click **Save and Close** to save the changes in the detail window ([Figure 12-23](#)).

---

## Configuring Alert Sounds

Alert sounds play when an alarm occurs (if the alarm is configured with one of the available sounds). This section includes instructions to add or modify the available sounds. For instructions to assign the sounds to an alarm type, see [Modifying Default Event Policies](#), page 12-37.

To add or modify alert sounds, do the following:

- Step 1** Select **Alert Sounds** from the **Events & Alarms** menu, in the **Configuration** submenu. The **Alert Sounds** main window ([Figure 12-25](#)) shows the currently defined alert sounds.

*Figure 12-25 Alert Sounds main window*

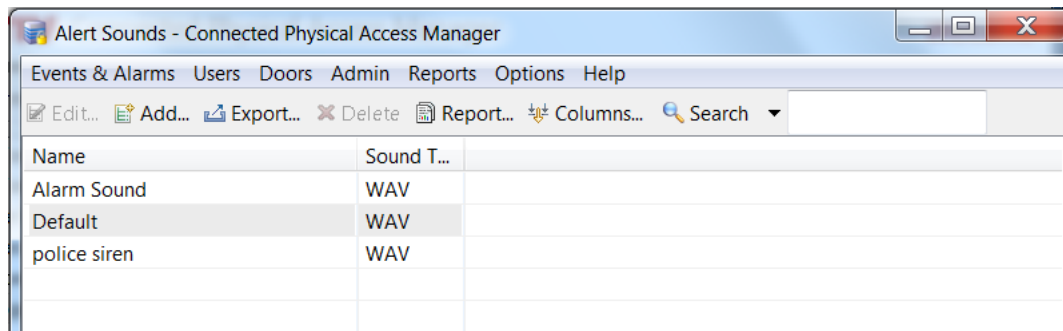

- To modify an existing alert sound, select the entry and choose **Edit...** to open the detail window. You can also double-click the entry.
- To add a new alert sound, click **Add...** to open the detail window.
- Click **Delete** to delete the selected entry.

- Step 2** Edit a new or existing alert sound using the detail window ([Figure 12-26](#)):

*Figure 12-26 Alert Sounds detail window*

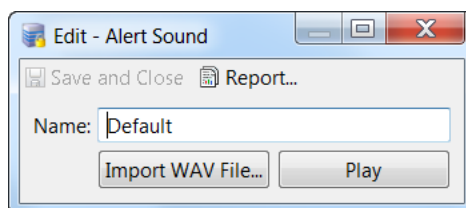

- Click **Import WAV File** and select a sound file from a local drive.
  - Click **Play** to preview the alert sound.
- Type a Name for the alert sound.
- Click **Save & Close**.

## Setting Event and Alarm Priorities

Priorities are used to sort or filter events and alarms. To define the priorities for an event or alarm log code, use the Event Policy Manager to edit the Priority setting for the Log Code:

- Step 1** Open the **Event Policy Manager** module in the **Events & Alarms: Configuration** menu.
- Step 2** Edit an event policy by selecting it and clicking the **Edit...** button in the toolbar.
- This opens an **Event Policy** detail window (as shown in [Figure 12-27](#)).

**Figure 12-27** Event Policy detail window

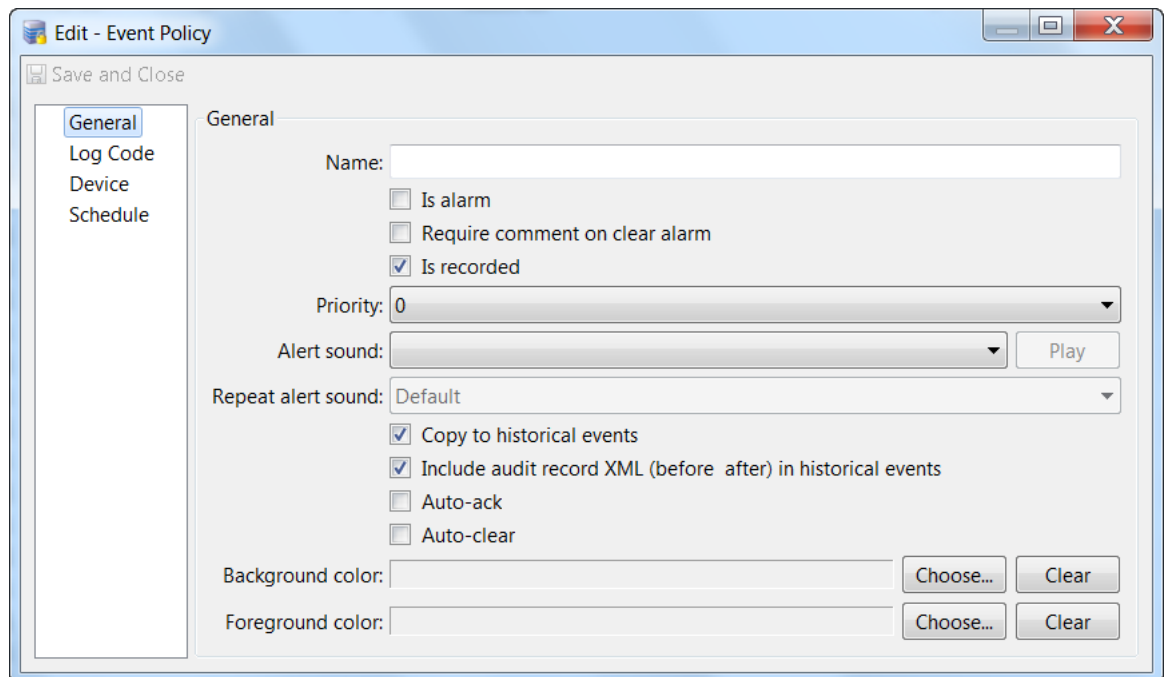

- Step 3** Use the **Priority** drop-down list to change the priority of the event or alarm. Positive priorities are above normal priority, and negative priorities are below normal. Zero is normal.
- Step 4** Click **Save and Close** to save your changes.
- For more information, see [Modifying Default Event Policies, page 12-37](#).

## Defining User Privileges for Editing Events

To change the event fields to read-only, change the access privileges of the user profile:

- Step 1** Select **Profiles** in the **Users** menu.
- Step 2** Click **Add**, or select an existing profile and click **Edit**.
- Step 3** In the resulting window, click the **Data Types** tab. (See [Figure 12-28](#).)

*Figure 12-28* Selecting Editable Fields in the Profiles module

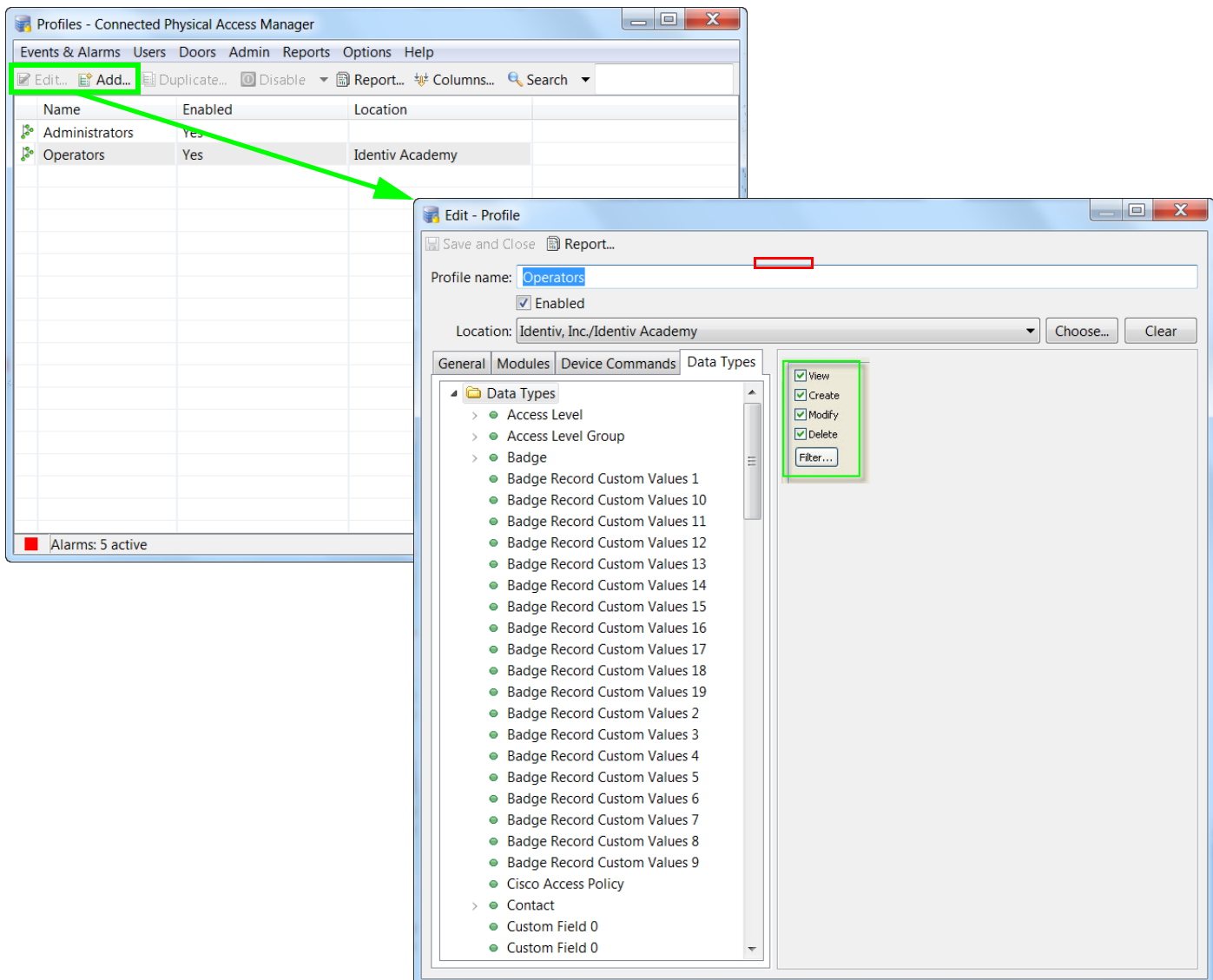

- Step 4** Click on the Data Type that you want to edit. For example, **Badge**, **Personnel Record**, etc.
- Step 5** Select or deselect the options for the user profile to **View**, **Create**, **Modify**, or **Delete**.
- Step 6** Click **OK** to save the changes.

# Using Graphic Maps

Graphic maps provide a visual representation of the devices available in a location. Icons representing the devices provide real-time status and alarms information, and allow the user to trigger actions such as viewing live video or denying access to a door. Automated rules can also be invoked, and icons representing a location provide status and alarm summary for all the devices assigned to that location.

## Graphic Maps in ICPAM 2.1

If the profile enhancement feature is set in the system configuration settings ([Logins page of the System Configuration window, page 17-11](#)), the following changes are impacted in this module:

- The Graphic maps are displayed to users based on the hierarchical location assigned to their user profiles. For example: if a user profile “campusadmin” is assigned to a location “BVVC”, the user can view maps related to this location and its sub-locations only. If the user tries to view any other location maps, an error is displayed. See [Figure 12-29](#).

**Figure 12-29** Location-specific Graphic

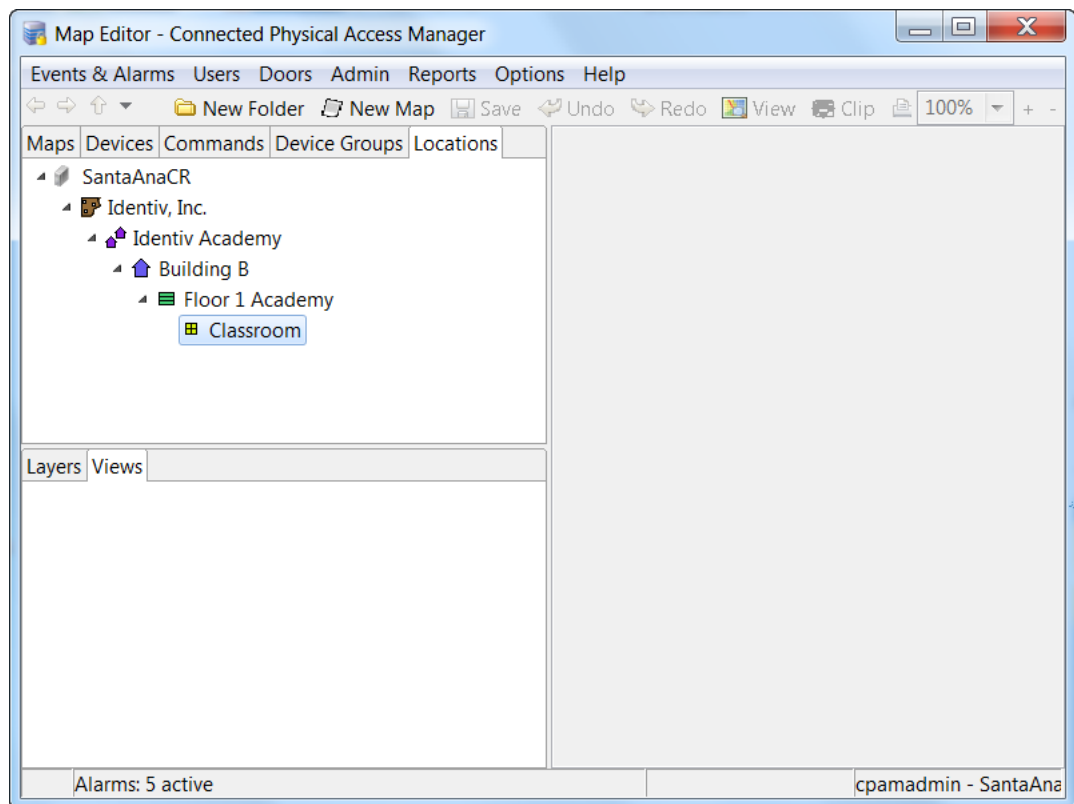

- When location-restricted users create a new map, they can select from a list of devices that are populated based on the location to which they are assigned.
- All device groups up to the root of the location-restricted user are visible, and the user can reuse these device groups if at least one device is present in the location-restricted user’s assigned location.
- The maps created by cpamadmin are not restricted by any hierarchical location.

- The location-restricted user is restricted from viewing maps created by the cpadmin.
- The hierarchical location is auto-populated for a location-restricted user while creating maps.
- When the cpadmin removes a location from the location-restricted user's hierarchy, all devices of that location is removed automatically. However if any device commands relating to these devices are present, then it requires manual removal, so the cpadmin should ensure that they remove all associated devices/commands (manually) along with the location.

**Note**

These points are applicable only when the profile enhancement feature is set on the **Logins** page of the **System Configuration** window (starting with the ICPAM 2.1 release); otherwise, the ICPAM appliance retains its behavior as in the previous version (CPAM 1.5.1).

The following sections describes the map viewer, and the editor used to create the maps:

- [Maps Viewer, page 12-50](#)
- [Map Editor, page 12-55](#)

## Maps Viewer

Select **Maps** from the **Monitoring** submenu under the Events & Alarms menu.

*Figure 12-30 Command on the Events & Alarms menu for opening the Maps Viewer*

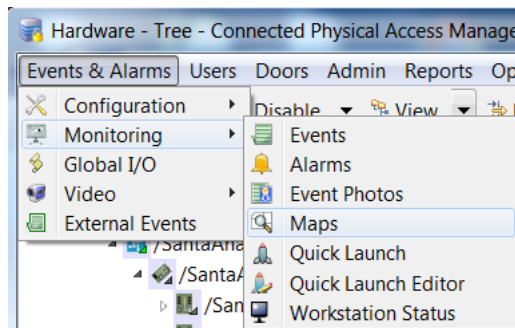

[Figure 12-31](#) shows a sample map. In the top left frame, click + and - to expand and collapse the map folders and view associated devices. Right-click on a device to view the pop-up menu of actions and commands available for that device.

Figure 12-31 Maps Viewer main window

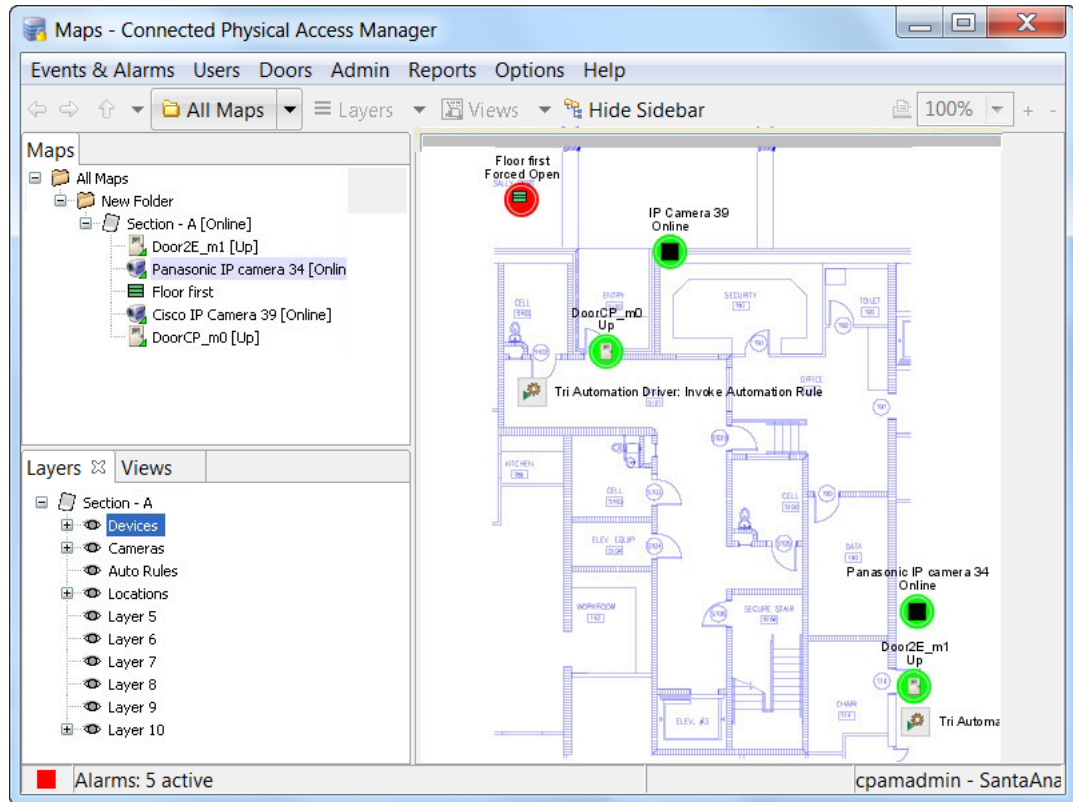

## Icon Colors and Status

On the map, icons representing devices, automated rules, and locations provide status information using two colors: the inside fill color and the outside ring color.

### Inside Fill Color

The inside color represents the device state.

- *Light Green*: Represents armed, secure, online states.
- *Red*: Represents unknown, active, offline states.
- *Dark Blue*: Represents disarmed, inactive states.
- *Light Blue*: Represents disarmed, active.

### Outer Ring Color

The outer ring color represents the alarm state.

- *Green*: Represents a normally operating device free of any alarms.
- *Orange*: Represents a device in an acknowledged alarm or alarms state.
- *Red*: Represents a device in an alarm state.

Figure 12-32 Icon Colors and Status

Inside Color	Outside Color	Device Status Description
	 Red	Alarm(s)
	 Orange	Acknowledged alarm(s)
	 Green	No alarms
 Red		Unknown, fault or active state
 Green		Armed and inactive state
 Light Blue		Disarmed and active state
 Dark Blue		Disarmed and inactive state

272107



## Device Commands

Right-click on a device's icon to view the pop-up menu of available commands for that device. For example, you can view live video for a camera, or deny access for a door, depending on your access privileges.



**Tip**

To trigger an automated rule, click the icon.

*Figure 12-33 Viewing the Available Commands for a Device*

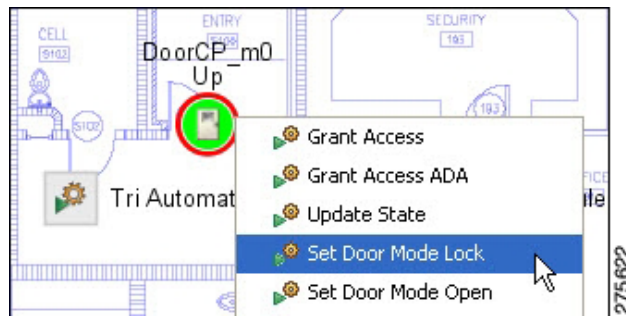

## Layers and Views

### Layers

Layers enable you to hide or display categories of icons, depending on the map configuration.

Click the Layers tab in the bottom left of the window, then right click the layer title and select **Toggle Layer Visibility**.

For example, turn the Doors layer off to hide the door icons. Toggle the layer on to display the icons.

Layers that contain one or more devices have a + sign to the left of the layer icon, allowing it to be expanded to show the associated devices.

*Figure 12-34 Layers*

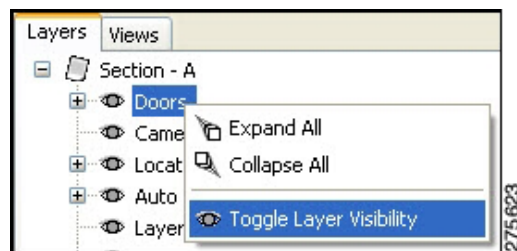

### Views

Click the Views tab to select the available views. For example, one view may display an entire floor plan, while another view displays only the reception area.

Figure 12-35 Views

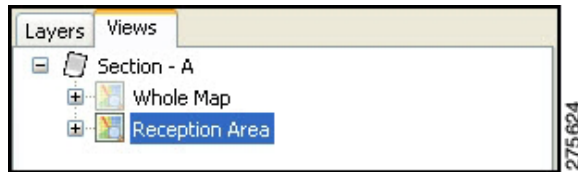

## Toolbar and Navigation Controls

Use the toolbar controls to select maps and adjust the map display.

Figure 12-36 Toolbar and Navigation Controls



Table 12-9 Toolbar and Navigation Controls

Control	Description
<b>Back Arrow</b>	Navigates backwards in the viewed maps history.
<b>Forward Arrow</b>	Navigates forward in the viewed maps history.
<b>Up Arrow</b>	Navigates to maps linked to the displayed map.
<b>All Maps</b>	Opens a menu containing all maps for easy navigation regardless of whether the sidebar is shown.
<b>Layers</b>	Displays all layers in the open map, and allows you to show and hide layers, regardless of whether the sidebar is shown.
<b>Views</b>	Displays a selected view, regardless of whether the sidebar is shown.
<b>Hide/Show Sidebar</b>	Hides or shows the sidebar in the Layers and Views tabs in the sidebar.
<b>Print</b>	Prints the currently displayed map.
<i>Zoom</i>	The zoom tool is located in the upper right of the <b>Graphic Maps Viewer</b> . Use the drop-down arrow to select a zoom percentage, or type in custom zoom percentage number and press Enter. To cancel the zoom and reset the view, use the zoom tool drop-down and select <b>Reset</b> , or click <b>Reset View</b> .
<i>Zoom Marquee</i>	To zoom into a specific map area; hold down the Control button, click and drag the dotted rectangle on the map. Release the mouse button and the view zooms to fit the rectangle. To scroll the screen, hold down the Shift button, click the left mouse button while dragging to a desired location.

# Map Editor

Use the **Map Editor** to create facility maps and add icons that represent doors, cameras, locations, and automated rules. After being created, the maps are viewed using the **Maps Viewer**.



## Caution

Do not use the **Map Editor** while another client workstation has the **Maps Viewer** or **Map Editor** open. Using the **Map Editor** while any other client workstation has the **Maps Viewer** or **Map Editor** open may result in system errors.

To create or modify graphic maps, do the following:

- Step 1** Select **Map Editor** from the **Admin** menu.

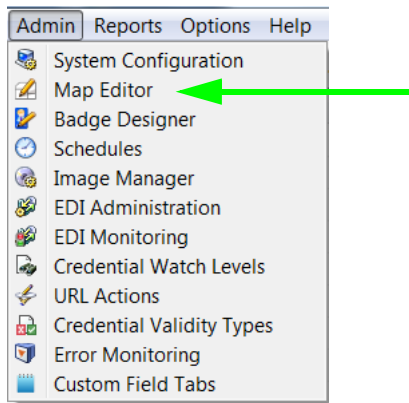

- Step 2** (Optional) Add a folder for map organization:

- a. Click **New Folder**.



- b. To rename the folder, right click on it and select **Folder Properties** from the pop-up menu.

- Step 3** Create a new map:

- a. Click **New Map**.

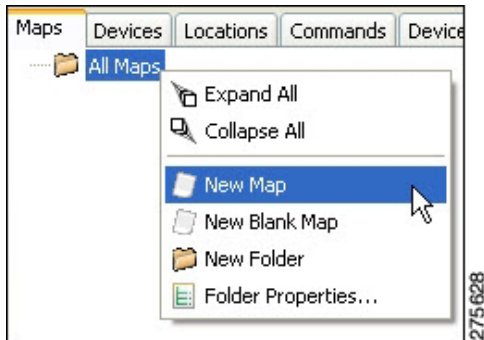

- b. Select a background image from a local drive. Background images are typically floorplans.

**Step 4** (Optional) Use the clip and zoom controls to adjust the image:

- **Clip:** use the **Clip** button to crop an image. To clip an image, click the **Clip** button, click and drag a rectangle on the image, and then click **Clip** again to crop the image.
- **Zoom:** zoom in or out using the zoom tool in the upper right of the window. Click + or - to zoom in and out, select a zoom percentage, or enter the percentage in the box.

To cancel the zoom and reset the view, select **Reset** from the drop-down menu, or right-click the image and click **Reset View**.

- **Zoom Marquee:** to zoom an image using the zoom marquee feature, hold down the Control button, click and drag a rectangle on the image. Release the mouse button and the image will zoom to fit the rectangle.

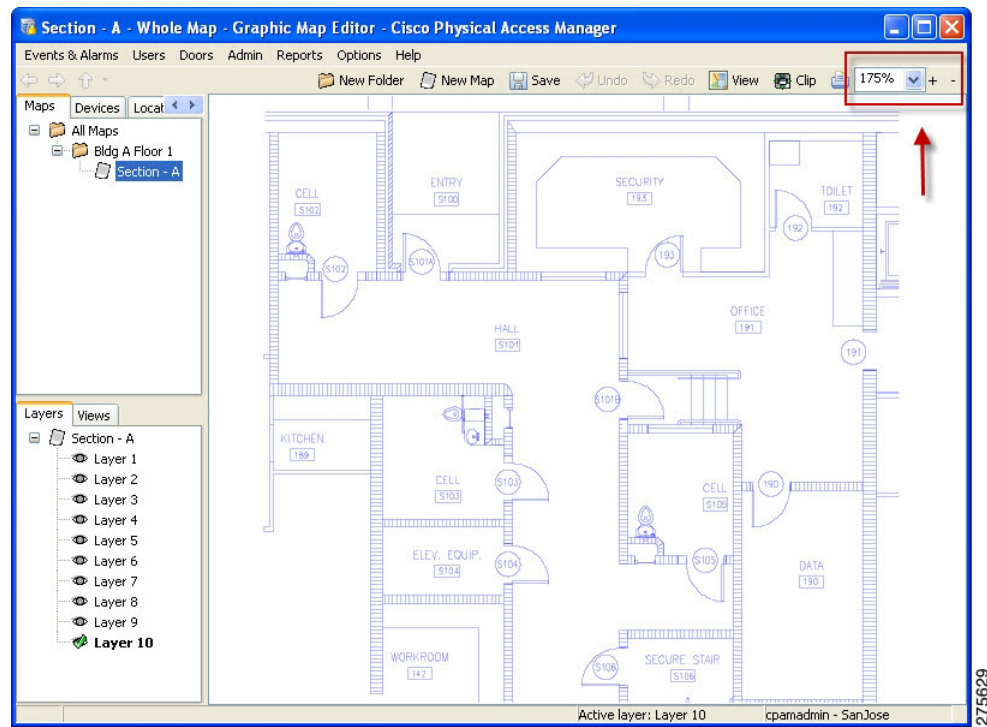

**Tip**

To move an image, hold down the Shift key, click on the image, and drag it to the desired location. Navigate between modifications by clicking the **Undo** and **Redo** buttons.

**Step 5** (Optional) Right-click the image to access the following functions:

- **Reset View:** cancel a zoom view and return to 100%.
- **Change Background:** selects a new background image for the image.
- **Edit Properties:** defines the properties of the image, such as the icon scale.
- **Edit View Properties:** defines layout properties.
- **Toggle Layer Visibility:** turns layer visibility on or off.
- **Edit Layer Properties:** edits the layer name.

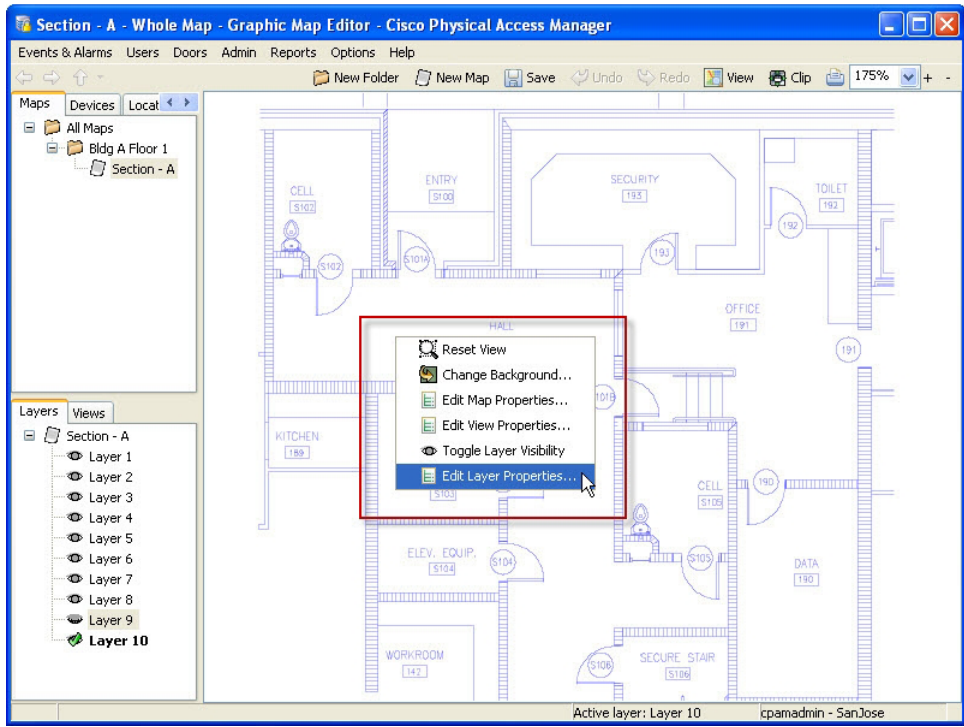

- Step 6** Add devices or doors to the appropriate location on the image.  
The device will report its real-time status in the Maps Viewer.
- Click the **Devices** tab to view the controllers, doors, and drivers.
  - Drag a device from the tree and drop it onto an appropriate place on the image.

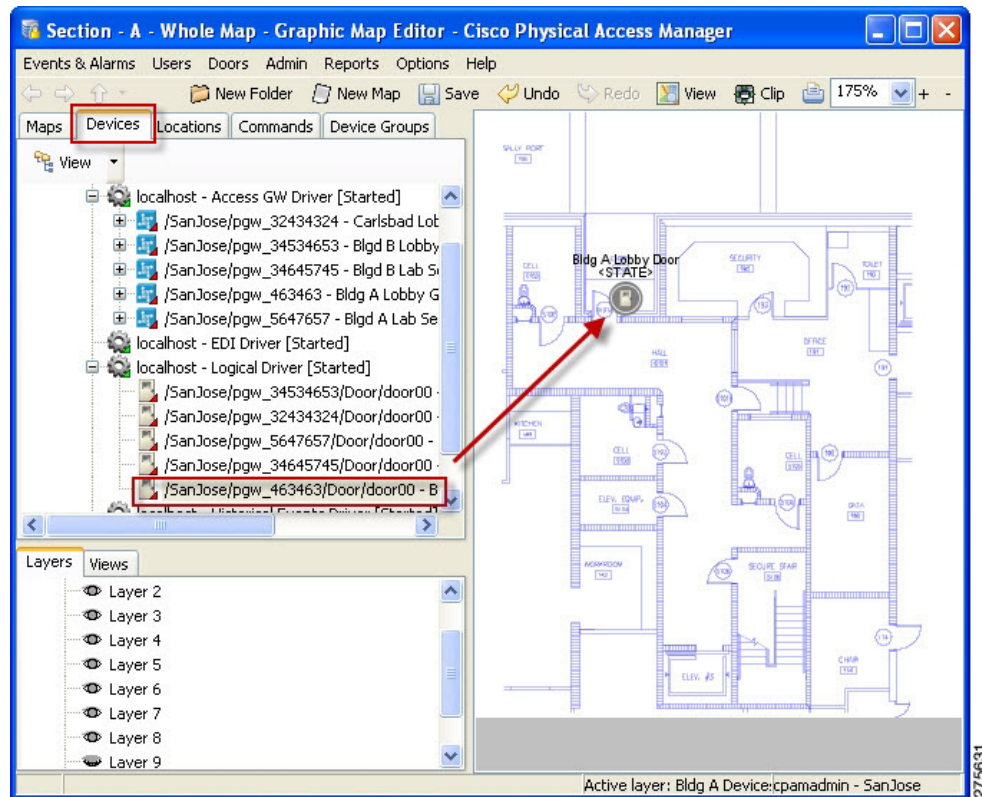

**Tip**

To add a Door Group, click the **Device Groups** tab and drag the door group to the image. See [Configuring Device Groups, page 7-24](#) for more information.

- Step 7** Add locations to the map.
- Click the **Locations** tab.
  - Drag a location from the tree and drop it onto an appropriate place on the map.

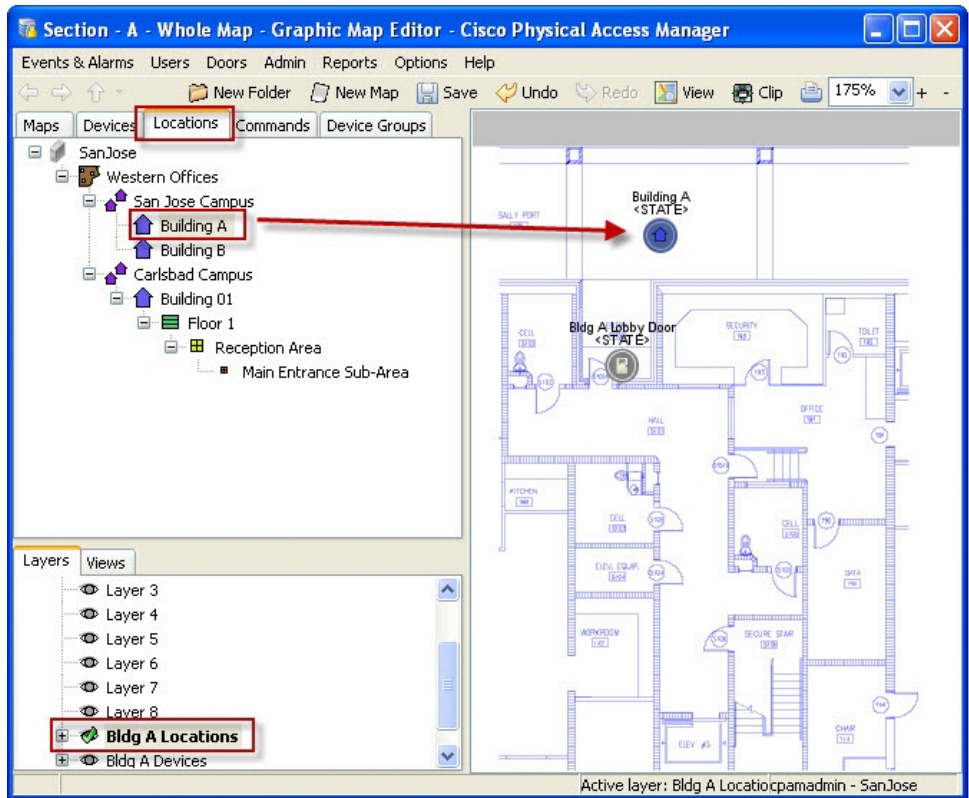
**Tip**

Click a Layer icon in the bottom left window to organize the image elements into different layers. For example, click a layer and add the devices, then click another layer and add locations or commands. You can turn layers on or off by right-clicking the layer and selecting **Toggle Layer Visibility**. Select Edit Layer Properties to rename the layer. A green check indicates the active layer that new icons will be added to.

- Step 8** Add commands to the map. Users can click on command icons in the [Maps Viewer](#) to invoke the command.
- Click the **Commands** tab to view the commands available for the selected device.
  - Drag a command to the map. The Device Command window opens.
  - Click **OK** to accept the selected command and add it to the map.

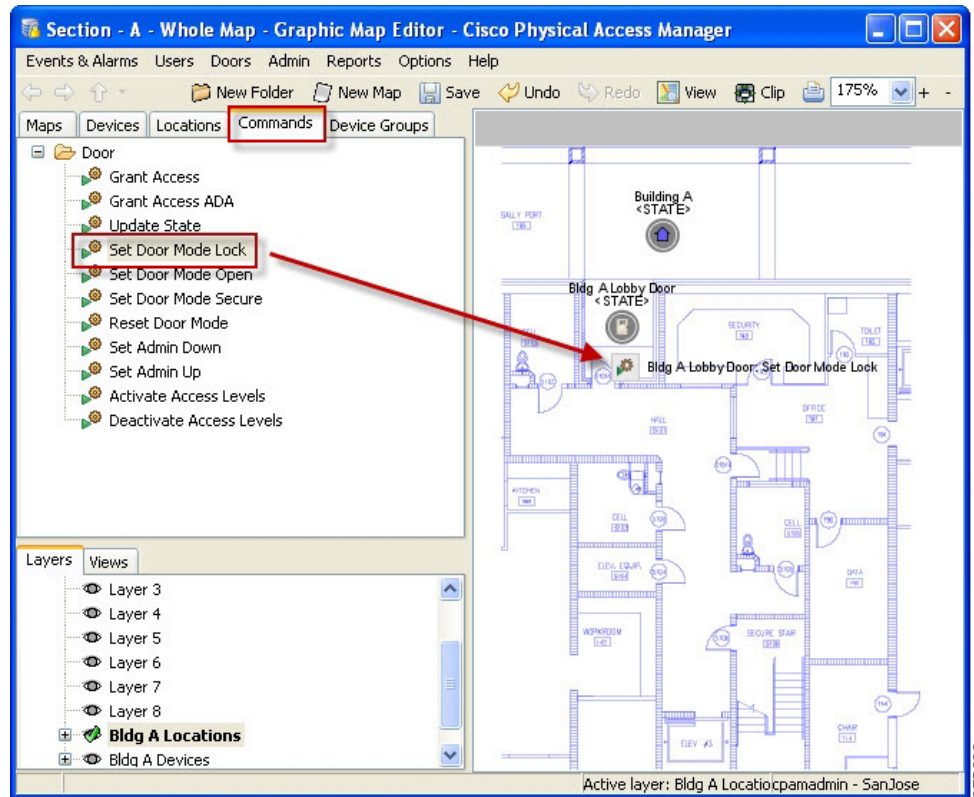

- Step 9** (Optional) To select a different device and command combination using the Device Command window, do the following:
- Select the device(s)
    - **Single**: click **Choose** and select a single device or door from the Hardware - Tree view, as shown in the example to the right.
    - **Multiple (by filter) of type**: select a device type from the drop-down menu. To refine the selection, click **Filter** and select the filter options.
    - **Multiple (by group) of type**: select a device group from the drop-down menu.
  - Select a command for the device(s): click **Choose** and select a command from the list.



- c. (Optional) Click **Choose** to select the Parameters for the command, if required.

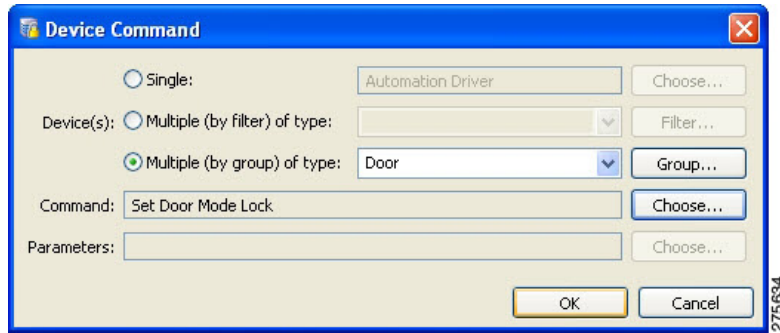

**Note** If **Choose** is shown in black, you must click the button to continue. Select a parameter from the list. If the message “*Are you sure you want to continue?*” appears, click **OK**. This message indicates that a parameter is not required.

- d. Click **OK**.

**Step 10** (Optional) Add automated rules to the image.

- a. Click the **Devices** tab and select the **Automation Driver**.
- b. Click the **Command** tab and drag the icon for **Invoke Automation Rule** to the image. The Device Command window appears.

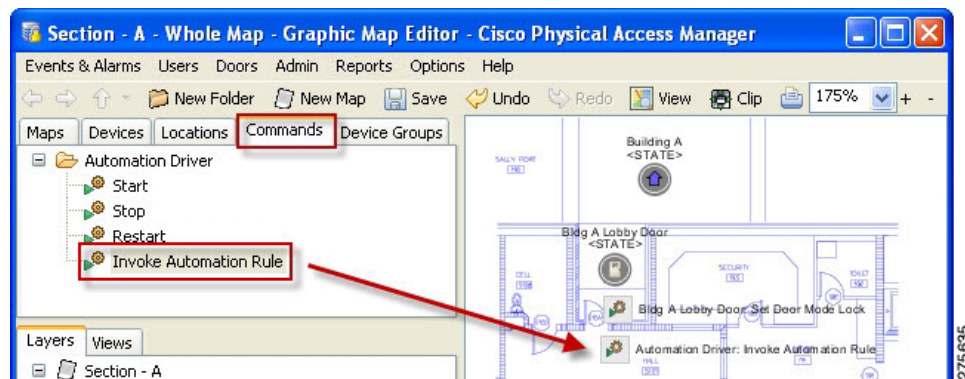

**Note** In the Device Command window, the selected device is **Automation Driver**, and the selected command is **Invoke Automation Rule**.

- c. To select the rule, click **Choose** in the Parameters field and select the rule.

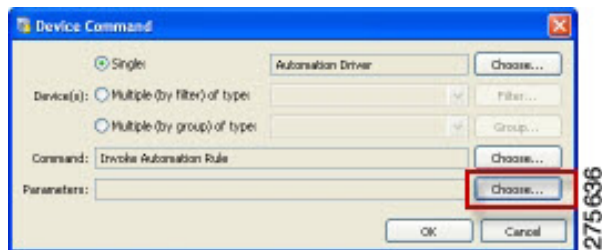

- d. To define rules, see [Configuring Automated Tasks Using Global I/O](#), page 13-20.

- Step 11** (Optional) Create multiple views of the map.
- Zoom and position the map to focus on a specific area or set of devices.
  - Click **View** in the top menu bar.
  - Use your mouse to click and drag a border within the map.
  - Release the mouse button to select the area.  
The Map View window appears.
  - Adjust the View properties as needed. For example, click **Make default view** to make the view the default when the map is opened in the **Maps Viewer**.
  - Click **OK** to save the changes and create the new view.

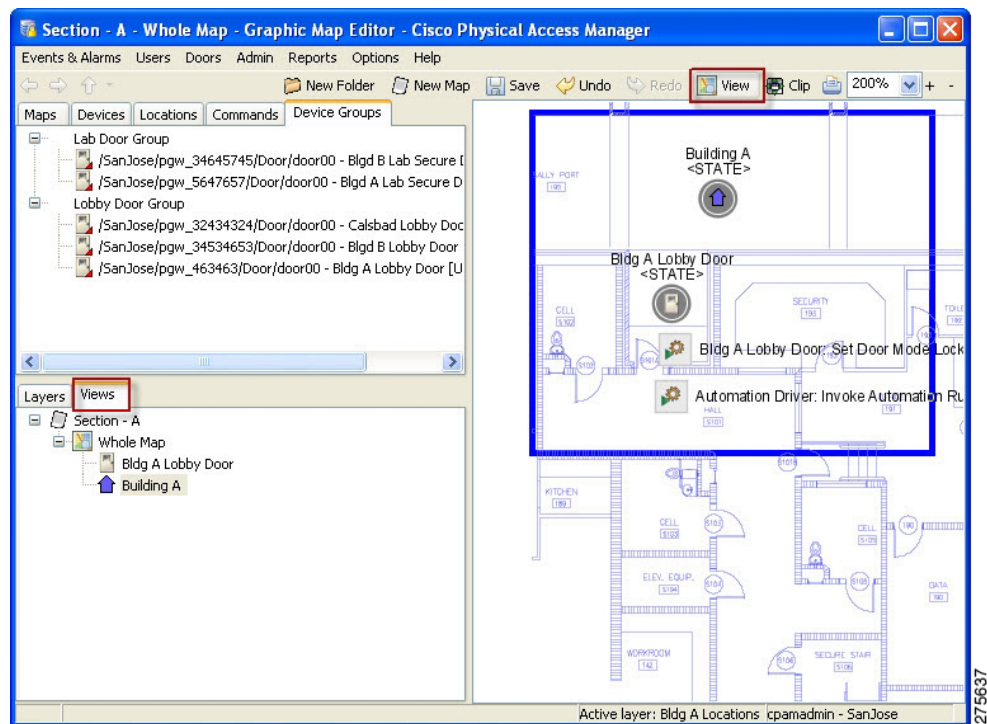

- To change the name and other settings, right-click the view name and select **Edit View Properties**.

**Step 12** (Optional) Edit the icon properties.

Right-click an icon and select **Edit Icon Properties**.

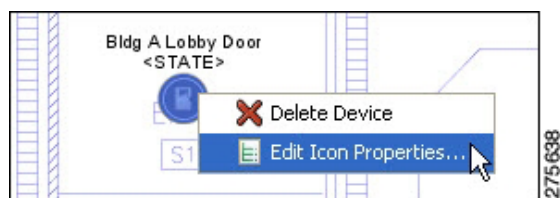

To change the icon's image, click **Choose** in the Image section of the Properties window.

**Step 13** Click **Save**. (Changes are visible in the graphic Maps Viewer only after they have been saved.)

# Backing Up and Archiving Events

You can include or exclude events from system backups. You can also *prune* and *archive* old events to remove them from the main database. The following topics provide more information:

- [“Including Events In System Backups” section on page 12-63](#)
- [“Pruning and Archiving Old Events” section on page 12-63](#)
- [Creating Reports from Pruned Events, page 12-64](#)

## Including Events In System Backups

Events can either be included or excluded from system backups, as described in the [“Backing up the ICPAM Database” section on page A-2](#). Including events allows you to restore those events along with other data and configurations. However, the backup process will take longer and the backup file will be larger.

Excluding events from a system backup reduces the size of the backup file, and the time required to complete the backup process.

## Pruning and Archiving Old Events

As an alternative to backing up all events, you can *prune* and *archive* old events.

- *Pruned* events are removed from the live database table and placed in a separate database table, allowing you to reduce the size of the main database while keeping them accessible on the ICPAM system. Pruned events are not visible in Events & Alarms, but are included in reports. Pruned events are also included in system backups.
- *Archived* events are removed from all ICPAM database tables and copied to a compressed file. The file includes a password-protected SQL script, and can be run on an offline database to view the purged events. Archived events are not visible in the Events & Alarms listings or Reports, and are not included in system backups.

Archiving historic events improves system performance and simplifies monitoring since only the latest, most relevant, events and alarms are displayed. System backup file sizes are also reduced. In addition, the historical event records are self-contained. Referenced objects, such as a person's name and card number, are retained even if the original record is deleted. Reports on historical events can also span a much longer time range than is normally possible for live events.

Archived event files can be restored to the ICPAM database, if necessary, or used by other applications to view old events or run reports. See the [“Creating Reports from Pruned Events” section on page 12-64](#).

See the [“Archiving Historical Events” section on page 2-25](#) for more information.

## Creating Reports from Pruned Events

To run reports on historical events that were copied to the historical events database, create a filter-based report in the Report Manager.

**Step 1** Select **Reports** from the Reports menu.

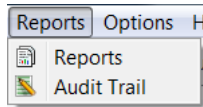

**Step 2** Click **Add** and select **Add Filter-based Report**.

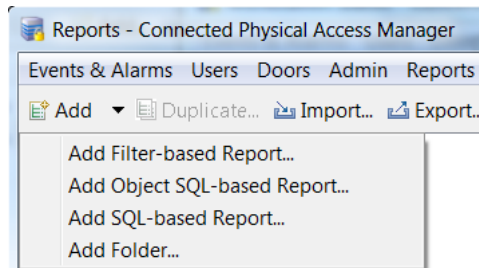

**Step 3** Specify the report settings:

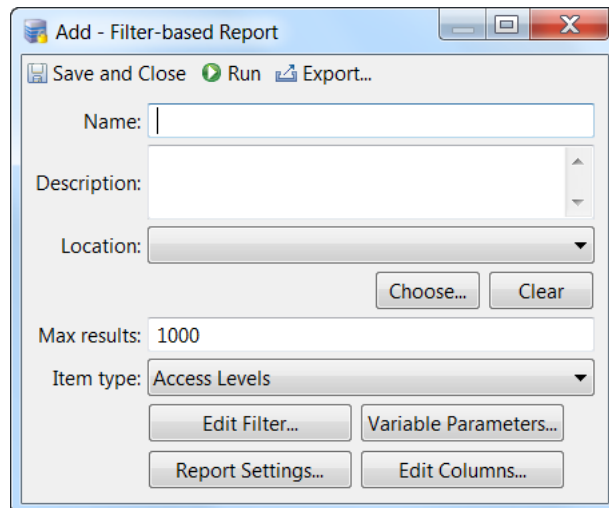

- **Name:** the name of the report.
- (Optional.) **Description:** type some text describing the report.
- (Optional.) **Location:** specify the location for the report.
- **Max results:** the number of results displayed in the report. -1 is unlimited results.
- **Item type:** select **Events (Historical)**.
- **Edit Filter:** the filter setting, similar to filters available in the toolbar. See [Using Filters, page 3-12](#).
- **Variable Parameters:** information the user will be prompted to provide when the report is run.
- **Report Settings:** Report generation options, which are the same as when generating a report from one of the other modules. For more information see [Creating Reports, page 3-10](#).

- **Edit Columns:** specify the columns used in the report. Use the Up and Down buttons to reorder the columns for the report.

**Step 4** Click **Save and Close**.

---



## Configuring Automated Tasks

---

This chapter describes how to create and manage automated tasks such as triggering a relay when an alarm is generated, playing an alarm video, or sending an event e-mail.

In addition, you can create Quick Launch buttons for commonly used actions, and organize the buttons into different panels.

### Contents

- [Creating Quick Launch Buttons, page 13-2](#)
  - [Creating a Button, page 13-2](#)
  - [Creating a Button That Runs An Automated Rule, page 13-8](#)
  - [Creating Panels \(Windows\) of Related Buttons, page 13-9](#)
  - [Restricting User Access to Button Panels, page 13-10](#)
- [Configuring Edge Policies, page 13-11](#)
- [Configuring Device I/O Rules, page 13-16](#)
- [Configuring Global I/O Automated Rules, page 13-18](#)
  - [Enabling the Automation Driver, page 13-18](#)
  - [Configuring Automated Tasks Using Global I/O, page 13-20](#)
  - [Global I/O Example: Automated Weekly Report, page 13-29](#)
- [Automation Rules in ICPAM 2.1, page 13-33](#)
- [Defining Reports \(Report Manager\), page 13-36](#)
  - [Using the Report Manager, page 13-37](#)
  - [Filter-based Report Template, page 13-38](#)
  - [SQL-Based Report Template, page 13-41](#)

## Creating Quick Launch Buttons

Quick Launch buttons provide one-click access to commonly used actions. For example, you can create buttons to unlock a door or open an ICPAM module. Complete the following instructions to create or modify buttons, and organize them into different panels (windows).

- [Creating a Button, page 13-2](#)
- [Creating a Button That Runs An Automated Rule, page 13-8](#)
- [Creating Panels \(Windows\) of Related Buttons, page 13-9](#)
- [Restricting User Access to Button Panels, page 13-10](#)

### Creating a Button

To create a button, perform the following procedure.

- Step 1** Select **Quick Launch Editor** from the **Events & Alarms** menu in the **Monitoring** submenu. The Quick Launch Editor window opens.

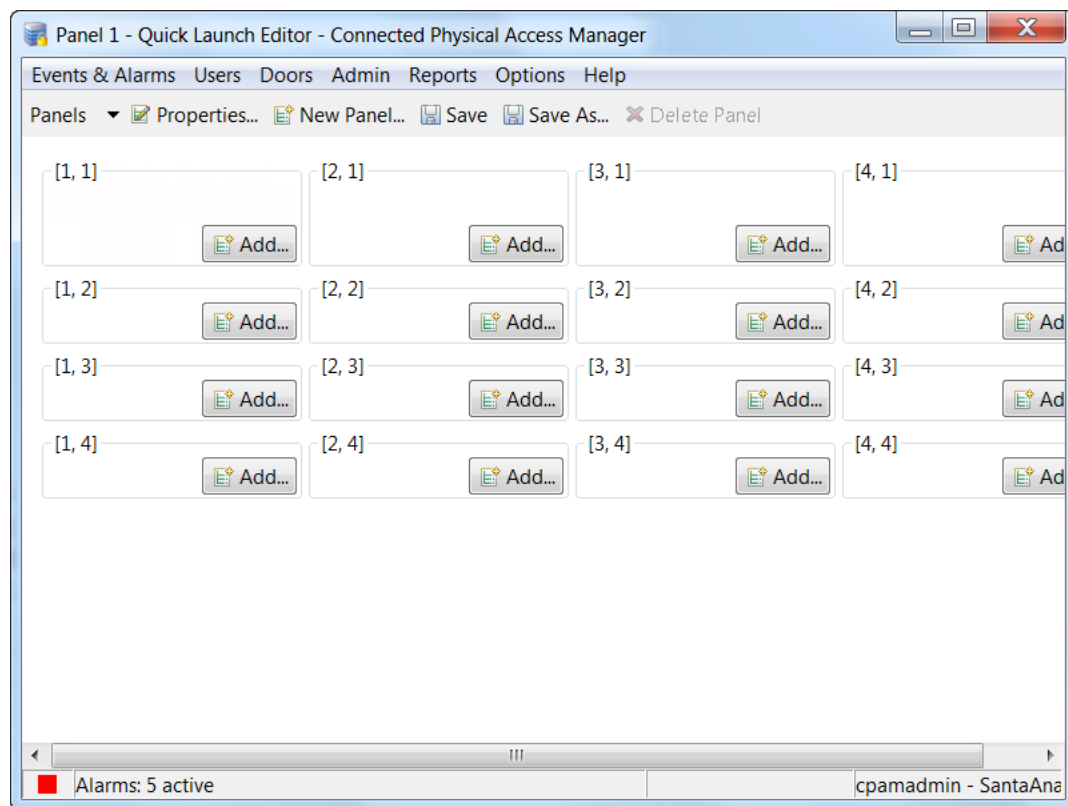

- Step 2** Click on the **Add** button for the row and column where the new button will appear in the Quick Launch window.



**Step 3** In the resulting **Select Widget Type** dialog, select the widget's **Type** from the drop-down list, and click **OK**.

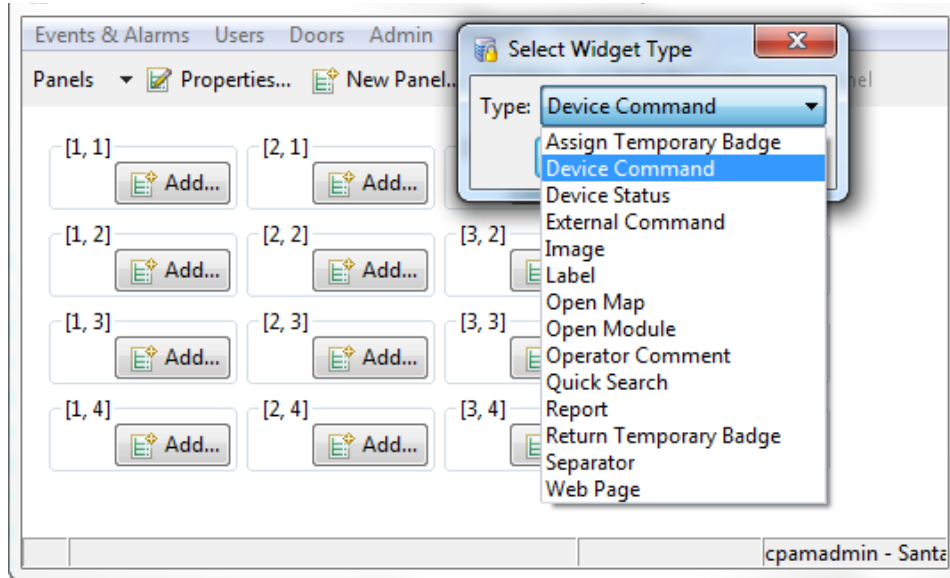

The widget types include:

- **Device Command:** creates a button that executes a command for a door or device. For example, grant access to a door.
- **Open Module:** creates a button that opens a ICPAM module window.
- **Label:** Creates a text label used to organize Quick Launch buttons into rows and columns.

**Step 4** The content of the resulting window and the required steps vary depending on the selected widget type.

#### For a Device Command widget

On the resulting **Add Device Command Widget** window:

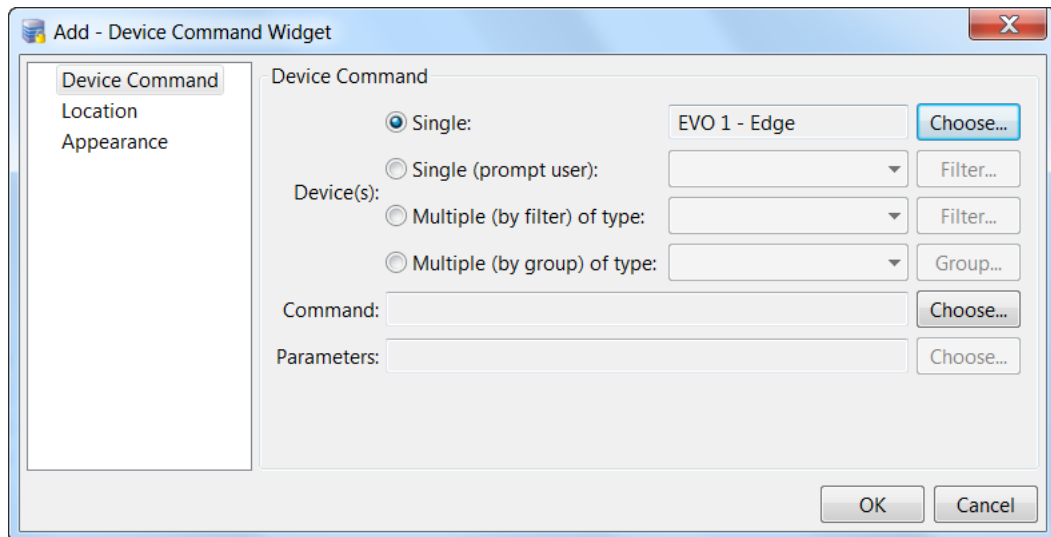

1. On the **Device Command** page, specify the required settings for the desired device command.
  - a. Select the device(s):
    - **Single**: click **Choose**, then in the resulting dialog select a single device or door from the Hardware - Tree view, and click **OK**.

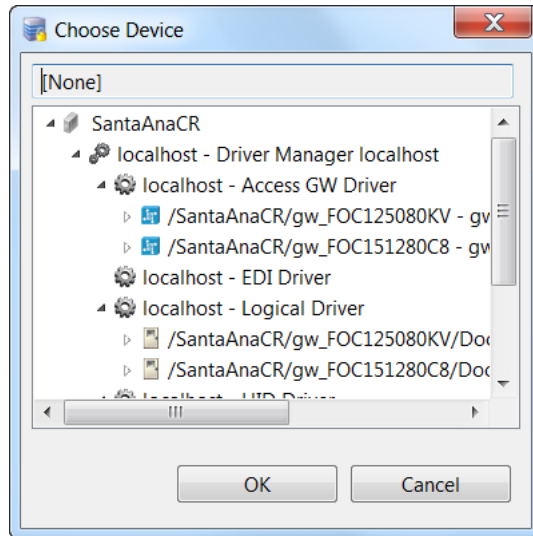

- **Multiple (by filter) of type**: select a device type from the drop-down menu. For example, select *deadbolt* to select all deadbolt devices in all doors. To refine the selection, click **Filter** and select the filter options.
  - **Multiple (by group) of type**: select a device group from the drop-down menu. Groups include:
    - **Access Point**
    - **Door**: select a Door Group. See [Configuring Device Groups, page 7-24](#).
    - **Monitor Point**
    - **Monitor Point Group**
- b. Select a command for the door or device(s):
    - Click the **Choose** button to the right of the **Command** field.
    - In the resulting **Choose Device Command Type** dialog, select a command (such as **Deactivate Access Policies**) from the list, and click **OK**.



**Tip** See [Device Commands, page 7-46](#) and [Door Modes and Commands, page 7-47](#) for command descriptions.

- c. If required, specify the parameters for the selected command:
  - If the **Choose** button to the right of the **Parameters** field is enabled, you must click that button to continue. In the resulting dialog, select a parameter from the list, and click **OK**.
  - If a message dialog asking “*Are you sure you want to continue?*” appears, click **OK**. This message indicates that a parameter is not required.

- On the **Location** page, specify the desired position for this new button:

- Specify the **Column** and **Row** numbers that indicate the button's position.



**Note** If a button already exists in that location, the existing button automatically shifts to the right.

- For a larger button, increase the value in the **Horizontal span** or **Vertical span** fields.
- On the **Appearance** page, specify the text label and icon image that will appear on the button for this device command:

- Specify the text **Label** for the button:
  - Default:** the default text generated by the program. For example, the name of the device and command.
  - None:** no text label. Only the icon image appears. (If no icon image is selected, a blank button is displayed.)
  - Custom:** type the custom text for this button.

- Specify the icon **Image** for the button:
    - **Default:** the default icon image supplied by the program.
    - **None:** no button image. Only the text label appears. (If no label is specified, a blank button is displayed.)
    - **Custom:** click Choose to select a custom image file.
4. When you are finished, click **OK**.

The new button appears on the main Quick Launch page.

#### For an Open Module widget

On the resulting **Add Open Module Widget** window:

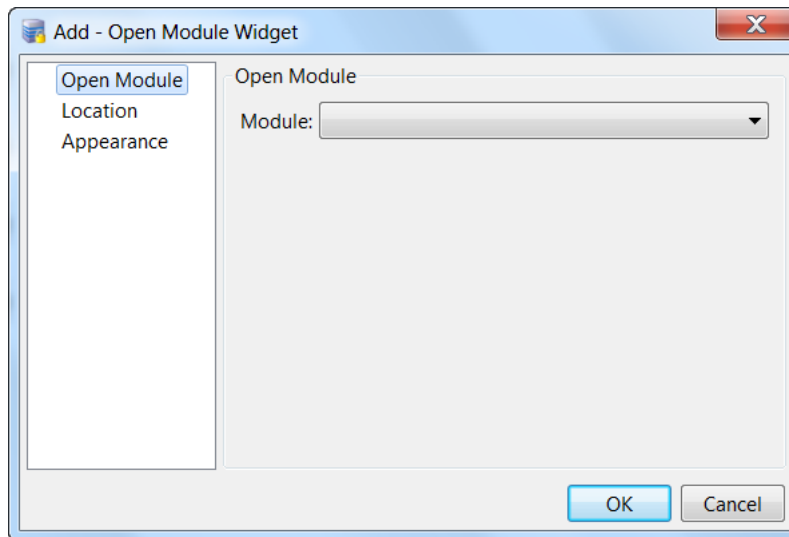

1. On the **Open Module** page, select the desired ICPAM module from the drop-down list.
2. On the **Location** page, specify the desired position for this new button:
  - Specify the **Column** and **Row** numbers that indicate the button's position.



**Note** If a button already exists in that location, the existing button automatically shifts to the right.

- For a larger button, increase the value in the **Horizontal span** or **Vertical span** fields.
3. On the **Appearance** page, specify the text label and icon image that will appear on the button.
    - Specify the text **Label** for the button:
      - **Default:** the default text generated by the program. For example, the name of the module.
      - **None:** no text label. Only the icon image appears. (If no icon image is selected, a blank button is displayed.)
      - **Custom:** type the custom text for this button.
    - Specify the icon **Image** for the button:
      - **Default:** the default icon image supplied by the program.
      - **None:** no button image. Only the text label appears. (If no label is specified, a blank button is displayed.)

- **Custom:** click Choose to select a custom image file.

4. When you are finished, click **OK**.

The new button appears on the main Quick Launch page.

#### For a Label widget

Type the text for this label, then click **OK**.

The new button appears on the main Quick Launch page.

**Step 5** (Optional) To create additional quick launch buttons, repeat Steps 2 through 4.

**Step 6** (Optional) To organize the buttons in the current panel (window):

- To edit an existing button (widget): right-click the button, select **Edit** from the pop-up menu, and edit the properties as necessary.
- To move the buttons on the page, do one of the following:
  - Right-click the button and select either **Move Left**, **Move Right**, **Move Up**, or **Move Down** from the pop-up menu.

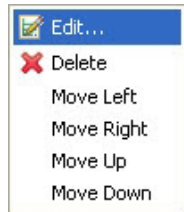

- Right-click the button, then select **Edit > Location** to specify the row and column for the desired position.

**Step 7** (Optional) Create panels (windows) of related buttons.

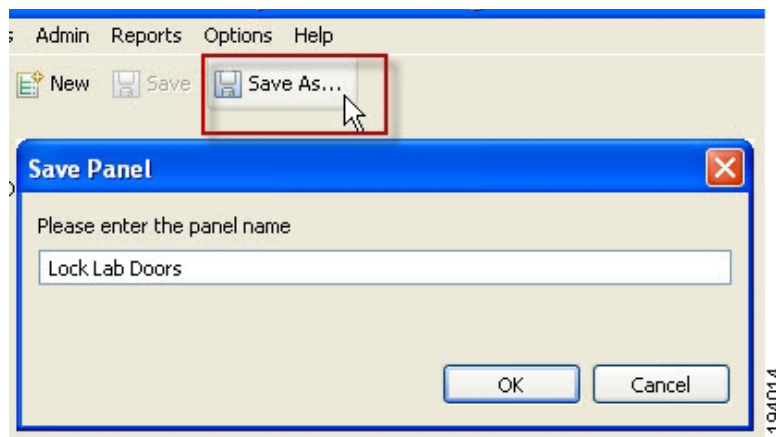

## Creating a Button That Runs An Automated Rule

Create a button that runs an automated rule.

- Step 1** Select **Quick Launch Editor** from the **Events & Alarms** menu in the **Monitoring** submenu.
- Step 2** In the resulting Quick Launch Editor window, click on the **Add** button for the row and column where the new button will appear in the Quick Launch window.
- Step 3** In the resulting **Select Widget Type** dialog, select **Device Command** from the **Type** drop-down list, and click **OK**.

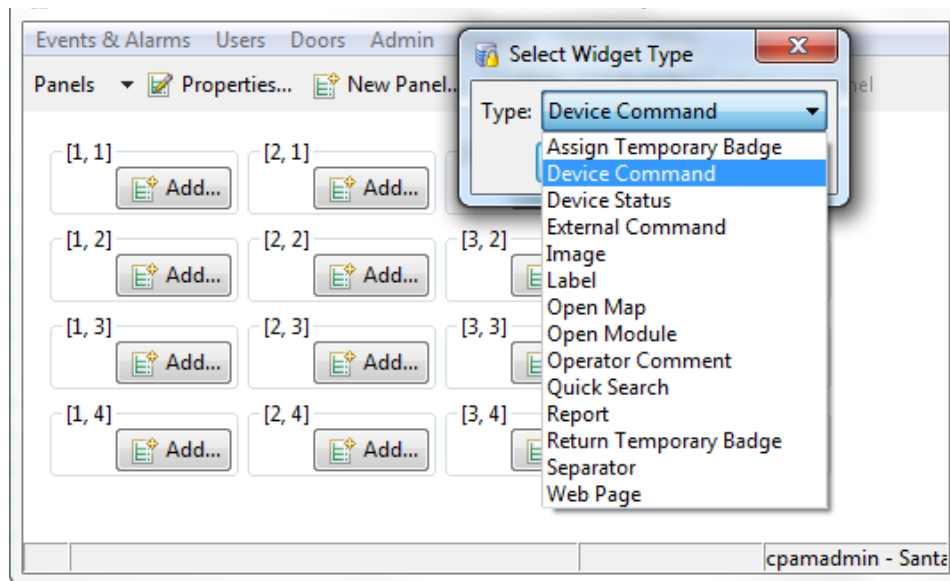

- Step 4** On the resulting **Device Command** page of the **Add Device Command Widget** window, click the **Choose** button to the right of the **Single** device radio button.

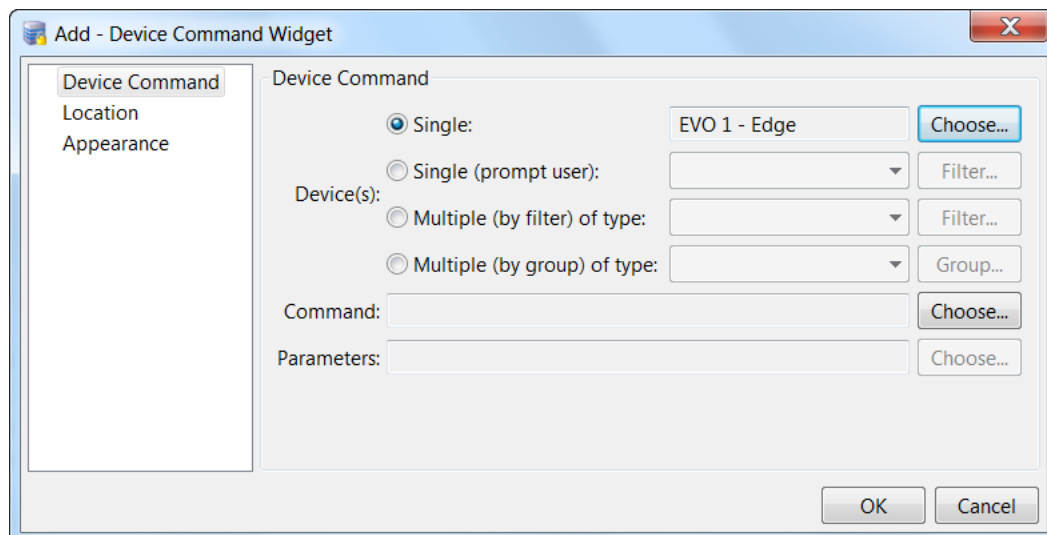

- Step 5** In the resulting **Choose Device** dialog, select the **Automation Driver** from the Hardware - Tree view, and click **OK**.

- Step 6** Back in the **Device Command** page of the **Add Device Command Widget** window, click the **Choose** button to the right of the **Command** field.
- Step 7** In the resulting dialog, select **Invoke Automation Rule**, and click **OK**.
- Step 8** Back in the **Device Command** page of the **Add Device Command Widget** window, click the **Choose** button to the right of the **Parameters** field.
- Step 9** In the resulting dialog, select a parameter from the list, and click **OK**.
- Step 10** Back in the **Add Device Command Widget** window, switch to the **Location** page, and specify the desired position for this new button.
- Step 11** Switch to the **Appearance** page, and specify the text label and icon image that will appear on the button for this device command.
- Step 12** Click **OK** to save your changes and close the window.

See [Configuring Global I/O Automated Rules, page 13-18](#) for more information.

---

## Creating Panels (Windows) of Related Buttons

---

- Step 1** Create one or more Quick Launch buttons.
- Step 2** Select **Save** or **Save As** to save the current Quick Launch window as a panel.
- Step 3** In the resulting **Save Panel** dialog, type the panel name, and click **OK**.

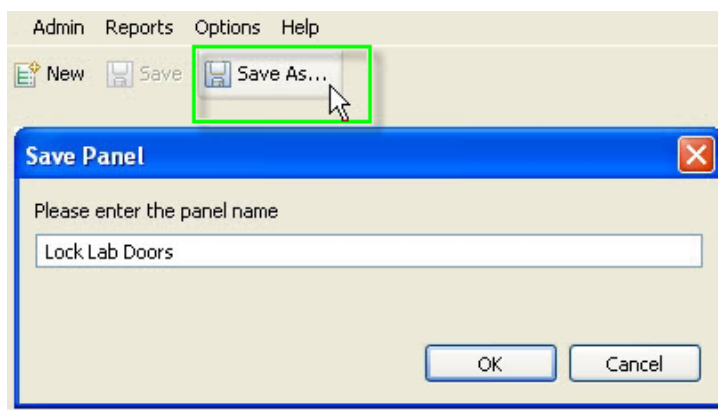

### Tip

To toggle between the existing panels, select **Panels** from the menu bar, and select a panel.

---

## Restricting User Access to Button Panels

You can restrict user access to the button panels (using the **Profiles** and **Logins** modules), as described in the following instructions.

- Step 1** Create or modify profiles to include the required Quick Launch access privileges. (Profiles are sets of access privileges that are assigned to individual user logins.)
- Choose the **Users > Profiles** command.
  - On the toolbar of the resulting **Profiles** main window, click the **Add** button to create a profile, or click the **Edit** button to modify a profile.
  - If you are adding a profile, in the resulting New Profile dialog, select a **Template** to use as the basis of the new profile, and click **OK**.
  - On the resulting **Add Profile** or **Edit Profile** window, click the **Modules** tab.
  - On the **Modules** page, expand the tree on the left, locate the **Quick Launch** item, and click on it.
  - Specify the profile's access privileges, using the options on the right:
    - **Allow access to module:** allow profile users to access the Quick Launch module.
    - **Allow edit:** allow users to create and edit buttons.
    - **Allow all panels:** allow access to all panels. Uncheck this option to enable the following button.
    - **Choose allowed panels.** select the panels that can be accessed by this profile.
  - Click **Save and Close**.

**Tip** For more information, see [Chapter 4, “Configuring User Access for the ICPAM Desktop Client”](#).

- Step 2** Assign the profile to the user login.
- Choose the **Users > Logins** command.
  - On the toolbar of the resulting **Logins** main window, click the **Add** button to create a user login, or click the **Edit** button to modify a user login.
  - On the resulting **Add Login** or **Edit Login** window, click the **Profiles** tab.
  - On the **Profiles** page, select the profile that includes the required access privileges.

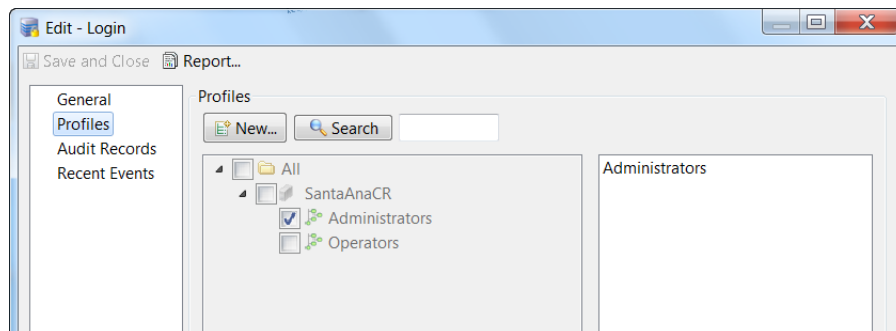

- Click **Save and Close**.

For more information, see the [“Creating User Login Accounts and Assigning Profiles”](#) section on page 4-9.



## Using Quick Launch Buttons

You can use a quick launch button to execute one or more actions:

- 
- Step 1** From the **Events & Alarms** menu, select **Monitoring > Quick Launch**.  
The **Quick Launch** window appears, with all of the currently defined Quick Launch buttons, which may be organized onto multiple panels. For more on defining these buttons, refer to [Creating a Button](#), page 13-2.
- Step 2** Double-click a button to trigger the action defined by that button.
- 

## Configuring Edge Policies

Use **Edge Policies** to create event-based actions that are stored and executed on specific controllers. These policies can trigger URL Actions that perform tasks in external devices. For example, when a user swipes their badge at a reader device, a URL action can be sent to the Cisco VSM system to start recording surveillance video for that location.

### Differences Between Edge Policies and Global I/O Triggered URL Actions

- Edge Policies are stored on the controller, and are triggered immediately when an event occurs, even if network communication with the ICPAM server is delayed or lost.
- Global I/O rules might not execute immediately due to network delays, rules processing, communication between ICPAM and the controllers, or other factors.
- Global I/O rules, however, offer additional options for automation rule triggers and subsequent actions. In addition, URL Actions for an Edge Policy are limited to the subset of events that can be triggered by the controller.

See [Configuring Global I/O Automated Rules](#), page 13-18 instructions to create global automation rules.

### Procedure

Complete the following instructions to create or modify edge policies:



**Note** This example assumes that the controllers, readers, doors, personnel accounts, and other components are installed, configured, and working properly. For instructions, see the other chapters in this guide, including [Chapter 7, “Adding New Doors”](#) and [Chapter 9, “Configuring Personnel and Badges”](#).

---

- Step 1** Enable the Edge Policy menu.
- a. Select **System Configuration** from the Admin menu.
  - b. On the resulting **System Configuration** window, select the **Advanced Setting** tab.

- c. Select the check box for the **Enable “Edge Policies” Module** option.

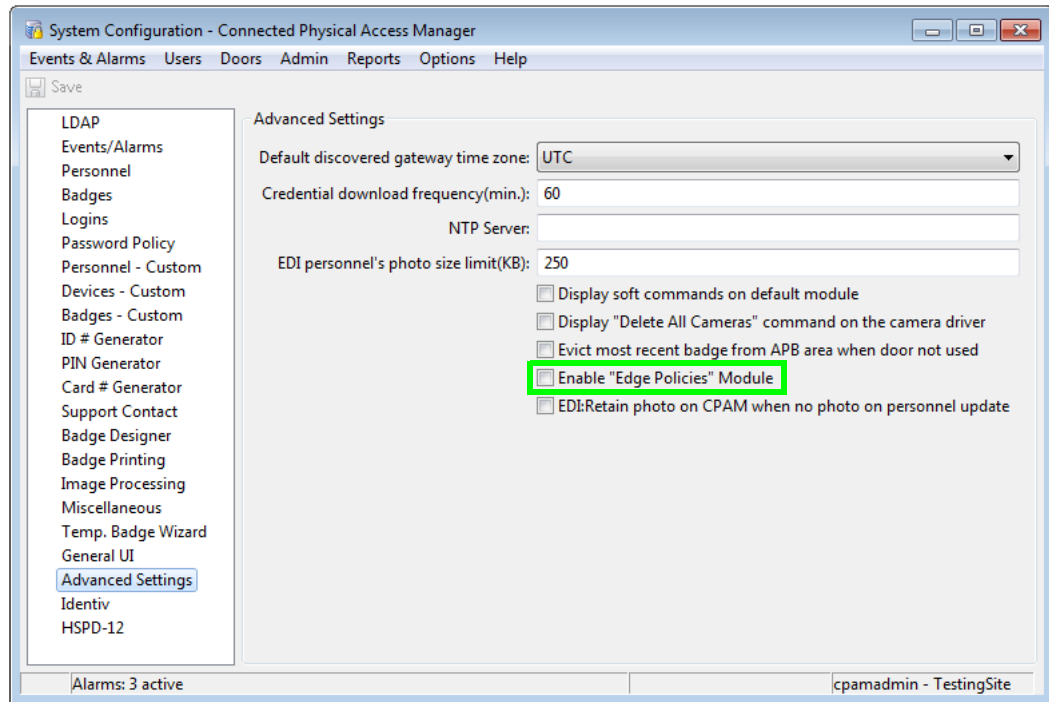

- d. Click **Save**.
- e. Log out (select **Logout** from the Options menu), and then log back in to the ICPAM application to activate the changes.

**Step 2** Select **Doors > Edge Policies > Edge Policy**.

**Step 3** On the resulting **Edge Policy** window, either click **Add**, or select an existing rule and click **Edit**.

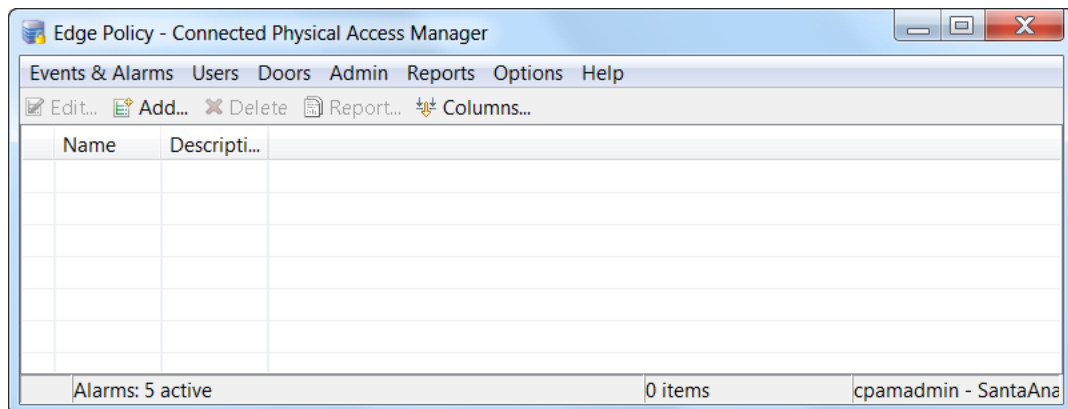

For this example, we'll add a new edge policy.

**Step 4** In the resulting **Add Edge Policy** window, type a **Name** and a **Description** for this new policy.

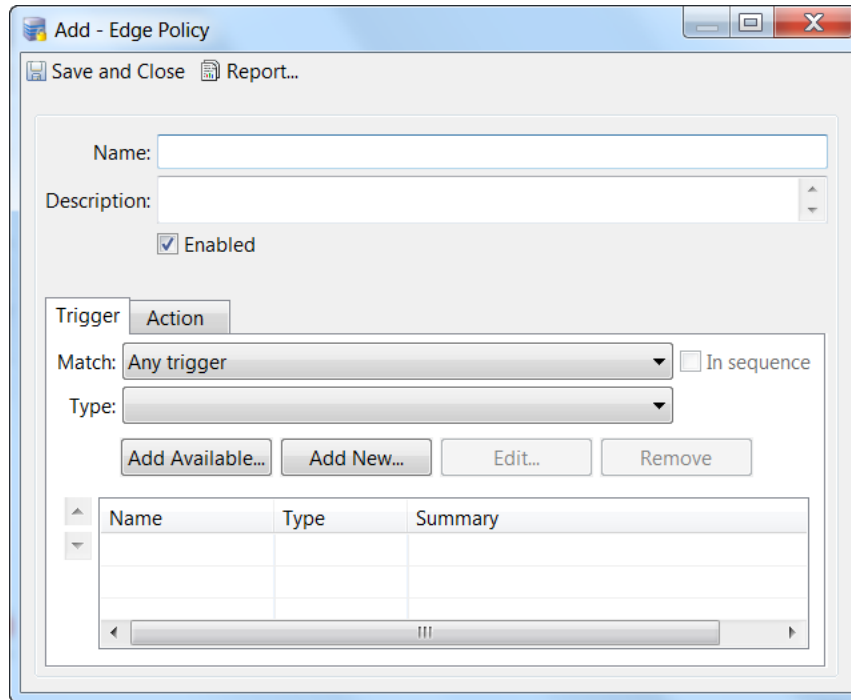

**Step 5** To activate the new policy, select the **Enabled** checkbox; to deactivate the new policy, de-select the **Enabled** checkbox.

**Step 6** On the **Trigger** tab, define the trigger. A *trigger* consists of an event (such as Door Grant Access) and a set of devices (such as a controller). When the specified event occurs on a specified device, the Edge Policy's *action* is triggered.

- In the **Match** drop-down list, select **Any trigger**.
- In the **Type** drop-down list, select **Event**.
- Click **Add New** to select the event and device(s) used to trigger the rule.



**Tip** You can also use the **Add available** button to choose a previously defined trigger (condition). To create, edit, or delete the saved triggers, select **Doors > Edge Policies > Conditions**.

**Step 7** On the **General** page of the resulting **Add Condition** window:

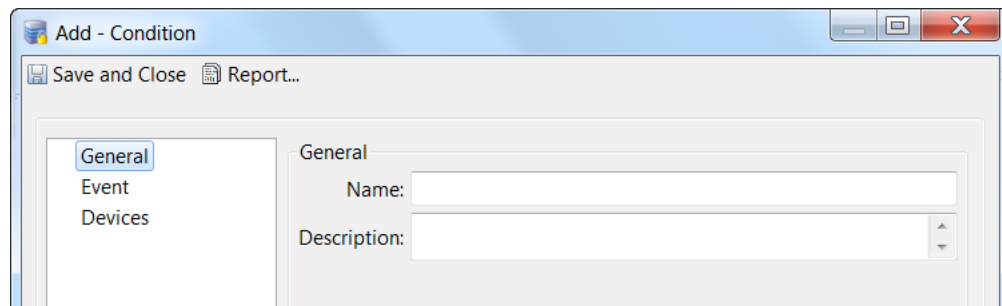

- Type a meaningful **Name** for this trigger condition. For example, *Access Lobby Door*.
- Type the trigger condition's **Description**. For example, *Access Door event at lobby door*.

- c. Switch to the **Event** page and select the event for the trigger:

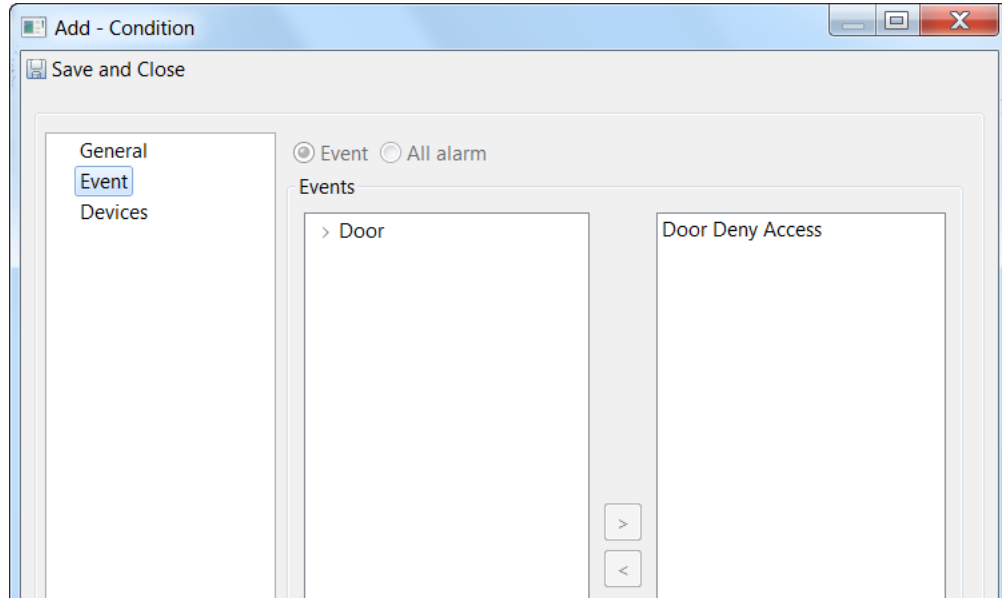

Select an event from the left column, then move it to the right column by clicking the top button .

- d. Switch to the **Devices** page and specify the devices that the event must occur on:

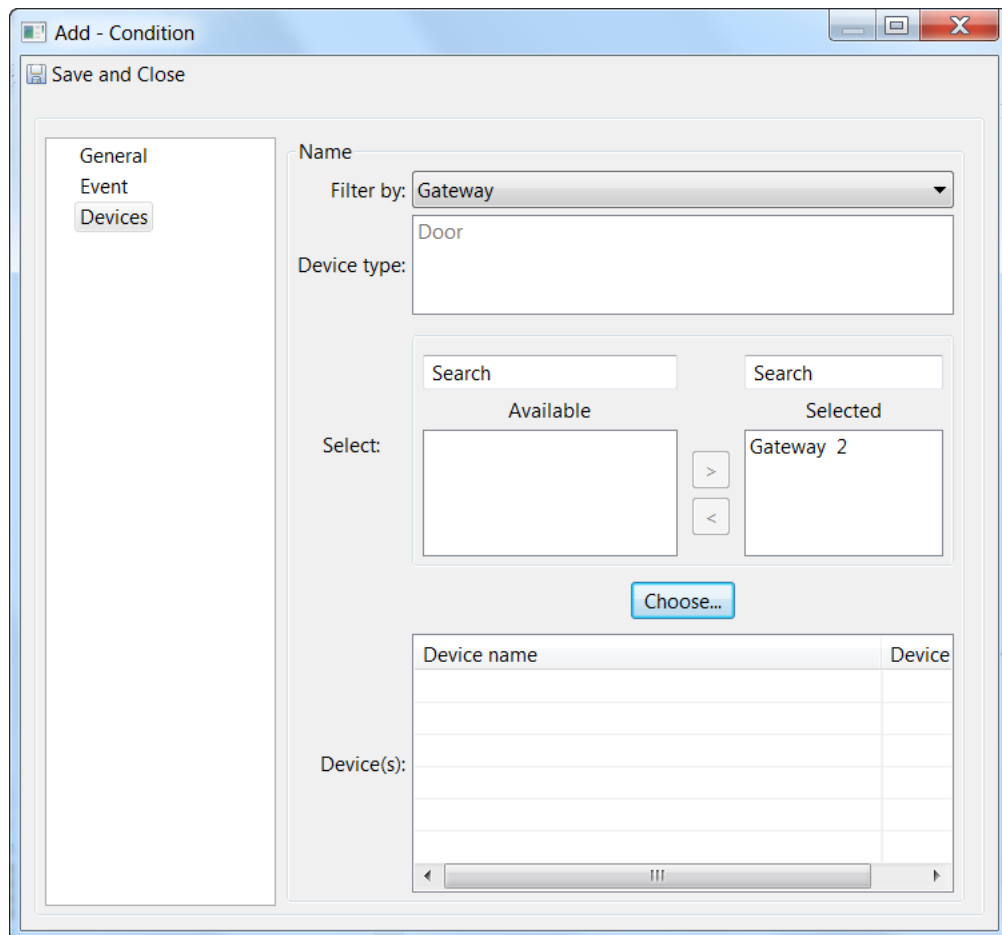

- Filter by—select the device. For example, **Gateway**.
  - Device Type—shows the available device types. For example, Door.
  - Select—highlight a device in the *Available* column, and click the arrow to move it to the *Selected* column.
  - Device(s)—click *Choose* and select an available device (such as a Door) and move it to the *Selected* field.
- e. Verify that the selected device name appears in the Devices field.
- f. Click **Save and Close**.
- Step 8** Back in the **Add Edge Policy** window, switch to the **Action** page, and specify the action that will be performed when the trigger condition(s) are met.

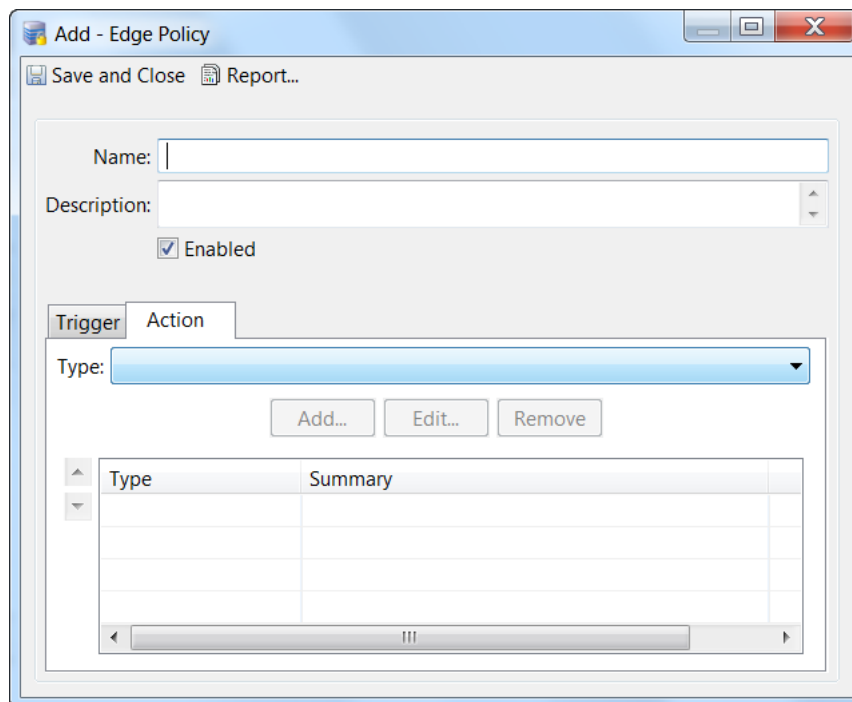

- URL Action—select a URL Action that will occur when the conditions are met. See the “[Configuring URL Actions](#)” section on page 14-2. The URL action must be an Edge action type.

**Note** For Cisco VSM video recording, create a *soft trigger* event in VSM to generate the URL used to record video. Enter that URL in the URL action.

- Step 9** Click **Save and Close** to save the changes.

The new or revised policy is displayed in the main window.

- Step 10** Right click on the affected controller, and choose the **Apply Configuration Changes** command from the pop-up menu to activate the rule. (See [Applying Configuration Changes](#), page 7-14 for more information.)



**Note** The controller must be in the Up state, signified by a green triangle in the icon. A dark green triangle means there are configuration changes that have not been applied.

## Configuring Device I/O Rules

Use the **Device I/O Rules** module to create event-based rules for a specific controller and the doors and devices configured on the controller. For example, when a door is forced open, a rule can activate a generic output device to sound an alarm. Because device rules are implemented for a single controller, the action is triggered immediately.

Device automation rules differ from global automation rules (global I/O) in the following ways:

- Device rules affect a single controller, while Global I/O rules can affect multiple controllers.
- Device rules trigger actions immediately because they are executed on the controller, so they are not subject to system or network delays. Global I/O rules might not execute immediately due to network delays, rules processing, communication between ICPAM and the controllers, or other factors. See [Configuring Global I/O Automated Rules, page 13-18](#) instructions about creating global rules.

Complete the following instructions to create or modify device I/O rules.

**Step 1** Select **Device IO Rules** from the **Doors** menu.

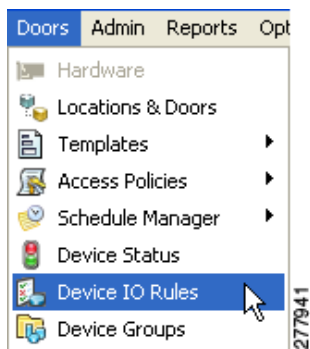

**Step 2** On the resulting **Device IO Rules** window, either click **Add**, or select an existing rule and click **Edit**.

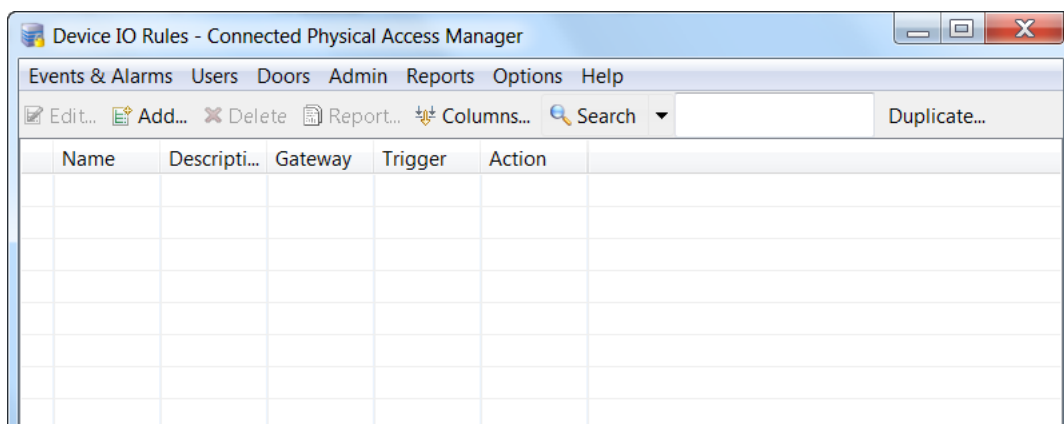

- To duplicate an existing rule:
  - Select an entry in the table, and click the **Duplicate** button on the right side of the toolbar.
  - In the resulting dialog, type a **New Name** for the rule, and click **OK**.
  - Back in the **Device IO Rules** window, select the duplicate rule name in the table, and click **Edit**.
  - Revise the rule settings, as described in the following steps.

**Step 3** In the resulting **Add Device IO Rule** or **Edit Device IO Rule** window, specify the rule settings:

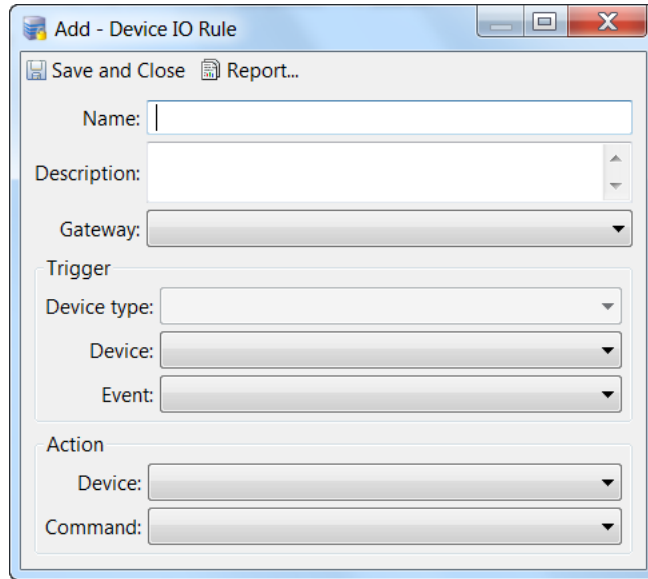

- **Name:** type the name of the rule.
- **Description:** type a short description of the rule.
- **Gateway:** select the controller or gateway where the device is installed.

**Trigger:**

- **Device Type:** select the device type; the choices are Door, Generic Input device, Glass Break Sensor, Motion Sensor, Duress Sensor, Fire Sensor, Tamper device, or Power Fail device.
- **Device:** select the device name.
- **Event:** select the event. When this event occurs on the selected device, the following action is performed.

**Action:**

- **Device:** select the device for the action.
- **Command:** Select the device command. For more information, see [Device Commands, page 7-46](#).

**Step 4** Click **Save and Close** to save the changes.

The new or revised rule is displayed in the **Device IO Rules** main window.

**Step 5** Select **Apply Configuration Changes** on the affected controller to activate the rule.

See [Applying Configuration Changes, page 7-14](#) for more information.



**Note** Controllers must be in the Up state, signified by a green triangle in the icon. A dark green triangle means there are configuration changes that have not been applied.

## Configuring Global I/O Automated Rules

Automated rules can execute commands, generate event reports, edit multiple records, or perform URL actions. After it has been created, you can invoke the automated rules from other modules, such as Quick Launch buttons or the Maps Editor.

A Global I/O rule is comprised of a trigger and an action.

The *trigger* can be one of 3 types:

- Periodic
  - Monthly—the day of the month and time the action occurs
  - Weekly—the day of the week and time the action occurs
  - Daily—the time of the day the action occurs
- Manual
  - The action only occurs when manually invoked by a user.
- Event
  - The action occurs only when specified criteria are met.

The *action* occurs when the trigger conditions are met. The options are to generate a report or issue a device command.

You create automated tasks using the Global I/O module, as described in the following sections.

- [Enabling the Automation Driver, page 13-18](#)
- [Configuring Automated Tasks Using Global I/O, page 13-20](#)
- [Global I/O Example: Automated Weekly Report, page 13-29](#)

## Enabling the Automation Driver

To enable automated tasks, the Automation Driver must be created and configured in the Hardware - Tree window. The driver is created once, and then remains active unless deactivated.



**Tip**

The Automation Driver is a system component that executes automation policy actions. See [Viewing Doors and Devices in the Hardware Tree View, page 5-4](#) for a description of the various system drivers.

**Step 1** Select **Hardware - Tree** from the **Doors** menu.

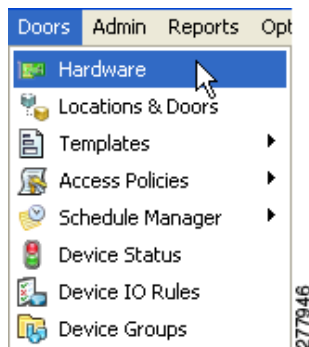



**Step 2** Right-click the **Driver Manager** and select **New Automation Driver...**



**Step 3** Enter the driver settings:

- a. Click the **General** tab and enter a **Name** for the **Automation Driver**.

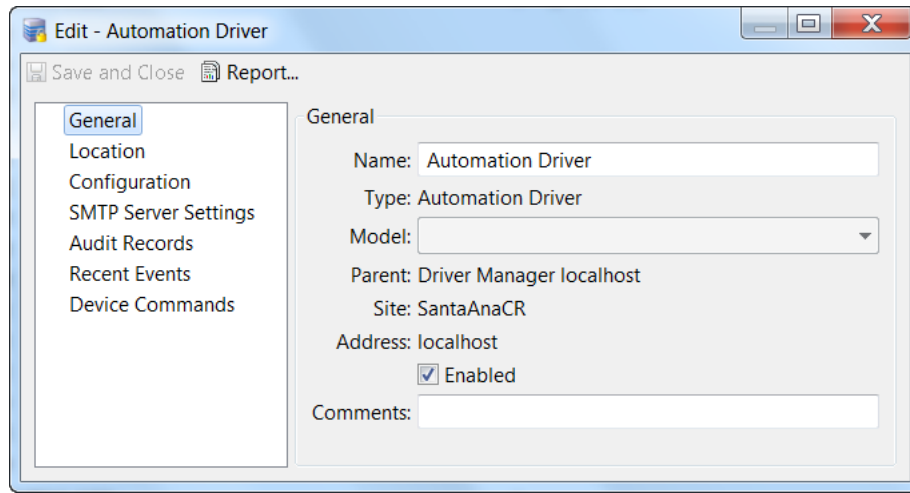

- b. If e-mail notification is needed, switch to the **SMTP Server Settings** page, and enter the SMTP server settings.
- c. Click **Save and Close** to close the configuration window and create the Automation Driver.

**Step 4** Right-click the **Automation Driver** and select **Start**.

This enables the driver and activates any automated rules.

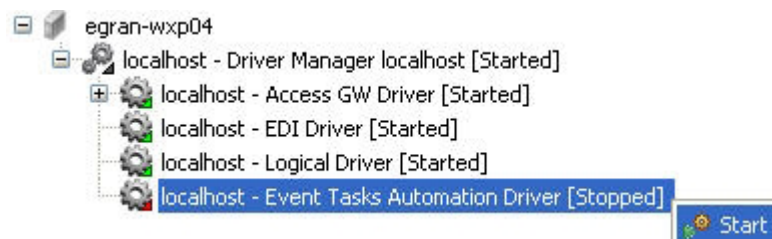

## Configuring Automated Tasks Using Global I/O

Create automated rules to automatically execute commands or generate event reports. The automated rules can also be configured for manual use, which is useful when placing a task icon in a graphic map.

**Step 1** Select **Global I/O** from the **Events & Alarms** menu.

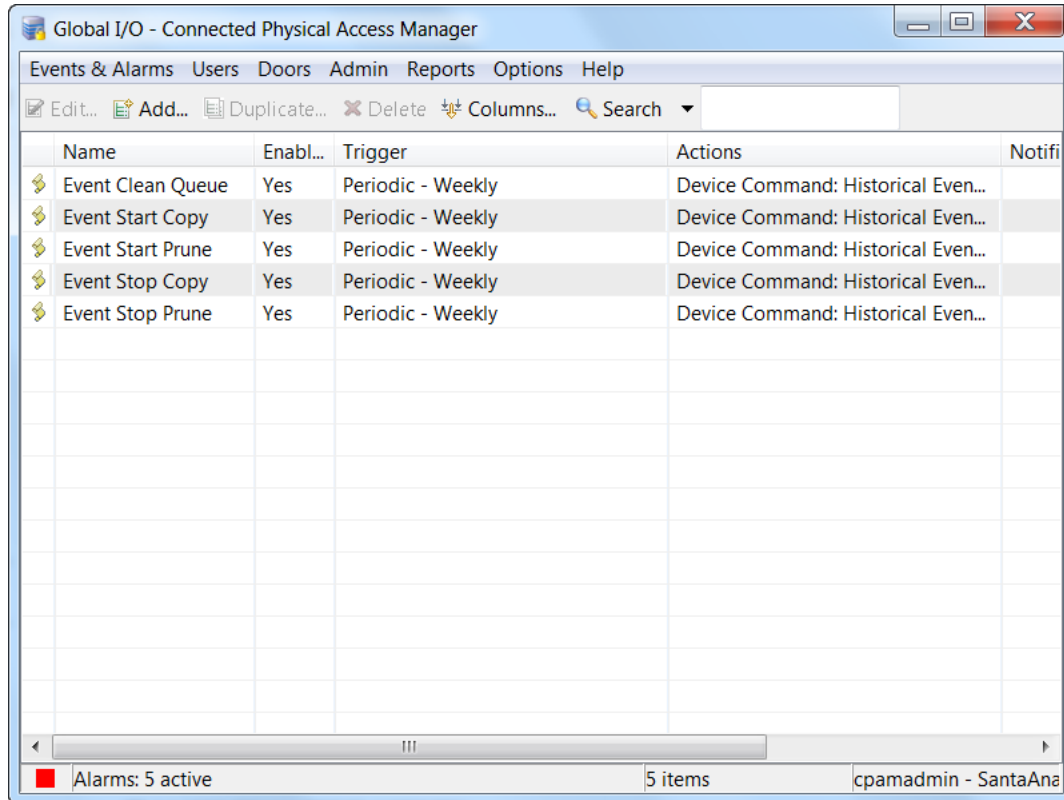

The resulting window lists the currently defined rules, and includes the following columns.

- **Name:** The name of the automated task.
- **Enabled:** `yes` if the task is enabled. `no` if the task is disabled.
- **Trigger:** Operator-defined events, and or time schedules that execute an action or notification.
- **Actions:** Reporting or device commands executed on devices.
- **Notification:** The notification type. For example: E-mail, FTP, or Syslog notification.

**Step 2** Click **Add**, or select an existing rule and click **Edit**.



**Tip** You can also right click on an item in the table to display a pop-up menu of commands.

**Step 3** In the resulting **Add Automation Rule** or **Edit Automation Rule** window:

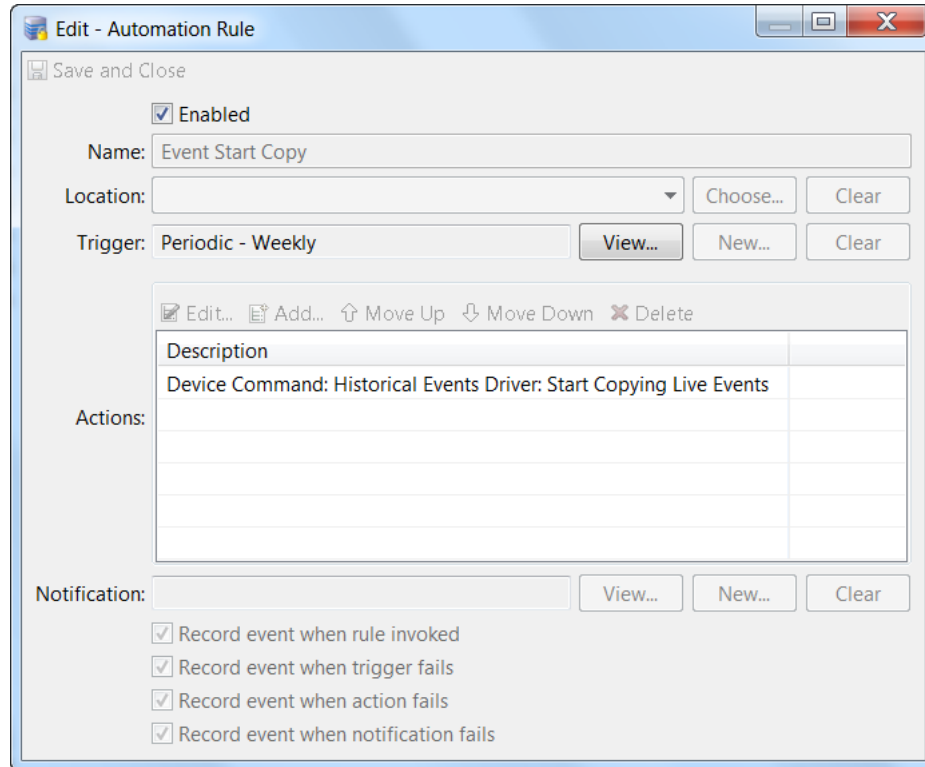

- a. Select or deselect the **Enabled** check box.
- b. Type a **Name** for the rule.
- c. (Optional.) Specify the **Location**.
- d. Click **New** or **Edit**.
- e. In the resulting dialog, select the trigger's **Type** for the rule, then click **OK**. The choices are:

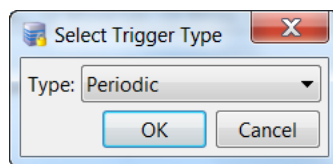

- **Event:** The rule is invoked when an event matching the defined filter occurs.
  - Select **Event**.
  - Click **Edit Filter** to define the filter.
  - Select a **Time Schedule** for the rule. If the event occurs within the specified schedule, the rule will be invoked. See [Configuring Time Schedules](#), page 12-43 to define the schedules.
- **Periodic** (time schedule): The rule is invoked according to a **Monthly**, **Weekly**, or **Daily** schedule. Select the day of week or day of month, if necessary, and specify the **Time of day** (in the 24-hour format).
- **Manual Only:** The rule is invoked manually. You can create a Quick Launch button or add the rule to a graphic map.

**Step 4** Define one or more **Actions** that occur when the rule is triggered. The action types are:

- **Report:** Generates a report that can be saved or sent to a user.
- **Device Command:** Executes a command on a specified device.
- **CSV Import:** Imports a *comma separated value* file containing personnel or organization data. The file must be located on an FTP server or an ICPAM server.
- **Group Edit:** Edits multiple personnel or badge records.
- **Delay:** Shows the time of delay between two actions performed in the Global I/O.
- **External Command:** An External command is used to run a exe file or application on server from Global I/O.
- **Sanity Report Action:** Provides a snapshot of the system status.
- **URL Action:** performs a pre-defined URL action.

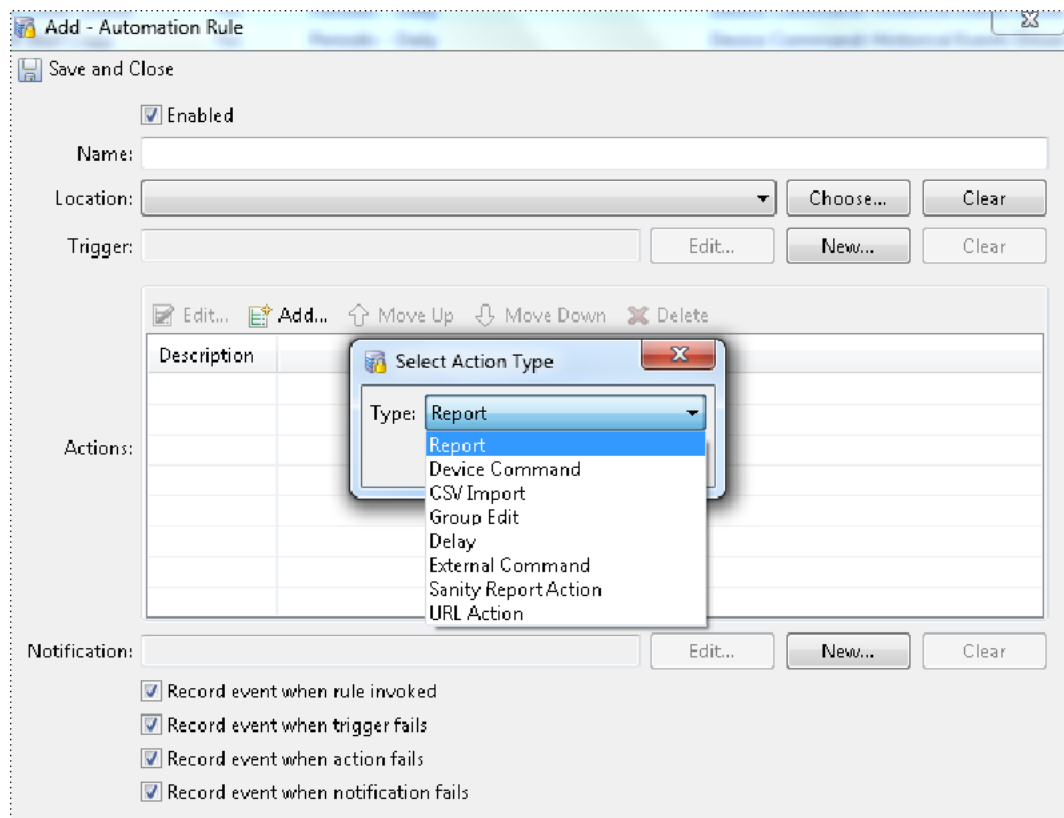

**Tip** See [Understanding Automated Rule Actions, page 13-23](#) for descriptions of the fields and settings for each option.

**Step 5** Specify the **Notification** destination that defines where the notification or report file will be sent. The choices are:

- **E-mail:** Sends the notification or report file to one or more e-mail addresses. To enable e-mail notifications, you must enter the SMTP server settings in the Automation Driver. For instructions, see [Step 3 in Enabling the Automation Driver, page 13-18](#).

- **FTP:** Sends the file to the specified FTP server.
    - **Host:** The FTP server IP address or name.
    - **Username:** Log in username required by the FTP server.
    - **Password:** Password to log in to the FTP server.
    - **Path:** Path on the FTP server where files should be uploaded.
  - **Syslog:** Sends the notification or report to a Syslog.
    - **Host:** The Syslog server IP address or name. You must verify that the server is accessible and allows remote hosts to log messages. ICPAM does not verify the Host server availability.
    - **Facility:** The log facility to use when recording the information to the Syslog.
- Step 6** Select the desired notification recording options, by clicking the check boxes to activate or deactivate the options:
- **Record event when rule invoked:** Each time the rule is invoked, record an event.
  - **Record event when trigger fails:** Each time the trigger fails, record an event.
  - **Record event when action fails:** Each time the action fails, record an event
  - **Record event when notification fails:** Each time the notification fails, record an event.
- Step 7** Click **Save and Close**.
- 

## Understanding Automated Rule Actions

Automated rule actions define what occurs when a rule is triggered. The actions are defined when creating or editing a rule, as described in [Configuring Automated Tasks Using Global I/O](#), page 13-20.

This section provides details about the following action types for automated rules:

- **Report:** Generates a report that can be saved or sent to a user.
- **Device Command:** Executes a command on a specified device.
- **CSV Import:** Imports a *comma separated value* file located on an FTP server or ICPAM server. The file can contain personnel or organization data.
- **Group Edit:** Edits multiple personnel or badge records.
- **Sanity Report Action:** Provides a snapshot of the specified system status.
- **URL Action:** performs a pre-defined URL action.

In the **Actions** section of the **Add Automation Rule** or **Edit Automation Rule** window, either click **Add** to create a new action, or select an existing action and click **Edit**.

## Report

Generates a report that can be saved or sent to a user. Complete the following settings:

- Select the Action type of **Report**.
- Click **Choose** to select a pre-defined report template. To create or modify reports, see [Defining Reports \(Report Manager\)](#), page 13-36.
- Click **Settings** to define the report:

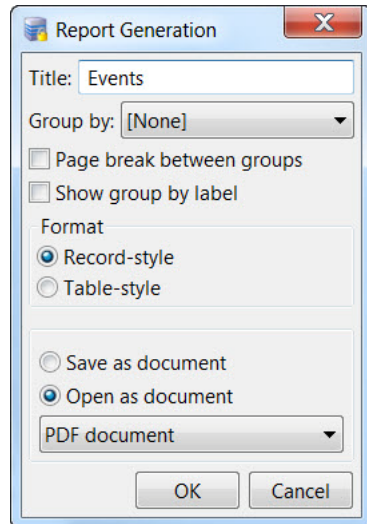

- **Title**: edit the name of the report, if necessary.
- **Group by**: select the group, if available.
- **Page break between groups**: select this option to have each group start on a new page.
- **Show group by label**:
- **Format**: select **Record-style** or **Table-style**.
- Output type: select an output type from the drop-down menu. For example: **PDF document**.

### Device Command

Executes a command on one or more devices.

- a. Select the Action type of **Device Command**.

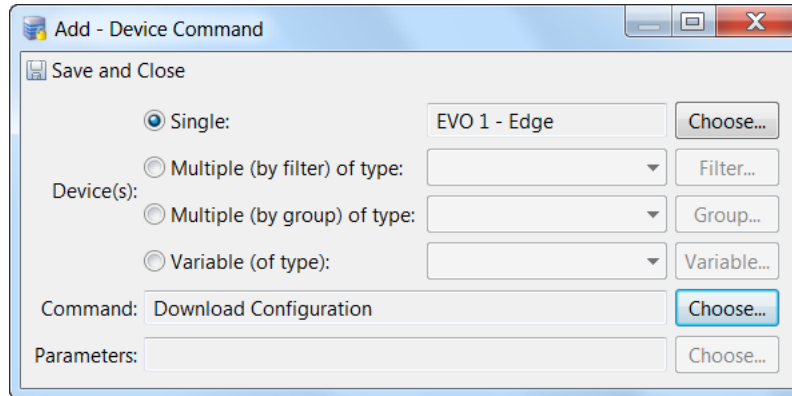

- b. **Device(s):** Select the Device(s):

- **Single:** click **Choose** and select a single device or door from the Hardware - Tree view.
- **Multiple (by filter) of type:** select a device type from the drop-down menu. For example, select **Deadbolt** to select all deadbolt devices in all doors. To refine the selection, click **Filter** and select the filter options.
- **Multiple (by group) of type:** select a device group from the drop-down menu. To create door groups, see [Configuring Device Groups, page 7-24](#).
- **Variable (of type):** select a device type from the drop-down menu, and then click **Variable** to select a variable.

For example, select the variable type **Door**, and then click the **Variable** button. Select **Triggering Event: Device** from the drop-down menu, and click **OK**.

- c. **Command:** Click **Choose** to select the command for the device(s). See [Device Commands, page 7-46](#) and [Door Modes and Commands, page 7-47](#) for command descriptions.

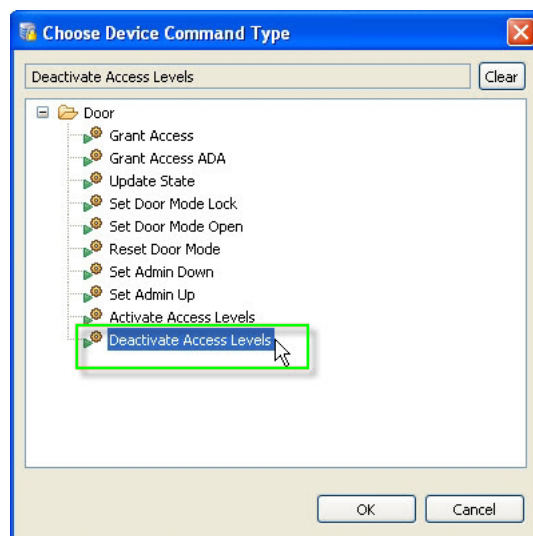

- d. If required, specify the parameters for the selected command:
  - If the **Choose** button to the right of the **Parameters** field is enabled, you must click that button to continue. In the resulting dialog, select a parameter from the list, and click **OK**.
  - If a message dialog asking “*Are you sure you want to continue?*” appears, click **OK**. This message indicates that a parameter is not required.
- e. Click **Save and Close**.

### CSV Import

Imports a *comma separated values file* from a directory located on the ICPAM Server or an FTP server.

- The properties import file must be named `csv.import.properties`.
  - Do not include the header row in CSV import files. Otherwise, the header row is imported as data and results in one record more than the correct count.
  - To import pictures, the path name in the CSV file should be relative to the **Directory path** for the CSV properties file. If only the image name is specified in the CSV file, then the images must be located in the same directory as the CSV properties file.
- a. Select the Action type **CSV Import**.
  - b. Select the data **Type**: Personnel or Organizations.
  - c. **For CSV import from ICPAM server** enter the file settings as:
    - Directory Path: The directory path of the CSV file location in ICPAM server.
    - Configuration file: (read only) the import configuration file having import mapping settings must be named `csv.import.properties`.

**Note** Here the CSV file and `csv.import.properties` should be placed in any of the ICPAM server directories like `/tmp` or `/directory` that has root level permissions. Ensure that both files are in the same directory path.

- d. Click **Save and Close**.
- e. **For CSV import from folder/directory located on a FTP server**, enter the server and file settings as:
  - Host: the IP address of the FTP server.
  - Username: the username required for access to the FTP server.
  - Password: the FTP server password.
  - Directory path: the directory path for the file location.
  - Configuration file: (read only) The import configuration file having import mapping settings, must be named as `csv.import.properties`.

**Note** The `.csv` and `csv.import.properties` files should be placed in the location specified in the Directory path.

- f. Click **Save and Close**.

For CSV import for personnel records from local client machine desktop, See [Importing Personnel Records Using a Comma Separated Value \(CSV\) File](#), page 9-14.



### Group Edit

Edits multiple personnel or badge records.

- a. Select the Action type of **Group Edit**.

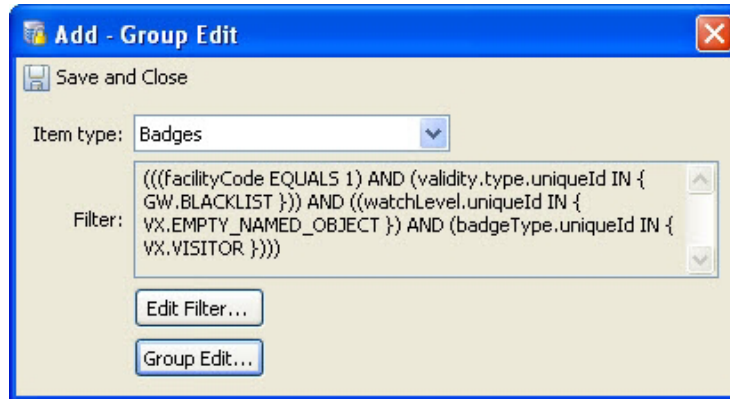

- b. Select the **Item type**: for example, **Badges**.
- c. (Optional) Click **Edit Filter** to apply the changes to a filtered subset of badges or records. Use the filter window to define the filter settings.
- d. Click **Group Edit** to specify the changes that will apply to all selected personnel or badge records.
- e. Click **Save and Close**.

### Sanity Report Action

System sanity reports provide information about potential system inconsistencies or issues in the access control system. See [Generating a Gateway Driver System Sanity Report, page 5-18](#) for more information.

- a. Select the Action type of **Sanity Report Action**.

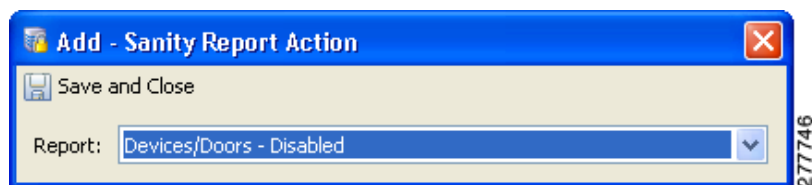

- b. Select the **Report type**: for example, **Devices/Doors - Disabled**.
- c. Click **Save and Close**.

**URL Action**

Performs a pre-defined URL action.

- a. Select the Action type of **URL Action**.

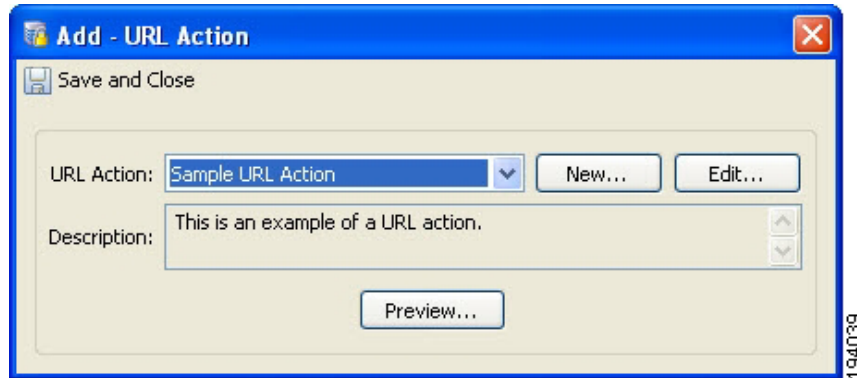

- b. Select a pre-defined **URL Action** from the drop-down menu.
- c. (Optional) Click **New** or **Edit** to create or modify an URL action. See [Configuring URL Actions, page 14-2](#) for more information.
- d. Click **Save and Close**.

**Tip**

Static URL actions can be invoked by creating a manual automated rule. Set the Trigger Type to **Manual** and the Action Type as **URL Action**. Then select a static URL from the list. This rule can be invoked by right-clicking on the Automation Driver in the Hardware - Tree module and selecting **Invoke Automation Rule**. You can also create a Quick Launch button to invoke the rule (see [Creating Quick Launch Buttons, page 13-2](#)).

## Global I/O Example: Automated Weekly Report

The following example shows how to configure an automated rule that runs a report on a weekly basis.

- Step 1** Select **Global I/O** in the Events & Alarms menu.
- Step 2** Create a new automated rule and specify its general settings:
- Click **Add...** to open the **Add Automation Rule** window.

- Enabled:** Verify that the **Enabled** check box is selected.
  - Name:** Type a descriptive name for the rule. For example: `Daily Gateway Report (output)`.
- Step 3** Specify the Periodic trigger type, to have the report generated at a regularly scheduled time:
- Click the **New...** button on the right of the Trigger field.
  - In the resulting Select Trigger Type dialog, select **Periodic** from the drop-down menu, and click OK.

**Step 4** In the resulting dialog, select the days and times for the periodic trigger:

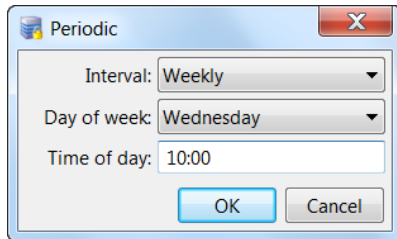

- a. **Interval:** Options include: **Monthly**, **Weekly**, and **Daily**.
- b. **Day of Week/Month:** If you select **Monthly** or **Weekly**, select the day of the month or week.
- c. **Time of day:** Enter a time using 24-hour notation. For example, 1:00 p.m. in a 12-hour clock is expressed as 13:00 in a 24-hour clock.
- d. Select **OK**.

**Step 5** Specify the action to generate a report file:

- a. In the **Action** section, click the **Add...** button.
- b. In the resulting **Select Action Type** dialog, select **Report** from the drop-down menu, and click **OK**.

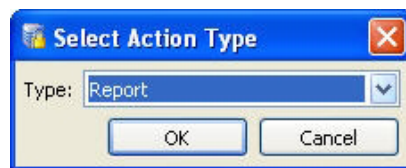

**Step 6** In the resulting **Report** dialog, define the type of report and the format of the output:

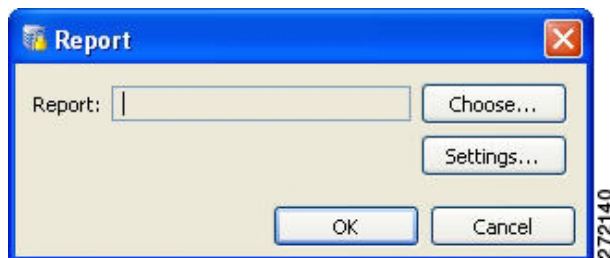

- a. Click **Choose...**
- b. In the resulting **Choose Report** window, select a report from the list, and then click **OK**.



**Tip** To create or edit reports, see [Defining Reports \(Report Manager\)](#), page 13-36.

- c. Back in the **Report** dialog, click **Settings**.

- d. In the resulting **Report Generation** dialog:

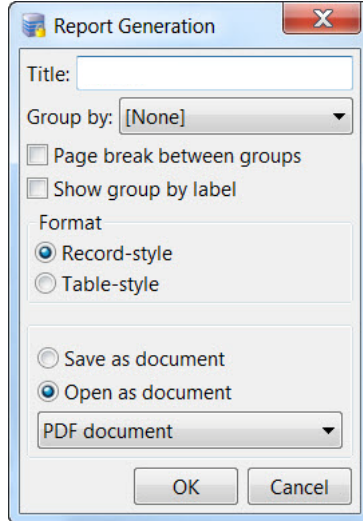

- **Title:** Type the title for this report.
- **Group by:** select the group, if available.
- **Page break between groups:** select this option to have each group start on a new page.
- **Show group by label:**
- **Format:** select whether the report should be in **Record-style** or **Table-style**.
- Output type: select an output type from the drop-down menu. For example: **PDF document**.
- Click **OK** to close this dialog.

- e. Back in the **Report** dialog, click **OK**.

**Step 7** Back in the **Add Automation Rule** window, specify the Notification method. For this example, we will send the report file by e-mail:

- a. Click the **New...** button on the right of the Notification field.
- b. In the resulting **Select Notification Type** dialog, select **E-mail**, and then click **OK**.

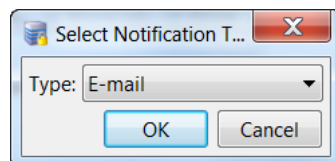

**Step 8** In the resulting **E-mail Notification** dialog:

The screenshot shows the 'E-mail Notification' dialog box. It has a title bar with the text 'E-mail Notification' and a close button. The dialog is divided into three sections: 'To', 'CC', and 'BCC'. Each section has a header with 'Edit...', 'Add...', and 'Delete' icons. Below each header is a table with a 'Value' column and an empty row. At the bottom of the dialog are 'OK' and 'Cancel' buttons.

- a. Type valid e-mail addresses in the **To**, **CC**, and or **BCC** fields. You can type specific e-mail addresses, or select addresses from the Personnel records configured in ICPAM.
- b. When you are finished, click **OK** to save the changes and close this dialog.

**Step 9** Back in the **Add Automation Rule** window, select the desired notification recording options, by clicking the check boxes to activate or deactivate the options:

- **Record event when rule invoked:** Each time the rule is invoked, record an event.
- **Record event when trigger fails:** Each time the trigger fails, record an event.
- **Record event when action fails:** Each time the action fails, record an event
- **Record event when notification fails:** Each time the notification fails, record an event.

**Step 10** Click **Save and Close**.

**Step 11** Add the Automation Driver, as described in [Enabling the Automation Driver, page 13-18](#).



**Note** This last step is only necessary if the Automation Driver has not already been added.

## Automation Rules in ICPAM 2.1

If the profile enhancement feature is set in the system configuration settings (see [Logins page of the System Configuration window, page 17-11](#)), the following changes are impacted in this module:

- The location-restricted users can create automation rules in the Global I/O interface only within their set of accessible locations. The user is allowed to add trigger conditions and actions only on devices within their assigned hierarchical location as shown in [Figure 13-1](#).

**Figure 13-1** Add Automation Rule

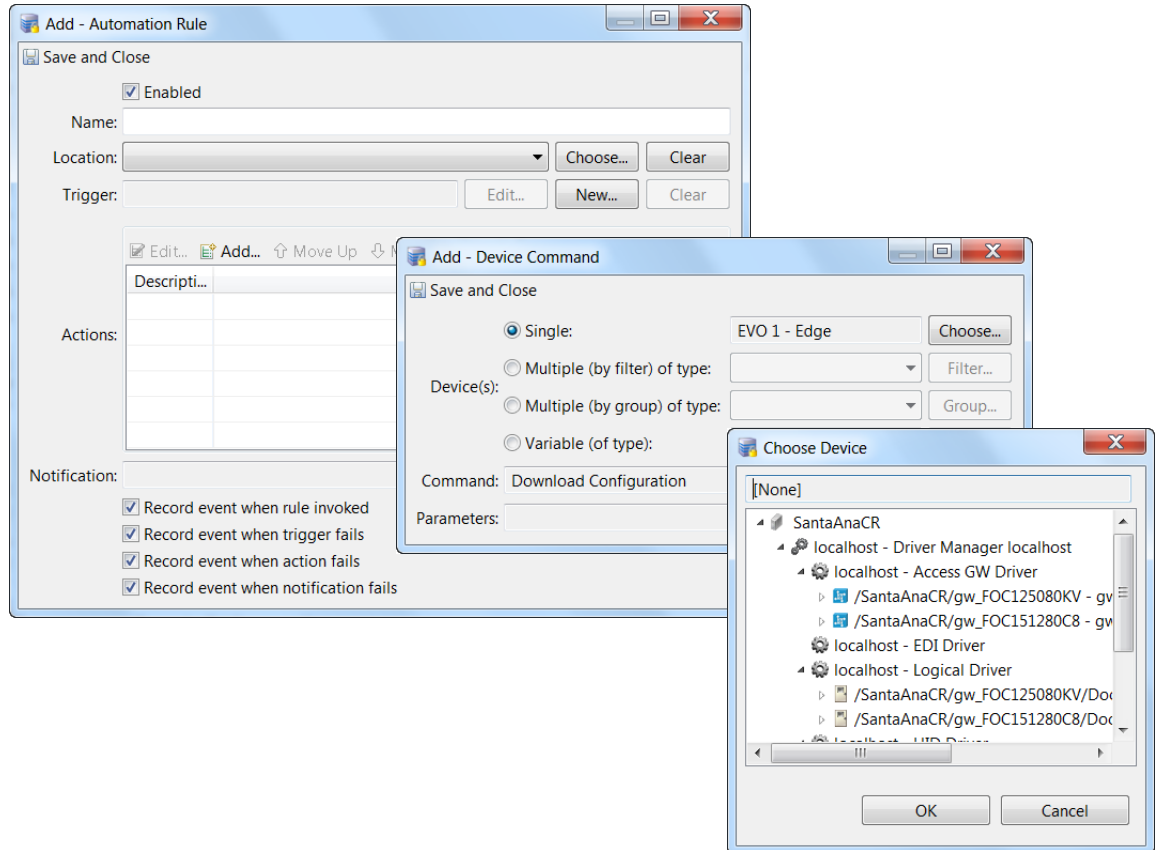

- The location-restricted user has to select the hierarchical location while adding an ‘Automation rule’, unlike other modules where the hierarchical location of the location-restricted user is auto-populated.
- When a location is assigned to a global I/O rule of trigger type Periodic and event, the rule is applied only for the location it was created to and its child nodes (if any).
- If the trigger type is manual, then the rule is applied to the locations that are common between the locations assigned to the location-restricted user and the location(with its child nodes) in which the global I/O was created.
- If the location-restricted user wishes to invoke a global I/O manually, the Automation Driver has to be present in the hardware view of the location-restricted user. To achieve this, the cpamadmin can populate the Automation Driver in the hierarchical location of the location-restricted user by modifying the profile of the user.

To populate the Automation Driver, do the following:

- Step 1** Navigate to **Profiles > Edit > General tab > Login/Logout options.**

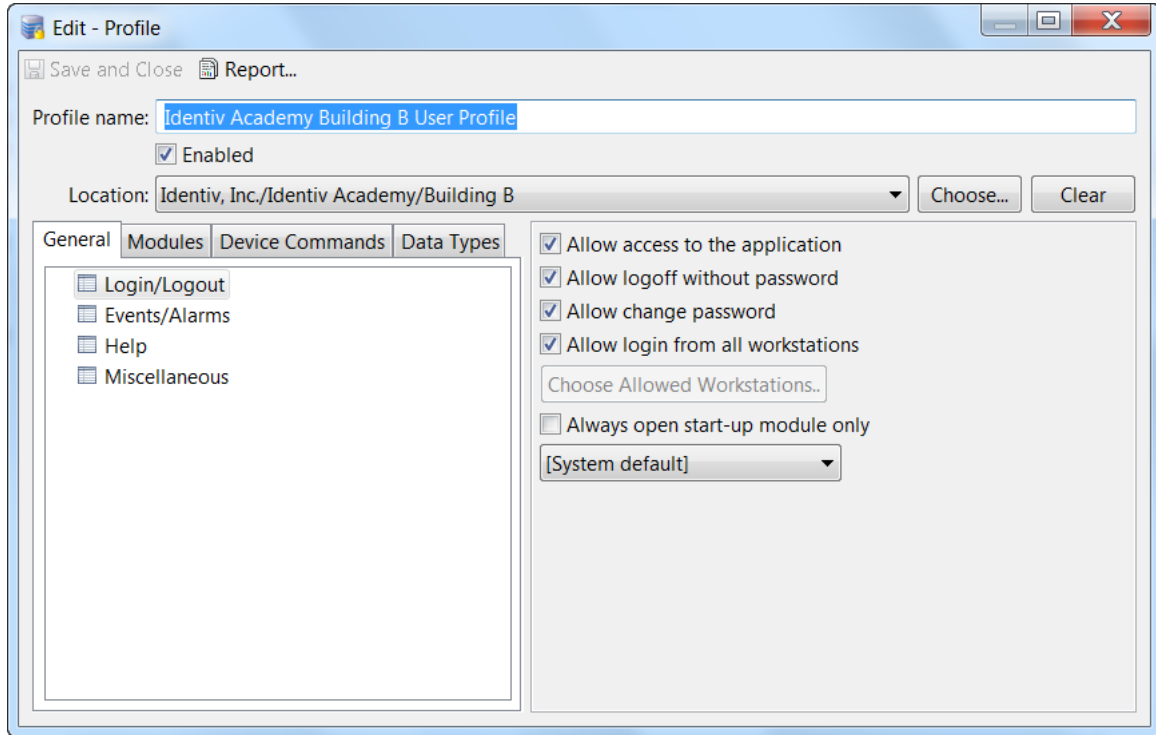

- Step 2** Select the **Ignore hierarchical location restriction for device matching filter** check box.

- Step 3** Click **Filter**.



**Step 4** In the resulting window, select Automation Driver in the Type list.

**Step 5** Click **OK** to save the changes. The automation driver is populated.



**Note**

The drawback of populating the automation driver is that the automation driver events of other locations that are not under the purview of the location-restricted user also become visible.

- All automation rules created up to the root of the hierarchy of the location-restricted user is visible to the user. The location restricted user can invoke these rules provided there are any devices (at least one) pertaining to their location in these rules.
- All device groups up to the root of the location-restricted user are visible and the user can reuse these device groups provided at least one device is present from the location restricted user's assigned location in these device groups. When these device groups are reused, the commands are applied to the devices belonging to the location restricted user's location.
- When the cpadmin removes a location from the location restricted user's hierarchy, all devices of that location is removed automatically. However if any automation rules relating to these devices are present, then it requires manual removal, so the cpadmin should ensure that they remove all associated automation rules (manually) along with the location.



**Note**

These points are applicable only when the profile enhancement feature is set on the **Logins** page of the **System Configuration** window (starting with the ICPAM 2.1 release); otherwise, the ICPAM appliance retains its behavior as in the previous version (CPAM 1.5.1).

# Defining Reports (Report Manager)

The Report Manager provides pre-defined reports to retrieve data. You can use the Report Manager to view, run, add, or modify reports. These reports can be used in automated tasks.

Report templates include the following:

## Filter-based reports

Reports defined using a filter, similar to the **Filter** toolbar button in many modules. This is the most straightforward way to define a report. Filter-based reports are generated to a user based on the hierarchical location to which the user belongs to. (For more complex reports, use one of the following SQL-based options.)

## Object SQL-based reports

Reports defined using explicit SQL that returns the unique IDs of the items to display, which are otherwise presented in a similar fashion as a filter-based report.

## SQL-based reports

Reports defined using explicit SQL.



**Tip**

See [Configuring Global I/O Automated Rules, page 13-18](#) for instructions to assign reports to automated tasks.

This section includes the following information:

- [Report Manager in ICPAM 2.1, page 13-36](#)
- [Using the Report Manager, page 13-37](#)
- [Filter-based Report Template, page 13-38](#)
- [Object SQL-based Report Template, page 13-40](#)
- [SQL-Based Report Template, page 13-41](#)

## Report Manager in ICPAM 2.1

If the profile enhancement feature is set in the system configuration settings (see [Logins page of the System Configuration window, page 17-11](#)), the following changes are impacted in this module:

- A location-restricted user can view and reuse default reports up to their root level location.
- The cpamadmin should restrict access of SQL-based reports to location-restricted users in the Profiles module. This action prevents the location-restricted users from accessing SQL-based reports.



**Note**

These points are applicable only when the profile enhancement feature is set on the **Logins** page of the **System Configuration** window (starting with the ICPAM 2.1 release); otherwise, the ICPAM appliance retains its behavior as in the previous version (CPAM 1.5.1).

## Using the Report Manager

To use the Report Manager, follow this procedure.

- Step 1** Select **Report Manager** from the Reports menu.  
The **Reports** main window appears, as shown in [Figure 13-2](#).

**Figure 13-2** Report Manager main window

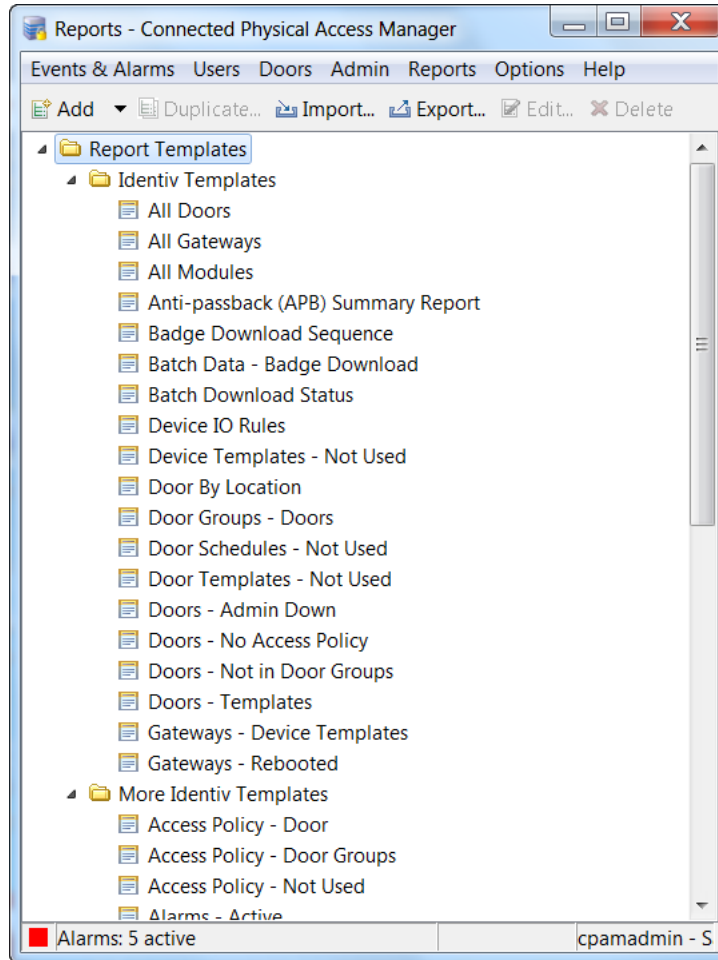

**Note** Some reports are used for internal processes and cannot be used to generate reports. For example: *Badges-Unused*.

- Step 2** Use the toolbar buttons to perform various actions.
- **Add:** Add a new report or folder. The following options are available:
    - **Add Filter-based Report Template...:** See [Filter-based Report Template](#), page 13-38.
    - **Add Object SQL-based Report Template...:** See [Object SQL-based Report Template](#), page 13-40.
    - **Add SQL-based Report Template...:** See [SQL-Based Report Template](#), page 13-41.

- **Add Folder...:** Adds a new folder for report organization.
- **Import...:** Import a previously exported report or set of reports from XML.
- **Export...:** Export all reports to an XML file, which may be later imported on the same or another system.
- **Edit...:** Select a report and click **Edit...:** to view and modify the details of the report. You can also double-click the report entry.
- **Delete:** Delete the report.
- **Run:** Run the report and open the contents of the report in a new window.

**Step 3** Edit a report using the instructions in the following sections:

- [Filter-based Report Template, page 13-38](#)
- [SQL-Based Report Template, page 13-41](#)

## Filter-based Report Template

When you add or edit a report, the **Report Manager** detail window includes properties for the specific type of report.

All report types include the following toolbar buttons:

- **Save and Close:** Save changes and close the report.
- **Run:** Run the report and open the contents of the report in a new window.
- **Export...:** Export the report to an XML file, which may be later imported on the same or another system.

Figure 13-3 shows the detail window for a Filter-based Report Template. Complete the fields according to the descriptions in Table 13-1.

*Figure 13-3 Add Filter-based Report detail window*

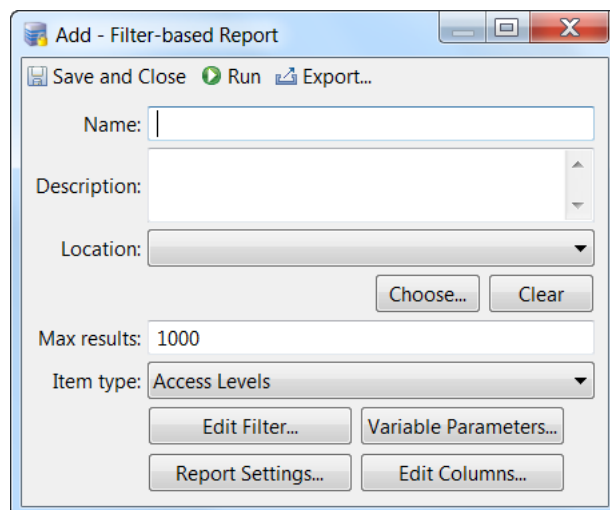

Table 13-1 Fields on the Filter-based Report detail window

Field	Description
Name	Enter a unique name for the report.
Max results	The number of results displayed in the report. The value -1 retrieves unlimited results.
Item type	The type of category to build the filter based report on.
Edit Filter...	Defines the filter, similar to filters available in the toolbar. See <a href="#">Using Filters, page 3-12</a> .
Report Settings...	Report generation options, which are the same as when generating a report from one of the other modules. For more information see <a href="#">Creating Reports, page 3-10</a> .
Variable Parameters...	Lists parameters for the report. The selected parameters will prompt the user to provide values for them when the report is run. Data will be retrieved based on the parameter values.
Edit Columns...	Select the columns used in the report. Use the <b>Up</b> and <b>Down</b> buttons to reorder the columns for the report.

**Note**

The filter-based reports have an additional field of **Location** that enables the user to retrieve reports on only the devices or events in the user's assigned location. (See [Figure 13-4](#)). This is based on the system configuration settings. For more about this, see [Logins page of the System Configuration window, page 17-11](#).

Figure 13-4 Filter based Report with Location

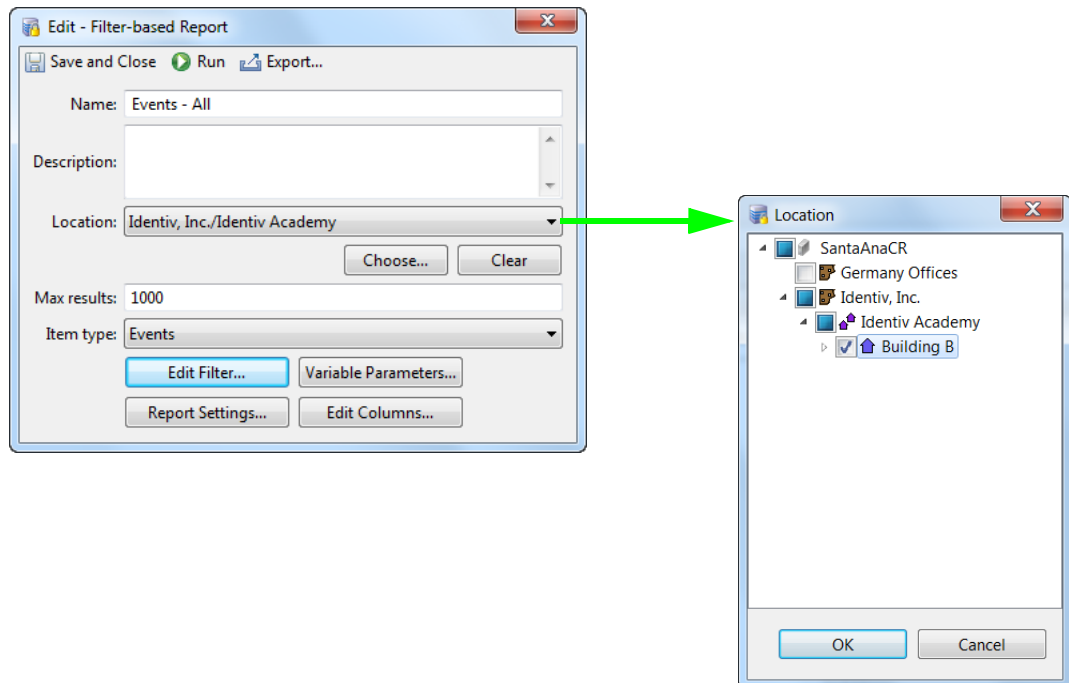

## Object SQL-based Report Template

When you add or edit a report, the **Report Manager** detail window includes properties for the specific type of report.

All report types include the following toolbar buttons:

- **Save and Close:** Save changes and close the report.
- **Run:** Run the report and open the contents of the report in a new window.
- **Export...:** Export the report to an XML file, which may be later imported on the same or another system.

Figure 13-5 shows the detail window for an Object SQL-based Report Template. Complete the fields according to the descriptions in Table 13-2.

Figure 13-5 Object SQL-based Report detail window

Table 13-2 Fields on the Object SQL-based Report detail window

Field	Description
<b>Name</b>	Enter a unique name for the report.
<b>Max results</b>	The number of results displayed in the report. The value -1 retrieves unlimited results.
<b>Item type</b>	The type of category to build the object SQL-based report on.
<b>SQL</b>	The SQL query to be executed. The SQL defined should only return a single column, which is the unique id of an object matching the <b>Item type</b> drop-down menu.

Table 13-2 Fields on the Object SQL-based Report detail window (continued)

Field	Description
<b>Report Settings...</b>	Report generation options. For more information on report settings see <a href="#">Creating Reports, page 3-10</a> ).
<b>Variable Parameters...</b>	Parameters the user is prompted to provide when running the report. Variable parameters replace question marks in the SQL query, in order. The number of parameters must match the number of question marks in the query.

## SQL-Based Report Template

When you add or edit a report, the **Report Manager** detail window includes properties for the specific type of report.

All report types include the following toolbar buttons:

- **Save and Close:** Save changes and close the report.
- **Run:** Run the report and open the contents of the report in a new window.
- **Export...:** Export the report to an XML file, which may be later imported on the same or another system.

Figure 13-6 shows the detail window for a SQL-based report template. Complete the fields according to the descriptions in Table 13-2.

Figure 13-6 SQL-based Report detail window

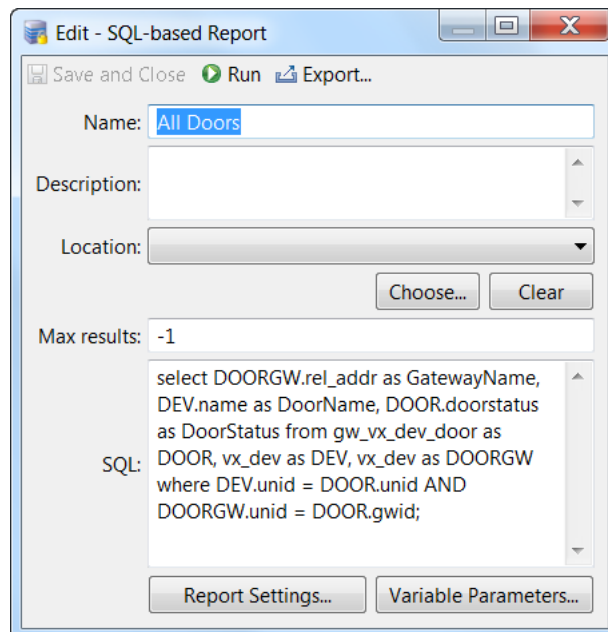

*Fields on the SQL-Based Report detail window*

Field	Description
<b>Name</b>	Enter a unique name for the report.
<b>Max results</b>	The number of results displayed in the report. The value -1 retrieves unlimited results.
<b>SQL</b>	The SQL query to be executed. It returns all the column data defined in the SQL.
<b>Report Settings...</b>	Report generation options. For more information on report settings see <a href="#">Creating Reports, page 3-10</a> .
<b>Variable Parameters...</b>	Dynamic parameters can be added through this option with a name and a type to match with any of the field columns defined in the SQL query. The previously added parameters could be viewed and edited. Parameters configured will prompt the user to provide values for them when the report is run and based on that data will be retrieved. The parameter values replace question marks in the SQL query, in order. The number of parameters must match the number of question marks in the query.  <b>Tip</b> A sample SQL based report template defined with variable parameters will have the sql query part like: "select evt_time from vx_evt where evt_time < (?) ;"

**Additional Information**

- To avoid non-Admin (other than Administrators profile) users from running and editing the SQL Based Reports to retrieve information beyond their access policies, unselect the 'Allow execution of SQL-based reports' option in **Users > Profiles > Add Profile/Edit Profile > Modules > Report Manager**.
- SQL-based reports can also be invoked from the Global I/O module through event or periodic trigger.
- Default sanity reports return unprivileged data.
- Contact the Support Team for any high-level ERD of database/assistance in writing complex SQL-based queries to meet individual requirements.



## System Integration

---

This chapter describes how to integrate the ICPAM data and actions with enterprise or third-party systems.

### Contents

- [Configuring URL Actions, page 14-2](#)
  - [Creating or Modifying URL Actions, page 14-3](#)
  - [Creating Automated Rules for URL Actions, page 14-5](#)
  - [Viewing URL Events, Alarms, and Logs, page 14-7](#)
- [Synchronizing Data Using Enterprise Data Integration \(EDI\), page 14-11](#)
  - [Before You Begin, page 14-11](#)
  - [Understanding Photo File Compression When Importing Personnel Records, page 14-12](#)
  - [Installing the EDI License and Desktop Application, page 14-13](#)
  - [Creating Active Directory Database Integration Projects Using EDI Studio, page 14-16](#)
  - [Creating SQL and Oracle Database Integration Projects Using EDI Studio, page 14-28](#)
  - [Importing, Starting, and Monitoring EDI Projects in ICPAM, page 14-40](#)
- [Accessing the SQL Database, page 14-49](#)



---

See also the *Cisco Physical Access Control API Reference Guide* and <http://www.identiv.com/support-icpam> for information on web services support.

---

## Configuring URL Actions

URL actions allow you to trigger actions in external systems when alarms or events occur in ICPAM. For example, URL actions can trigger the following in other systems:

- **Identiv Energywise:** a URL action can turn switch ports on or off, including any devices connected to those ports using Power-over-Ethernet (PoE). For example, when a user enters a building using a Identiv access control badge, the switch-powered equipment associated with that user can be turned on. When they exit the building, the equipment is turned off.
- **Camera integration:** a URL action can control the pan, tilt and zoom (PZT) functions of cameras associated with a device. For example, the camera can turn and zoom toward a door when badge is swiped at a door.
- **Digital media player (DMP) integration:** when a door event occurs, a URL action can display a custom HTML page on a DMP display.

To configure URL actions, select **URL Actions** from the **Admin** menu (Figure 14-1).

*Figure 14-1 URL Actions main window*

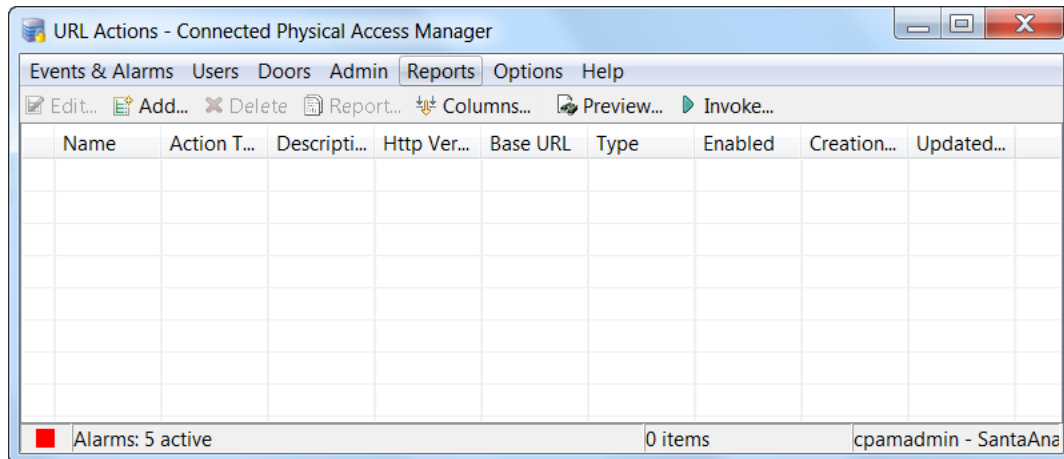

- Double-click an entry to view configuration settings.
- Click **Preview** to view the URL for an action.
- Select an entry and click **Invoke** to run a static action. (Dynamic actions cannot be manually invoked.)

See the following sections for instructions to create and automate URL actions:

- [Creating or Modifying URL Actions, page 14-3](#)
- [Creating Automated Rules for URL Actions, page 14-5](#)
- [Viewing URL Events, Alarms, and Logs, page 14-7](#)

# Creating or Modifying URL Actions

To add or modify URL actions, complete the following instructions:

**Step 1** Select **URL Actions** from the **Admin** menu.

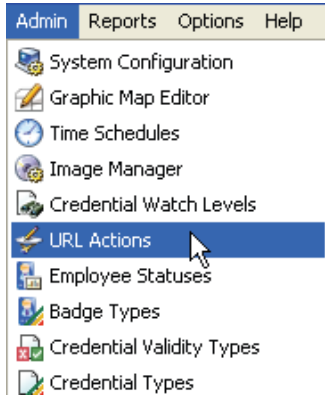

**Step 2** Click **Add** to create a new action, or select an existing action and click **Edit**.

**Step 3** In the resulting **Add URL Actions** or **Edit URL Actions** window, specify the basic properties.

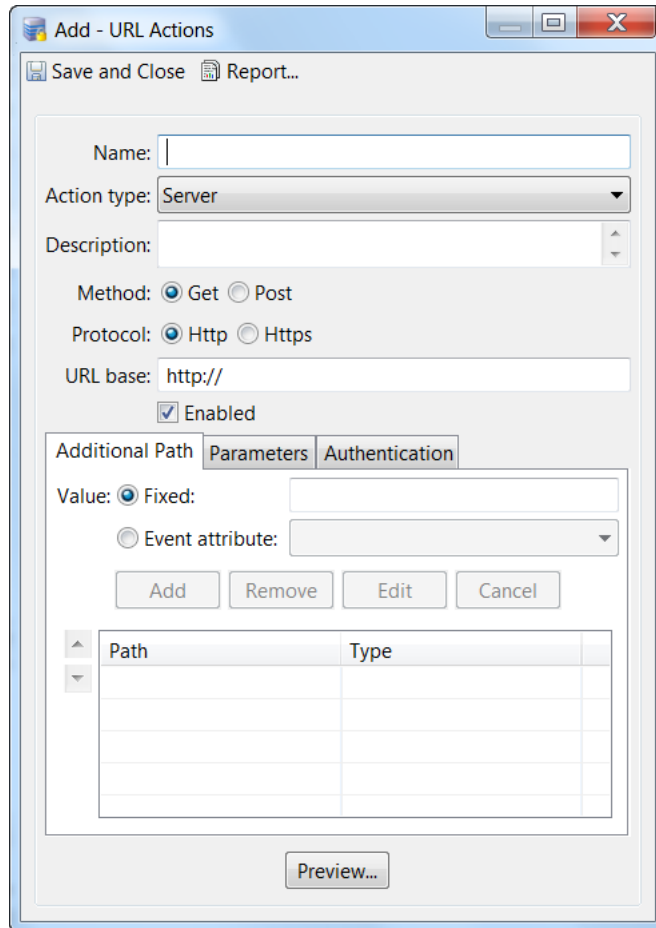

a. **Name:** type a unique descriptive name for this URL Action.

- b. **Action type:**
- c. **Description:** type a short description of this URL Action.
- d. **Method:** select the method (**Get** or **Post**) that the listening server will implement.
- e. **Protocol:** select the connection protocol (**Http** or **Https**) that will be used. The ICPAM default for secure connections is to present a client certificate, and accept all secure certificates.
- f. Type the **URL base**.  
This is the URL of the system that will be triggered. For example: `http://www.identiv.com`

#### Notes regarding the URL base

Enter the URL exactly as it appears in the browser after URL encoding. Special characters in URLs, such as spaces, are replaced with the HTML encoding of the corresponding ASCII character when entered in a Web browser. Enter the URL in a browser first, and then copy and paste the encoded URL in the **URL base** field.

For example, the URL `http://www.yahoo.com?thread=Wall Street` includes a space between Wall and Street. When entered in a web browser, the URL is converted to `http://www.yahoo.com?thread=Wall%20Street`. Copy and paste this converted URL into the **URL base** field.

- g. Select or deselect the **Enabled** check box to enable or disable this URL Action.

#### Step 4 (Optional) Enter any additional URL paths.

In the final URL, these values are separated from the base URL (and from each other) with a forward slash (/). The additional path value can be fixed text or an event attribute.

- a. Select the **Additional Path** tab.
- b. To enter a **Value**, select one of the following:
  - **Fixed:** enter the fixed text.
  - **Event attribute:** select an attribute from the drop-down menu.

Attributes include: Unique Event ID, Event Type/LogCode, Event Source, Device Type, Device Address, Location Site, Location Campus, Location Building, Location Floor, Location Area Name, Location Sub Area Name, Location Fully Qualified Name, Priority, Badge ID, User ID, Personnel ID, Person's Name (Last, First), Credential Watch Level, and Associated Camera ID.

- c. Click **Add**.  
The additional path appears in the list.
- d. Repeat these steps to create additional paths, if necessary.
- e. Click **Preview** to view the complete URL.



**Tip** Always preview the URL before saving the URL action. Any dynamic elements in the URL are displayed in brackets (<>), and will be replaced by the corresponding event used at run time.

For example, enter `sample_action` in the Fixed field. Click **Add** to add it to the list, and then click **Preview** to view the URL: `http://www.cosco.com/sample_action`.

Next, select the **Event attribute** button and select `Device Type` from the drop-down menu. Click **Preview** to view the new URL: `http://www.cosco.com/sample_action/<Device Type>`

**Step 5** (Optional) Enter the parameters used to construct the URL.

URL parameters consist of a name and a value, and are separated from the URL with a question mark (?).

- a. Select the **Parameters** tab.
- b. Enter a **Name** for the parameter. The name is always fixed.
- c. Select a **Value** option and enter one of the following. The value can be fixed or dynamic:
  - **Fixed**: enter the value text.
  - **Event attribute**: select an attribute from the drop-down menu. The parameter is captured from the specified event.  
Attributes include: Unique Event ID, Event Type/LogCode, Event Source, Device Type, Device Address, Location Site, Location Campus, Location Building, Location Floor, Location Area Name, Location Sub Area Name, Location Fully Qualified Name, Priority, Badge ID, User ID, Personnel ID, Person's Name (Last, First), Credential Watch Level, and Associated Camera ID.
  - **Complete event**: Available for *Post* actions only. The entire event information is included as an xml segment in the data posted to the URL
- d. Click **Add**. The parameter appears in the list.
- e. Create additional parameters, if necessary. Parameters are separated in the URL with an ampersand (&).
- f. Click **Preview** to view the complete URL.

In the following example, the Parameter entries are shown after the question mark, and are separated by an ampersand (&). *http://www.identiv.com/sample\_value/*

```
<Device Type>?Fixed_Text=text_sample&Event_Attr=<Device Address>
```

**Step 6** (Optional) Enter the username and password required to access the URL.



**Note** The username and password is used for servers requiring authentication. If authentication is unsuccessful, the server returns the response code of **401: Unauthorized**. This code is placed in the data field of the event generated from executing the URL action.

**Step 7** When you are finished, click **Save and Close**.

## Creating Automated Rules for URL Actions

Complete the following instructions to create a rule that automatically invokes a URL action based on a schedule or access control event. You can also create a rule that is manually triggered using a Quick Launch button or other method.

**Step 1** Select **Global I/O** from the **Events & Alarms** menu.

**Step 2** Click **Add**.

**Step 3** In the resulting window, type a **Name** for the rule, and select or deselect the **Enabled** check box.

**Step 4** Enter a trigger type for the rule.

Click **New** or **Edit** to define the Trigger Type. The choices are:

- **Event:** The rule is invoked when an event occurs. Select **Event** then click **Edit Filter** to select the event log code.
- **Periodic** (time schedule): The rule is invoked according to a **Monthly**, **Weekly**, or **Daily** schedule. Select the day of week or day of month, if necessary, and the **Time of day** (in a 24-hour format).
- **Manual Only:** The rule is invoked manually. Create a Quick Launch button for the rule, or right-click the Automation Driver to select the rule.

**Step 5** Select a URL Action:

- a. Click **Add** to add an action.
- b. Select the Action type of **URL Action**.
- c. Select a URL Action from the drop-down list.
- d. (Optional) Click **New** or **Edit** to create or modify a URL action. Click **Preview** to view the URL for the action. See [Configuring URL Actions, page 14-2](#) for more information.
- e. Click **Save and Close**.

**Step 6** Specify a **Notification** option to define where the notification or report file is sent. The options are:

- **E-mail:** Sends the notification or report file to one or more e-mail addresses. To enable e-mail notifications, you must enter the SMTP server settings in the Automation driver. For instructions, see the [“Enabling the Automation Driver”](#) section on page 13-18.
- **FTP:** Sends the file to the specified FTP server.
  - **Host:** The FTP server IP address or name.
  - **Username:** Log in username required by the FTP server.
  - **Password:** Password to log in to the FTP server.
  - **Path:** Path on the FTP server where files should be uploaded.
- **Syslog:** Sends the notification or report to a syslog.
  - **Host:** The Syslog server IP address or name.
  - **Facility:** The facility to use when recording the information to the syslog.

**Step 7** Select the event recording options.

Click the check boxes to activate or deactivate the options:

- **Record event when rule invoked:** Each time the rule is invoked, record an event.
- **Record event when trigger fails:** Each time the trigger fails, record an event.
- **Record event when action fails:** Each time the action fails, record an event
- **Record event when notification fails:** Each time the notification fails, record an event.

**Step 8** Click **Save and Close**.

---

## Viewing URL Events, Alarms, and Logs

An event is recorded each time a URL action is created or invoked. If a URL action fails, an alarm is recorded.

The URL Log in the ICPAM Server Administration utility also displays the output (HTTP response) from URL actions.

Examples of URL events, alarms, and log entries are shown in the following sections:

- [Viewing URL Action Events, page 14-7](#)
- [Viewing Alarms for Failed URL Actions, page 14-8](#)
- [Event and Alarm Response Codes for URL Actions, page 14-8](#)
- [Viewing Logs for URL Action Output, page 14-9](#)
- [URL Action Failure Due to Invalid Security Certificate, page 14-10](#)

### Viewing URL Action Events

To view events:

1. Select **Events** from the **Events & Alarms** menu, under the **Monitoring** submenu.
2. Click the column titles to sort events by description, time, or other properties.
3. Double-click the entry to view alarm details, or right-click an entry to select a command.

See [Viewing Events, page 12-3](#) for more information.

*Figure 14-2 URL Action Events*

Time	Description	Device	Address	F	Data
3/12/2009 14:34:40.000	URL: URL action execution Succeeded	Access GW Driver	localhost		Record type : URLAction: URL_POST_Cc
3/12/2009 14:34:39.000	URL: URL action execution Succeeded	Access GW Driver	localhost		Record type : URLAction: URL_POST_Cc
3/12/2009 14:34:34.000	URL: URL action execution Succeeded	Access GW Driver	localhost		Record type : URLAction: URL_GET_PAM
3/12/2009 14:34:27.000	URL: URL action execution Succeeded	Access GW Driver	localhost		Record type : URLAction: URL_GET_PAM
3/12/2009 14:34:25.000	URL: URL action execution Succeeded	Access GW Driver	localhost		Record type : URLAction: URL_POST_Cc
3/12/2009 14:34:24.000	URL: URL action execution Succeeded	Access GW Driver	localhost		Record type : URLAction: URL_POST_Cc
3/12/2009 14:34:23.000	URL: URL action execution Succeeded	Access GW Driver	localhost		Record type : URLAction: URL_POST_Cc
3/12/2009 14:34:22.000	URL: URL action execution Succeeded	Access GW Driver	localhost		Record type : URLAction: URL_POST_Cc
3/13/2009 09:57:52.000	URL: URL action execution Failed	Access GW Driver	localhost		Record type : sun.security.validator.Val
3/13/2009 00:21:19.000	URL: URL action execution Failed	Access GW Driver	localhost		Record type : Could not connect to the I
3/13/2009 00:13:10.000	URL: URL action execution Failed	Access GW Driver	localhost		Record type : sun.security.validator.Val
3/13/2009 00:02:55.000	URL: URL action execution Failed	Access GW Driver	localhost		Record type : sun.security.validator.Val
3/13/2009 00:02:54.000	URL: URL action execution Failed	Access GW Driver	localhost		Record type : sun.security.validator.Val
3/13/2009 00:02:39.000	URL: URL action execution Failed	Access GW Driver	localhost		Record type : sun.security.validator.Val
3/12/2009 23:57:52.000	URL: URL action execution Failed	Access GW Driver	localhost		Record type : sun.security.validator.Val
3/12/2009 23:49:39.000	URL: URL action execution Failed	Access GW Driver	localhost		Record type : sun.security.validator.Val
3/12/2009 23:46:37.000	URL: URL action execution Failed	Access GW Driver	localhost		Record type : sun.security.validator.Val
3/12/2009 23:42:19.000	URL: URL action execution Failed	Access GW Driver	localhost		Record type : sun.security.validator.Val

Alarms: 10 active | 500 items | cpamadmin - SJC

## Viewing Alarms for Failed URL Actions

To view only failed URL actions:

1. Select **Alarms** from the **Events & Alarms** menu, under the **Monitoring** submenu.
2. Use the **Ack**, **Comment**, and **Clear** buttons in the toolbar to clear the alarm or add comments.
3. Double-click the entry to view alarm details, or right-click an entry and select a command.

See [Viewing Alarms, page 12-8](#) for more information.

**Figure 14-3** URL Action Alarms

The screenshot shows a software window titled "Alarms - Connected Physical Access Manager". The window has a menu bar with "Events & Alarms", "Users", "Doors", "Admin", "Reports", "Options", and "Help". Below the menu bar is a toolbar with icons for "View...", "Report...", "Columns...", "Ack", "Comment", "Clear", "Ack All", "Comment All", and "Clear All". The main area contains a table with the following columns: "Alarm State", "Count", "Time", "Description", "Device", and "Address". The table lists several active alarms, including "URL: URL action execution Failed" and "Door Forced Open".

Alarm State	Count	Time	Description	Device	Address
Active	1	3/13/2009 09:57:52.000	URL: URL action execution Failed	Access GW Driver	localhost
Active	1	3/13/2009 00:21:19.000	URL: URL action execution Failed	Access GW Driver	localhost
Active	2	3/13/2009 00:13:10.000	URL: URL action execution Failed	Access GW Driver	localhost
Active	2	3/13/2009 00:02:54.000	URL: URL action execution Failed	Access GW Driver	localhost
Active	6	3/13/2009 00:02:39.000	URL: URL action execution Failed	Access GW Driver	localhost
Active	1	3/12/2009 23:33:40.000	URL: URL action execution Failed	Access GW Driver	localhost
Active	4	3/12/2009 13:08:58.000	URL: URL action execution Failed	Access GW Driver	localhost
Active	16	3/13/2009 11:01:28.000	Door Forced Open	Door2E_m3	/SJC/gw_
Active	6	3/12/2009 13:53:16.000	Door Deny Access Use Limit Expired	DoorCP_m0	/SJC/gw_
Active	11	3/12/2009 13:17:37.000	Door Deny Access	DoorCP_m0	/SJC/gw_

At the bottom of the window, a status bar shows "Alarms: 10 active", "10 items", and "cpamadmin - SJC".

## Event and Alarm Response Codes for URL Actions

The response code from the server is included in the data field. The response codes include the following:

### Event Response Codes

- HTTP Status Code 200:OK
- HTTP Status Code 203:Non Authoritative
- HTTP Status Code 204:No Content
- HTTP Status Code 301:Moved Permanently
- HTTP Status Code 302 or 307:Temporary Redirect

### Alarm Response Codes

- HTTP Status Code 400:Bad Request
- HTTP Status Code 401:Unauthorized
- HTTP Status Code 403:Forbidden
- HTTP Status Code 404:Not Found
- HTTP Status Code 405:Method Not Allowed
- HTTP Status Code 406:Not Acceptable
- HTTP Status Code HTTP Status Code 414:Request-URI Too Large



- HTTP Status Code 500:Internal Server Error
- HTTP Status Code 501:Not Implemented
- HTTP Status Code 503:Service Unavailable
- HTTP Status Code 505:HTTP Version Not Supported

## Viewing Logs for URL Action Output

To display the output (HTTP response) from URL actions, open the URL Log in the ICPAM Server Administration utility.

**Step 1** Log on to the ICPAM appliance, as described in [Logging on to the ICPAM Server Administration Utility, page 2-2](#).

**Step 2** Select the **Monitoring** tab, and then select **URL Log**.

Figure 14-4 shows the menu and sample log.

**Figure 14-4** URL Action Log

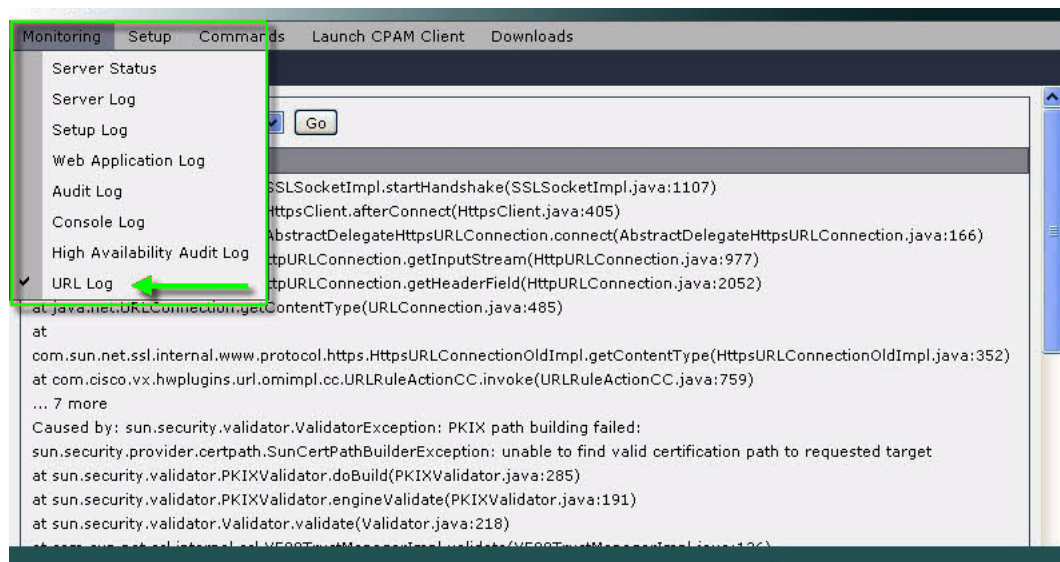

## URL Action Failure Due to Invalid Security Certificate

If a URL Action fails due to an invalid security certificate, the following log entry is displayed in the ICPAM Server Administration utility (see [Viewing Logs for URL Action Output, page 14-9](#)):

```
sun.security.validator.ValidatorException: PKIX path building failed:  
sun.security.provider.certpath.SunCertPathBuilderException: unable to find valid  
certification path to requested target.
```

To resolve this issue, do one of the following:

- When the URL Action was invoked by clicking the **Invoke** button in the URL Action window, restart the ICPAM client and try again.
- When the URL Action was invoked by an automated rule, stop and start the ICPAM server, and try again. See [Using the Web Admin Menus, Commands, and Options, page 2-19](#) for instructions to restart the server.
- When the URL Action was invoked by a Quick Launch button, stop and start the ICPAM server, and try again. See [Using the Web Admin Menus, Commands, and Options, page 2-19](#) for instructions to restart the server.

# Synchronizing Data Using Enterprise Data Integration (EDI)

EDI is used to synchronize data from Active Directory, Microsoft SQL Server, MySQL, and Oracle database to the ICPAM database. This section includes instructions to do the following:

- Install the **EDI license** on the ICPAM server.
- Download and install the **EDI Studio** desktop application on your PC.
- Use the **EDI Studio** to define integration projects, including the database connection, schema, and synchronization schedule.
- Import the data integration project file into ICPAM using the **EDI Administration** module.
- Monitor and troubleshoot data integration events using the **EDI Monitoring** and **Error Monitoring** modules.

Complete the following instructions to create, run, and monitor EDI integration projects:

- [Before You Begin, page 14-11](#)
- [Understanding Photo File Compression When Importing Personnel Records, page 14-12](#)
- [Installing the EDI License and Desktop Application, page 14-13](#)
- [Creating Active Directory Database Integration Projects Using EDI Studio, page 14-16](#)
- [Creating SQL and Oracle Database Integration Projects Using EDI Studio, page 14-28](#)
- [Importing, Starting, and Monitoring EDI Projects in ICPAM, page 14-40](#)
  - [Importing and Starting EDI Projects, page 14-40](#)
  - [Verifying EDI Projects \(EDI Monitoring\), page 14-42](#)
  - [Modifying a Running EDI Project, page 14-45](#)
  - [Restarting a Failed EDI Project, page 14-47](#)
  - [Summary of EDI Administration Functions, page 14-47](#)

## Before You Begin

Review the following notes before creating EDI projects:

- This optional feature requires an Identiv license. The **EDI** menu appears only after the license is installed on the ICPAM server. See [Obtaining and Installing Optional Feature Licenses, page 2-45](#) for instructions.
- The source database records are the master version: imported records cannot be deleted in ICPAM. Test a few personnel records in a staging environment before implementing EDI projects.
- Importing a large number of personnel records can cause system delays. To avoid system interruption, perform the initial import during off-peak hours, and stop the Gateway Driver to enable the process to complete. To stop the driver, select **Hardware - Tree** from the **Doors** menu, right-click on the **Access GW Driver**, and select **Disable**. When the import is complete, select **Enable**. This process is only necessary when importing thousands of records, such as during the initial import of all database records.
- Personnel records are unique, based on the ID number of the record. If a record is imported with the same ID number, then the current record is overwritten with the new data.

- EDI Active Directory (AD) projects run immediately when the camera driver is restarted, or when ICPAM is synchronized with the Video Surveillance Manager (VSM). The projects' scheduled run time are also reset.

For example, if an AD project is scheduled to run at 5 pm daily, and the camera driver is restarted at 10 am, the EDI project will run and the schedule will be reset to 10 am. To avoid this, stop the EDI project before restarting the camera driver or synchronizing the Identiv VSM server. Restart the EDI project after the actions are complete. For more information, see [Summary of EDI Administration Functions, page 14-47](#) and [Managing the Camera Inventory, page 15-27](#).

- Stop any running EDI projects before upgrading the ICPAM appliance software. After the upgrade, you can restart the projects. See [Importing and Starting EDI Projects, page 14-40](#) for instructions to stop, start, and import EDI projects. If EDI projects are not stopped before a ICPAM upgrade, the project execution (or run) will not be successful. If this occurs, contact your Identiv support representative for assistance.



---

**Note** If upgrading from CPAM Release 1.0 or Release 1.1, you must also recreate the EDI projects using the EDI Studio application.

---

- Only personnel photos in the .JPEG or .JPG format are supported for import. In addition, the photos must be in RGB format. Other image formats are ignored when importing personnel data.
- For importing EDI personnel data from Active Directory, users should not make major modifications to the AD schema and the User object should contain the field name **when changed**.

## Understanding Photo File Compression When Importing Personnel Records

Photo files that are imported into the ICPAM personnel database can be a maximum of 750 KB per image. If a photo is larger than the defined maximum, the file is automatically compressed by ICPAM.

You can change the maximum file size for imported photo files using the System Configuration module. For example, if you enter a maximum file size of 500 KB, then any files larger than 500 KB will be automatically compressed when the personnel record is imported.



---

**Note** Only personnel photos in the .jpg format are supported for import.

---

To set the maximum file size limit, do the following:

- 
- Step 1** Select **System Configuration** from the **Admin** menu.
  - Step 2** Select **Cisco Settings** on the left ([Figure 14-5](#)).
  - Step 3** In the field *EDI personnel's photo size limit*, enter the maximum file size for the imported file.
    - Enter a value, in KB, between 50 and 750.
    - The default value is 250 KB.





---

**Note** Any photo file larger than the specified size will be automatically compressed during the EDI import operation. A small loss of image quality may be noticeable in the compressed image.

---

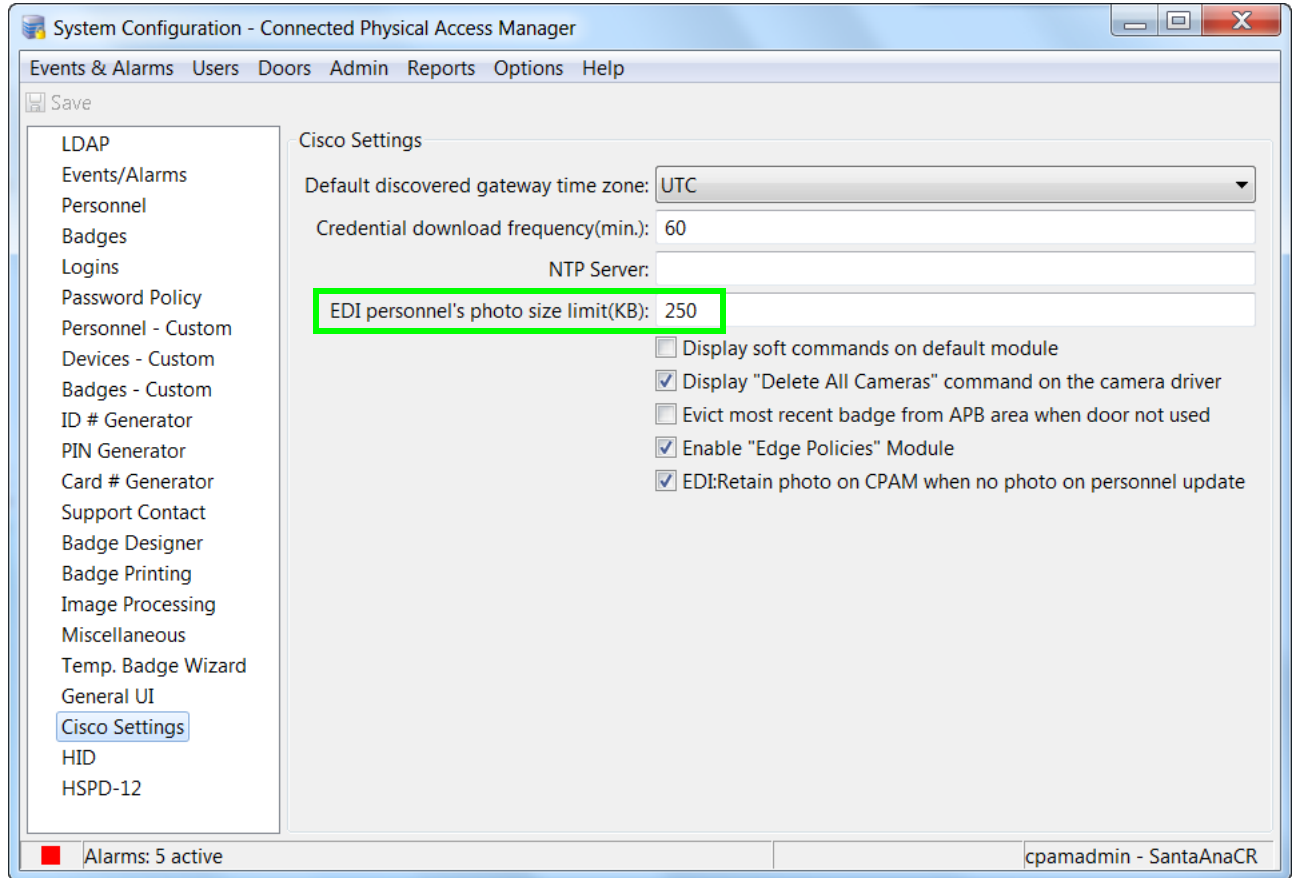
Figure 14-5 ICPAM Settings



**Step 4** Click **Save** to save the changes.

**Step 5** Log out (select **Logout** from the **Options** menu) and log back into the ICPAM application, to activate the changes.

## Installing the EDI License and Desktop Application

To enable EDI database integration, complete the following tasks:

1. Install the EDI license on the ICPAM server.
2. Start the EDI driver in the ICPAM hardware module.
3. Install the EDI Studio desktop software on your PC.

**Step 1** Install the EDI license on the ICPAM server. [Figure 14-6](#) shows the EDI license installed on an ICPAM server. See [Using the Web Admin Menus, Commands, and Options, page 2-19](#) for information to view the installed licenses, or purchase and install new licenses.

Figure 14-6 ICPAM Licenses

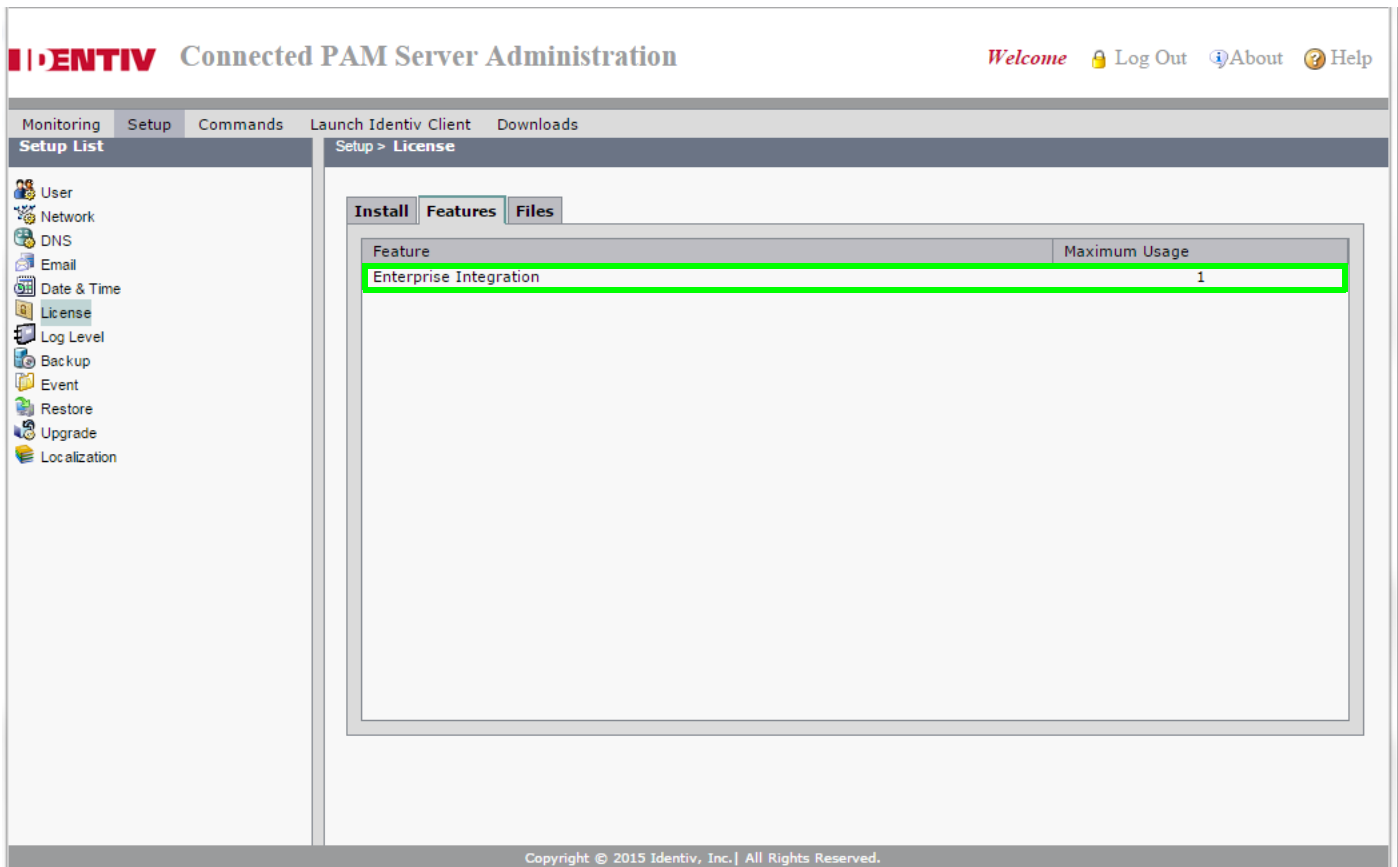

- Step 2** If necessary, create and start the EDI driver.
- Select **Hardware - Tree** from the **Doors** menu.
  - If the EDI Driver is already included in the driver list, go to [Step 3](#).
  - If the EDI driver is not included, right-click the **Driver Manager** and select **New EDI Driver**.
  - Right-click the EDI Driver and select **Start**. The driver status should be **Started** (as highlighted in [Figure 14-7](#)).

Figure 14-7 EDI Driver

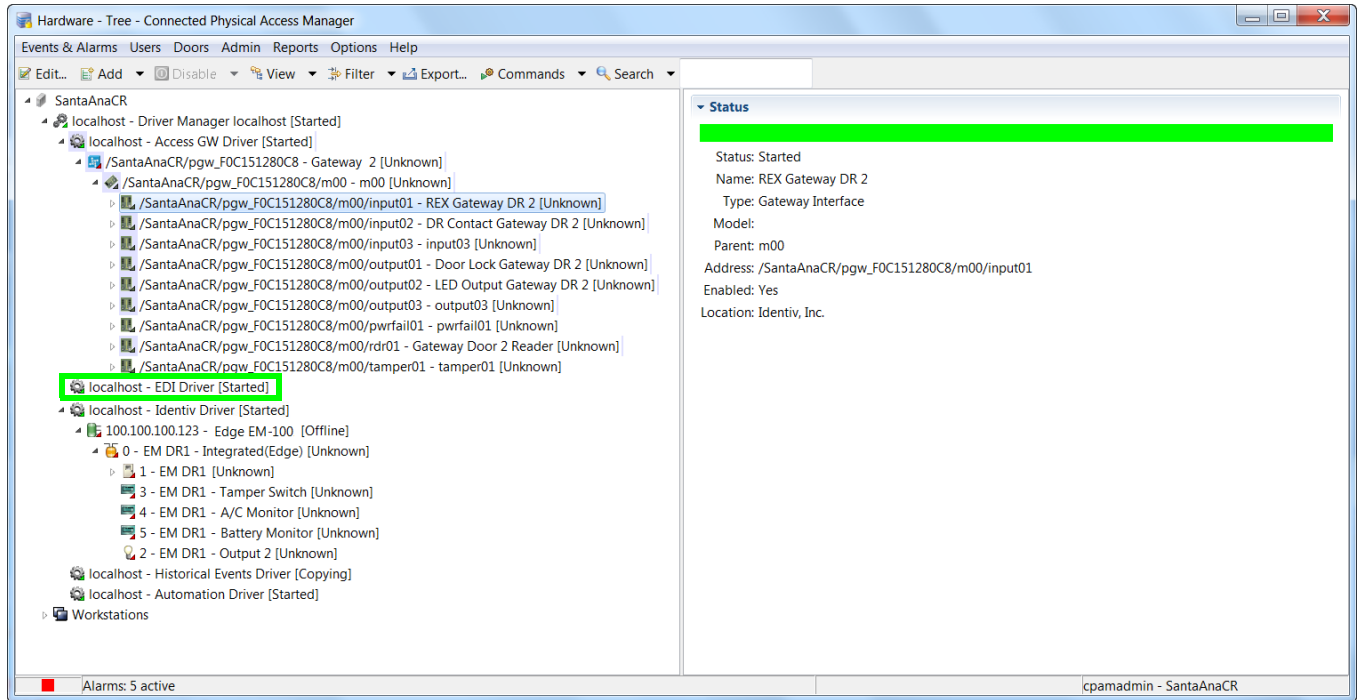

**Step 3** Download and install the EDI Studio desktop software.

- a. Open a Web browser and enter the IP address for the ICPAM Server Administration utility.
- b. Click **Download Identiv EDI Studio** on the Login page, as shown in Figure 14-8. You do not need to log on to the utility to download the software. If necessary, the required version of Java is also installed.

Figure 14-8 Download EDI Studio



**Tip**

You can also log into the ICPAM Server Administration utility and select **Download Identiv EDI Studio (JRE Required)** from the **Downloads** menu. See [Using the Web Admin Menus, Commands, and Options, page 2-19](#).

- c. Save the installation file to your local drive.
- d. Double-click the EDI Studio installer file on your local drive to download and launch the installer.
- e. Follow the on-screen prompts to install the EDI Studio desktop application. The application opens automatically when the installation is complete.
- f. Select **EDI Studio** from the shortcut on your desktop or from your Windows Programs menu.

## Creating Active Directory Database Integration Projects Using EDI Studio

The EDI desktop application is used to define data integration projects. After it has been created, the project is imported into ICPAM to begin data synchronization.

This section provides an example to import personnel records from a Microsoft Active Directory database into the ICPAM database. This example does not cover every possible scenario, and the specific records, fields, and other data may not match the details for your site. Contact your Active Directory administrator for assistance when performing this process.

Review the following notes before creating and running an Active Directory project:

- ICPAM supports a single Active Directory project in EDI. You can create multiple Active Directory projects, but only one can run.
- The EDI feature is tested and certified for Active Directory Server 2003.
- A user ID and password is required to access user objects from Active Directory schema.
- EDI only supports photos in the JPEG format. For more information, see [Understanding Photo File Compression When Importing Personnel Records, page 14-12](#).
- Users should not make major modifications to the Active Directory schema.
  - The User Object supports timestamp by default.
  - If *changed timestamp* is disabled in Active Directory, EDI project can not run.





- Step 4** On the **Choose Project Template** page of the **New Project** wizard, name the project and specify the project properties:

The screenshot shows a dialog box titled "New Project" with a sub-header "Choose Project Template". It contains the following fields and options:

- Project name: AD\_Project
- Project template: Personnel Data Import From Microsoft Active Directory
- Source DB: Active Directory
- Destination DB: MySQL

At the bottom of the dialog, there are four buttons: "< Back", "Next >", "Finish", and "Cancel".

- Project name:** enter the name of the project.
- Project template:** select a template for Microsoft Active Directory.
- Source DB:** select the source database.
- Destination DB:** select the destination database.
- Click **Next**.

- Step 5** On the **Active Directory Source Parameters** page of the **New Project** wizard, specify the Active Directory database parameters:

- a. **Host IP**: enter the IP address of the database server.



**Note** The Active Directory Host IP address must be accessible from the ICPAM appliance network. For example, both systems should be on the same network.

- b. **Port**: enter the TCP port for the database server. Port 389 is the default for LDAP.

- c. **Search base**: the Distinguished Name (DN) to use as a base for queries. For example: `dc=foobar`.



**Note** ICPAM is configured to send the `cn=` parameter, which must exactly match the `cn` parameter in Active Directory for the account.

- d. **Login Name (Full DN)**: the username required to log in to the database.

- e. **Password**: the database password.



**Note** The values for **Search base**, **Login name**, and **Password** should be provided by your Active Directory administrator.

- Step 6** Click **Next** or **Test Connection** to validate the server settings.

- If the settings are valid, a dialog stating **Test connection successful** appears.

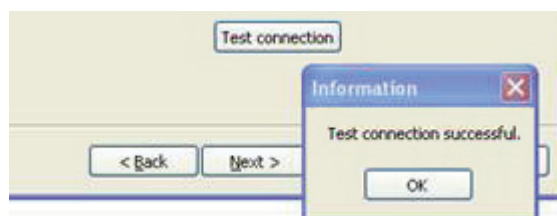

- If the settings are not valid, an error dialog stating **Test connection failed** appears. One or more of the parameters is incorrect. Work with your Active Directory administrator to obtain the correct settings, then test the connection again.

**Tip**

To verify the Active Directory user account attribute for the ICPAM login, use the tools described in the following step. ICPAM is configured to send the `cn=` parameter, which must exactly match the `cn` parameter in Active Directory for the account.

**Step 7** Map the equivalent fields between the *Destination* ICPAM database and the *Source AD attributes*.

- a. Enter the field name, or select an option from the drop-down menu.
  - Required destination fields are marked with an asterisk (\*). The other fields are optional.
  - You must enter values for the **site** and **govt\_id\_spec**, either in this window, or in the following database properties window. If you enter values in the current window, the individual record data is used (and the default value is ignored). To use default values, leave the fields blank in this window, and enter them in the following window (Default/Transform Values).
  - **Map emp\_status** to the appropriate AD attribute. For example, *active* or *inactive*. Consult your Active Directory administrator for more information about this attribute.

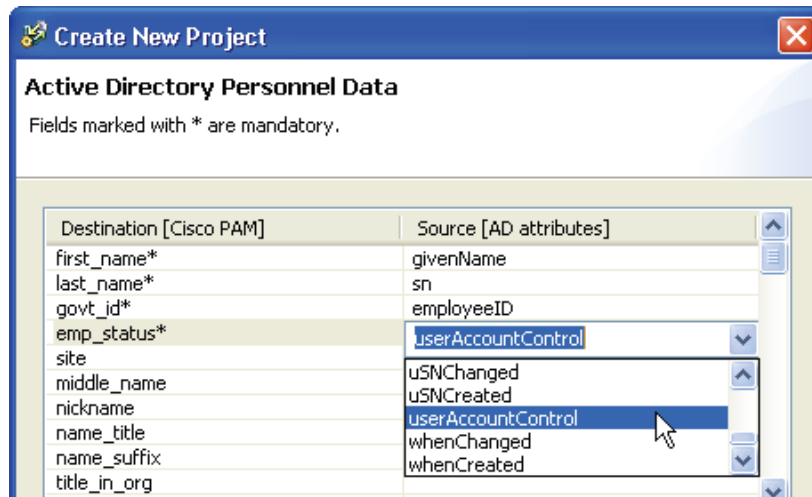

- See also [Notes for Mapping the AD and ICPAM User Attribute Names](#), page 14-21.
- b. Click **Next** to verify the settings and continue to the next configuration screen.  
Clicking **Next** verifies the settings.

If the test is not successful, verify that the prefix `cn=` is used for the login name in the Active Directory Source Parameters window, as described in Step 5d. of this procedure.

### Notes for Mapping the AD and ICPAM User Attribute Names

In the AD structure, a user's name includes an attribute `sn` for the last name, and another attribute `givenName` for the first name. For example, Mike Smith would include:

- `sn=Smith`
- `givenName=Mike`

When you create an AD user login for the ICPAM server, you must also configure a first and last name, or the database mapping will fail.

Two tools can help you determine the Active Directory attribute name that corresponds to an ICPAM record. The first is called **LDAP Browser\Editor**. Although Identiv does not provide this tool and does not document its usage, the sample output in its right pane shows the information you need to obtain for use with the EDI project.

In this example, the `cpam` user allows the ICPAM server to log in to the AD database. The `sn` attribute defines the last name, and the `givenName` attribute defines the first name. In addition, the Active Directory attribute `department` is defined. This attribute is mapped to the ICPAM field `govt_id`.

Attribute	Value
accountExpires	9223372036854775807
adminCount	1
badPasswordTime	0
badPwdCount	0
cn	cpam
codePage	0
countryCode	0
department	24681357
displayName	cpam
distinguishedName	CN=cpam,CN=Users,DC=dms,DC=cisco,DC=com
givenName	Mike
initials	A
instanceType	4
lastLogoff	0
lastLogon	128927727166461250
logonCount	3
memberOf	CN=Administrators,CN=Builtin,DC=dms,DC=cisco,DC=com
name	cpam
objectCategory	CN=Person,CN=Schema,CN=Configuration,DC=dms,DC=cisco,DC=com
objectClass	top
objectClass	organizationalPerson
objectClass	user
objectClass	person
objectGUID	0c0f0ned01e0000y
objectSid	0000000000008%Pitui0z,0j000
primaryGroupID	513
pwdLastSet	128919871203023750
sAMAccountName	cpam

You can also extract user data to a CSV (comma separated values) file to view the Active Directory attributes. For example, the following command generates a CSV file with user data.

```
CSVDE -f onlyusers.csv -r "(&(objectClass=user)(objectCategory=person))"
```

That command runs the CSVDE (comma separated values data export) tool and creates a file named `onlyusers.csv`. Filters are used to limit the output to users and persons.



**Tip** Your system administrator may have additional knowledge of the CSVDE tool and output limiting filters.

Open the `onlyusers.csv` file in Excel to view the Active Directory attributes and the fields they map to, as shown in this next screen capture. The green highlighting shows how the fields correspond to the ICPAM personnel records fields.

	AJ	AK	AL	AM	AN
1	sn	givenName	initials	userPrincipalName	department
2					
16	Brown	Mikey	Active	mbrown@dms.cisco.com	1234567
17	Name	Fisrt	I	fname@dms.cisco.com	12345678
18	User	New	B	newuser@dms.cisco.com	

The ICPAM Active Directory Personnel Data window is shown with the correct field mappings. Click **Next** to validate the attribute mappings.

**Step 8** Define the Active Directory default database values.

For example, enter the following in the **Source Attribute Value** column:

CPAM Attribute Value	Source Attribute Value
site	SanJose
govt_id_spec	ID#
emp_status (active)	Active(A)
emp_status (inactive)	I
emp_status (on leave)	O
emp_status (retired)	R
emp_status (terminated)	Terminated

- Enter a **site**. The **site** must match the ICPAM site name. The site name is shown in the bottom right corner of all ICPAM client windows. The site name is also displayed at the top of the Hardware tree.
- Enter the **govt\_id\_spec** value.

**Note** The entries are ignored if values are also entered in the previous **Personnel Data** window. You must enter values for these fields in only one of the windows.

- c. Enter the AD attribute used by your organization for each of the **emp\_status** fields. For example, enter **I** for **emp\_status (inactive)** or **R** for **emp\_status (retired)** employees. ICPAM supports employee status values of active, inactive, on leave, retired, and terminated.

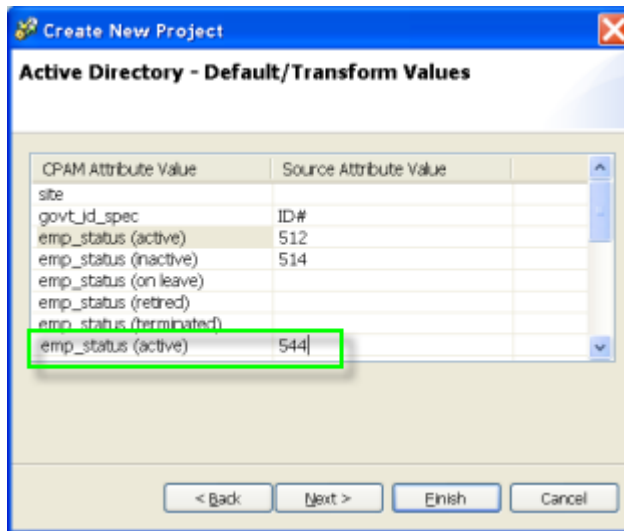
**Tip**

If your organization has additional employee status codes, such as 544 to indicate that a user is active but their password has expired, you can manually add those codes to the bottom of the list (as shown above). In the *ICPAM Attribute Value* column, manually enter an existing ICPAM value, such as **emp\_status (active)**. In the *Source Attribute Value* column, enter your organization's code. You can also create new employee status attributes, if necessary. See [Creating Custom Employee Status Values, page 14-26](#).

- d. Click **Next** to continue.

**Step 9** (Optional) If necessary, select an EDI Extension file.

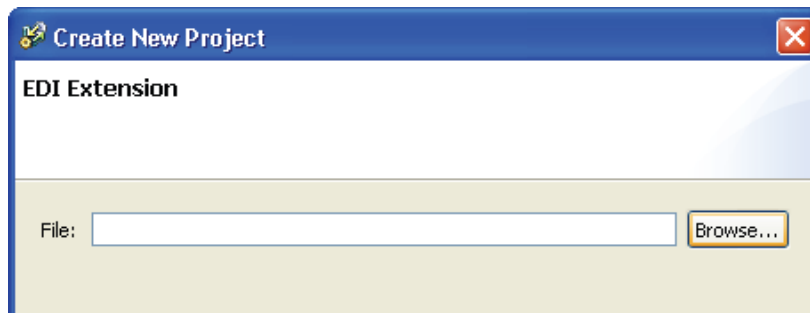

EDI Extension files use API classes to extend the basic EDI functionality, such as the following:

- Transform badge and personnel data received from an AD database. For example, remove the leading **1** from the Badge ID.
- Define the default mapping. For example, assign Badge Templates based on the badge type.
- Provide cross field validation (such as dependency fields, or correlation across different attributes or between badge and personnel data).

An EDI Extension is a Java program that plugs into the EDI Project, and enables you to modify the incoming data before it is included in ICPAM. This custom programming can be done by Identiv's Professional Services Group; contact them to discuss the specific requirements for your project and obtain a quote for the work.

**Procedure:**

- a. Click **Browse**.
- b. Select the extension file that will be called when writing data into the personnel and badge interface tables. The extension file is validated by the EDI Studio.
- c. Click **Next** to continue.

**Step 10** Choose a schedule to specify how often data will be synchronized.

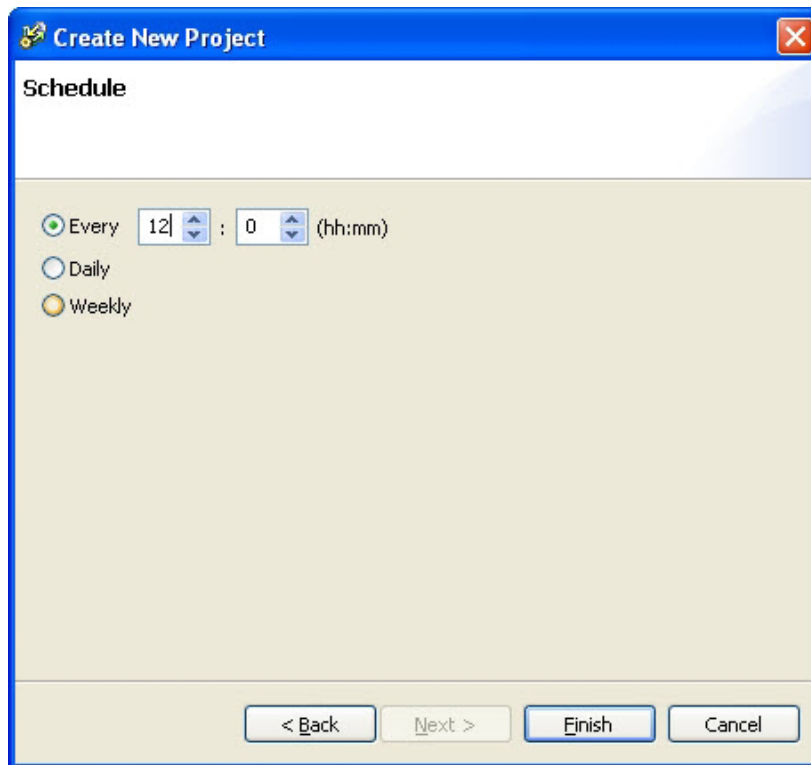

- **Every hh:mm**: the data synchronization begins once every hour/minute specified.
- **Daily**: the data synchronization is conducted once a day.
- **Weekly**: the data synchronization is conducted once a week.

**Scheduling Notes:**

- Schedules are based on the ICPAM appliance time and time zone settings (not the AD source database server settings).
- The default project schedule is 60 minutes. This setting is configurable.
- The EDI (Core) frequency is two minutes. This setting is read-only.
- ICPAM retrieves records with a 15 minute overlap from the previous run to prevent loss of data; all records will be included even if the ICPAM and Active Directory server time settings are a few minutes apart.





## Creating Custom Employee Status Values

The employee status (`emp_status`) attribute defines if a user is active or inactive. The fields supported by default are:

- `emp_status (active)`—the user account is *active*.
- `emp_status (inactive)`—the user account is *inactive*.
- `emp_status (on leave)`—the user account is *inactive*.
- `emp_status (retired)`—the user account is *inactive*.
- `emp_status (terminated)`—the user account is *inactive*.

If necessary, you can create additional employee status values. Each identifies the user account as either active or inactive. For example, an organization uses the value of 512 for Active and 514 for Inactive, but they also use an additional value of 544 for an active user with an expired password. You can create this new active user status in ICPAM, and then enter the definition in EDI.

- Step 1** Enable the *Employee Statuses* module (which is disabled by default).
- Select **Profiles** from the **Users** menu.
  - Double-click the user profile for the user who administers EDI projects.  
For example, select **Administrators**.  
You can also select the profile name and click **Edit**.
  - In the *Edit - Profile* window, select the **Modules** tab (Figure 14-9).

Figure 14-9 Modules Available to a User Profile

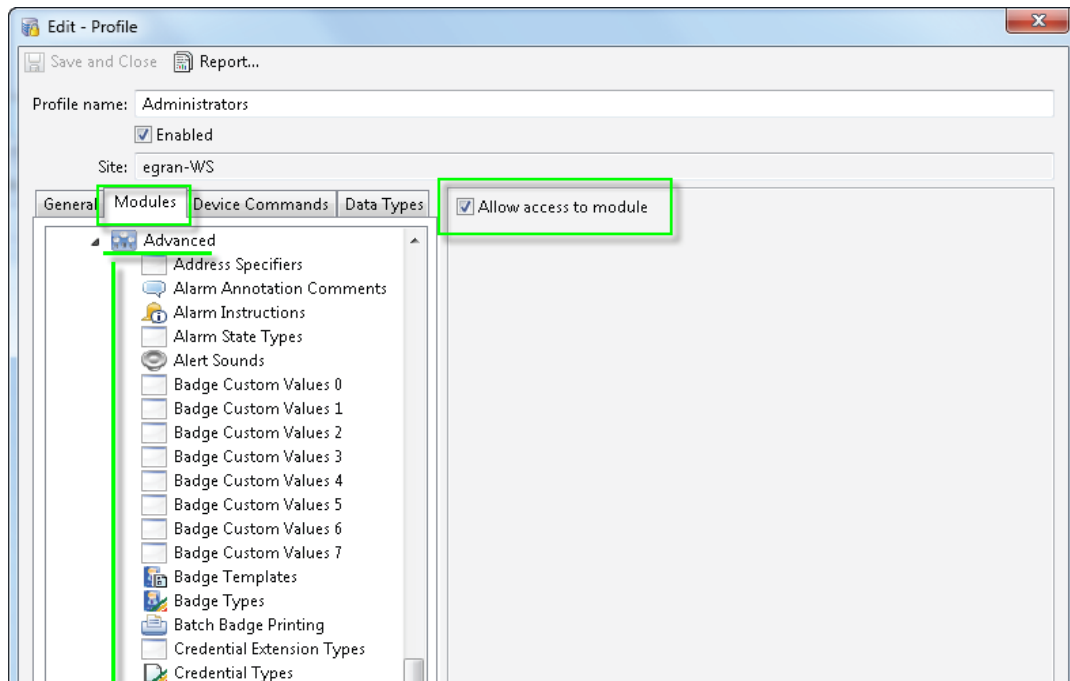

- Expand the **Advanced** category.
- Scroll down, and click on **Employee Statuses** to select it.

- f. Select the **Allow access to module** check box.
  - g. Click **Save and Close**.
- Step 2** To display the new menu, log out of ICPAM, and then log back in.
- a. Choose **Logout** from the **Options** menu.
  - b. Enter the username and password for a user assigned to the profile you just modified.
  - c. Select **Login**.
- Step 3** Select **Employee Statuses** from the **Admin** menu.
- Step 4** Create a new employee status entry.
- a. Click **Add**.
  - b. Enter the name of the new entry ([Figure 14-10](#)).
  - c. Select **Active** if user accounts with this status should be active. Deselect **Active** if the user accounts should be inactive.
  - d. Click **Save and Close**.

*Figure 14-10 Add Employee Status dialog*

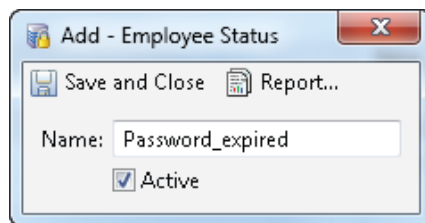

- e. Back in the Employee Statuses main window ([Figure 14-11](#)), verify that the new status appears and that the Active setting is true or false.

*Figure 14-11 Employee Statuses Window*

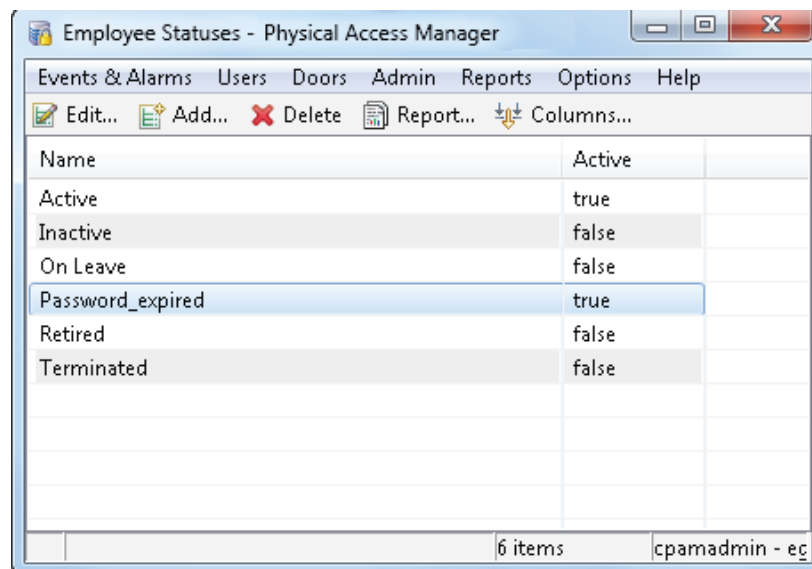



- b. Enter the workspace name and click **OK**.

The new workspace is created along with a Projects folder.



**Tip** **Root** and **Workspace** help organize your projects. (They do not serve any other purpose.)

- Step 3** To create a new EDI project, right-click on a **Projects** folder and select **New** (or highlight the folder and select **New** from the **Project** menu).
- Step 4** In the resulting **Choose Project Template** page of the New Project wizard, select one of the available project templates (as shown in [Figure 14-13](#)).

*Figure 14-13 EDI Studio: Choose Project Template*

- a. **Project name:** type a name for the project.
- b. **Project template:** select a template that defines the data type (such as SQL credential data)
- c. **Source DB:** select the database source (such as Oracle or MySQL).
- d. **Destination DB:** select the destination database (SQL or MySQL).



**Note**

Oracle databases do not support Boolean data types, so you must define numeric data types and use them as Boolean.

- e. Click **Next**.

**Step 5** Enter the source parameters, as shown in [Figure 14-14](#).

*Figure 14-14 EDI Studio: Enter Parameters for the Source Database*

- a. Type the **Database name**.
- b. Type the **User name** required to log in to the database.
- c. Type the **Password** for the database password.
- d. Type the **Server IP** address of the database server.
- e. Type the **TCP Port number** for the database server. Use a number between 1000 and 65536.
- f. Click **Next** or **Test Connection** to validate the server settings.
  - If the settings are valid, a message dialog stating **Test connection successful** appears.
  - If the settings are not valid, an error dialog stating **Test connection failed** appears. One or more of the parameters is incorrect. Work with your system administrator to obtain the correct settings, then test the connection again.

**Step 6** Map the database fields for the Destination [ICPAM] database with the database fields for the Source database.

- a. Enter the **Source table name** of the source database.
- b. Enter a Source field for all required **Destination [ICPAM]** fields (which are marked with an asterisk\*). The Destination fields vary depending on the type of data, as described in [Table 14-1](#).

*Table 14-1 Required Fields for Data Mapping*

<b>Data Type</b>	<b>Required Fields</b>
Organization	<b>Organization Data</b> <ul style="list-style-type: none"><li>• <b>name:</b> (primary key) Name of the organization.</li></ul> <b>Department Data</b> <ul style="list-style-type: none"><li>• <b>name:</b> (primary key) Name of the department.</li><li>• <b>orgName:</b> (primary key) Organization name</li></ul>

Table 14-1 Required Fields for Data Mapping (continued)

Data Type	Required Fields
Personnel	<ul style="list-style-type: none"> <li>• <b>site</b>: Site of the personnel record.</li> <li>• <b>firs_name</b>: User's first name.</li> <li>• <b>last_name</b>: User's last name</li> <li>• The valid values are: I, II, III, Jr., and Sr.</li> <li>• <b>govt_id</b>: (primary key) Government ID number. If the govt_id is a Social Security number, the length must be exactly nine digits (without dashes).</li> <li>• <b>govt_id_spec</b>: a unique id that can identify a personnel record. Valid values are SSN, FIN, and ID#.</li> <li>• <b>emp_status</b>: Employment status. The valid values are: active, inactive, on_leave, retired, and terminated. If your organization has additional employee status codes, such as <i>Active Password Expired</i>, you can manually add those codes to the bottom of the list: enter the ICPAM Value in the left column (it must be one of the 5 supported <b>emp_status</b> values), and then enter your organization's code in the right column.</li> <li>• The <b>emp_type</b> is not required, but has the following valid values: contractor, employee, employee_full_time, employee_part_time, intern, other, vendor, and visitor. <b>emp_type</b> is a type of employee.</li> </ul> <p><b>Note</b> The Region and Nationality fields be values already defined in system.</p>
Credential (Badge Records)	<p><b>Note</b> The primary keys are <b>badgeId</b> and <b>facilityCode</b>.</p> <ul style="list-style-type: none"> <li>• <b>badgeId</b>: (primary key) The badge ID.</li> <li>• <b>badgeTemplate</b>: Use this field to assign the parameters from a badge template in ICPAM to imported badges. This option is used when importing badges into ICPAM for the first time.</li> </ul> <p>For example, create or edit a badge template in ICPAM as described in <a href="#">Configuring Badge Templates, page 9-25</a>. This template can contain settings for fields such as access policy, facility code, badge type, watch level, and effective date. Enter the name of the badge template in the Source Attribute Value column for <b>badgeTemplate</b>. For example: KeyPad_BCD4, 26BitWiegandCT, 26BitWiegandKeyPadCT, etc.</p> <ul style="list-style-type: none"> <li>• <b>facilityCode</b>: (primary key) The facility code</li> <li>• <b>activationDate</b>: Activation date for the badge.</li> <li>• <b>expirationDate</b>: Date the badge expires. This date must be greater than the activation date.</li> <li>• <b>validity</b>: The valid values are: active, inactive, destroyed, lost, and stolen.</li> <li>• <b>role</b>: The user's role in the organization. The valid values are: employee, contractor, vendor, and temporary.</li> </ul>

- c. **Source**: Enter the corresponding field name for the source database. Enter a name for all required Destination fields, and any additional fields, if necessary.
- d. Click **Next**.



- e. For **Organization** data only: Enter the additional **Department Data** settings, and click **Next** again.
- Step 7** Define the default database values, and click **Next** to continue.
- Step 8** (Optional) If necessary, select an EDI Extension file (Figure 14-15), and click **Next**.

Figure 14-15 EDI Studio: EDI Extension

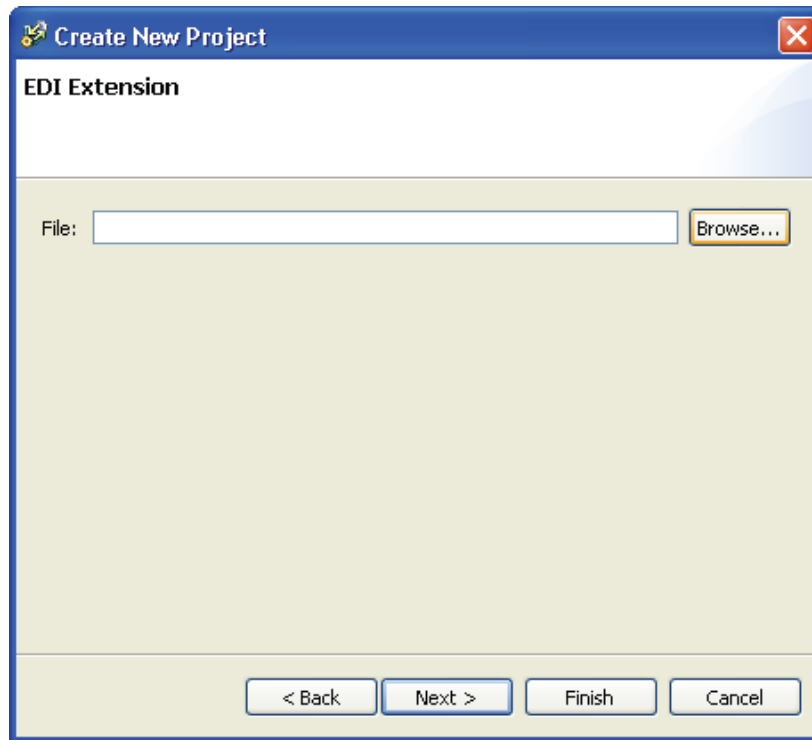

- Step 9** Choose a schedule to specify how often data will be synchronized, as shown in Figure 14-16.

Figure 14-16 EDI Studio: Choose Schedule

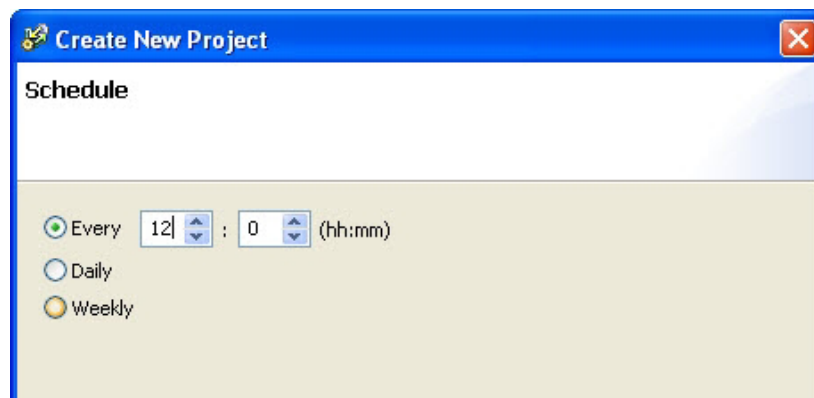

**Note** EDI actions are conducted according to the ICPAM appliance time and time zone settings (not the source database server settings).

- **Every hh:mm:** the data synchronization begins once every hour/minute specified.

- **Daily:** the data synchronization is conducted once a day.
- **Weekly:** the data synchronization is conducted once a week.



**Note** The minimum time frame to schedule a EDI job for synchronization is one hour.

- Step 10** Click **Finish** to create the new database project and return to the ICPAM Data Enterprise application window (Figure 14-12 on page 14-28).

The project is shown in the main window and the project file is saved to the default EDI project directory on your PC:

```
C:\Program Files\ICPAM Systems\EDI Studio\workspaces\Project_Folder\projects\.
```



**Tip**

An error message appears if any fields are incorrect or missing. Use the **Back** button to navigate to the screen and correct the entry. When you are done, click **Finish** from the window where the correction was made. (You do not need to return to the previous window.) The entries in all windows are preserved.

- Step 11** Import and start the EDI project in ICPAM.

See [Importing, Starting, and Monitoring EDI Projects in ICPAM, page 14-40](#).

## EDI Project Data Field Mapping

This is the mapping information on equivalent fields between the destination ICPAM database and the Source DB attributes.

**Table 14-2 Personnel Interface Data (Mandatory Fields)**

Column Name	Type	Length	Mandatory / Comments
Updated TS	Datetime		Mandatory
Created TS	Datetime		Mandatory
first_name	String	255	Mandatory
last_name	String	255	Mandatory
govt_id	String	255	Mandatory (employee ID)
govt_id_spec	String	255	Mandatory. Default mapping through GUI
emp_status	String	255	Mandatory. Transform values through GUI
Site	String	24	Default mapping through GUI
Photo	mediumblob (binary)		Only the JPEG format is supported

Table 14-3 Personnel Interface Table (Optional Fields)

Column Name	Type	Length	Optional / Comments
middle_name	String	255	Optional
Nickname	String	255	Optional
name_title	String	255	Optional
name_suffix	String	255	Optional
title_in_org	String	255	Optional
Org	String	255	Optional
Dept	String	255	Optional
user_id	String	255	Optional
emp_type	String	255	Optional
dob	Date		Optional
doh	Date		Optional
employee_number	String	255	Optional
comments	String	255	Optional
home_addr_line1	String	255	Optional
home_addr_line2	String	255	Optional
home_addr_city	String	255	Optional
home_addr_state_province	String	255	Optional
home_addr_country	String	255	Optional
work_addr_line1	String	255	Optional
work_addr_line2	String	255	Optional
work_addr_city	String	255	Optional
work_addr_state_province	String	255	Optional
work_addr_country	String	255	Optional
other_addr_line1	String	255	Optional
other_addr_line2	String	255	Optional
other_addr_city	String	255	Optional
other_addr_state_province	String	255	Optional
other_addr_countr	String	255	Optional
home_phone	String	255	Optional
work_phone	String	255	Optional
mobile_phone	String	255	Optional
other_phone	String	255	Optional
Fax	String	255	Optional

**Table 14-3 Personnel Interface Table (Optional Fields) (continued)**

Column Name	Type	Length	Optional / Comments
primary_email	String	255	Optional
secondary_email	String	255	Optional
other_email	String	255	Optional
customAttr 0-19	String	255	Optional
customDateAttr 0-3	String	255	Optional

**Table 14-4 Organization Interface Table**

Column Name	Type	Length	Mandatory / Optional / Comments
Updated TS	Datetime		Mandatory
Created TS	Datetime		Mandatory
name	String	255	Mandatory
comments	String	255	Optional

**Table 14-5 Department Interface Table**

Column Name	Type	Length	Mandatory / Optional / Comments
Updated TS	Datetime		Mandatory
Created TS	Datetime		Mandatory
name	String	255	Mandatory
OrgName	String	255	Mandatory (organization and department has parent child relationship)
comments	String	255	Optional

**Table 14-6 Badge Interface Table**

Column Name	Type	Length	Mandatory / Comments
Updated TS	Datetime		Mandatory
Created TS	Datetime		Mandatory
badgeID	String	255	Mandatory
Validity String	255		Mandatory
role	String	255	Mandatory. Transform values through GUI
assignedTo	String	255	Optional. To get the badge import to associate to the appropriate users in the ICPAM automatically. Please refer to the detailed process below.

Table 14-6 Badge Interface Table

Column Name	Type	Length	Mandatory / Comments
credTemplateId	String	255	Mandatory
facilityCode	Int	11	Optional
pincode	String	255	Optional
isExemptOk	bit	1	Optional
useLimit	Int	11	Optional
activationDate	Date		Optional
expirationDate	Date		Optional
Comments	String	255	Optional
tempDeactivationDate	Date		Optional
tempDeactivationDays	Int	11	Optional
antiPassbackExempt	bit	1	Optional
useADADoorStrikeTime	bit	1	Optional
executiveCredential	bit	1	Optional
customAttr 0-7	String	255	Optional
customDateAttr 0-1	Date		Optional

## Importing and Associating Badges to Corresponding Personnel Automatically

By default, the **assignedTo** field containing the default value as the personnel ID should appear in the EDI studio-mapping screen while creating a new project [SQL credential data template].

Figure 14-17 Creating a New Project

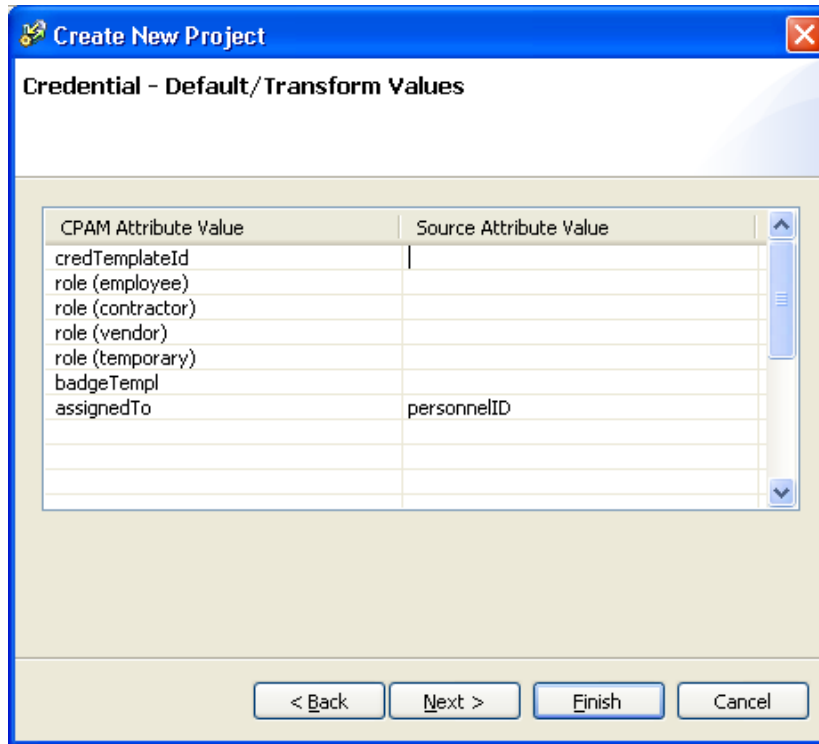

**Note** The personnel records in ICPAM should exist before importing the badge records.

**Steps to Associate**

**Step 1** When the Personnel records are imported into ICPAM through EDI, the Personnel module appears as below:

*Figure 14-18 Personnel module*

Last Name	First Name	Personnel ID	Personnel Type	Status	Badges
Brown	Tommy	1901	Visitor	Active	60299
Browning	Thomas	100	Employee - Full Time	Active	12345678
Grothman Pelton	Mary Jo	1900	Employee - Full Time	Active	60300, 652411146
Melendez	Joe	101	Employee - Full Time	Active	76282447
Mockridge	Jonathan	0975401275		Active	916346
Trump	Donald	123121234	Other	Active	60295

**Step 2** While importing, it is necessary to associate the badges correctly to the personnel/users. To achieve that, the Personnel ID column in the Badge table can be correlated to the Personnel table via EDI. To accomplish this, the assignedTo column in the EDI attribute screen should be used.

*Figure 14-19 Table mapping*

	hireddate	birthdate	badgeid	badgetype	personelid	status
1	2010-10-22 12:45:00.000	1982-05-24 00:00:00.000	1234	standard	2116	Employee
2	2012-02-06 12:45:00.000	1982-05-25 00:00:00.000	1235	standard	2117	Employee

*Figure 14-20 EDI Studio Attribute Screen*

Source table name*: BadPerRelation	
Destination [CPAM]	Source
pincode	
isExemptOk	
useLimit	
activationDate	
expirationDate	
comments	
assignedTo	personelid

**Step 3** Launch the ICPAM client.

**Step 4** Upload the created project, using the **EDI Administration** module.

- Step 5** Run the project.
- Step 6** Verify that the **assignedTo** field in the Badges module is mapped to the required personnel.
- 

## Importing, Starting, and Monitoring EDI Projects in ICPAM

This section includes the following information:

- [Importing and Starting EDI Projects](#), page 14-40
- [Verifying EDI Projects \(EDI Monitoring\)](#), page 14-42
- [Modifying a Running EDI Project](#), page 14-45
- [Restarting a Failed EDI Project](#), page 14-47
- [Summary of EDI Administration Functions](#), page 14-47

### Importing and Starting EDI Projects

After the EDI projects have been created, you must import the `.jar` project files into ICPAM, using the **EDI Administration** module.

- Step 1** Select **EDI Administration** from the **Admin** menu.

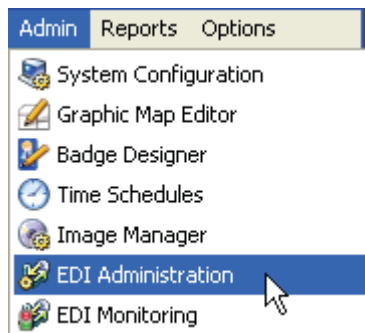



The **EDI Administration** main window appears, like in this example:

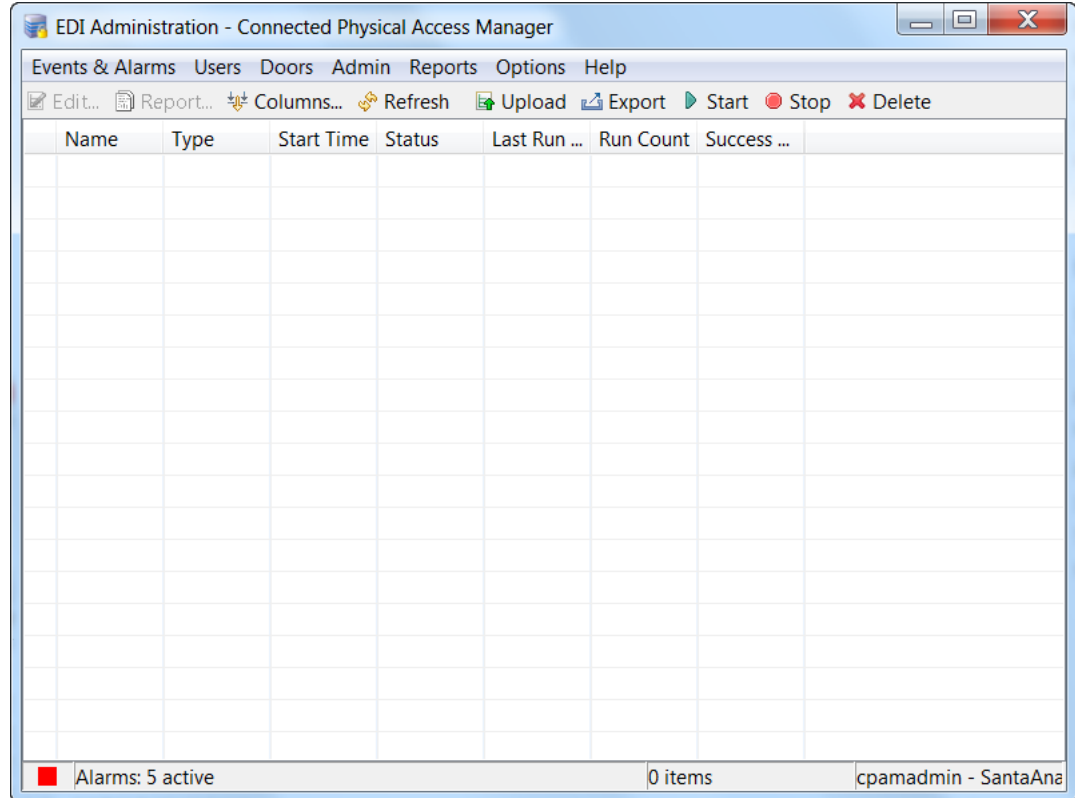

**Step 2** Click **Upload**, and select a project created using the EDI Desktop Studio.

The project `.jar` files are saved in the default EDI project directory on your PC:

```
C:\Program Files\ICPAM Systems\EDI Studio\workspaces\<project_folder_name>\projects\
```

**Step 3** After the file has been uploaded, click **Start**.

**Step 4** Select the start time:

- Select **Start Now** (default) to run the project immediately.
- Select **Start Later** to select a date and time to start the EDI project. The project will run at this time, and then at any scheduled times defined in the project file.

- (Optional) You can also select a **Data sync start time** to perform the data synchronization from a particular date and time entered. Click the **Data sync start time** field to open a pop-up calendar. Double-click the date when the data sync should begin. The date and current time will be entered in the field. Edit the date and/or time if necessary.

**Note** Active Directory EDI projects restart when the ICPAM appliance is stopped and restarted. All other projects will run on their normally scheduled time. If you do not want Active Directory projects to run after a server restart, stop the project(s) before restarting the server.

**Step 5** Verify that the project has started.

## Verifying EDI Projects (EDI Monitoring)

Use the following information to verify that the record import is working.

**Step 1** Select **EDI Monitoring** from the **Admin** menu (Figure 14-21).

*Figure 14-21 EDI Monitoring command*

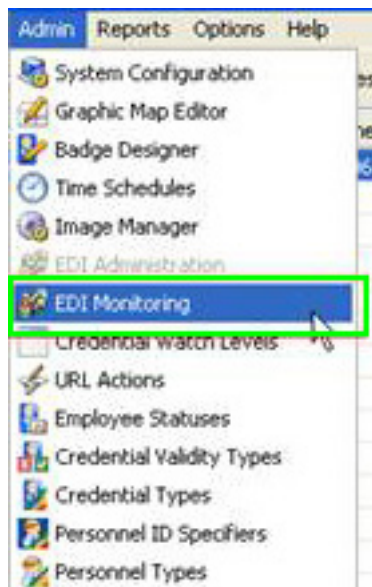

The following information is displayed for each record

Column	Description
<b>ID</b>	The EDI event ID number.
<b>Project Name</b>	The name of the EDI project that the event has defined in the EDI Desktop Studio.
<b>Project Type</b>	The type of data, such as personnel, badge, or organization records.
<b>Records Succeeded</b>	The number of records successfully updated during the integration event.
<b>Failed Records</b>	The number of records that were not updated by the integration event. Failed record details are stored in the log files.
<b>Extract Type</b>	The type of data extraction including interface or core (see the following step).
<b>Start Time</b>	The date and time when the data integration event began.
<b>End Time</b>	The date and time when the data integration event ended.

- Step 2** Review the EDI projects on the **EDI Monitoring** window (see [Figure 14-22](#)). There are two types of Extract Types:
- **Interface**: this occurs when the ICPAM server connects to the remote data source and retrieves the records that have been added or modified since the last time the Interface extract was executed.
  - **Core**: this occurs when the ICPAM server validates the records retrieved by the interface process, and then edits the ICPAM personnel database to make the additions, deletions, or edits.

*Figure 14-22 EDI Monitoring window*

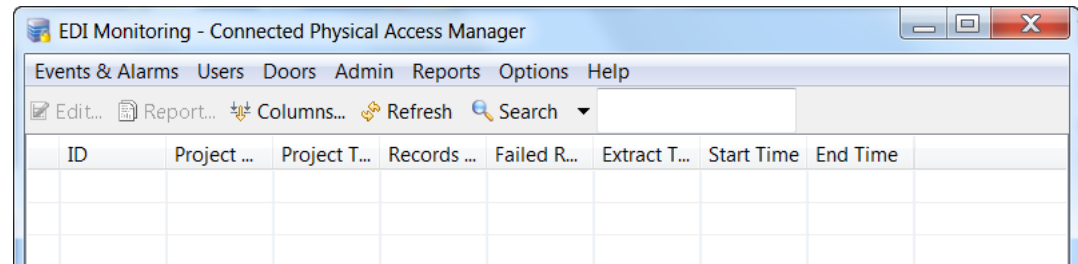

If the Interface entry shows success, but the core does not, something in the extracted record is not compatible with the mapping between the Active Directory and ICPAM databases.

- Step 3** To troubleshoot the errors and view additional error details, select **Error Monitoring** from the **Admin** menu ([Figure 14-23](#)).

Figure 14-23 EDI Error Monitoring command

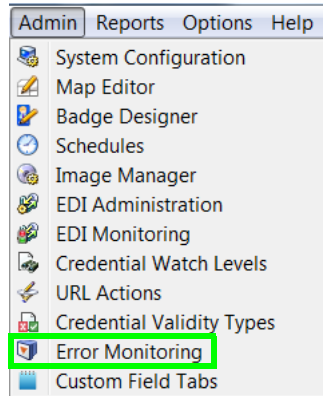

- Step 4** The **Error Monitoring** window displays entries for each failed record, as shown in Figure 14-24. The Messages column includes text regarding the cause. For example: “Site is null” messages occur if the site name was not entered on the **Default/Transform** values screen of the EDI Studio project.

Figure 14-24 Error Monitoring window

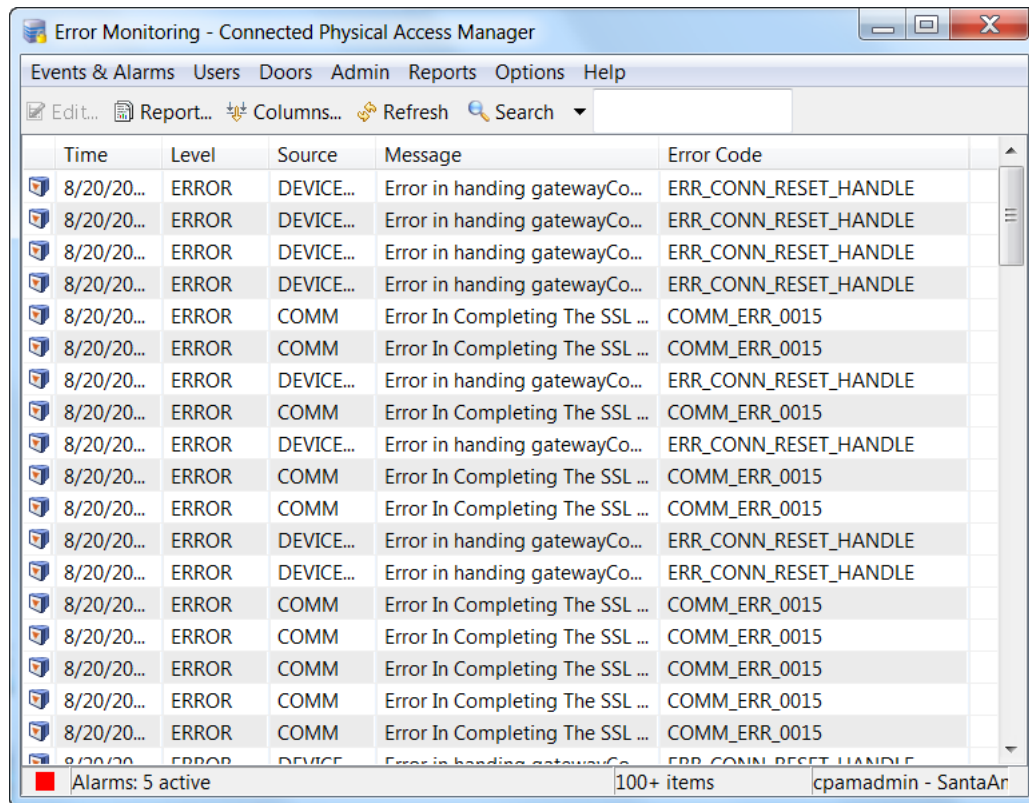

In addition, the following can occur:

Record updates in AD include a timestamp for the edit. When the ICPAM server connects, it compares the timestamp of the last edit in AD with what the last edit is that ICPAM knows about. If the AD timestamp is newer, the record is extracted.

After the record has been extracted from AD into ICPAM, the fields are checked for validity during the Core extract. For example, if the AD last name (attribute `sn`) contains a number, ICPAM should fail to import that record into the personnel database because a valid last name cannot contain a number.

- Step 5** After you have determined the cause of the error, modify the project. See [Modifying a Running EDI Project](#), page 14-45.

If an EDI data integration project fails, identify and resolve the problem, and then complete the instructions in [Restarting a Failed EDI Project](#), page 14-47.

## Modifying a Running EDI Project

To modify an EDI project that is running, do the following:

- Step 1** Stop the project:
- Select **EDI Administration** from the **Admin** menu.
  - Select the project and click **Stop**.
- Step 2** Click **Export** to save the `.jar` project file. Save the file in the in the default EDI project directory on your PC:
- ```
C:\Program Files\ICPAM Systems\EDI Studio\workspaces\Project_Folder\projects\.
```
- Step 3** Edit the project in EDI Studio:
- Open the EDI Studio application on your PC.
  - Select the project in the left pane, and click **Edit** below the right pane.

*Figure 14-25 Editing EDI Projects*

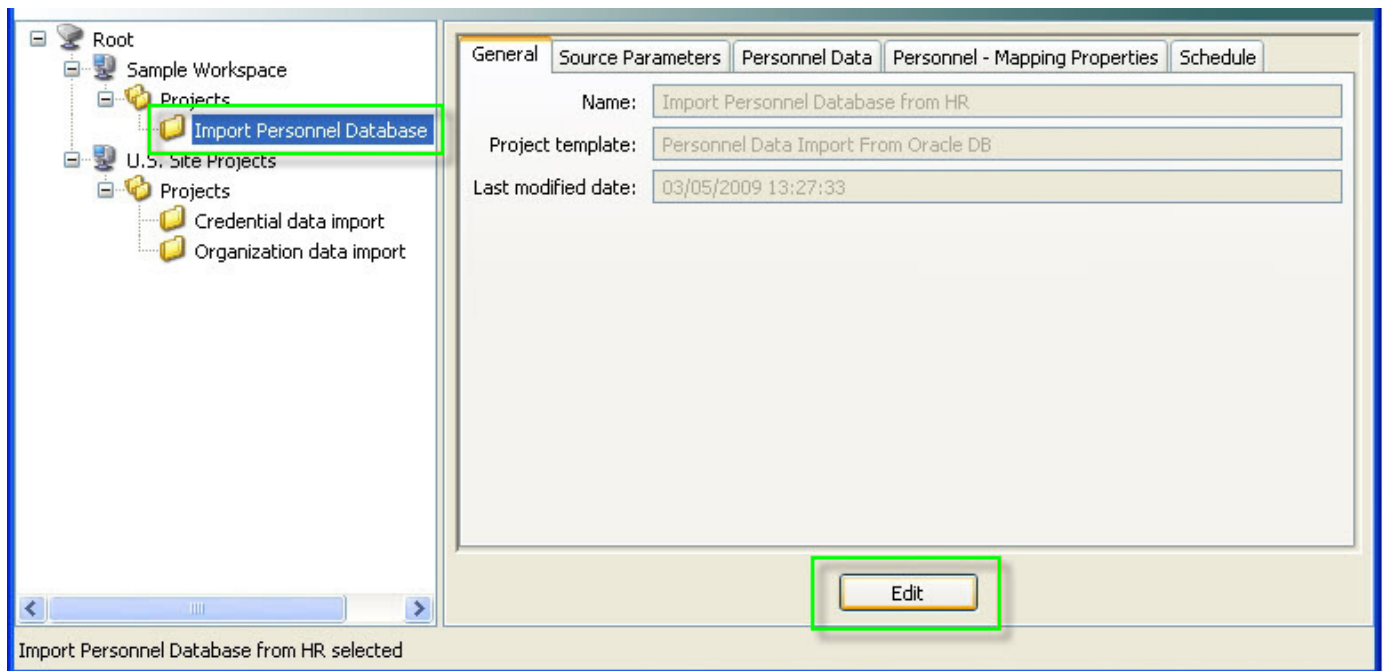

- Edit the settings as necessary, and click **Save**.



**Tip** For field descriptions, refer to [Creating Active Directory Database Integration Projects Using EDI Studio, page 14-16](#).

- Step 4** Upload the modified project to ICPAM:
- Select **EDI Administration** from the **Admin** menu.
  - Click **Upload** and select the .jar file that was saved in the default EDI project directory on your PC:  
`C:\Program Files\ICPAM Systems\EDI Studio\workspaces\<Project_Folder>\projects\.`
- Note** Files can be saved to and uploaded from other locations.
- Step 5** Select the project, click **Start**, and specify the start time (Figure 14-26):

*Figure 14-26 EDI Administration - Project Start Time dialog*

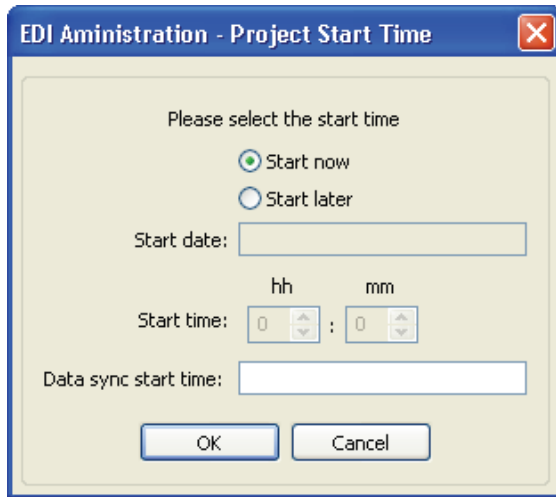

- Select **Start Now** (default) to run the project immediately.
- Select **Start Later** to select a date and time to start the EDI project. The project will run at this time, and then at any scheduled time defined in the project file.
- (Optional) You can also select a **Data sync start time** to perform the data synchronization from a particular date and time entered. Click the **Data sync start time** field to open a pop-up calendar. Double-click the date when the data sync should begin. The date and current time will be entered in the field. Edit the date and/or time if necessary.

## Restarting a Failed EDI Project

If an EDI data integration project fails, identify and resolve the problem before restarting the project.

### Resolving Active Directory Issues

If an error in the Active Directory record occurs, update the AD record. The EDI project will run according to the defined schedule. To force the project to run immediately, stop and then restart the project. See [Summary of EDI Administration Functions, page 14-47](#).

### Resolving ICPAM or EDI Studio Issues

If an error occurs in the ICPAM database, do the following.

- 
- Step 1** Correct the issue. For example:
- If no organization values exist in the ICPAM records.  
When organization and department values are included in an imported personnel record, those values must already exist in the ICPAM configuration. Before creating the EDI project, add the Organization values by manually creating them or through a data import. See [Editing Organization and Department Lists, page 9-12](#) for more information.
  - If the project mapping is incorrect. See [Modifying a Running EDI Project, page 14-45](#) to correct mapping issues.
- Step 2** Delete the project in the EDI Administration.
- a. Select **EDI Administration** from the **Admin** menu.
  - b. Select the project, and click **Delete**.
- Step 3** Re-import and start the project. See [Importing and Starting EDI Projects, page 14-40](#).
- 

## Summary of EDI Administration Functions

- [Column Descriptions](#)
- [EDI Administration Functions, page 14-48](#)

### Column Descriptions

The **EDI Administration** window includes the following columns:

| Column                   | Description                                                                              |
|--------------------------|------------------------------------------------------------------------------------------|
| <b>Name</b>              | The data integration project name, as defined in the EDI Desktop Studio.                 |
| <b>Type</b>              | The type of data, such as personnel, badge, or organization records.                     |
| <b>Recent Start Time</b> | The most recent time that data integration began for the project.                        |
| <b>Status</b>            | Specifies whether the project is running, stopped, or scheduled.                         |
| <b>Last Run Date</b>     | The most recent date that the project was executed (successful or unsuccessful attempt). |

| Column                   | Description                                                                          |
|--------------------------|--------------------------------------------------------------------------------------|
| <b>Run Count</b>         | The number of times the project has been run (successful and unsuccessful attempts). |
| <b>Success Run Count</b> | The number of times the project has been successfully run.                           |

### EDI Administration Functions

The following functions are available from the toolbar above the project list:

| Function       | Description                                                                                                                                                                                                                                                                                                                                                                                                                                                    |
|----------------|----------------------------------------------------------------------------------------------------------------------------------------------------------------------------------------------------------------------------------------------------------------------------------------------------------------------------------------------------------------------------------------------------------------------------------------------------------------|
| <b>Refresh</b> | Refresh the window to display current information.                                                                                                                                                                                                                                                                                                                                                                                                             |
| <b>Upload</b>  | Upload a new or modified project from the EDI Desktop Studio. The project .jar files are saved in the default EDI project directory on your PC:<br><br>C:\Program Files\ICPAM Systems\EDI Studio\workspaces\<br>Project_Folder\projects\                                                                                                                                                                                                                       |
| <b>Export</b>  | Exports the project in the .jar file format.                                                                                                                                                                                                                                                                                                                                                                                                                   |
| <b>Start</b>   | Runs a data integration project now, or at a specified time.<br><br><b>Tip</b> To create a recurring schedule for EDI projects, use EDI Studio.<br><br><b>Note</b> Active Directory EDI projects restart when the ICPAM appliance is stopped and restarted. All other projects will run on their normally scheduled time. If you do not want Active Directory projects to run after an ICPAM server restart, stop the project(s) before restarting the server. |
| <b>Stop</b>    | Disables the project and stops data integration from running. A project cannot be stopped if currently running an integration. To update a project, you must first stop the project, modify it in EDI Studio, and then upload the revised .jar file.                                                                                                                                                                                                           |
| <b>Delete</b>  | Removes the data integration project from ICPAM. The project remains in the EDI Desktop Studio.                                                                                                                                                                                                                                                                                                                                                                |



# Accessing the SQL Database

The ICPAM SQL database can be accessed by 3rd-party Time and Attendance (T&A) systems to view personnel, time and attendance, and user tracking data. The database views are not visible by default. Use the MySQL Query browser to display the database views.



## Caution

Do not modify the SQL tables. Use the following instructions to browse the tables only. Changing the tables or data can result in ICPAM errors or system failures.

To view the ICPAM SQL database, complete the following procedure:

- Step 1** If necessary, contact Identiv technical support to obtain the database username, password, host, and schema.
- Step 2** Install and launch the MySQL Query Browser, and enter the server and login information supplied by Identiv technical support.
- Step 3** In the Schemata pane (right column), expand the vxdb entry and scroll down to the bottom of the list to display the entries for `personnel_vw`, `time_attendance_vw`, and `user_tracking_vw` (Figure 14-27).

Figure 14-27 MySQL Query Browser

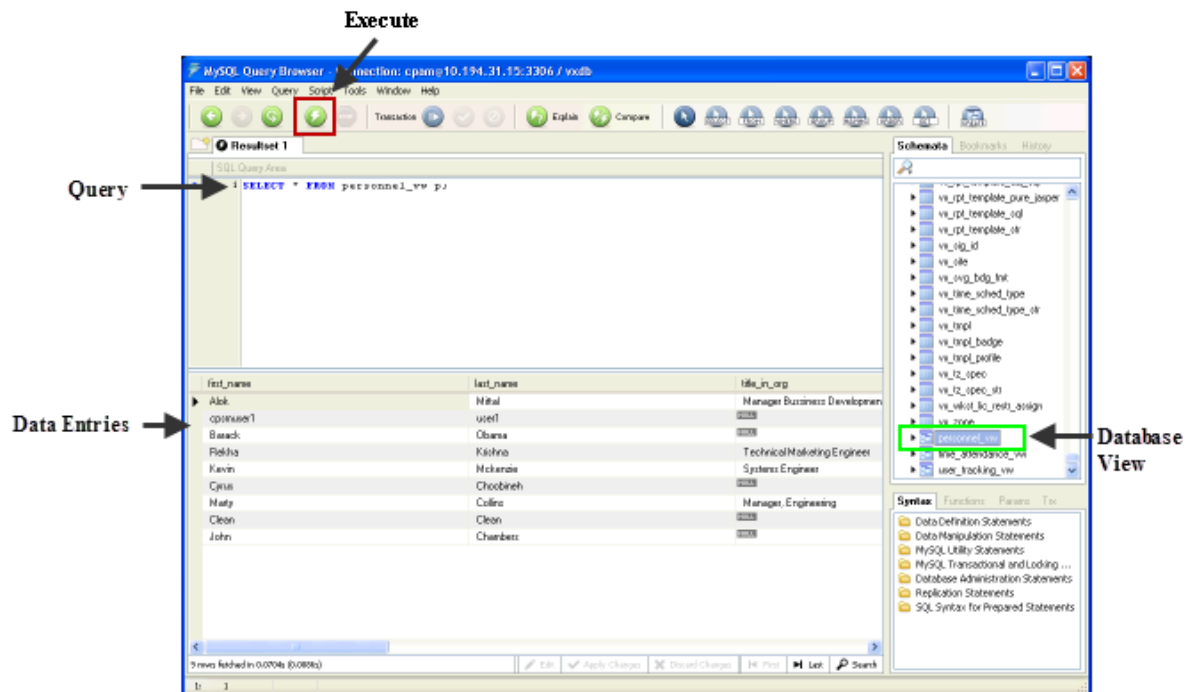

- Step 4** To view the database entries:
  - a. Double-click on the table name to enter a query in the Query field.
  - b. Click the **Execute** button.

The data is shown in the browsing area.

See the following topics for examples of the SQL data views:

- [Personnel view, page 14-50](#)
- [Time and Attendance view, page 14-51](#)
- [User Tracking view, page 14-52](#)

## Personnel view

The Personnel view ([Figure 14-28](#)) provides personnel information such as first name, last name, user id, personnel id, photo image, and the image type.

*Figure 14-28 Personnel view*

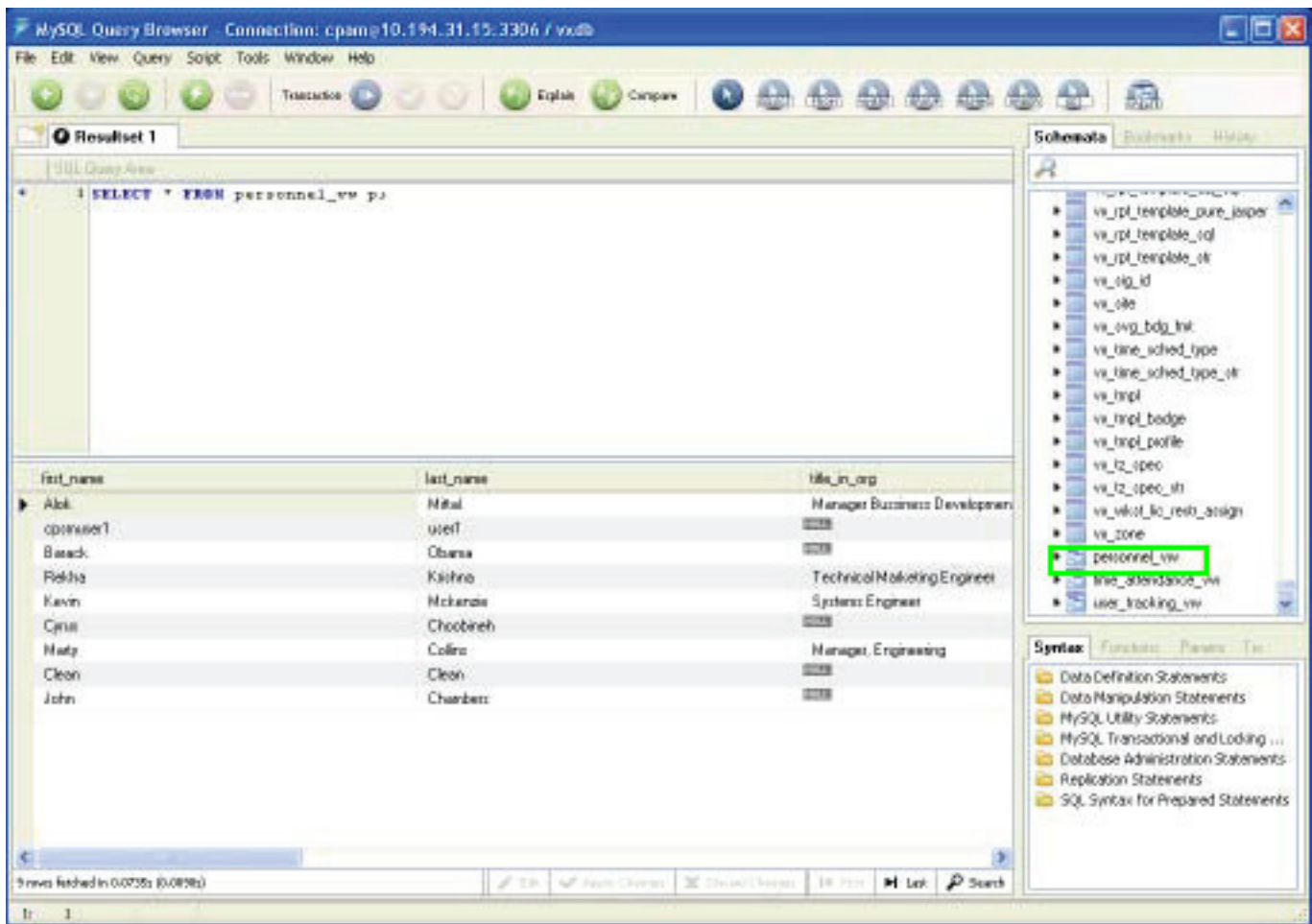

## Time and Attendance view

The Time and Attendance view (Figure 14-29) provides information on user entry and exit through the doors. The information in this view includes first name, last name, personnel id, user id, door name, door location, reader name, entry or exit reader type, and the entry/exit time for the user.

You can optionally select all or partial data based on first name, last name, reader name, or a combination of these fields.

Figure 14-29 Time and Attendance view

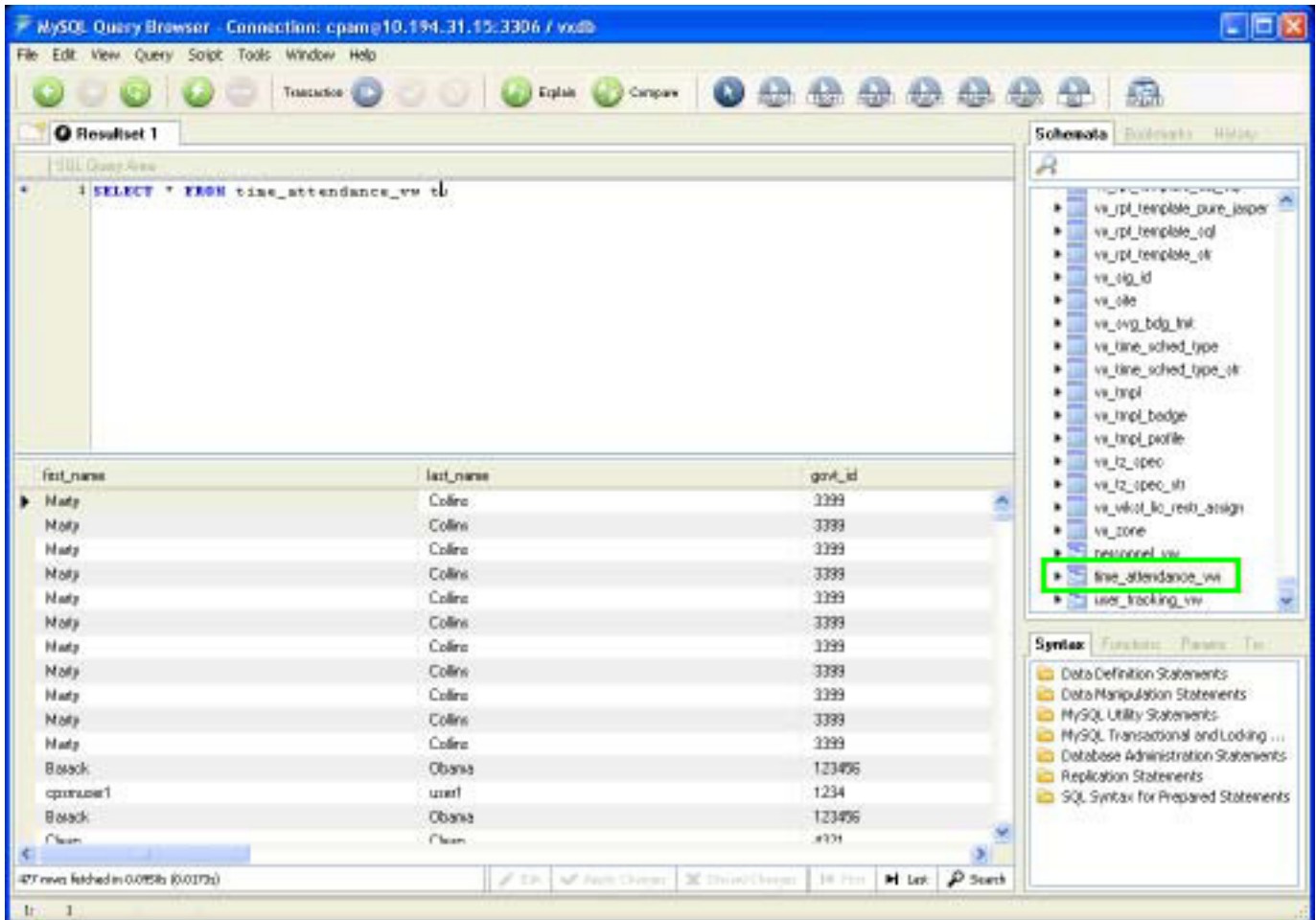

## User Tracking view

The User Tracking view (Figure 14-30) provides information regarding a user's most recent use of the access control system, including the first name, last name, personnel ID, user ID, door name, door location, reader name, entry or exit reader type, and the door entry time.

You can optionally select all or partial data based on first name, last name, personnel ID, or a combination of these fields.

Figure 14-30 User Tracking view

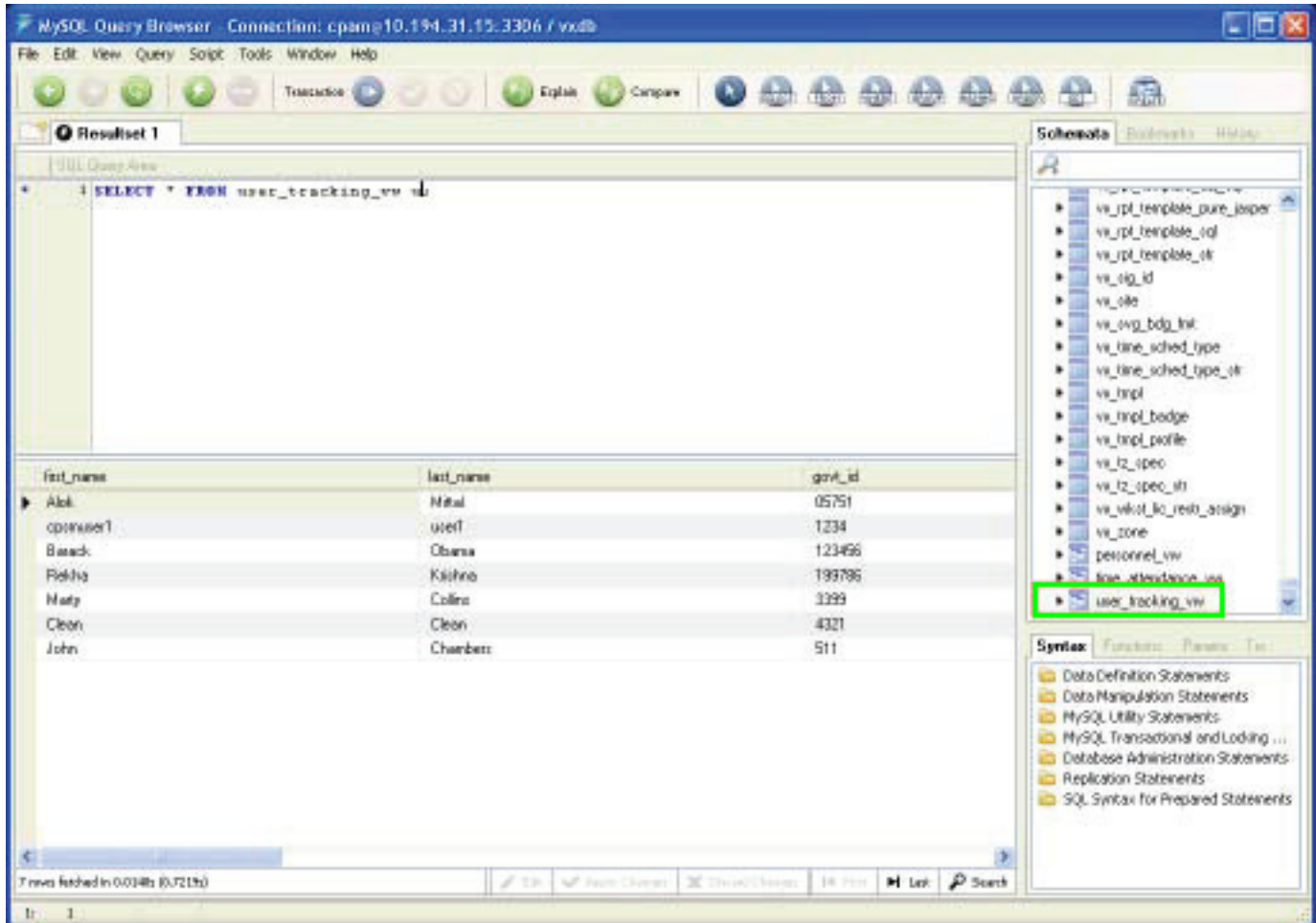

## Video Monitoring

---

This chapter describes how to view live and recorded video streams from security cameras configured in the Cisco Video Surveillance Manager (VSM) system. Using ICPAM, you can associate these cameras with a door, and then view live and archived video for that door. While viewing live video, you can also invoke a door command, or use the pan, tilt, and zoom (PTZ) controls, if available on the camera.

For example, if an alarm occurs, you can view an archived video clip when the alarm occurred, or open a live video stream for a camera associated with the door. Command options in the video player enable you to perform actions such as securing or opening the door. For more information about the Video Surveillance Manager, go to the [Cisco Network-Centric Video Surveillance Products](#) Web site.



Note

---

Starting with the ICPAM 2.1 release, version 6X of the Cisco VSM Camera Driver is no longer supported. (You must upgrade to version 7X of the driver.)

---

If a camera is removed from the VSM configuration then it is deleted completely from ICPAM, provided the camera is not associated with any devices, CCTV camera arrangements, or uncleared alarms. We recommend that you do not manually remove or delete cameras from the ICPAM configuration. Use the `synchronize` command to update the camera inventory, if necessary, as described in [Managing the Camera Inventory](#), page 15-27.

## Camera Manager in ICPAM

If the profile enhancement feature is set in the system configuration settings (see [Logins page of the System Configuration window](#), page 17-11), the following changes are impacted in this module:

- Only those camera drivers present in the user's hierarchical location are displayed.
- The location-restricted users can view all cameras in the camera manager, but can only access cameras for their location.
- The `cpamadmin` assigns the location of the cameras to a location-restricted user.
- When a camera driver is associated to a specific location, as a location-restricted user you will be able to view your set of privileged cameras under the system driver that is populated only in your location i.e other location-restricted users cannot view the system driver.



Note

---

Problems may occur when viewing video from analog cameras that use Cisco Stream Manager IP Gateway Encoder CIVS-SGxx. Contact your Identiv support representative for details.

---

**Contents**

- [Enabling Video Monitoring, page 15-2](#)
  - [Configuring the Camera Driver, page 15-3](#)
  - [Associating Cameras with Doors and Devices, page 15-7](#)
  - [Installing the Cisco VSOM Video Client Desktop Application, page 15-11](#)
- [Viewing Video, page 15-13](#)
  - [Viewing Live Video in a Grid Arrangement, page 15-14](#)
  - [Viewing Video for an Event, page 15-21](#)
  - [Viewing Event Video on a VSM Camera Driver 7X, page 15-22](#)
- [Managing the Camera Inventory, page 15-27](#)
- [Updating the Camera Inventory, page 15-27](#)
- [Deleting the Cisco VSM Cameras, page 15-29](#)
- [Deleting Individual Cameras, page 15-33](#)
- [Recording Motion Events from Cisco VSM Cameras, page 15-35](#)

## Enabling Video Monitoring

To enable video viewing in ICPAM, add the camera driver and associate the Cisco VSM cameras with specific doors and devices.

In addition, install the Cisco VSOM Video Client on each workstation. This player includes the ActiveX controls required for event video viewing. Reinstall the player anytime the Cisco VSM server is upgraded.

Complete the following instructions to enable video monitoring:

- [Configuring the Camera Driver, page 15-3](#)
- [Associating Cameras with Doors and Devices, page 15-7](#)
- [PC Workstation Requirements for Live Video Viewing, page 15-11](#)
- [Installing the Cisco VSOM Video Client Desktop Application, page 15-11](#)

## Configuring the Camera Driver

To add the VSM Camera Driver to enable video sharing and playback with the Cisco VSM system:

- Step 1** Select **Hardware - Tree** from the **Doors** menu.

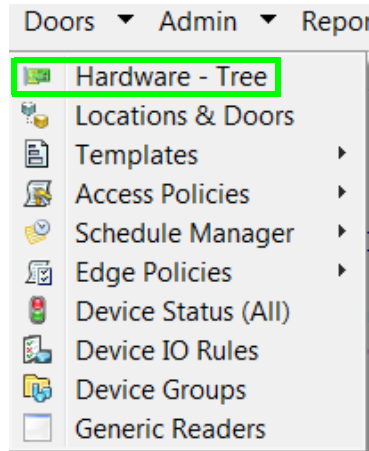

- Step 2** Right-click on the **Driver Manager** and select the **New Cisco VSM Camera Driver 7X...** command.

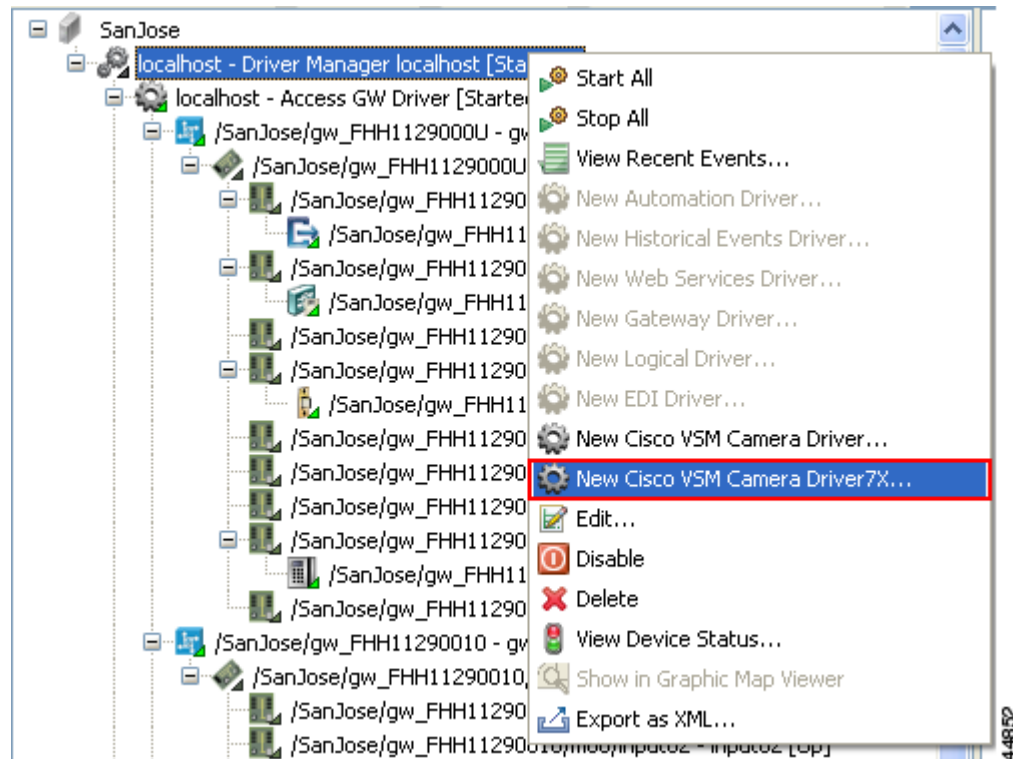

**Step 3** Enter the driver name in the properties window. For example: `Cisco VSM Camera Driver7x`.



**Step 4** Verify that the **Enabled** check box is selected (default).



**Tip** The VSM Config tab displays VSM server settings.

**Step 5** Switch to the camera's **Player Preferences**: page, and specify the following settings:

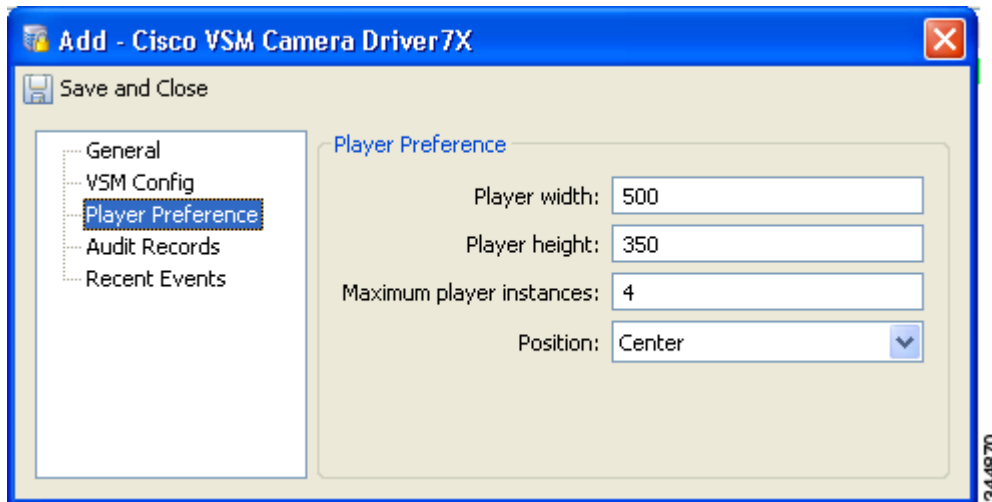

- **Player width**: the width of the video player in pixels.
- **Player height**: the height of the video player in pixels.
- **Maximum player instances**: limits the number of simultaneous video players that can be open on the desktop at a time. For version 7x, type a number from 1 to 4.  
See also [PC Workstation Requirements for Live Video Viewing, page 15-11](#).
- **Position**: the position on the screen where the video player appears. For example, if the position is set to **Center**, the video player opens in the center of the screen each time it is launched.

**Step 6** Click **Save and Close** to save your changes and close this dialog.



**Step 7** Right-click the **VSM Camera Driver** and select **Start** to enable the ICPAM video features.

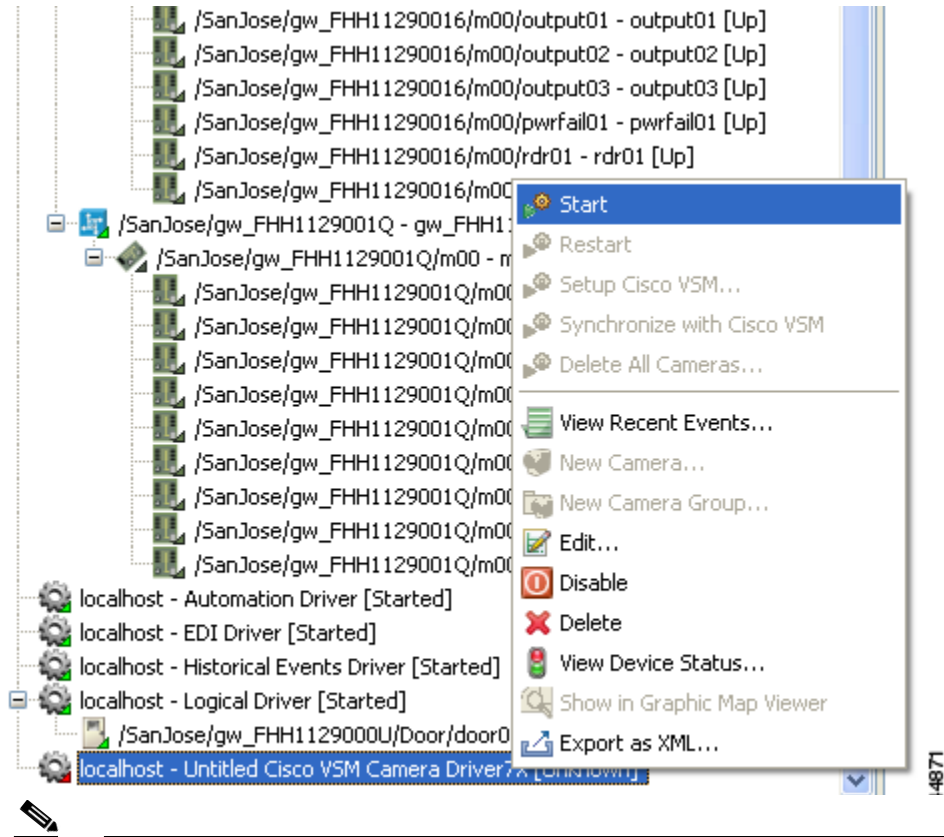

**Note** Verify that the driver status changed to *Started*.

**Step 8** Right-click the **Cisco VSM Camera Driver 7X** and select **Setup Cisco VSM**.

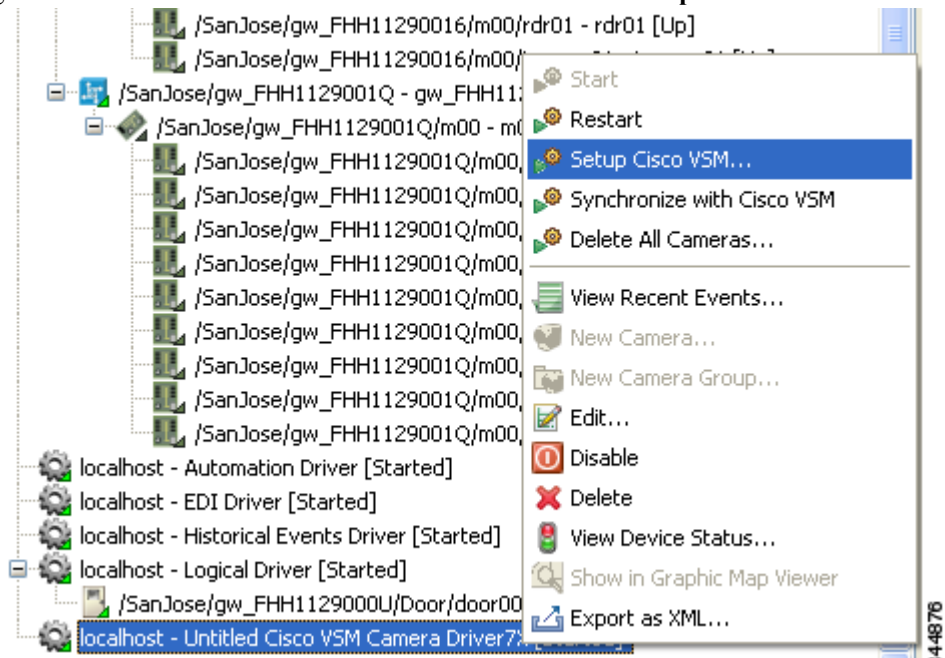

**Step 9** In the resulting **VSM Config** dialog, type the **Server Name**, **User Name**, and **Password**, then click **OK**.



**Tip** These fields are disabled if the camera driver was previously set up and includes cameras.

**Step 10** Right-click the **VSM Camera Driver** and select **Synchronize with Cisco VSM** to populate ICPAM with the Cisco VSM cameras.

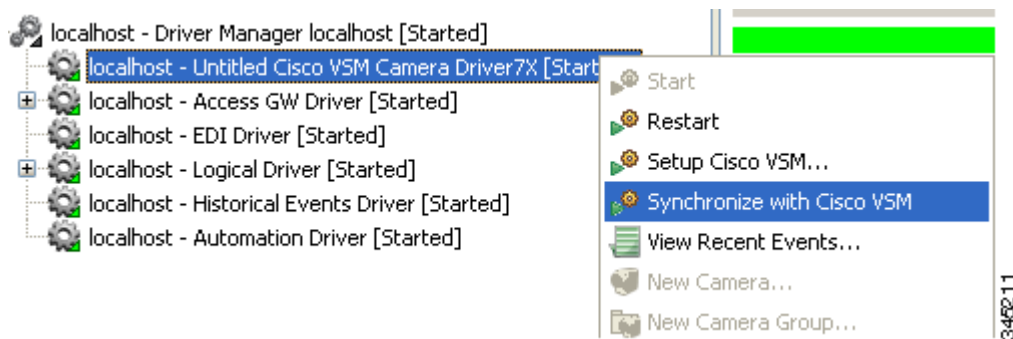

**Step 11** Verify that the Cisco VSM cameras appear as children of the Camera Driver.

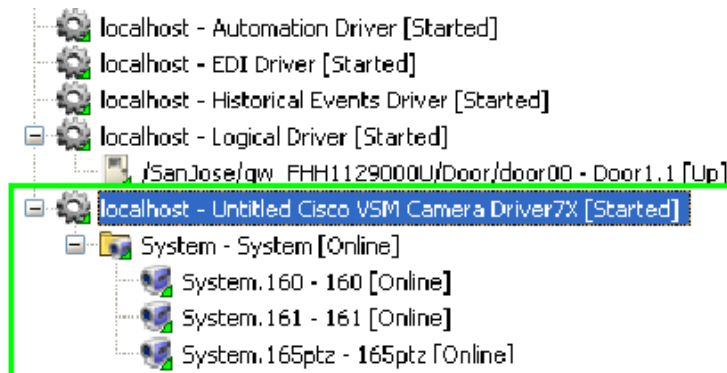

If the cameras do not appear, see [Updating the Camera Inventory](#), page 15-27.



**Note** Cameras in ICPAM are organized in the same camera groups as Cisco VSM. In ICPAM, each camera can only appear in one group. In Cisco VSM, cameras can appear in multiple groups.

**Note**

If a camera is deleted from the Cisco VSM configuration, it is disabled in ICPAM, but not removed. We recommend that you do not manually remove or delete cameras from the ICPAM configuration. Use the synchronize command to update the camera inventory.

**Note**

If a camera is removed from the VSM configuration then it is deleted completely from ICPAM, provided the camera is not associated with any devices / map / CCTV Camera Arrangements / uncleared Alarms.

**Note**

The ICPAM client must be running on Windows 7 to view video from the cameras under the 7X driver.

## Associating Cameras with Doors and Devices

When a camera is associated with a door or device, you can view recorded video clips for the events that occur on that device, or open a live video stream for the camera from event entries. When viewing live video, you can also invoke commands for the door or device.

For example, if you assign a camera to the door configuration `Lab 1`, you can right-click an event for that door to view live or recorded video for that door.

To associate a camera with a door or device, do the following:

- Step 1** Select **Devices in Camera View** from the **Events & Alarms** menu, in the **Video** submenu.

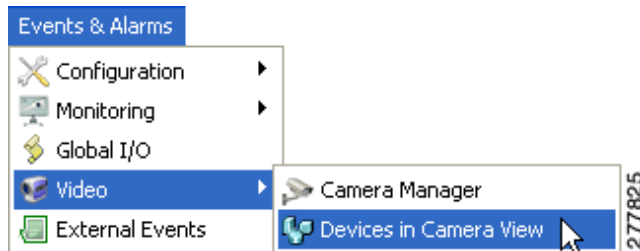

- Step 2** In the resulting window, drag-and-drop the devices and doors from the left pane to the cameras listed in the right pane.

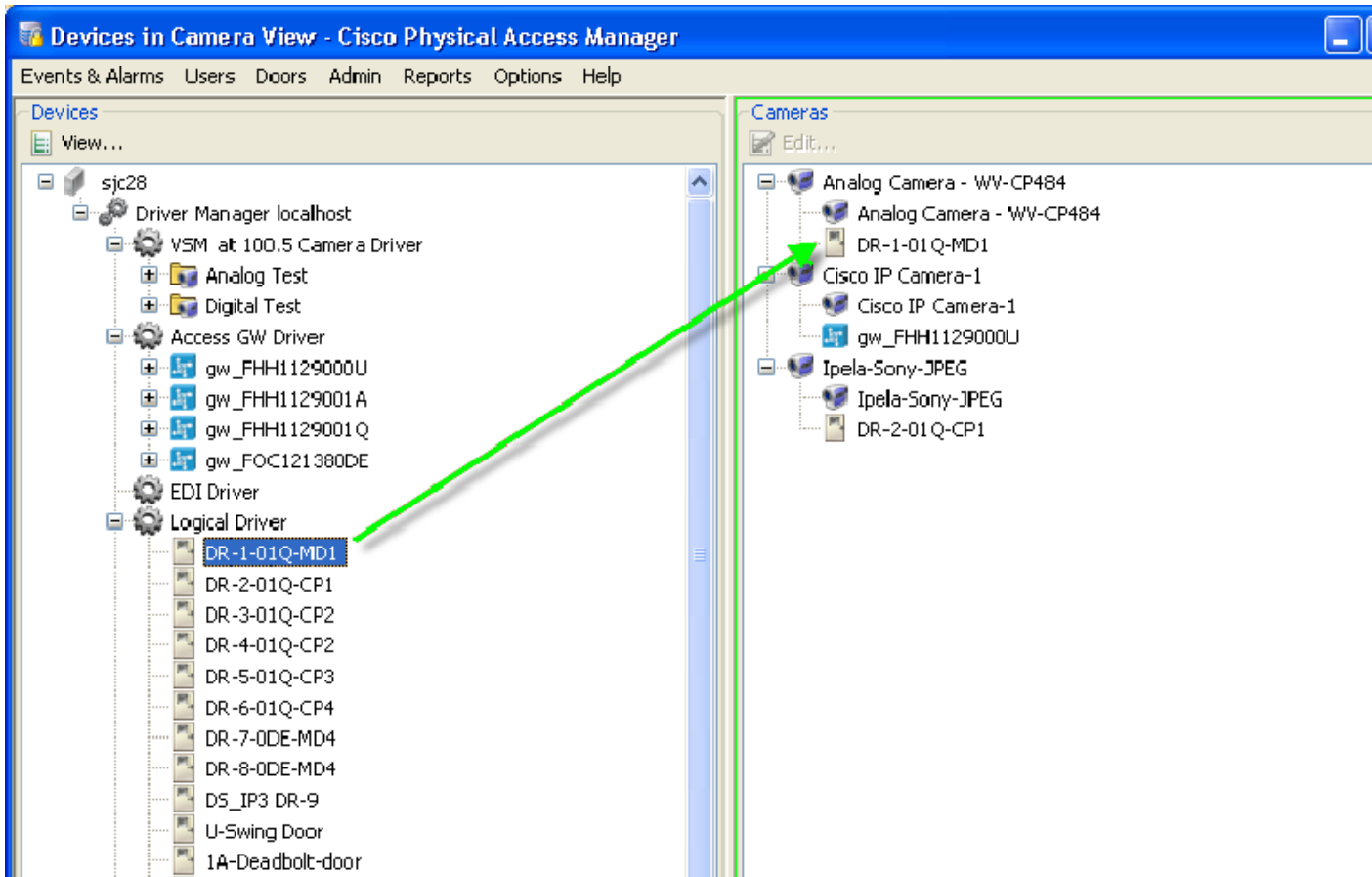

You can associate cameras with more than one device, and devices can be associated to more than one camera.



**Tip** Be sure to associate cameras only with devices that are in the camera's view.



**Note** If the correct cameras do not appear, see [Updating the Camera Inventory, page 15-27](#).

- Step 3** (Optional) You can also associate cameras with devices by editing the camera properties.
- Double-click a specific camera in the Video window or the Hardware - Tree window.
  - In the resulting window, switch to the **Devices in View** page.
  - Check the devices to be associated with the selected camera.
- Associated cameras are listed in the far-right table.

d. Click **Save and Close**.

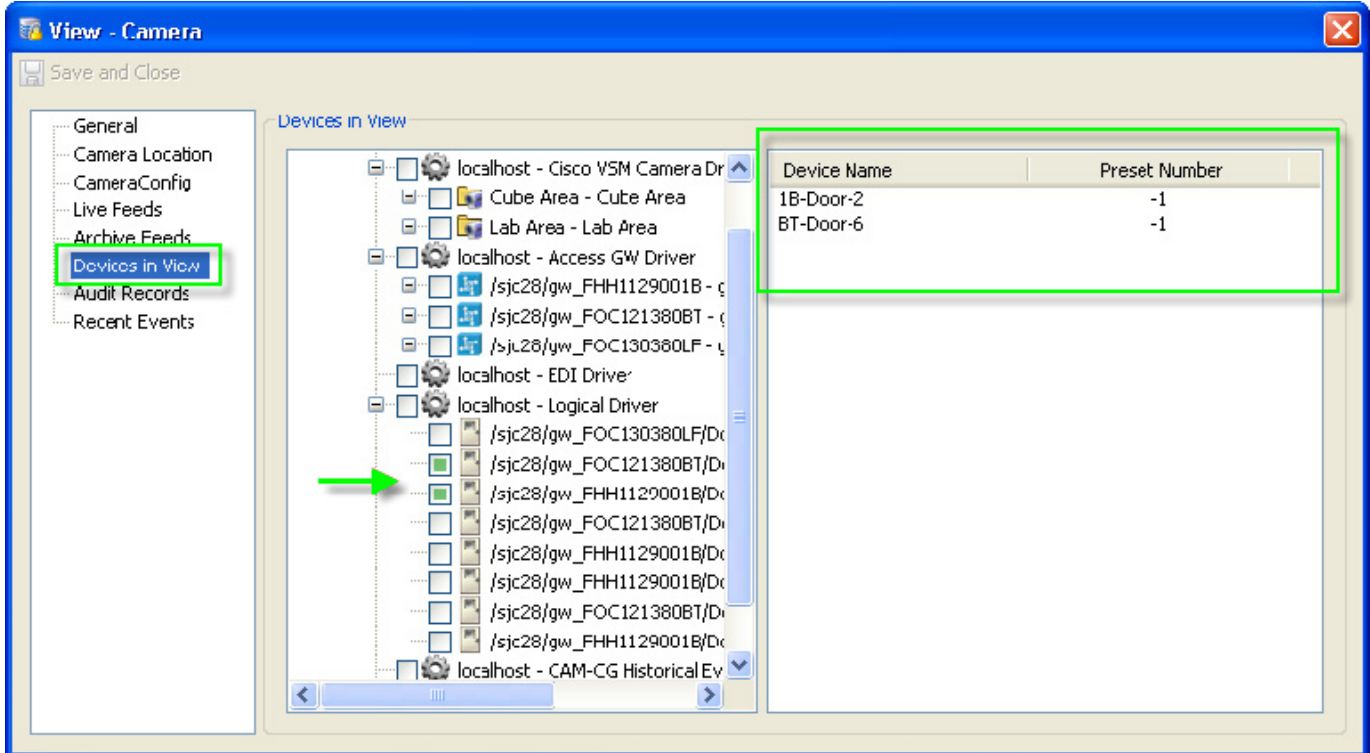

**Step 4** (Optional) Exit and relaunch the ICPAM client, to ensure that the camera associations appear correctly in the Events window.

**Tip**

In the Events main window, you can display a Video column that indicates whether a camera is associated with a door or device. Click **Columns** in the menu bar, check the **Video** box, and click **OK**. The Video column displays three dots if a camera is associated with the door or device.

| Time                   | Description                            | Video | Device    | Address      |
|------------------------|----------------------------------------|-------|-----------|--------------|
| 1/11/2010 14:54:33.000 | Badge credential template doesn't m... | ...   | 1B-Door-2 | /sjc28/gw_FT |
| 1/11/2010 14:54:17.000 | Badge credential template doesn't m... | ...   | 1B-Door-2 | /sjc28/gw_FT |
| 1/11/2010 14:54:02.000 | Badge credential template doesn't m... | ...   | 1B-Door-2 | /sjc28/gw_FT |
| 1/11/2010 14:53:46.000 | Badge credential template doesn't m... | ...   | 1B-Door-2 | /sjc28/gw_FT |
| 1/11/2010 14:53:34.000 | Door Not Used                          | ...   | 1B-Door-2 | /sjc28/gw_FT |
| 1/11/2010 14:53:31.000 | Door Grant Access                      | ...   | 1B-Door-2 | /sjc28/gw_FT |
| 1/11/2010 14:53:19.000 | Door Not Used                          | ...   | 1B-Door-2 | /sjc28/gw_FT |
| 1/11/2010 14:53:16.000 | Door Grant Access                      | ...   | 1B-Door-2 | /sjc28/gw_FT |
| 1/11/2010 14:53:03.000 | Door Not Used                          | ...   | 1B-Door-2 | /sjc28/gw_FT |
| 1/11/2010 14:53:00.000 | Door Grant Access                      | ...   | 1B-Door-2 | /sjc28/gw_FT |
| 1/11/2010 14:52:48.000 | Door Not Used                          | ...   | 1B-Door-2 | /sjc28/gw_FT |
| 1/11/2010 14:52:44.000 | Door Grant Access                      | ...   | 1B-Door-2 | /sjc28/gw_FT |
| 1/11/2010 14:52:32.000 | Door Not Used                          | ...   | 1B-Door-2 | /sjc28/gw_FT |
| 1/11/2010 14:52:29.000 | Door Grant Access                      | ...   | 1B-Door-2 | /sjc28/gw_FT |
| 1/11/2010 14:52:17.000 | Door Not Used                          | ...   | 1B-Door-2 | /sjc28/gw_FT |
| 1/11/2010 14:52:14.000 | Door Grant Access                      | ...   | 1B-Door-2 | /sjc28/gw_FT |
| 1/11/2010 14:52:01.000 | Door Not Used                          | ...   | 1B-Door-2 | /sjc28/gw_FT |
| 1/11/2010 14:51:58.000 | Door Grant Access                      | ...   | 1B-Door-2 | /sjc28/gw_FT |
| 1/11/2010 14:51:46.000 | Door Not Used                          | ...   | 1B-Door-2 | /sjc28/gw_FT |
| 1/11/2010 14:51:43.000 | Door Grant Access                      | ...   | 1B-Door-2 | /sjc28/gw_FT |

Alarms: 28 active      500 items      cpamadmin - sjc28

**Note**

Follow the same steps to associate cameras with devices if you have launched a 7X camera driver.

**Tip**

For more information about configuring Cisco VSM cameras, see the [Cisco Video Surveillance Manager User Guide](#).

## PC Workstation Requirements for Live Video Viewing

Table 15-1 describes the recommended baseline configuration for a monitoring workstation that displays video from Cisco Video Surveillance Manager (VSM). A workstation with this configuration was used to determine the recommended maximum video loads. This configuration assumes that the workstation is dedicated to video. Running other software, such as firewalls, antivirus applications, CD/DVD burning utilities, and general-purpose applications will reduce the quality of the user experience.

**Table 15-1** Video Surveillance Monitoring Workstation Recommended Baseline Specification

| Workstation Attribute    | Baseline Specification                              |
|--------------------------|-----------------------------------------------------|
| OS                       | Windows 7 64-bit, SP3                               |
| CPU                      | Intel 950 i7 Core - 3.07 GHz                        |
| Memory                   | 6 GB DDR3                                           |
| Graphics                 | NVIDIA GeForce GTX260 896MB PCIe                    |
| Cisco VSOM configuration | VMR mode enabled                                    |
| Web browser              | Microsoft Internet Explorer 7                       |
| Network connection       | Gigabit Ethernet (GigE) network connection required |
| Display configuration    | Single monitor                                      |

For related information, see the *Video Surveillance Monitoring Workstation Recommended Baseline Specification*, which is available at:

<http://www.cisco.com/c/en/us/support/physical-security/video-surveillance-manager/products-technical-reference-list.html>

## Installing the Cisco VSOM Video Client Desktop Application

The Cisco VSOM Video Client includes the ActiveX controls required for event video viewing. Install the player to enable the video features, or anytime the Cisco VSM server is upgraded. When the player is installed, any existing version is automatically deinstalled.

- 
- Step 1** Verify that all PC workstations meet the [PC Workstation Requirements for Live Video Viewing, page 15-11](#).
  - Step 2** Configure the VSM Camera Driver, as described in [Configuring the Camera Driver, page 15-3](#).
  - Step 3** Select the **VSM Camera Driver** in the Hardware Tree.

Figure 15-1 Hardware Tree ICPAM

The screenshot displays the 'Hardware - Tree - Connected Physical Access Manager' interface. The left pane shows a hierarchical tree structure under 'sjc28'. The 'Cisco VSM Camera Driver [Started]' is selected, and a green arrow points to it. Below it are two areas: 'Cube Area [Online]' and 'Lab Area [Online]', each containing several camera devices. Other drivers listed include 'Access GW Driver', 'EDI Driver', 'Logical Driver', 'CAM-CG Historical Events Driver', and 'CAM-CG Automation Driver'. The right pane shows the 'Status' and 'Extended Status' for the selected driver. A green arrow points to the 'VSOM Video Client(install link)' in the 'Extended Status' section.

| Status   |                          |
|----------|--------------------------|
| Status:  | Started                  |
| Name:    | Cisco VSM Camera Driver  |
| Type:    | Cisco VSM Camera Driver  |
| Model:   |                          |
| Parent:  | Driver Manager localhost |
| Address: | localhost                |
| Enabled: | Yes                      |
| Site:    | sjc28                    |

| Extended Status                  |                                                                                             |
|----------------------------------|---------------------------------------------------------------------------------------------|
| Cisco VSM web link:              | <a href="http://10.194.31.18">http://10.194.31.18</a>                                       |
| VSOM Video Client(install link): | <a href="http://10.194.31.18/vsom/index.php?cmd">http://10.194.31.18/vsom/index.php?cmd</a> |

Alarms: 28 active cpamadmin - sjc28

- Step 4** Click the **VSOM Video Client (install link)** to open the Cisco VSM download page in a Web browser.
- Step 5** Enter the Cisco VSM username and password supplied by your systems administrator.
- Step 6** Click the link for the **VSOM Video Client**.
- Step 7** Follow the on-screen instructions to save the installation file to your local drive.
- Step 8** Double-click the installation file and follow the on-screen prompts to install the VSOM Video Client on your PC.



# Viewing Video

You can view multiple live video streams in a grid arrangement, or view live and archived video for an event. When viewing live video, you can invoke commands for the doors and devices associated with the camera.



**Tip**

---

You can also right-click the cameras listed under the VSM Camera Driver (in the Hardware - Tree module) and select **View Live Video**.

---

This section includes the following instructions:

- [Viewing Live Video in a Grid Arrangement, page 15-14](#)
- [Viewing Video for an Event, page 15-21](#)

## Viewing Live Video in a Grid Arrangement

To view live video in a grid arrangement while using **VSM Camera Driver 7X**, do the following:

- Step 1** Select **Camera Manager 7X** from the **Events & Alarms** menu, in the **Video** submenu.

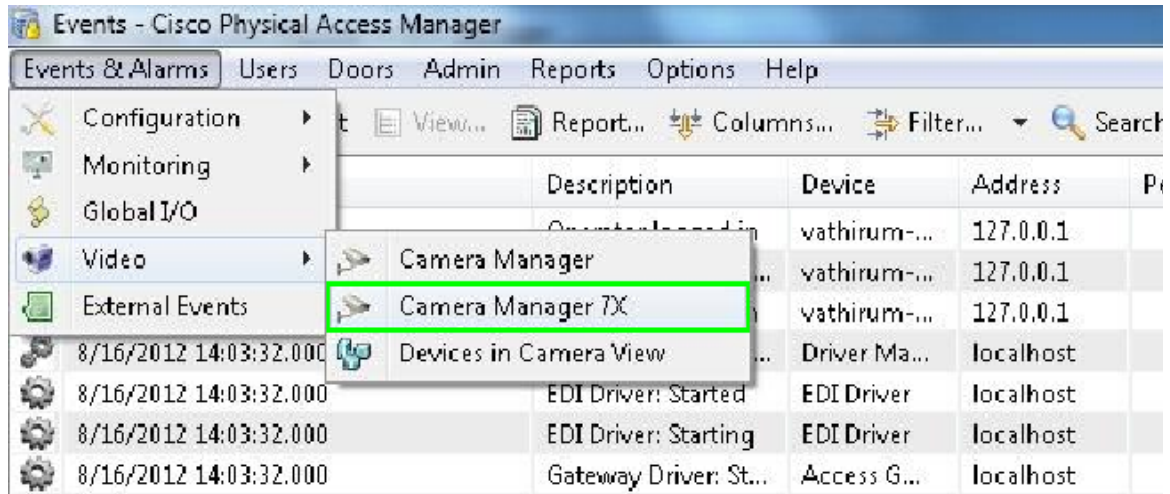

- Step 2** In the resulting window, click the **Layouts** menu and select a layout that includes the number of cameras you want to view.

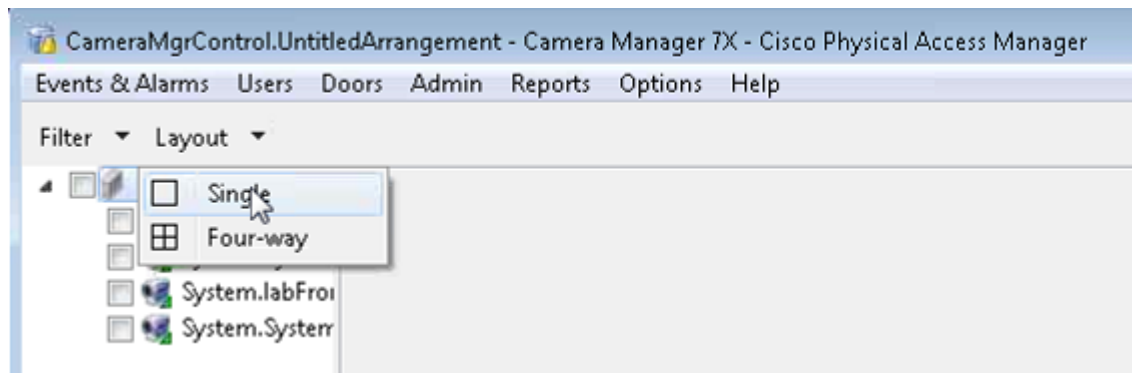

**Step 3** Select the cameras, and then click **SUBMIT** to view the videos of the selected cameras.

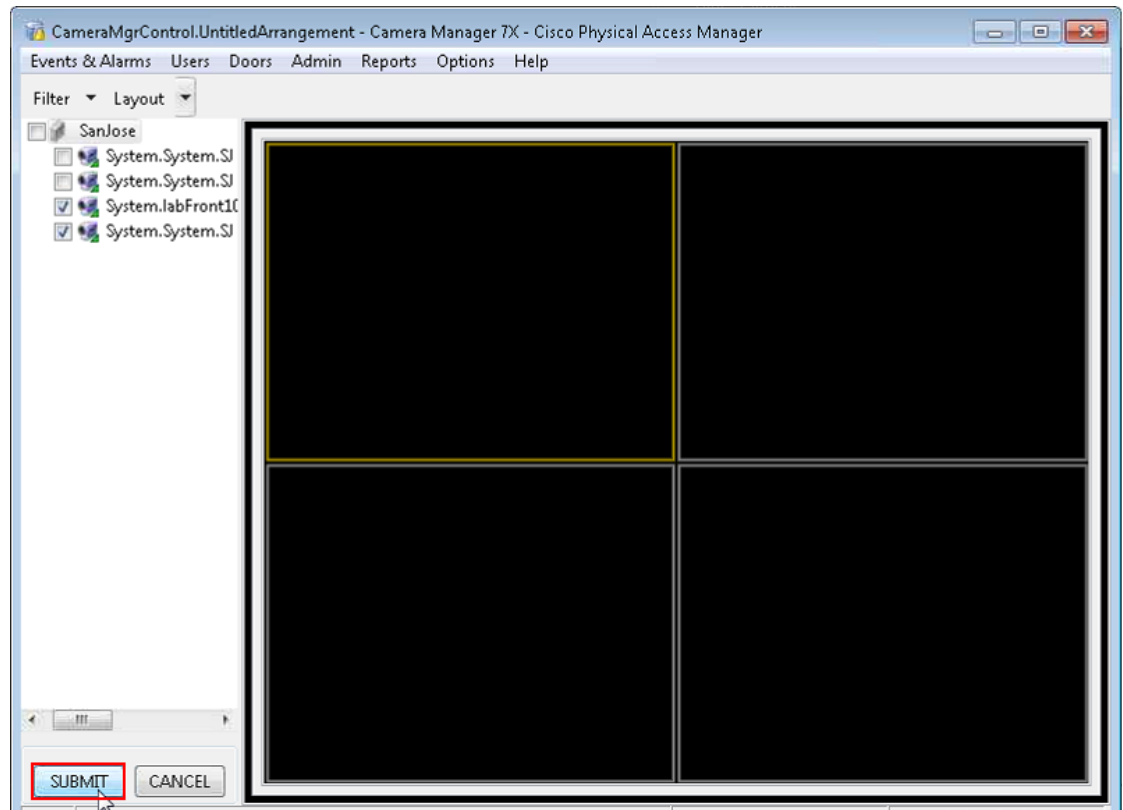
**Note**

Based on the system configuration settings (see [Logins page of the System Configuration window, page 17-11](#)), only cameras that are assigned to your user profile, location, and sub location will be listed for selection.

## Camera Grid Editor

Use the camera grid editor to create multi-frame screens from which to monitor live video. Later, you can recall the created grids to use the camera grid feature as detailed in [Viewing Live Video in a Grid Arrangement, page 15-14](#).

To use the Camera Grid Editor:

- Step 1** Select **Camera Grid Editor** from the **Events & Alarms** menu, in the **Video** submenu.

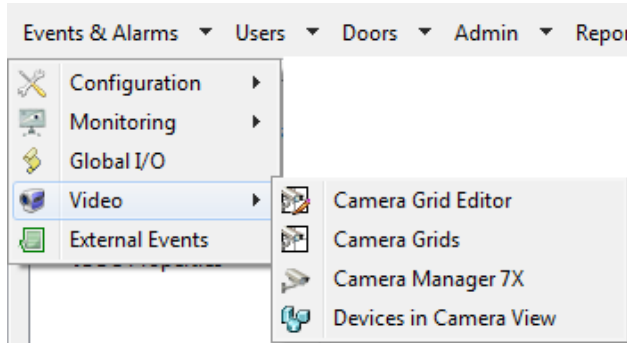

- Step 2** In the resulting Camera Grid dialog, type a name for this new grid, specify the Location where the video for this grid originates, and click **OK**.

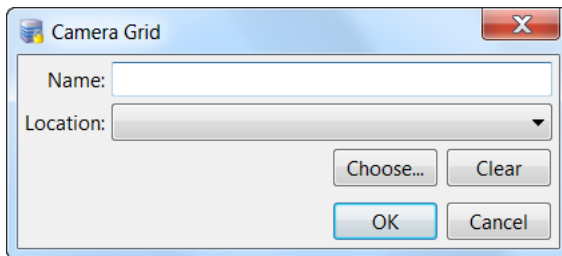

If required, click **Choose...** to browse for the required location.

The Camera Grid Editor for the new grid appears, with the default of four frames.

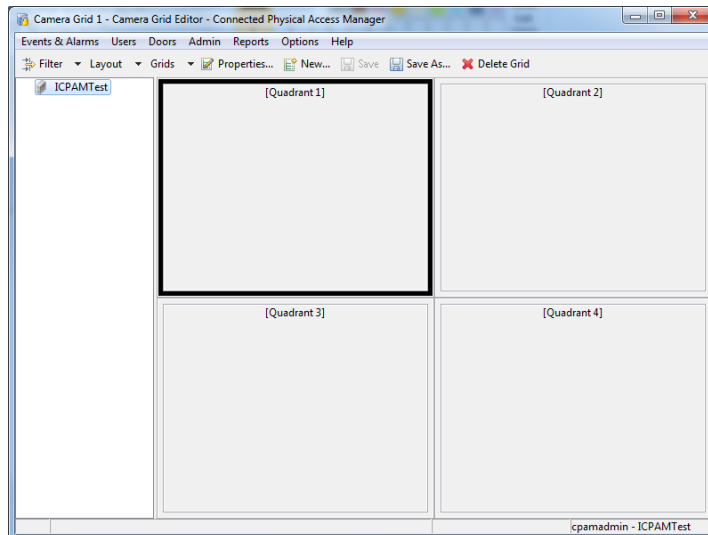

**Step 3** To change the number of frames in this grid, click the **Layouts** menu and select a layout that includes the number of cameras you want to view.

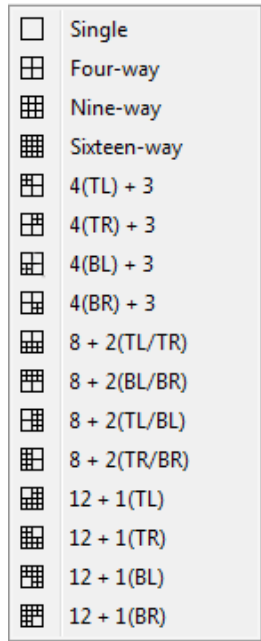

**Step 4** Select the cameras for viewing:

- Expand the hardware tree to locate a camera.
- Drag a camera's icon onto a frame to view live video from that camera.

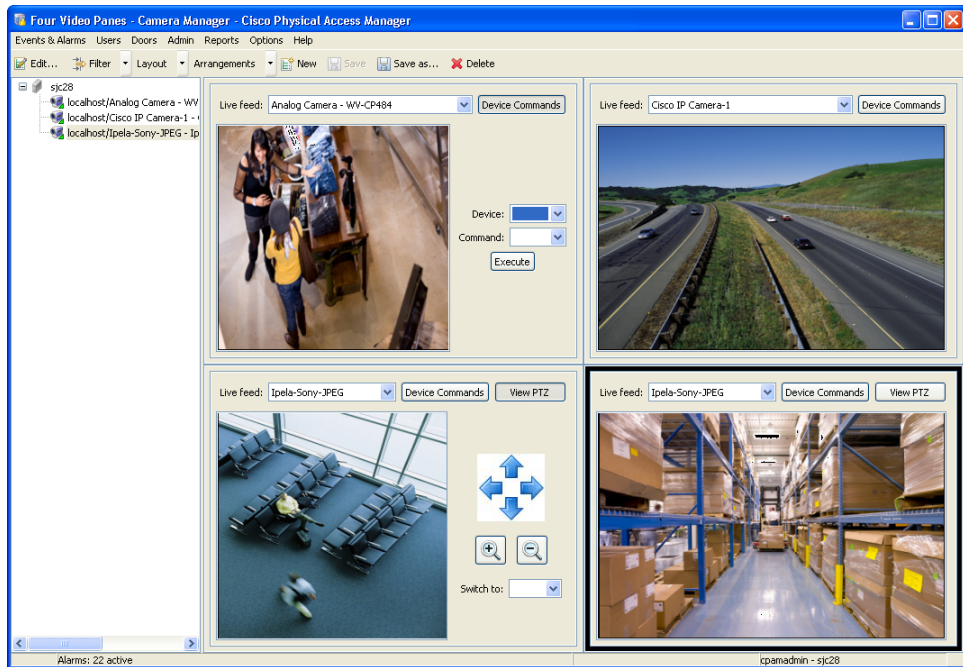

**Tip**

To remove the camera, click and drag the title bar of the camera screen off the grid.

**Step 5** (Optional) Invoke a command for a device associated with a camera.

For example, to deny access to a door.

- a. Click the **Device Commands** button to show (or hide) the command options.
- b. Select a **Device**.
- c. Select a **Command**.



**Tip** The commands are also available by right-clicking the camera name in the Hardware - Tree module.

- d. Click **Execute**.
- e. If additional options are available, select an option from the pop-up window and click **OK**.

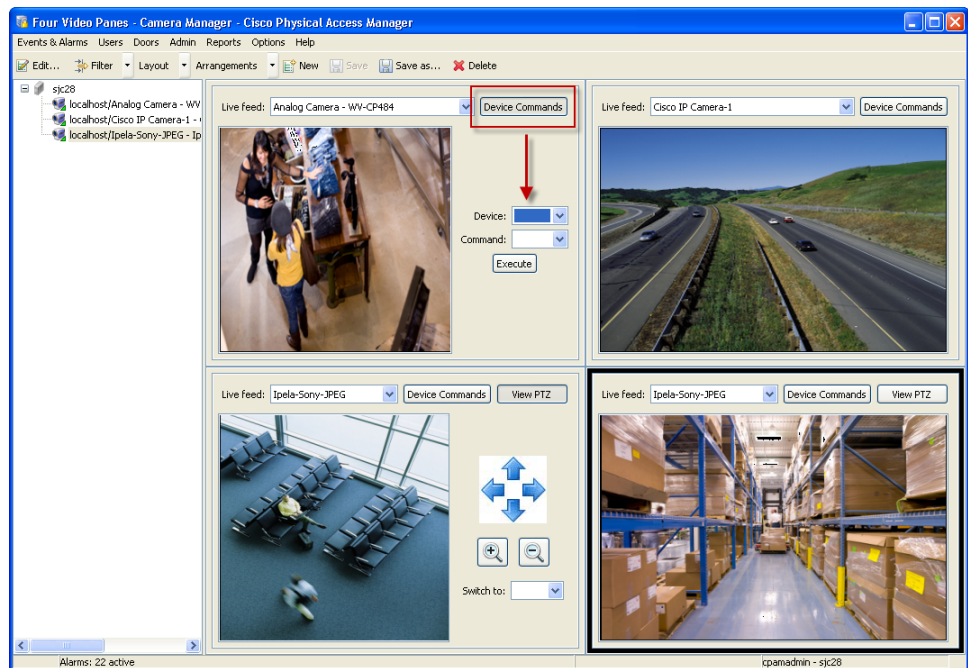

**Step 6** (Optional) Operate the pan, tilt, and zoom (PTZ) camera controls, if available.

- Click **View PTZ** to show (or hide) the controls. This option only appears for PTZ cameras.
- Use the arrows to pan and tilt the camera view. Use + and - to zoom.

- Select a PTZ preset from the **Switch** to drop-down menu.

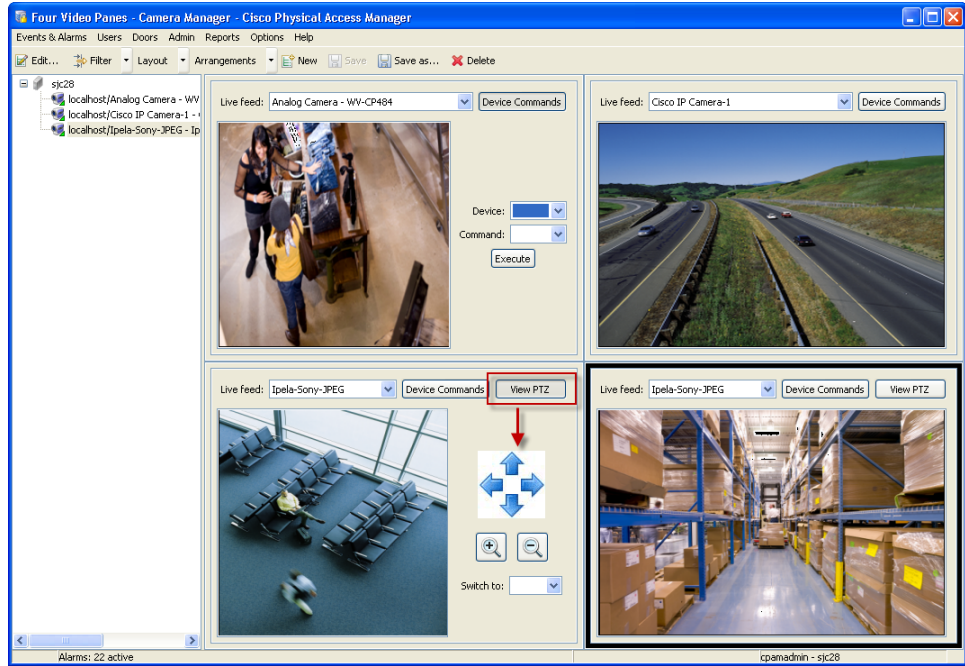

- Step 7** (Optional) Save the camera view as an *Arrangement*.
- Click **Save** or **Save As** to save the current camera layout as an **Arrangement**.
  - Type the arrangement name and click **OK**. The layout name appears in the window title bar.

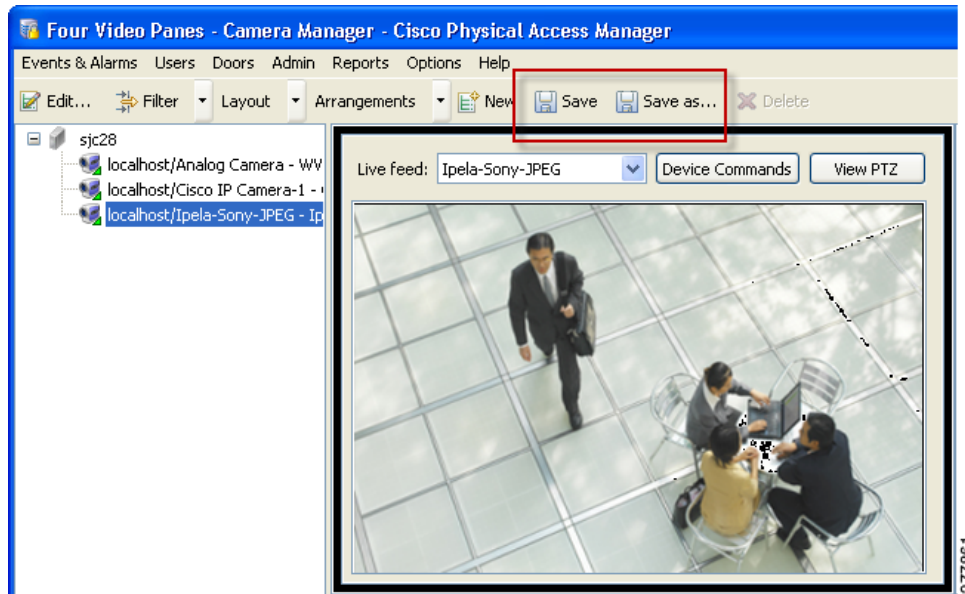

**Step 8** (Optional) Create or modify additional arrangements using the menu bar controls:

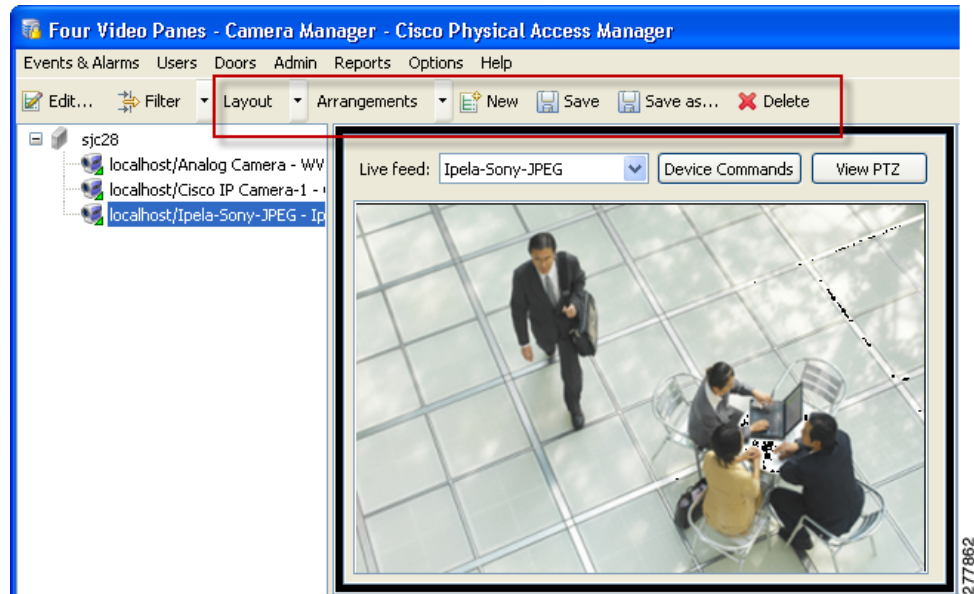

- **Layout:** selects a blank layout to display video from one or more cameras.
- **Grids:** selects one of the existing grids.
- **Properties:** change the definition of the currently selected grid.
- **New:** creates a new screen of views and cameras.
- **Save:** saves the current view as an Arrangement.
- **Save As:** saves the Arrangement under a different name.
- **Delete:** deletes the current layout.



## Viewing Video for an Event

If a device or door is associated with a camera, and an event occurs for that device, you can view archive video for the event (if an archive feed has been configured for the camera). To define how much video to display before and after events occur, see the “[Defining the Duration of Event Video Recording](#)” section on page 15-25. For example, video event archives can begin 30 seconds before the event occurred, and continue 20 seconds after the event occurred. If the archive is not available, an error message appears (for example, if the event video occurred previous to the archive window).

You can also view live video from the camera that captured the event.

Event video includes the following options:

- **View Live Video**—view live video from the camera associated with the event.
- **View Event Video**—view the video archive for the event.
- **View Live and Event Video**—open both live and archive video windows.
- **Show Camera Arrangement**— displays all camera arrangements that include the camera associated with the event. If the camera is not included in any camera arrangements, then this option is disabled (grayed out).

### Usage Notes

- In the Events main window, you can display a Video column to indicate whether a camera is associated with a door or device. Click **Columns** in the toolbar, select **Video**, and click **OK**. The Video column displays three dots if a camera is associated with the door or device. To ensure the dots appear correctly, you must exit and relaunch the ICPAM client after associating cameras with a device or door.
- Beginning with CPAM release 1.3.0, you can assign cameras to a location. The camera location enables you to configure event policies for a group of cameras based on location. For example, you can suppress event and alarm notifications of motion events from cameras in a high traffic area during normal business hours. To assign a location to a camera:
  - Select **Camera Manager** from the **Events & Alarms** menu, in the **Video** submenu.
  - Right-click a camera name.
  - Click the **Location** tab.
  - Select a location from the Hierarchical Location menu.
  - Click **Save and Close**.



### Tip

---

You can also edit the camera location using the Hardware - Tree module. Right-click a camera name and choose **Edit**. Select the Location tab and choose a Hierarchical Location from the drop-down menu.

---

## Viewing Event Video on a VSM Camera Driver 7X

To view events on a VSM Camera Driver 7X, do the following procedure.

- Step 1** From the hardware tree view, right-click the VSM camera and select **View Live Video**.

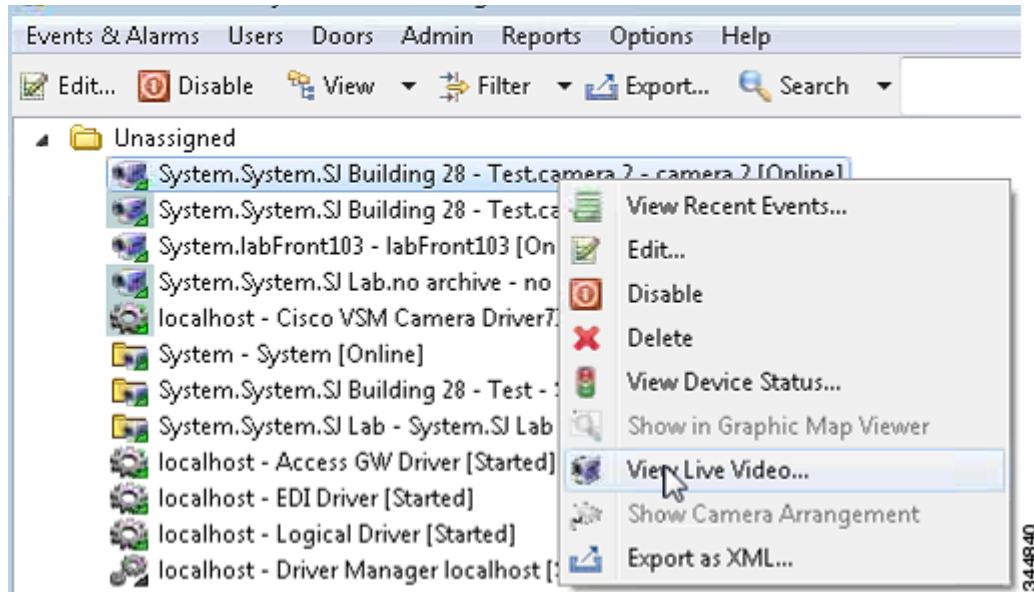

The live video window opens.



Alternatively you can also view Live video from **Events and Alarms->Monitoring->Events** and click any camera event.

Select a video option from the right-click menu:

- a. Right-click an event or alarm entry.
- b. Select a camera from the command menu.

- c. Select a view option:
  - **View Live Video**—view live video from the camera associated with the event.
  - **View Event Video**—view the video archive for the event.
  - **View Live and Event Video**—open both live and archive video windows.
  - **Show Camera Arrangement**—displays all camera arrangements that include the camera associated with the event. If the camera is not included in any camera arrangements, then this option is disabled (grayed out).

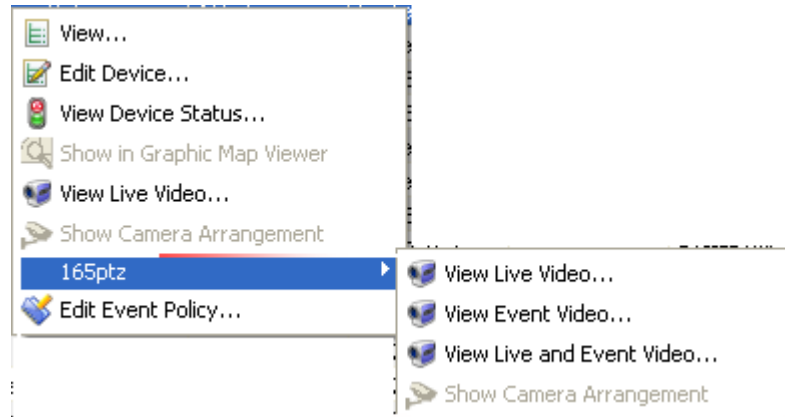

**Tip** The video and camera options appear only if video is available for that event.

- Step 2** (Optional) You can also select the video options from the event detail window.
- a. Double-click an event or alarm entry.

- b. In the detail window, click a viewing option: **Live Video**, **Event Video**, **Live and Event Video**, or **Arrangement**.

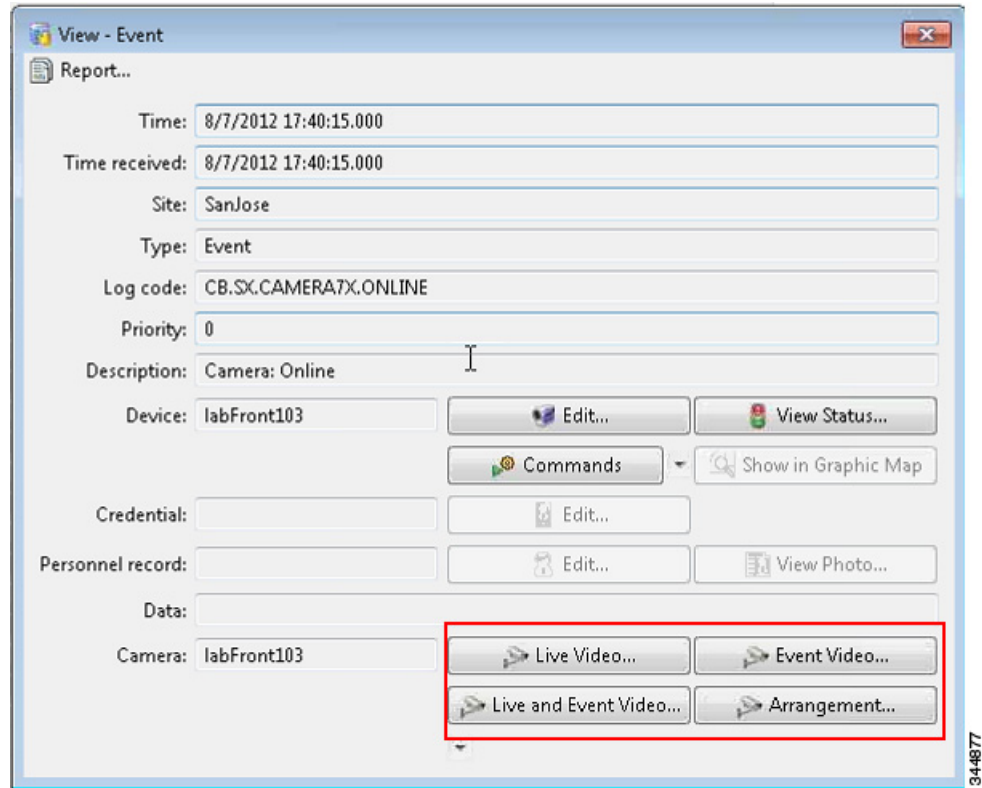

**Tip**

The video and camera options appear only if video is available for that event.

- Step 3** When viewing recorded event video, use the controls under the video display to fast forward, rewind, pause, or play the clip.

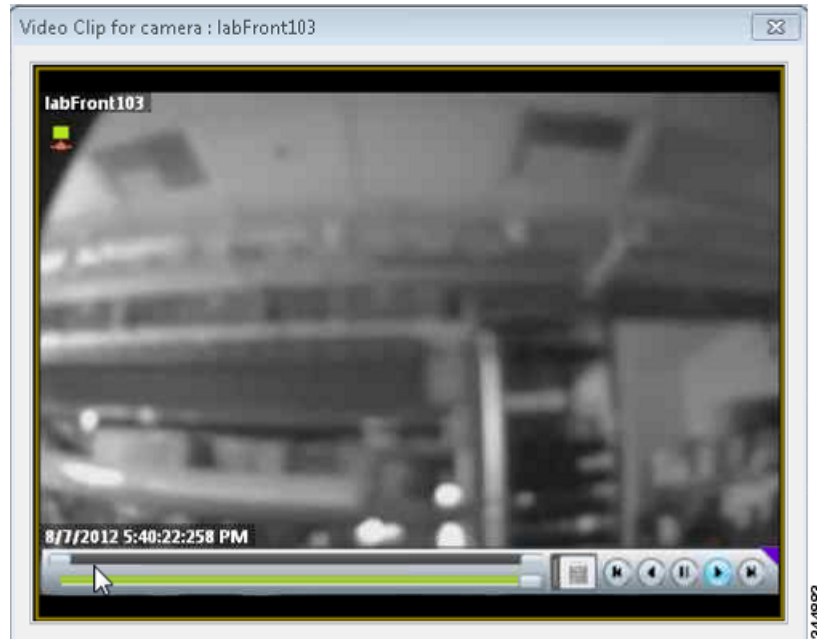

**Tip** Press the Rewind or Forward buttons multiple times to increase the speed. You can playback or rewind video at 1x, 2x, 3x, or 4x.

If this is an event video, a time bar is displayed.

## Defining the Duration of Event Video Recording

By default, event video is recorded for 5 seconds before the event occurs, and 5 seconds after the event occurs. To change the number of seconds that event video is recorded, do the following:

- Step 1** Choose the **Admin > System Configuration** command.
- Step 2** On the resulting window, click the **Events/Alarms** tab.

Figure 15-2 System Configuration window - Events/Alarms page

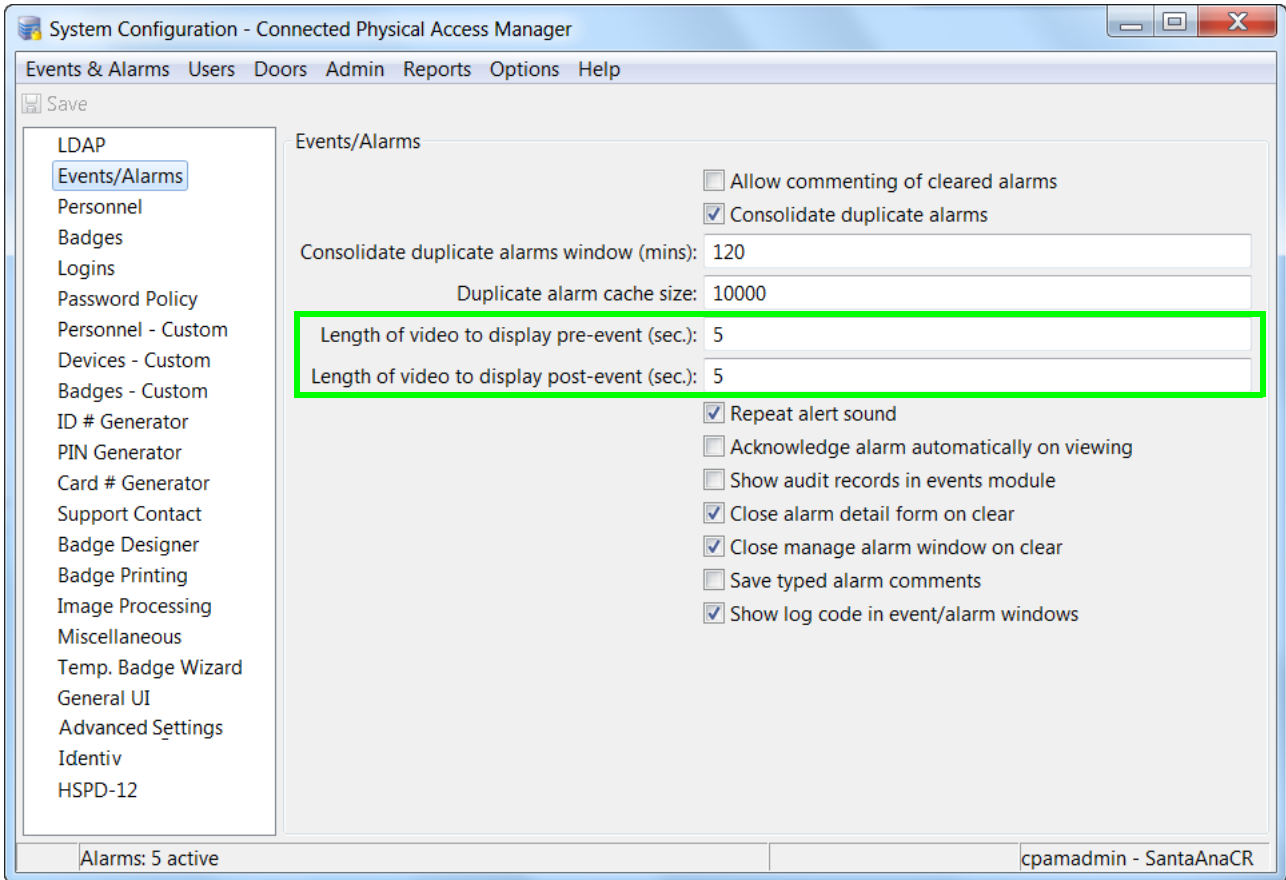

**Step 3** Enter the following:

*Table 15-2*

|                                              |                                                                             |
|----------------------------------------------|-----------------------------------------------------------------------------|
| <b>Length of video to display pre-event</b>  | The number of seconds of video that are included before the event occurred. |
| <b>Length of video to display post-event</b> | The number of seconds of video that are included after an event occurred.   |

**Step 4** Click **Save**.

**Step 5** Log out (select **Logout** from the **Options** menu) and log back in to the ICPAM application to activate the changes.

# Managing the Camera Inventory

- [Updating the Camera Inventory, page 15-27](#)
- [Deleting the Cisco VSM Cameras, page 15-29](#)
- [Deleting Individual Cameras, page 15-33](#)

## Updating the Camera Inventory

The list of available Cisco VSM cameras is automatically updated as cameras are added or removed from the Cisco VSM system. In most situations, users do not need to update or manage the camera inventory. However, if the camera list is not accurate, do one of the following, in the order shown:



### Tip

- Entering the **Restart**, **Setup VSOM**, or **Synchronize with Cisco VSM** commands will retrieve the camera inventory, regardless of the configured run frequency. It may take up to a minute to synchronize the inventory. After the initial synchronization, the inventory is updated based on the scheduled run frequency.
- If a camera is deleted from the Cisco VSM configuration, it is disabled in ICPAM, but not removed. We recommend that you do not manually remove or delete cameras from the ICPAM configuration. Use the **Synchronize with Cisco VSM** command to update the camera inventory.

**Step 1** Revise the time span between automatic synchronizations:

- Right-click the **Cisco VSM Camera Driver** and select **Setup Cisco VSM**.

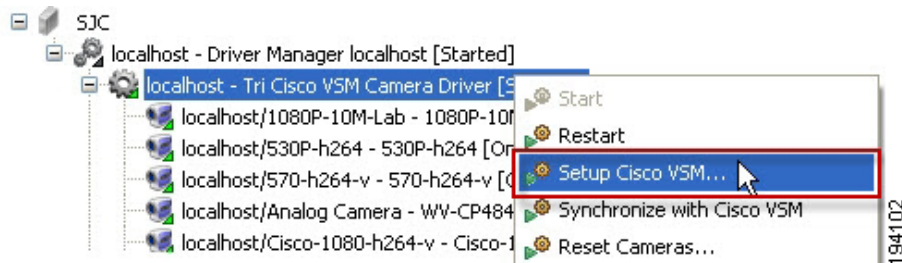

- Enter the **Run Frequency (in minutes)**: this defines the time between synchronizations. Cameras added or removed from Cisco VSM are updated in ICPAM. If the camera inventory changes often, enter a low number. If the inventory changes rarely, enter a high number. The default is 30 minutes.

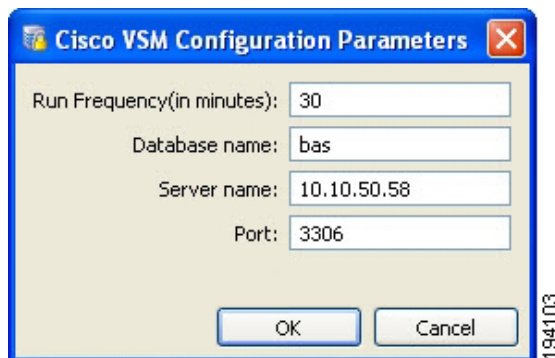

- c. Click **OK** to save the changes and close the window.



**Tip** These fields are disabled if the camera driver was previously set up and includes cameras.

- Step 2** Right-click the **Cisco VSM Camera Driver** and select **Synchronize with Cisco VSM**.

This command manually synchronizes ICPAM with the Cisco VSM inventory.

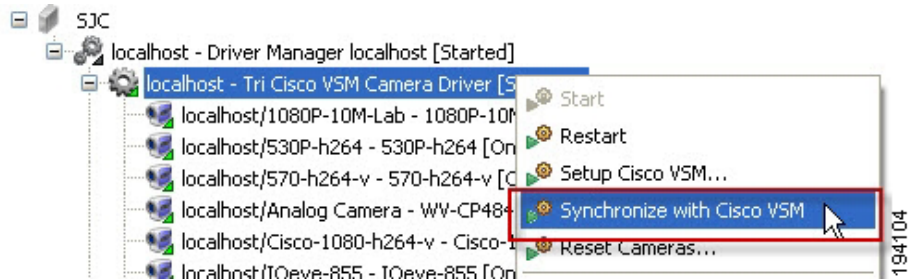

- Step 3** If the camera inventory is still not correct, restart the camera driver: right-click the **Cisco VSM Camera Driver** and select **Restart**.

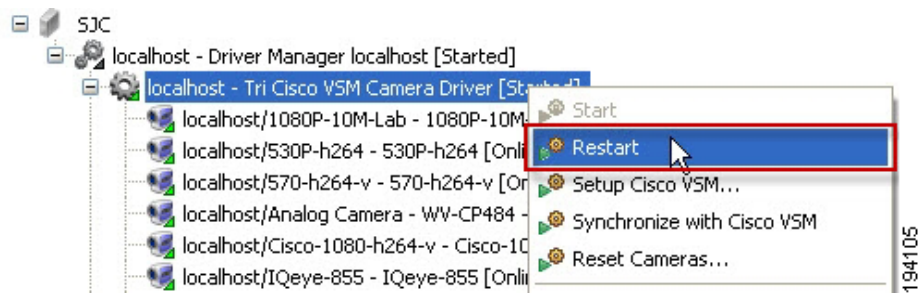

- Step 4** Verify that the driver reset was successful.
- Select **Alarms** from the **Events & Alarms** menu, in the **Monitoring** menu.
  - Verify that the following three events are listed as successful:
    - *archive data feed*
    - *live data feed*
    - *camera data feed*

- Step 5** If the camera list is still not accurate, continue to the following section: [Deleting the Cisco VSM Cameras](#).



## Deleting the Cisco VSM Cameras

In some situations (such as following a Cisco VSM server change), the camera inventory may need to be deleted. This is necessary only if the camera listing remains incorrect after completing the instructions in [Updating the Camera Inventory, page 15-27](#).

If problems remain, select the camera driver command to **Delete All Cameras**. This command deletes the ICPAM cameras and downloads a new, updated list from the Cisco VSM server.

Deleting the cameras does the following in ICPAM.

- Removes the Cisco VSM server configuration.
- Removes the history of all cameras from the ICPAM database.
- Deletes all events and audit records for the cameras.
- Deletes the entire camera inventory.



### Note

To successfully reset the camera database, you must remove all camera associations in the Camera Manager and Graphic Maps, as described in the following instructions.

To delete all cameras from ICPAM and reload the camera inventory from the Cisco VSM server, do the following:

- Step 1** Remove all camera references from the Camera Manager layout arrangements, and from any Graphic Map.
- Select **Camera Manager** from the **Events & Alarms** menu, in the **Video** submenu.

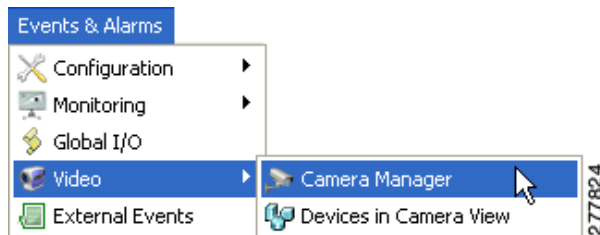

- Select each arrangement, then click on the title bar of each camera, and drag it off the grid.



### Tip

You can also delete the arrangement to remove the camera references.

- Click **Save**.

- d. Select **Map Editor** from the **Admin** menu.

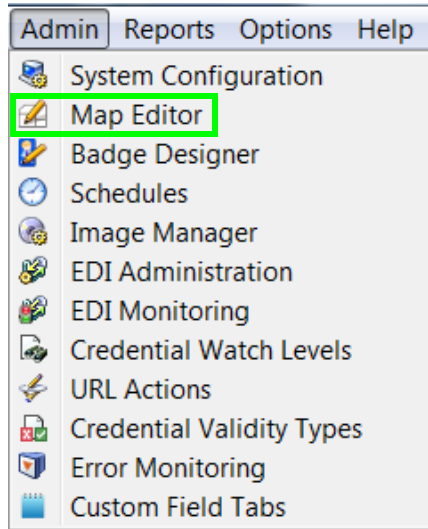

- e. Select any maps that include cameras.  
 f. Right-click each camera icon and select **Remove Device Icon**.



**Tip** You can also delete the entire map to remove the camera references.

- g. Click **Save**.

For more information, see the following:

- [Viewing Live Video in a Grid Arrangement, page 15-14.](#)
- [Map Editor, page 12-55.](#)

**Step 2** Do the following:

- a. Enable the **Delete All Cameras** command and the **Allow deletion of devices with events** option in the System Configuration settings.
  - The **Delete All Cameras** command only appears after you enable it in the System Configuration window.
  - The **Delete All Cameras** command will fail to complete if you do not enable the **Allow deletion of devices with events** option.
- b. Select **System Configuration** from the **Admin** menu.
- c. In the resulting window, switch to the **ICPAM Settings** page, and select the check-box for **Display Delete All Cameras command on the camera driver**.
- d. Switch to the **Miscellaneous** page, and select the check-box for **Allow deletion of devices with events**. This allows cameras with associated events to be deleted from ICPAM.
- e. Click **Save**.
- f. To activate the changes, stop and then restart the ICPAM server. See [Using the Web Admin Menus, Commands, and Options, page 2-19](#) for instructions.

**Step 3** Delete the cameras from ICPAM:

- a. Open the Hardware - Tree module.

- b. Right-click on the Cisco VSM camera driver, and select the **Delete All Cameras** command.
- c. Click **OK** when the warning message appears. All events, alarms, and audit messages for the cameras will be deleted.

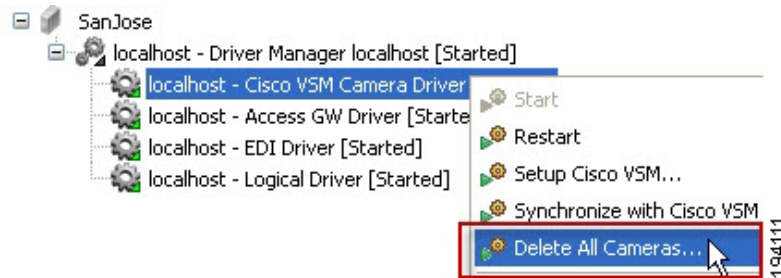

**Step 4** Verify that the deletion was successful.

- If the action succeeds, all cameras are removed from the camera driver. An event is displayed: “Cisco VSM Camera Driver command Succeeded: Reset Cameras”. Continue to substep **d**.
- If the action fails, some cameras are still displayed under the camera driver. If this occurs, do the following:
  - a. View the event *Description* and *Data* fields to locate the issue.
    - The event is: “Cisco VSM Camera Driver command failed: Reset Cameras”.
    - Open the event to view the event *Data* and identify the camera(s).
 For example:  
 “References found; Analog Camera - WV-CP484- s: Graphic Maps: map1-256map5-2.6MB,B10-3, map4,B28-1, Analog Camera - WV-CP484- Camera Arrangements: one.”

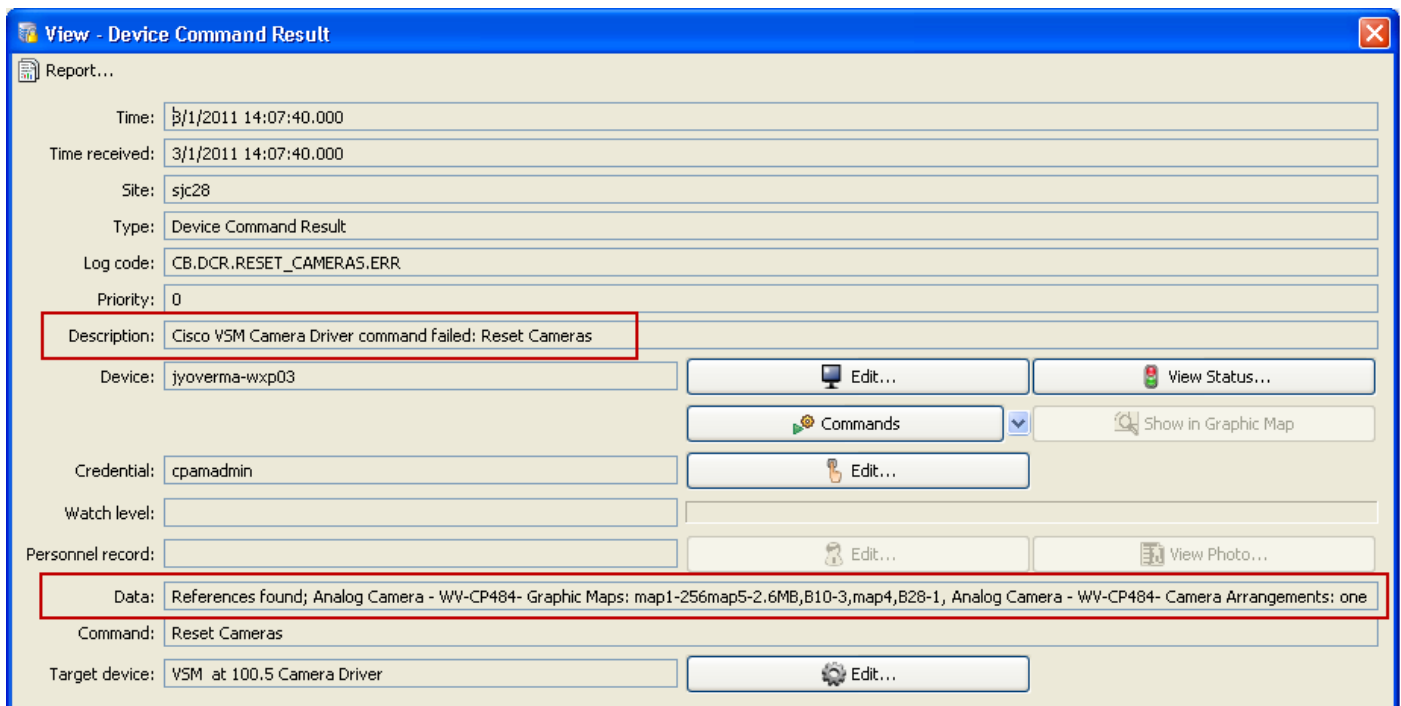

- b. Locate and delete the remaining camera references from Camera Manager and the graphic maps (see [Step 1](#)).

- c. Restart the camera driver to restore the full camera inventory (right-click the **Cisco VSM Camera Driver** and select **Restart**). The **Delete All Cameras** command only works when the complete inventory is present.
- d. Invoke the **Delete All Cameras** command again, as described in substep f.

**Step 5** After the **Delete Cameras** command is successful, restart the camera driver: right-click the **Cisco VSM Camera Driver** and select **Restart**.

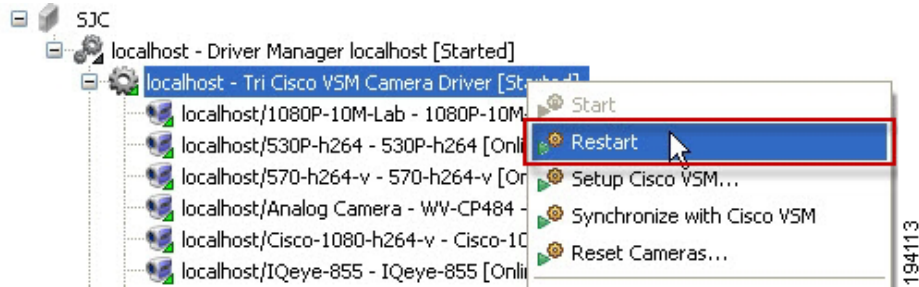

**Step 6** Verify that the driver reset was successful.

- a. Select **Alarms** from the **Events & Alarms** menu, in the **Monitoring** menu.
- b. Verify that the following three events are listed as succeeded:
  - *archive data feed*
  - *live data feed*
  - *camera data feed*

**Step 7** Re-enter the Cisco VSM server settings:



**Note** Do not change the database name or port number after they have been configured.

- a. Right-click the **Cisco VSM Camera Driver** and select **Setup Cisco VSM**.

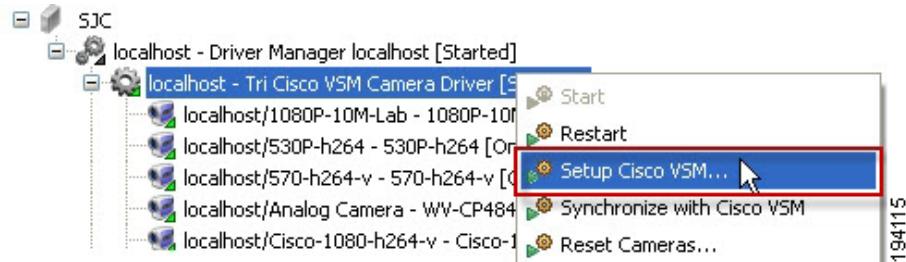

In the resulting dialog:

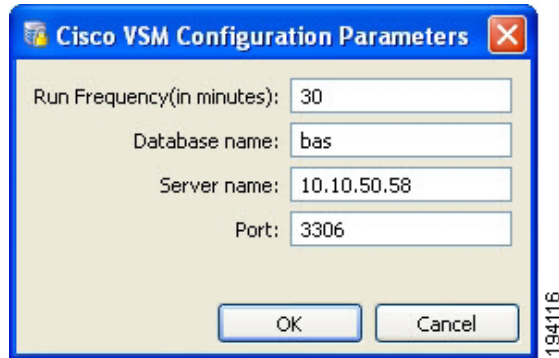

- b. Type the **Run Frequency (in minutes)**: the time between ICPAM / VSM synchronizations. Cameras added or removed from Cisco VSM are updated in ICPAM. If the camera inventory changes often, enter a low number. If the inventory changes rarely, enter a high number. The default is 30 minutes.
- c. Type the **Database name**: the name of the Cisco VSM database. The default is `bas`.
- d. Type the **Server name**: the name or IP Address of the Cisco VSM database server.
- e. Type the **Port number**: the port number for the Cisco VSM database server.
- f. Click **OK** to save the changes and close this dialog.



**Tip** Entering the **Restart**, **Setup VSOM**, or **Synchronize with Cisco VSM** commands will retrieve the camera inventory immediately, regardless of the configured run frequency. After the initial synchronization, the inventory is updated based on the scheduled run frequency.

## Deleting Individual Cameras

To delete individual cameras, do the following:



**Tip** See [Deleting the Cisco VSM Cameras, page 15-29](#) for information about a command to delete all cameras.

- Step 1** Remove the camera associations (for the camera to be deleted) from the Camera Manager arrangements, and from any Graphic Map.



**Tip** You can also delete the entire camera arrangement or graphic map to remove the associations.

- Step 2** Enable the **Allow deletion of devices with events** option in the System Configuration settings.
  - a. On the System Configuration window, switch to the **Miscellaneous** page, and select the check-box for **Allow deletion of devices with events**. This allows cameras with associated events to be deleted from ICPAM.

b. Log out (select Logout from the Options menu) and log back in to the ICPAM application to activate the changes.

**Step 3** (Optional) Right click the camera and select **Disable**. Cameras that were removed from Cisco VSM server are disabled by default. This command is only necessary if you want to remove a camera that is included in the Cisco VSM server inventory.

**Step 4** Select **All Devices** from the **Filter** menu to display the disabled device.

**Step 5** Right click the camera and select **Delete**.



---

**Tip** If the camera is still associated with Camera Manager arrangements or graphic maps, an error message describes the location of the associations. Remove the associations and issue the **Delete** command again.

---

**Step 6** Click **OK** to confirm that all associated events will be deleted.



---

**Note** See [Disabling or Deleting a Door, page 7-16](#) for more information.

---

---

# Recording Motion Events from Cisco VSM Cameras

This section includes instructions to record start motion and stop motion events for Cisco VSM cameras in ICPAM. When a motion event occurs, the system can optionally open a video pop-up window.



## Tip

See the [Cisco Video Surveillance Manager User Guide](#) for more information.

## Procedure

**Step 1** Configure the **Camera Driver** as described in [Configuring the Camera Driver, page 15-3](#).

Skip to [Step 2](#) if the camera driver is already configured.

**Step 2** Verify that ICPAM Web Services are enabled:



## Note

Skip to [Step 3](#) if ICPAM Web Services are already enabled.

- a. Log on to the ICPAM Server Administration utility, as described in the “[Logging on to the ICPAM Server Administration Utility](#)” section on page 2-2.
- b. Select the **Monitoring** tab, and then select **Status**.



## Note

The Status window appears by default. This window also appears when you first log on.

- c. Verify that the **Web Service API** service is *Enabled* ([Figure 15-3](#)).

**Figure 15-3** Web Services API Status

The screenshot shows the ICPAM Server Administration web interface. The top navigation bar includes 'Monitoring', 'Setup', 'Commands', 'Launch Identiv Client', and 'Downloads'. The 'Monitoring' tab is selected, and the 'Status' page is displayed. The 'Server' section shows the following details:

|                          |              |      |
|--------------------------|--------------|------|
| Admin State:             | Up           | Stop |
| Server Mode:             | Active       |      |
| Version:                 | 2.0.0        |      |
| Serial Number:           | 000C29200881 |      |
| High Availability Audit: | disabled     |      |

The 'Services' section shows the following details:

|                 |         |         |
|-----------------|---------|---------|
| TFTP Service    | Up      | Stop    |
| Web Service API | Enabled | Disable |

The 'Web Service API' row is highlighted with a green border. A 'Cisco Compatible' logo is visible in the bottom right corner. The footer contains the text: 'Copyright © 2015 Identiv, Inc. | All Rights Reserved.'

- Step 3** (Optional) To open a video pop-up window for door events, associate a door with the camera:
- a. In the **Devices in Camera View** window, expand the tree to display the configured doors, as shown in [Figure 15-4](#).

*Figure 15-4 Devices in Camera View: Door to Camera Association*

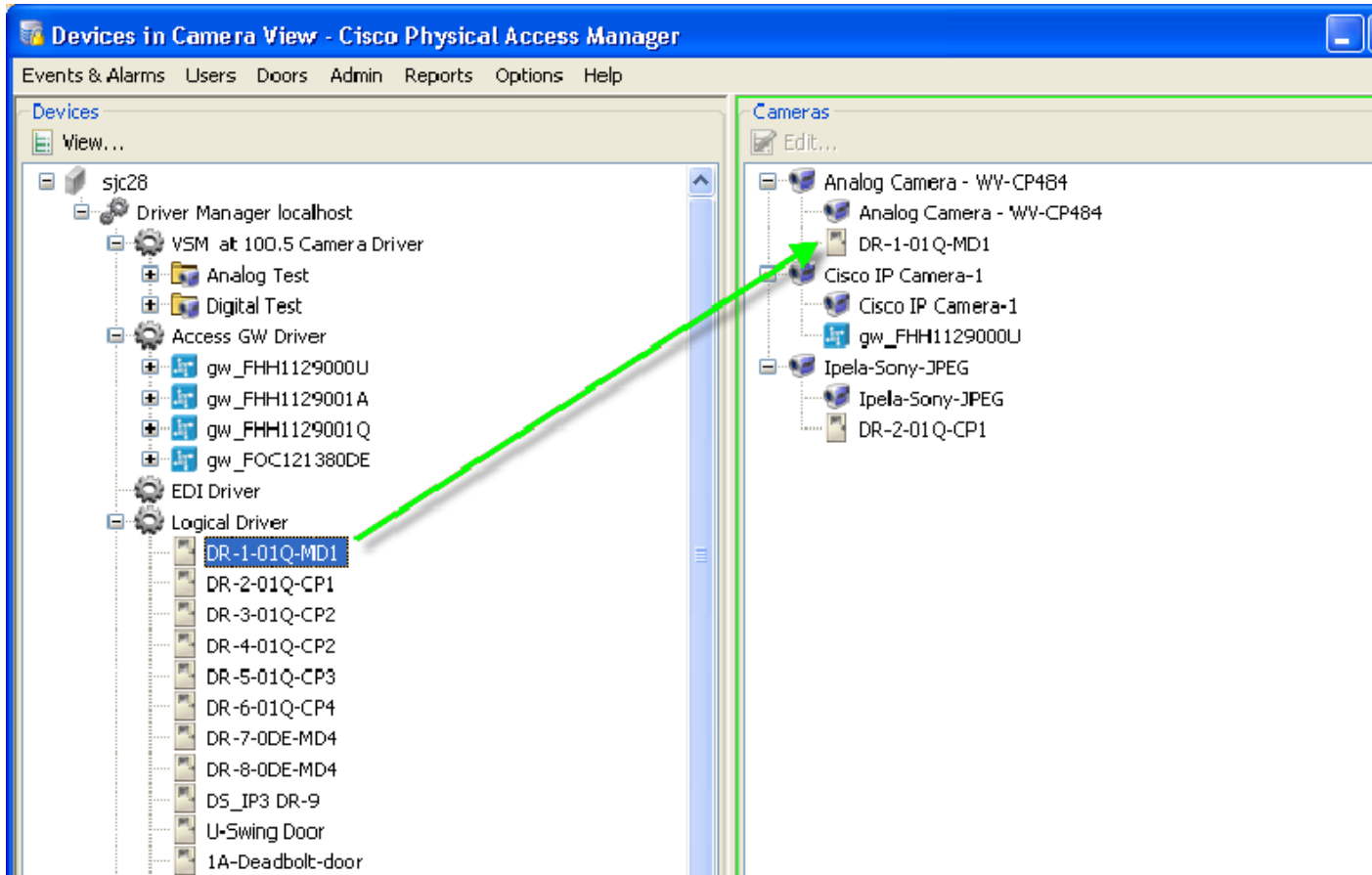

- b. Drag a door from the *Devices* left pane and drop it on a camera in the *Cameras* right pane. The door is displayed as a child of the camera.

- Step 4** Identify and record the Camera ID, as shown in [Figure 15-5](#). The Camera ID is used in the URL used to call the event, as described in [Step 5](#).



Figure 15-5 Locating the Camera ID

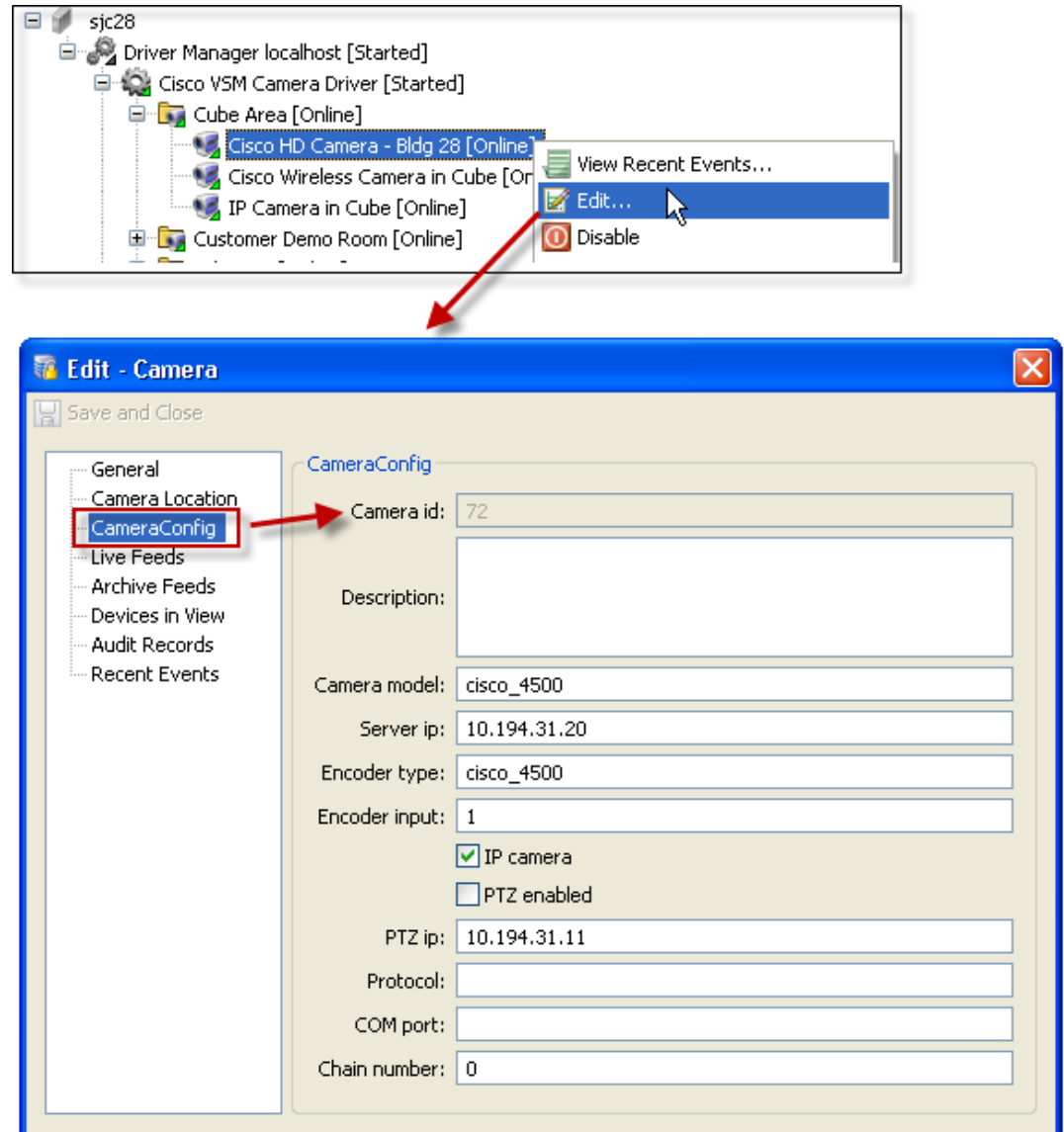

- a. Select **Hardware - Tree** from the **Doors** menu.
- b. Expand the **Camera Driver** to display the available cameras.
- c. Right-click a camera and select **Edit** from the pop-up menu.
- d. In the resulting dialog, switch to the **CameraConfig** tab.
- e. Record the number displayed in the **Camera ID** field.

**Step 5** Add a URL Notification to the motion event, using the Cisco VSOM Web-based software.



**Note** Only Cisco VSM events configured with URL notifications are sent to ICPAM.

- a. Use a PC to log in to the Cisco VSOM Web-based software:
  - Start Internet Explorer.
  - Enter the IP address or the host name of the server that is running Cisco VSOM.
  - Enter your username and password.
  - Click **OK**.

The VSOM Operator page appears (see [Figure 15-6](#)).

**Figure 15-6** Enable URL Notification in the Cisco VSOM Events Configuration Page

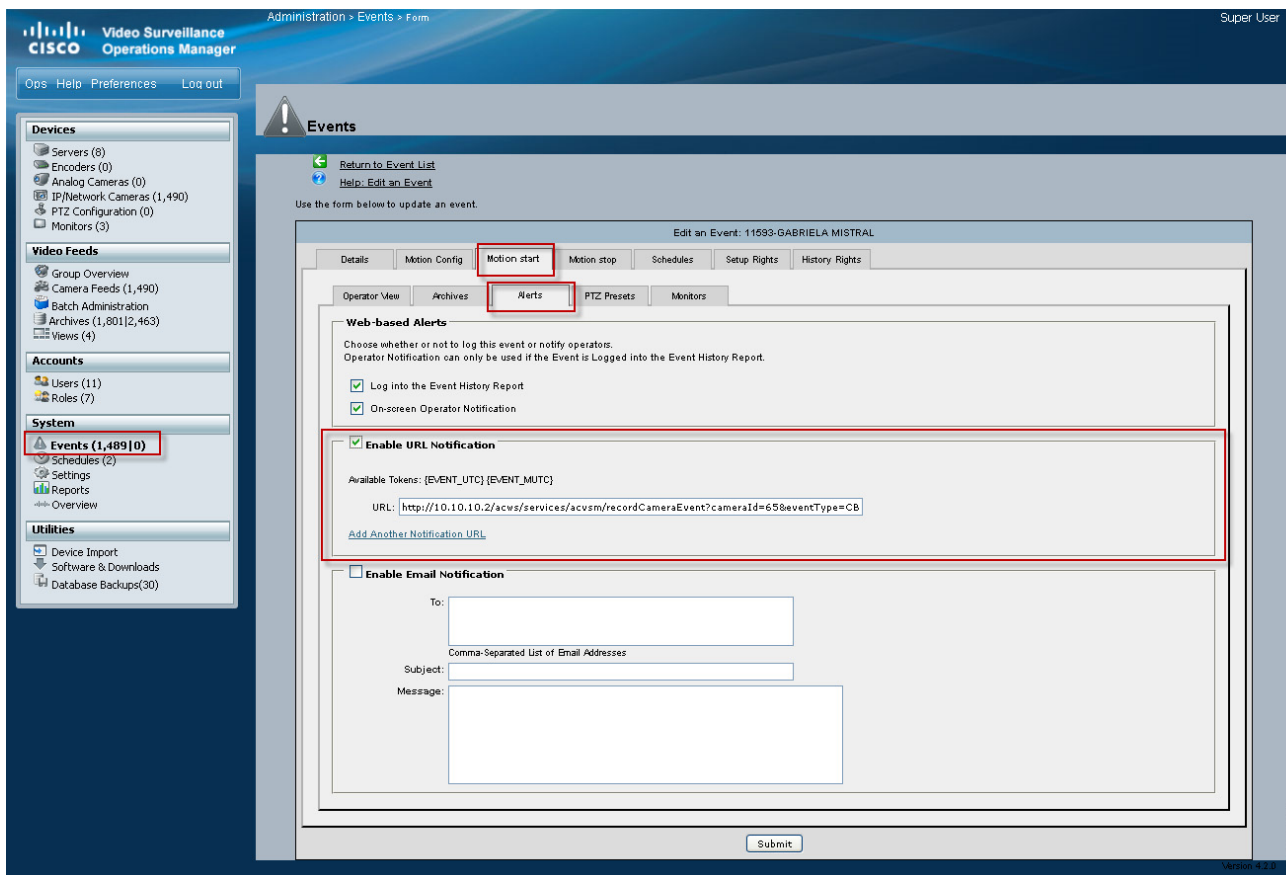

- b. Click **Admin** to open the Administrator pages.
- c. Click **Event** to open the event configuration page.
- d. Create a new motion event, or edit an existing event, as described in the “System Management” chapter of the [Cisco Video Surveillance Manager User Guide](#).
- e. Select the **Motion Start** or **Motion Stop** tab for the event.
- f. Select the **Alerts** tab.
- g. Select the **Enable URL Notification** check box.

- h. Enter the ICPAM URL for the motion event in the following format:

```
http://icpam-ip-addr/acws/services/acvsm/
recordCameraEvent?cameraId=number&eventType=type&eventTime=time_value
```

The URL includes the following parameters:

- *icpam-ip-addr*: the IP address of the ICPAM server.
- *number*: the **cameraId** number recorded in [Step 4](#). For example: 65.
- *type*: the **eventType**. For example: CB.MOTION\_START or CB.MOTION\_STOP
- *time\_value*: the **eventTime**. Enter a timestamp or 0 for the current time.

In the following example, the Camera ID is 65, the Event Type records motion Start events, and the Event Time is “0”. An event time of “0” records events for the current time.

```
http://10.10.10.2/acws/services/acvsm/recordCameraEvent?cameraId=65&eventType=CB.
MOTION_START&eventTime=0
```

- i. Click **Submit** to save the changes.

**Step 6** View the motion events in ICPAM Events:

- a. Launch the ICPAM software and log in, if necessary.
- b. Select **Events** from the **Events & Alarms** menu, under the **Monitoring** submenu.
- c. Sort or search for the event, as described in the [“Viewing Events” section on page 12-3](#).

[Figure 15-7](#) shows an example of a **Camera Motion Start** event. Double-click the event entry for additional details.

**Figure 15-7** Camera Events in ICPAM

| Time                   | Description              | Device                  | Address                        | Data               | Creden... |
|------------------------|--------------------------|-------------------------|--------------------------------|--------------------|-----------|
| 1/28/2010 14:13:51.450 | Camera Motion Start      | Axis 211A Rekha Cube    | localhost/Axis 211A Rekha C... | CB.MOTION_START    |           |
| 1/28/2010 14:00:30.000 | Workstation: Logged In   | vdashora-wxp01          | 127.0.0.1                      |                    |           |
| 1/28/2010 14:00:30.000 | Operator logged in       | vdashora-wxp01          | 127.0.0.1                      | Ch00wW6aTWiJldJ... | cpama...  |
| 1/28/2010 13:55:57.000 | Driver Manager: Started  | Driver Manager local... | localhost                      |                    |           |
| 1/28/2010 13:55:57.000 | Gateway Driver: Started  | Access GW Driver        | localhost                      |                    |           |
| 1/28/2010 13:55:56.000 | Gateway Driver: Starting | Access GW Driver        | localhost                      |                    |           |
| 1/28/2010 13:55:56.000 | Logical Driver: Started  | Logical Driver          | localhost                      |                    |           |

216 items cpamadmin - SanJose

# Triggering Camera Actions and Video Recording in Cisco VSM

Events in Cisco VSM can use a *soft trigger* to perform an action (such as adjusting a camera's PTZ settings). The soft trigger is activated when Cisco VSM receives a URL from an external system, such as ICPAM.

For example, when a door is forced open, a Door Forced Open event is generated and a URL can be sent to Cisco VSM. Cisco VSM then executes actions based on that URL, such as panning the camera and creating a video archive. The process works as follows:

1. Create a event in Cisco VSM, and choose the *Enable Soft Trigger* option. A URL used to trigger the event is automatically generated and displayed.
2. In ICPAM, create a URL action using the Cisco VSM URL that was automatically generated when you created the VSM soft trigger.
3. In ICPAM, create an automation rule (global I/O rule) that triggers the URL action when a *door forced open* event occurs.
4. ICPAM sends the URL to Cisco VSM.
5. When Cisco VSM receives the URL, the camera pans and a video archive is created.

Figure 15-8 illustrates this example.

Figure 15-8 Soft Trigger Event in Cisco VSM

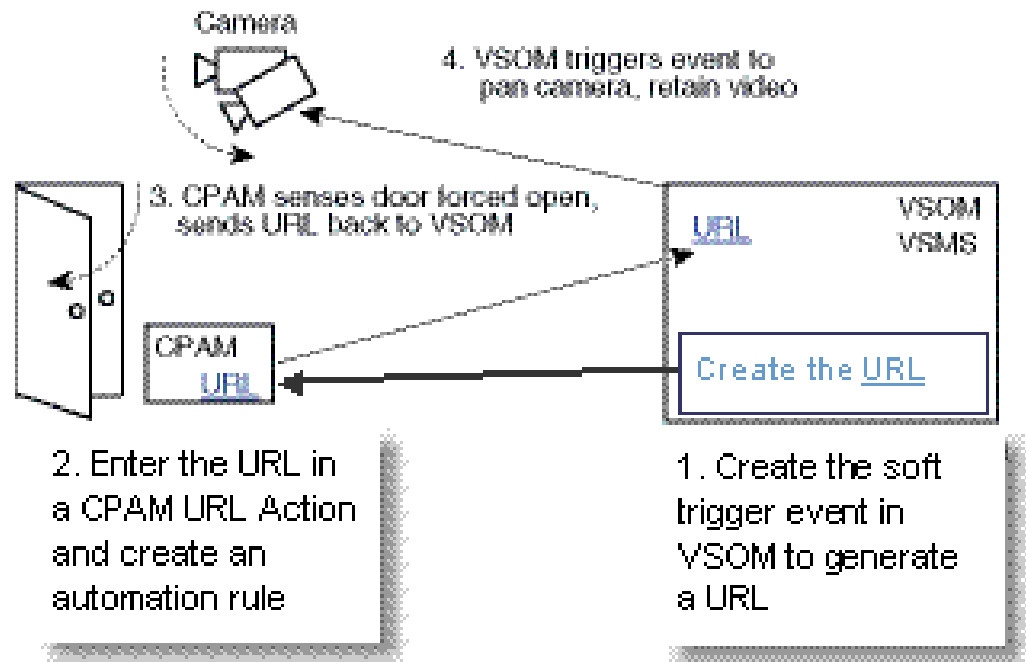

#### Tip

See the [Cisco Video Surveillance Manager User Guide](#) for instructions about how to create Cisco VSM soft triggers.

## VoIP Integration

---

The integration of VoIP phone to ICPAM enables users to grant access to doors through the VoIP phone. This new feature of ICPAM allows the entry of personnel without badges. The VoIP integration does not require any configuration on ICPAM. The ICPAM user receives the access request from the personnel/employees, enquires the credentials, and grants them access through the VoIP phone.

VoIP phone integration to ICPAM is achieved by the following processes:

- Creating a phone service in the **Unified Call Manager (UCM)** and
- Subscribing a service to a VoIP phone.

### Contents

- [Creating a Phone Service in UCM, page 16-2](#)
- [Subscribing a service to a VoIP Phone, page 16-5](#)

## Creating a Phone Service in UCM

By creating a service in UCM, you establish a link between the ICPAM and UCM. The ICPAM IP is given while creating the service. The services can be created for single door or multiple doors in ICPAM. You need to ensure that the URL is validated before creating a service.

For example, if you paste this URL in your Web browser to list all doors:

<http://10.78.177.196/IPPhoneManager.jsp?UserName=cpamadmin&pass=cisco&method=authenticate>  
the following page with the URL should be displayed in your screen.

Figure 16-1 Validating the URL

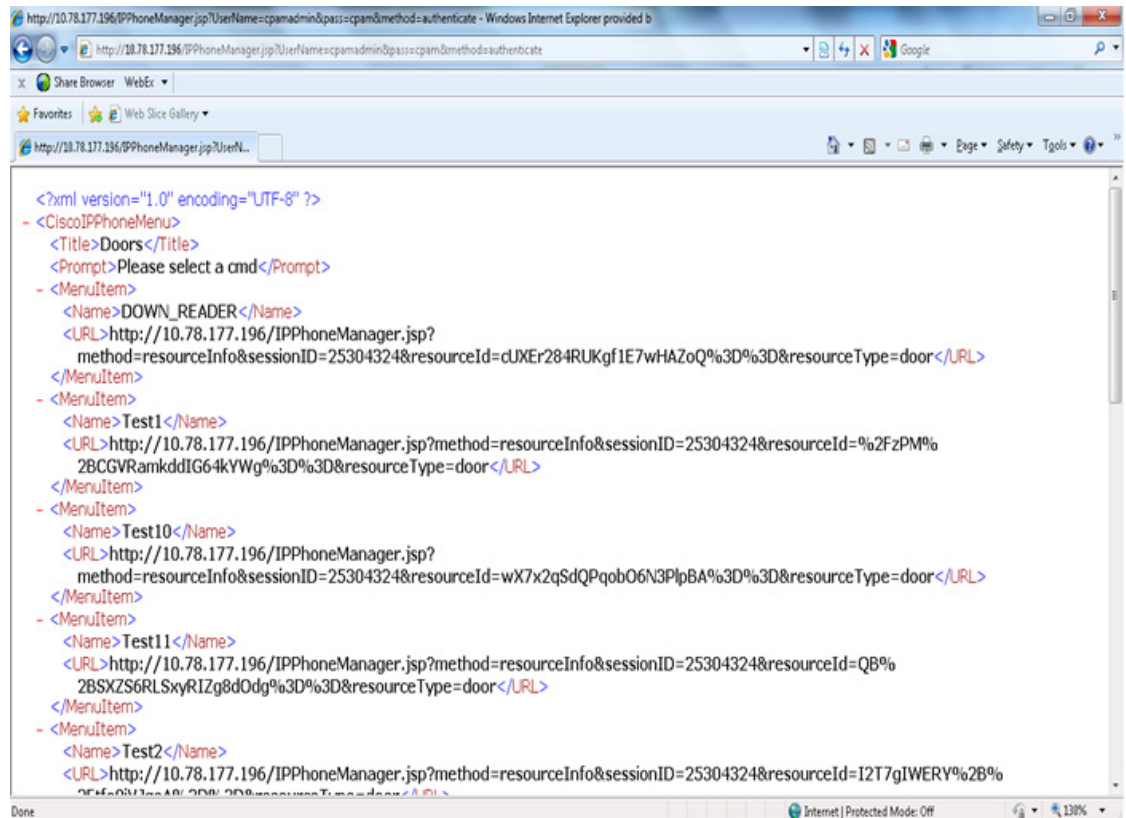

### Procedure

To create a phone service, do the following:

- Step 1 Go to the UCM Administration page.
- Step 2 Choose **Device -> Device Settings -> Phone Services**.

Figure 16-2 UCM Phone Services

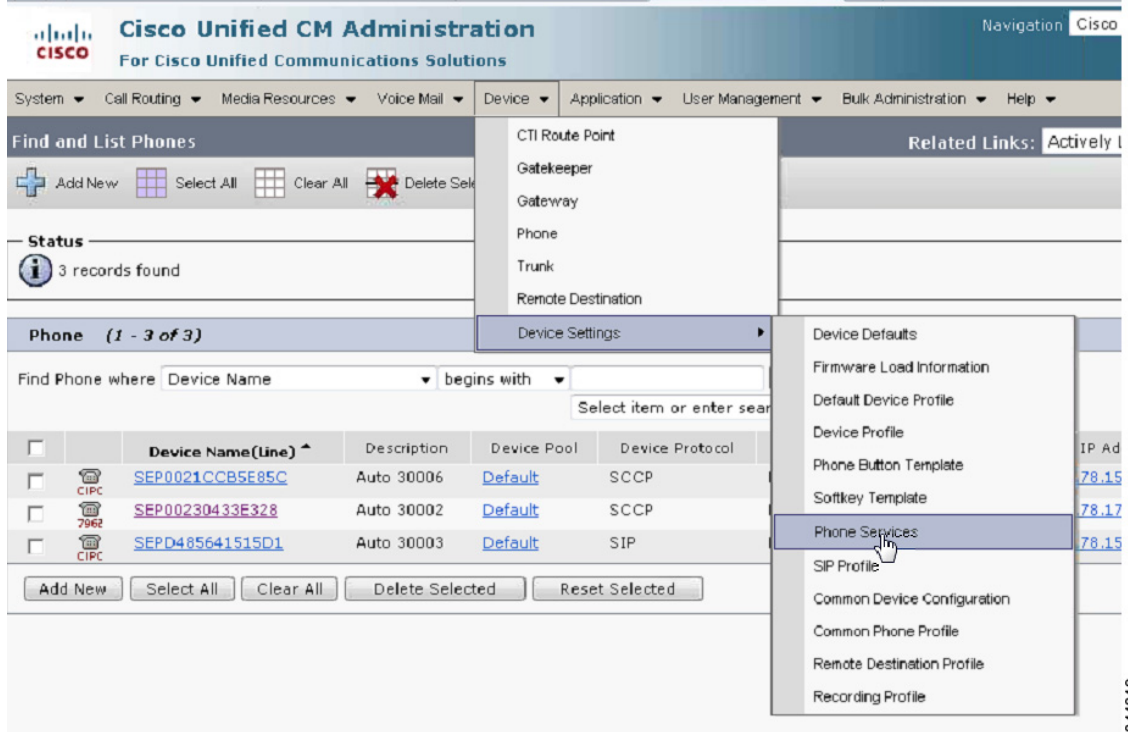

**Step 3** Click **Add New** to create a new service.

- You can also modify existing services.

**Step 4** Enter the details in the **IP Phone Services Configuration** window.



**Note**

Enter the ICPAM IP in the **The Service URL\*** field. You can give an URL to display all doors, or a static URL that will display specific doors. Ensure that you add the unique ID of the door in the URL if it is for static door configuration.



**Tip**

To configure for a single door, use an URL with the following form:  
`http://ip_address_of_icpam/QuickUnlock.jsp?UserName=<cpamadmin>  
 &pass=<password_for_cpamadmin>&method=authenticate  
 &resourceId=<Door_Unique_ID>&resourceType=door`

Figure 16-3 Service URL

**Cisco Unified CM Administration**  
For Cisco Unified Communications Solutions

System ▾ Call Routing ▾ Media Resources ▾ Voice Mail ▾ Device ▾ Application ▾ User Management ▾

**IP Phone Services Configuration**

Save Delete Update Subscriptions Add New

**Status**  
Status: Ready

**Service Information**

Service Name\* P\_15

ASCII Service Name\* P\_15

Service Description

Service URL\* <http://10.78.177.180/QuickUnlock.jsp?resourceId=vh8h>

Service Category\* XML Service

Service Type\* Standard IP Phone Service

Service Vendor

Service Version

Enable

**Step 5** Click **Save**.

The service is created.

## Additional Information

ICPAM supports three different types of URLs, which you can configure for your needs.

### URL 1: Just the URL

`http://<ip_address_of_icpam>/IPPhoneManager.jsp`

Use the above type of URL to create a service without a username and password to display all doors. The user will be requested for the user credentials for each access.

### URL 2: URL with Username and Password:

`http://<ip_address_of_icpam>/IPPhoneManager.jsp?method=authenticate  
&UserName=<cpamadmin>& pass=<password_for_icpamadmin>`

Use the above URL to create a service with a username and password to display all doors. The user will be able to select a door and grant access, without giving the user credentials each time.



This type of useful can be helpful for a receptionist in a busy school/university. If the number of keystrokes necessary to unlock a low-security door using the phone are too many, then you can pre-configure the URL with the receptionist's Username and Password.

**URL 3: Quick unlock: Just one click to unlock/grant access to the door:**

```
http://<ip_address_of_icpam>/QuickUnlock.jsp?method=authenticate&UserName=<cpamadmin>
&pass=<password_for_icpamadmin>&resourceId=<Door_Unique_ID>&resourceType=door
```

## More Information about the URLs

**For quick unlock of a door:**

```
http://<ip_address_of_icpam>/QuickUnlock.jsp?UserName=<cpamadmin>
&pass=<password_for_cpamadmin>&method=authenticate
&resourceId=<Door_Unique_ID>&resourceType=door
```

Configure the above URL as a service and name it "Door name to be unlocked". Select the Service and the door will unlock, you will see the user friendly message on the phone.

**To retrieve Resource ID:**

```
http://<ip_address_of_icpam>/IPPhoneManager.jsp?method=authenticate
&UserName=cpamadmin&pass=cpam
```

Go to the above URL to see the list of doors and select the door to configure as the individual door.

**To authenticate username and password:**

```
http://<ip_address_of_icpam>/IPPhoneManager.jsp?method=authenticate
&UserName=cpamadmin&pass=cpam
```

## Subscribing a service to a VoIP Phone

These steps enable you to subscribe a service to the VoIP phone. After being subscribed, the doors are displayed on the phone UI. The user can now grant access to those doors.



Note

---

To configure a VoIP phone to UCM, contact the UCM Admin.

---

## Procedure

- 
- Step 1** Go to **Device->Phone** in the UCM Admin page.  
The Find and List Phones window appears.
- Step 2** Select and click a specific VoIP phone from the list.  
The phone configuration window appears.

Figure 16-4 Selecting a VoIP Phone

| Phone (1 - 3 of 3)                                                                                                                                   |                   |             |             |                 |                              |               |
|------------------------------------------------------------------------------------------------------------------------------------------------------|-------------------|-------------|-------------|-----------------|------------------------------|---------------|
| Find Phone where Device Name begins with <input type="text"/> Find Clear Filter <input type="button"/> <input type="button"/> <input type="button"/> |                   |             |             |                 |                              |               |
| Select item or enter search text                                                                                                                     |                   |             |             |                 |                              |               |
| <input type="checkbox"/>                                                                                                                             | Device Name(Line) | Description | Device Pool | Device Protocol | Status                       | IP Address    |
| <input type="checkbox"/>                                                                                                                             | SEP0021CCB5E81FC  | Auto 30006  | Default     | SCCP            | Registered with 10.78.179.75 | 10.78.152.122 |
| <input type="checkbox"/>                                                                                                                             | SEP00230433E328   | Auto 30002  | Default     | SCCP            | Registered with 10.78.179.75 | 10.78.177.253 |
| <input type="checkbox"/>                                                                                                                             | SEPD48564151SD1   | Auto 30003  | Default     | SIP             | Registered with 10.78.179.75 | 10.78.153.39  |

Step 3 From the **Related Links** drop-down list, choose **Subscribe/Unsubscribe Services**, and then click **Go**.

Figure 16-5 Related Link to Subscribe/Unsubscribe Services

The screenshot shows the Cisco Unified CM Administration interface. The top navigation bar includes 'Navigation Cisco Unified CM Administration' and 'Go'. Below the navigation bar, there are tabs for 'admin', 'Search Documentation', 'About', and 'Logout'. The main content area displays a 'Phone Type' section with 'Product Type: Cisco 9971' and 'Device Protocol: SIP'. Below this is the 'Device Information' section, which includes fields for 'Registration', 'IP Address', 'Active Load ID', 'Inactive Load ID', 'Download Status', 'Device is Active', 'Device is trusted', 'MAC Address', 'Description', 'Device Pool', and 'Common Device Configuration'. The 'Related Links' dropdown menu is open, showing options such as 'Back To Find/List', 'Dependency Records', 'Add a New Line Appearance', 'Add/Update Speed Dials', 'Add/Update Busy Lamp Field Speed Dials', 'Add/Update Busy Lamp Field Directed Call Park', 'Subscribe/Unsubscribe Services' (highlighted in blue), 'Copy to Remote Destination Profile', and 'Migrate Phone'. The 'Go' button next to the dropdown is highlighted in red.

Step 4 Select a Service from the drop-down list, then click **Next**.

Figure 16-6 Select a service

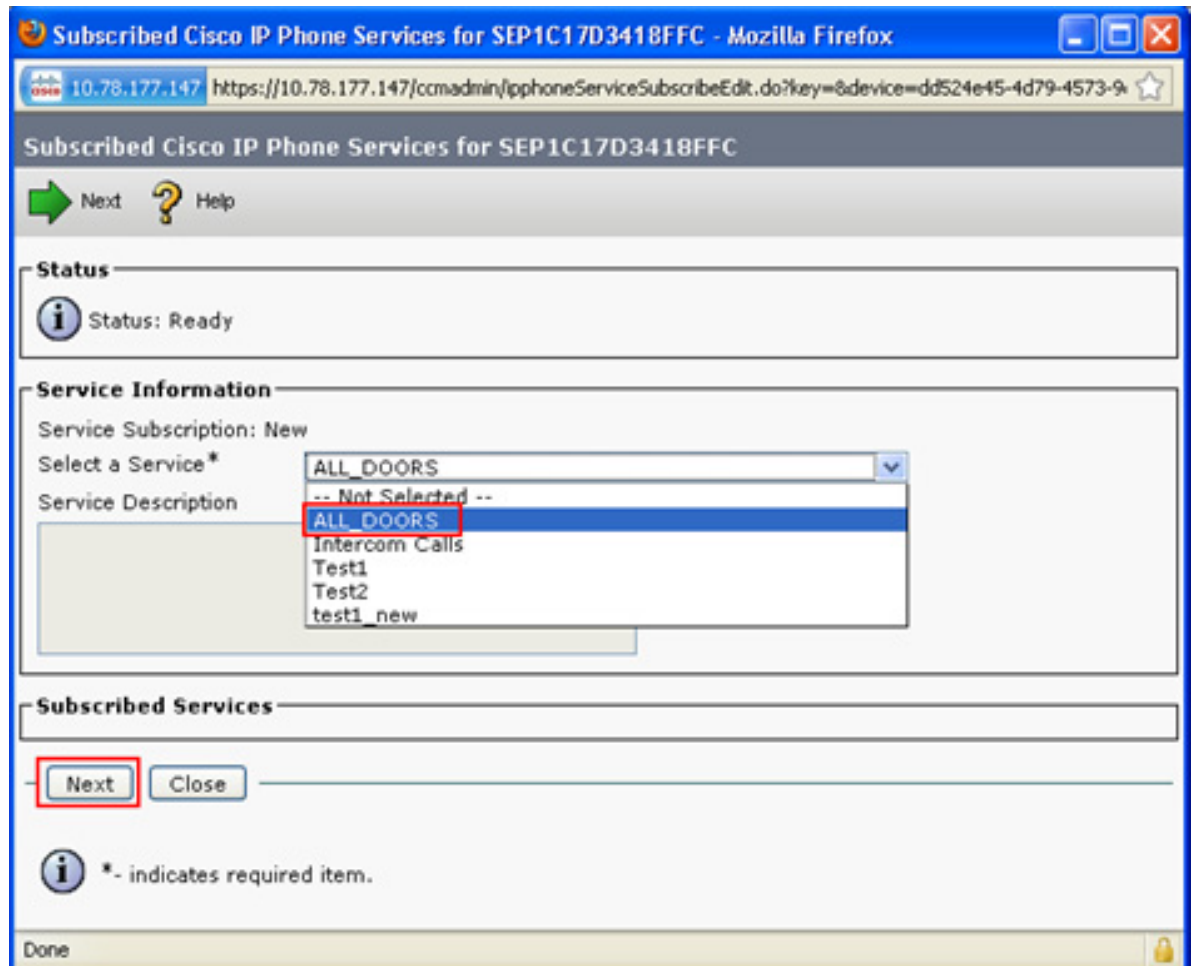

**Step 5** Click **Subscribe**.

The service is now subscribed to the phone and is listed under Subscribed Services.

*Figure 16-7 Service Subscribed*

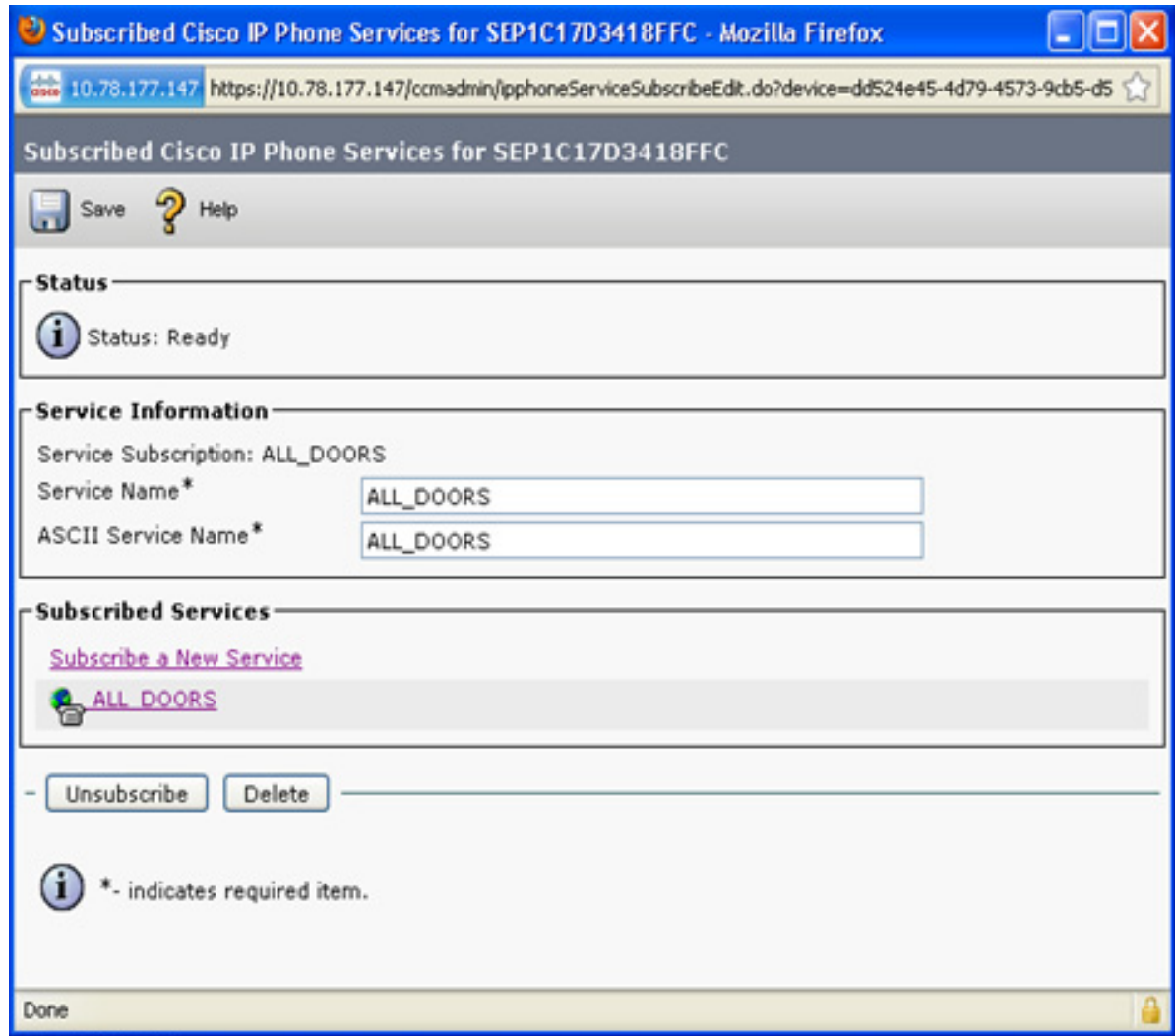

**Note** To subscribe to more services, click the **Subscribe a New Service** link in the subscribed services.

**Step 6** Click **Save** and close the window.

The service is subscribed now.

To display the service on the VoIP phone, follow the steps below:

- Step 1** Click **Add a new SURL** under Associate Information in the Phone Configuration window.

*Figure 16-8 Add a new SURL*

The screenshot displays the 'Phone Configuration' interface. At the top, there is a toolbar with icons for Save, Delete, Copy, Reset, Apply Config, and Add New. Below the toolbar, the 'Status' section shows 'Status: Ready'. The main area is divided into two columns. The left column, 'Association Information', contains a list of lines (1-10) with a 'Modify Button Items' button above it. The third line is highlighted, and a red box around the 'Add a new SURL' button is visible. The right column, 'Phone Type', shows 'Product Type: Cisco 9971' and 'Device Protocol: SIP'. Below this, the 'Device Information' section lists various fields: Registration (Registered with Cisco Unified Communications Manager 10.78.177.147), IP Address (10.78.177.138), Active Load ID (sip9971.9-3-1-16), Inactive Load ID (sip9971.9-0-0-77), Download Status (Unknown), Device is Active (checked), Device is trusted (checked), MAC Address\* (1C17D3418FFC), Description (Auto 50004), Device Pool\* (Default), and Common Device Configuration (< None >). 'View Details' links are provided for the Device Pool and Common Device Configuration fields.

**Step 2** Select the service to configure the service URL button.

*Figure 16-9 Configure Service URL button*

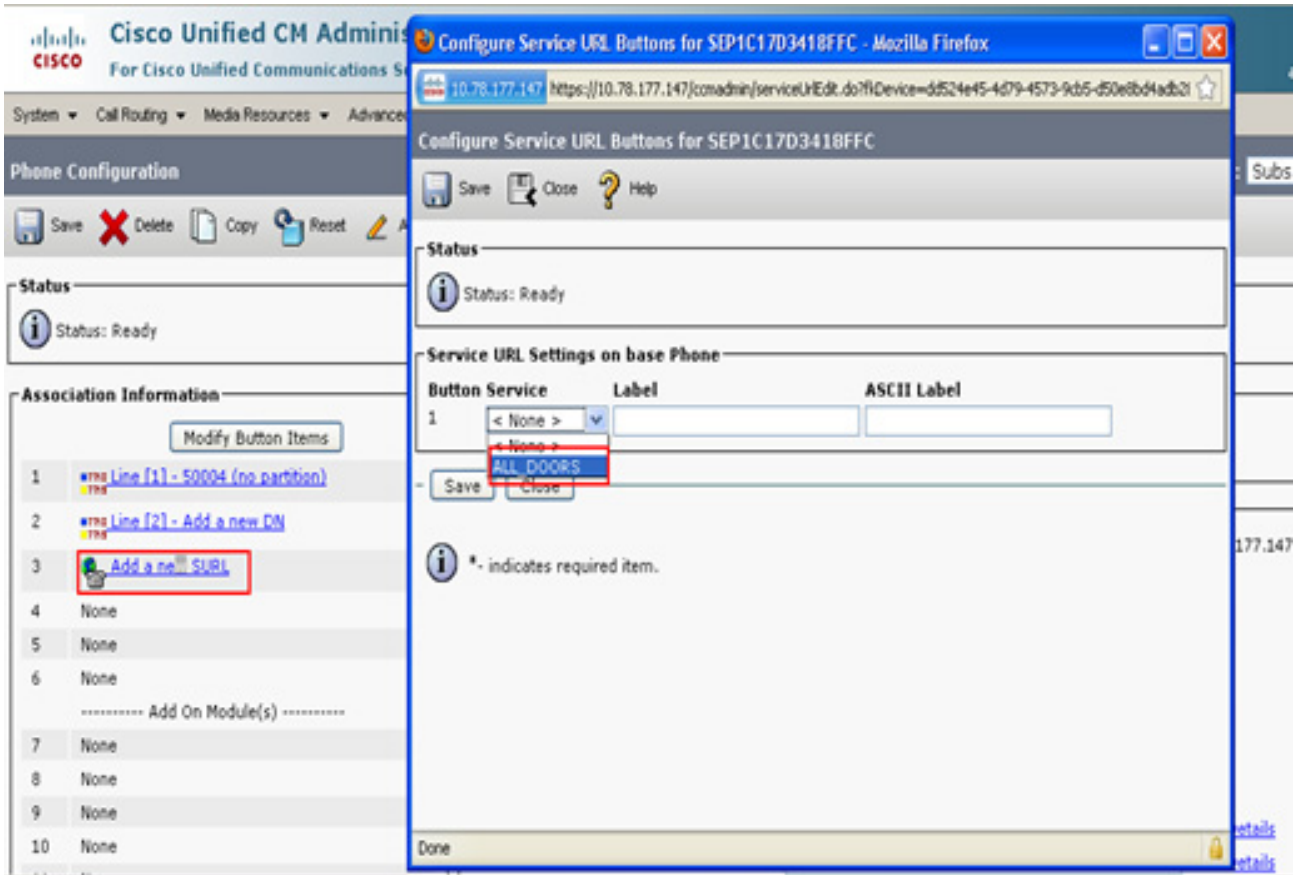

**Step 3** Click **Save**.

The service is listed in the VoIP phone.

**Step 4** On the VoIP phone, click the button next to the service.

The user credentials are requested.

**Step 5** Enter the **Username** and **Password**, and then click **Submit** to display the door(s).

*Figure 16-10 User Name and Password*



**Step 6** Press the button next to the selected door.

- The services are displayed based on user profile. Only doors assigned to the user login will be displayed.
- For an admin user (such as cpamadmin), all doors will be displayed.

If the credentials are true, the following message is displayed.

- Successfully granted access on Door\_8 (name of the door).

If the credentials are false, the following message is displayed.

- Authentication failed.



**Note**

- If you have configured a list of doors to a service, then you have to select the door from the list displayed on the phone.
- The VoIP phone displays the list of doors in alphabetic order. The doors are displayed in any of the states such as “UNKNOWN, UP, DOWN, MISMATCH”.

The events are displayed in ICPAM under **Events and Alarms->Monitoring->Events**.

**Figure 16-11** Events

| Events & Alarms Users Doors Admin Reports Options Help               |                   |                                          |               |                          |
|----------------------------------------------------------------------|-------------------|------------------------------------------|---------------|--------------------------|
| Scroll Lock Clear List View... Report... Columns... Filter... Search |                   |                                          |               |                          |
| n                                                                    | Device            | Address                                  | Personnel ... | Data                     |
| t Access                                                             | H_8               | /Chennai/gw_FOC144888G1/Door/door03      |               |                          |
| mand: Grant Access                                                   | CPAM_SERVER       | 127.0.0.1                                |               |                          |
| n: Logged In                                                         | CPAM_SERVER       | 127.0.0.1                                |               |                          |
| ogged in                                                             | CPAM_SERVER       | 127.0.0.1                                |               | pzfkdDrLR3C+3JshKsuTzw== |
| ogged out                                                            | CPAM_SERVER       | 127.0.0.1                                |               | 8TrUkZmISeOKN5Ib10WvQw== |
| n: Logged Out                                                        | CPAM_SERVER       | 127.0.0.1                                |               |                          |
| n: Logged In                                                         | jansubra-ws       | 10.78.152.122                            |               |                          |
| ogged in                                                             | jansubra-ws       | 10.78.152.122                            |               | gw7Y7TEdQQGasq1ssYoVcg== |
| n rule: Invoked                                                      | Automation Driver | localhost                                |               | rese                     |
| code Failed                                                          | reader            | /Chennai/gw_FOC144888H5/m01/rdr02/reader |               |                          |
| code Failed                                                          | reader            | /Chennai/gw_FOC144888H5/m01/rdr02/reader |               |                          |
| code Failed                                                          | reader            | /Chennai/gw_FOC144888H5/m01/rdr02/reader |               |                          |
| Used                                                                 | E_5               | /Chennai/gw_FOC144888G1/Door/door00      |               |                          |
| t Access                                                             | E_5               | /Chennai/gw_FOC144888G1/Door/door00      |               |                          |
| mand: Grant Access                                                   | CPAM_SERVER       | 127.0.0.1                                |               |                          |
| n: Logged In                                                         | CPAM_SERVER       | 127.0.0.1                                |               |                          |
| ogged in                                                             | CPAM_SERVER       | 127.0.0.1                                |               | 8TrUkZmISeOKN5Ib10WvQw== |
| ogged out                                                            | CPAM_SERVER       | 127.0.0.1                                |               | hEjKXdCYTouPvVa11yINsQ== |
| n: Logged Out                                                        | CPAM_SERVER       | 127.0.0.1                                |               |                          |
| from an IP Phone                                                     | 10.78.153.39      | 10.78.153.39                             |               | External IP Phone        |
| Used                                                                 | E_5               | /Chennai/gw_FOC144888G1/Door/door00      |               |                          |
| t Access                                                             | E_5               | /Chennai/gw_FOC144888G1/Door/door00      |               |                          |
| mand: Grant Access                                                   | CPAM_SERVER       | 127.0.0.1                                |               |                          |

## Limitations

- A VoIP phone can support the display of up to 100 doors. If a server has more than 100 doors, then you need to configure the remaining doors as a static URL.
- A disabled door will not be available in the list of doors displayed on the VoIP phone.



## System Configuration Settings

This chapter describes the ICPAM system-wide settings available in the System Configuration module. The System Configuration module includes additional settings through which a user profile can be associated to a location hierarchy. This feature allow the users to control or execute actions on locations and sub locations mapped to their user profile. See [Logins page of the System Configuration window, page 17-11](#).



Note

We recommend restricting access to the **System Configuration** module to administrators only.

To modify the system configuration settings, perform these general steps:

- Step 1** Select **System Configuration** from the **Admin** menu.
- Step 2** Select a configuration category from the tabs on the left ([Figure 17-1](#)).
- Step 3** Enter the appropriate settings and configurations as described in the sub-sections listed below.
- Step 4** Click **Save** to save the changes made in a system configuration window.
- Step 5** Log out (select **Logout** from the **Options** menu) and log back in to the ICPAM application to activate the changes.



Note

Changes to the system configuration settings do not take effect until you stop and restart the ICPAM application. For some settings on the **Advanced** page of the System Configuration window, you must restart the ICPAM appliance. See [Table 17-20 on page 17-38](#) for more information.

### Contents

- [LDAP page of the System Configuration window, page 17-3](#)
- [Event/Alarms page of the System Configuration window, page 17-5](#)
- [Personnel page of the System Configuration window, page 17-7](#)
- [Badges page of the System Configuration window, page 17-9](#)
- [Logins page of the System Configuration window, page 17-11](#)
- [Password Policy page of the System Configuration window, page 17-13](#)
- [Personnel - Custom page of the System Configuration window, page 17-14](#)

- [Devices - Custom page of the System Configuration window, page 17-17](#)
- [Badges - Custom page of the System Configuration window, page 17-19](#)
- [ID Number Generator page of the System Configuration window, page 17-21](#)
- [PIN Generator page of the System Configuration window, page 17-22](#)
- [Card Number Generator page of the System Configuration window, page 17-23](#)
- [Support Contact page of the System Configuration window, page 17-25](#)
- [Badge Designer page of the System Configuration window, page 17-26](#)
- [Badge Printing page of the System Configuration window, page 17-28](#)
- [Image Processing page of the System Configuration window, page 17-30](#)
- [Miscellaneous page of the System Configuration window, page 17-32](#)
- [Temporary Badge Wizard page of the System Configuration window, page 17-34](#)
- [General UI page of the System Configuration window, page 17-36](#)
- [Advanced page of the System Configuration window, page 17-37](#)
- [Identiv page of the System Configuration window, page 17-40](#)
- [HSPD-12 page of the System Configuration window, page 17-41](#)

# LDAP page of the System Configuration window

The LDAP page of the System Configuration window (shown in [Figure 17-1](#)) includes login validation settings required to use the Lightweight Directory Access Protocol. See [Table 17-1](#) for descriptions of the fields and options on this page.



**Tip**

For more information, see [Configuring LDAP User Authentication, page 4-14](#).

*Figure 17-1 LDAP page of the System Configuration window*

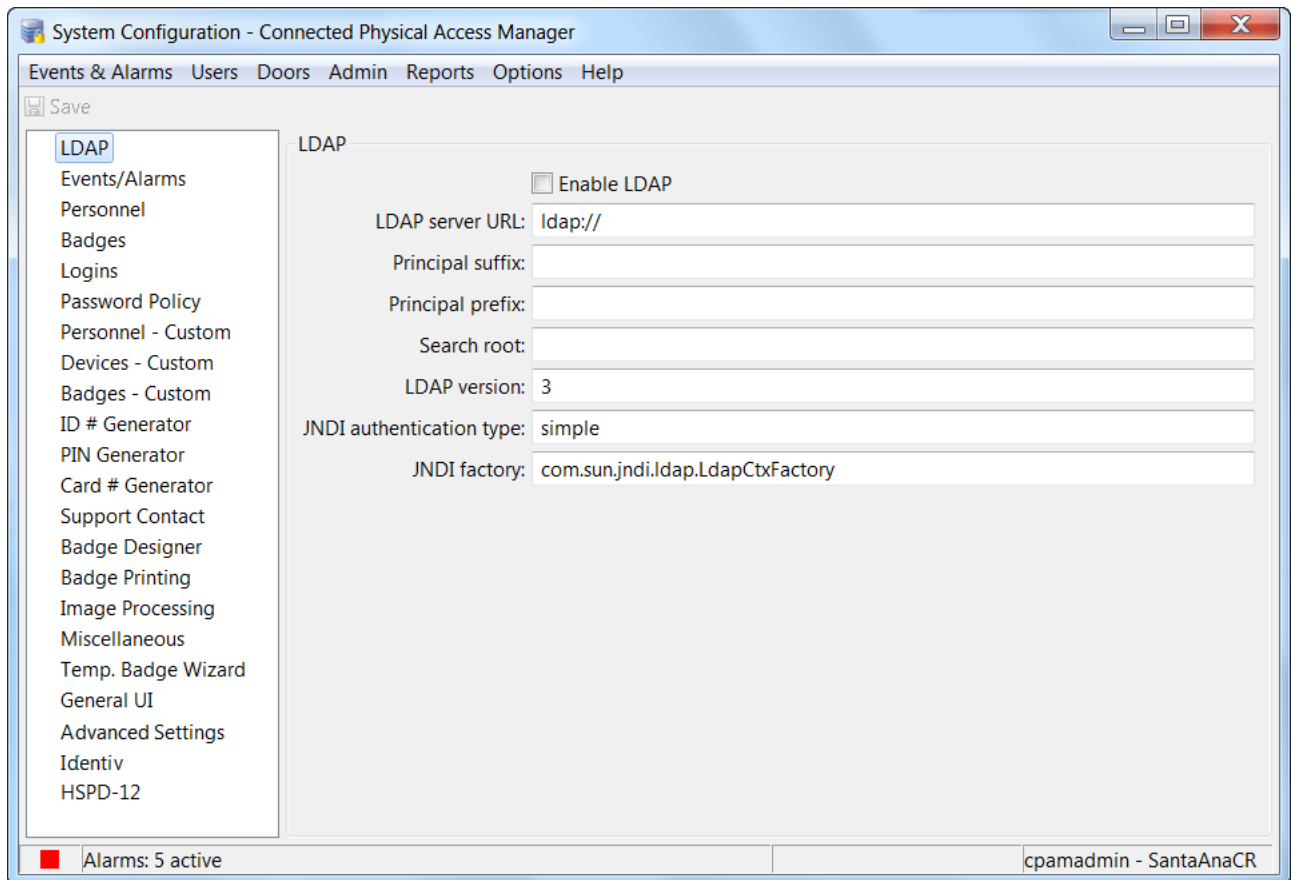

LDAP uses a principal name to authenticate. The principal name is formed from the username: prefix + username + suffix. The exact format of the principal name varies based on the type of LDAP server, and the domain.

- For Active Directory, the prefix should be the (uppercase) domain followed by \\ (example: MY-DOMAIN\\) and the suffix should be blank.
- For OpenLDAP, the prefix should be: uid=  
The suffix should be changed to reflect the actual domain.  
So for my-domain.com, this would be:  
.dc=my-domain,dc=com

Table 17-1 describes the fields and options on the **LDAP** page.

**Table 17-1** Fields and Options on the System Configuration window's LDAP page

| Field or Option                 | Description                                                                                                                                                                                                                                                                                                                                                                                                                                                                                                                                                                                                         |
|---------------------------------|---------------------------------------------------------------------------------------------------------------------------------------------------------------------------------------------------------------------------------------------------------------------------------------------------------------------------------------------------------------------------------------------------------------------------------------------------------------------------------------------------------------------------------------------------------------------------------------------------------------------|
| <b>Enable LDAP</b>              | Click the check box to enable or disable LDAP support.                                                                                                                                                                                                                                                                                                                                                                                                                                                                                                                                                              |
| <b>LDAP server URL</b>          | URL of the LDAP server, which must begin with <code>ldap://</code><br>Example: <code>ldap://192.168.1.1</code>                                                                                                                                                                                                                                                                                                                                                                                                                                                                                                      |
| <b>Principal suffix</b>         | Appended to the username for authentication. See above.                                                                                                                                                                                                                                                                                                                                                                                                                                                                                                                                                             |
| <b>Principal prefix</b>         | Prepended to the username for authentication. See above.                                                                                                                                                                                                                                                                                                                                                                                                                                                                                                                                                            |
| <b>Search root</b>              | LDAP search root. The search root is the node in the LDAP tree, the subtree under which the user account should be found. <ul style="list-style-type: none"> <li>For Active Directory, the 2 dc components should be changed to match the full domain name managed by the directory. The following example is for <code>my-domain.com</code>: <code>cn=Users,dc=my-domain,dc=com</code>.</li> <li>For OpenLDAP, the 2 dc components should be changed to match the full domain name managed by the directory. The following example is for <code>my-domain.com</code>: <code>dc=my-domain,dc=com</code>.</li> </ul> |
| <b>LDAP version</b>             | An advanced setting that generally should be left unchanged.                                                                                                                                                                                                                                                                                                                                                                                                                                                                                                                                                        |
| <b>JNDI authentication type</b> | An advanced setting that generally should be left unchanged as <code>simple</code> .                                                                                                                                                                                                                                                                                                                                                                                                                                                                                                                                |
| <b>JNDI factory</b>             | An advanced setting that generally should be left unchanged as <code>com.sun.jndi.ldap.LdapCtxFactory</code>                                                                                                                                                                                                                                                                                                                                                                                                                                                                                                        |



**Note**

Changes to system configuration settings do not take effect until you log out (select **Logout** from the **Options** menu) and log back in to the ICPAM application.

## Event/Alarms page of the System Configuration window

The **Events/Alarms** page of the System Configuration window (shown in [Figure 17-2](#)) includes settings that enable you to specify how alarms are managed by the system, and how much video is recorded for events. See [Table 17-2](#) for descriptions of the fields and options on this page.

*Figure 17-2 Events/Alarms page of the System Configuration window*

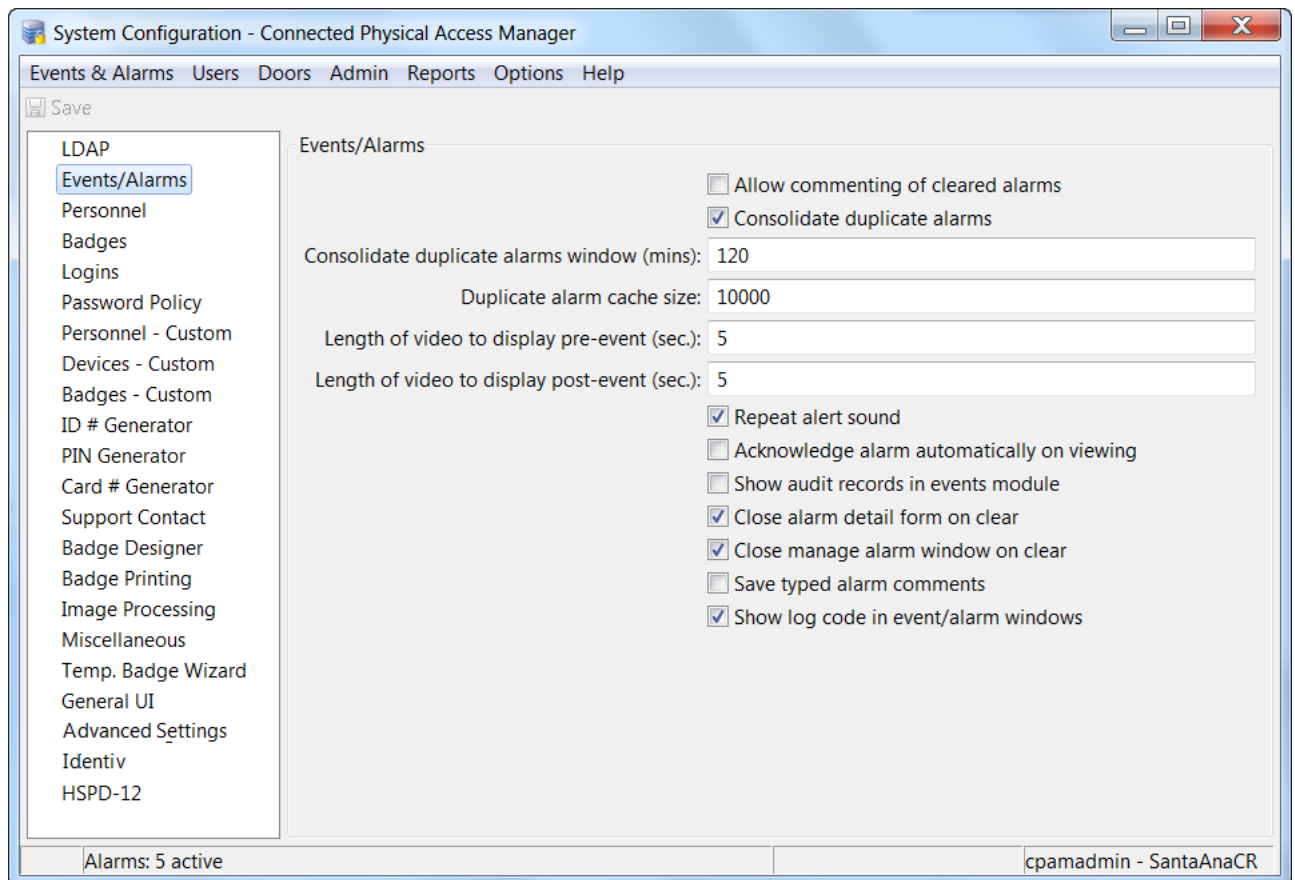

[Table 17-2](#) describes the fields and options on the **Events/Alarms** page.

*Table 17-2 Fields and Options on the System Configuration window's Events/Alarms page*

| Field or Option                                   | Description                                                                                                                                                                                                                                                                                                  |
|---------------------------------------------------|--------------------------------------------------------------------------------------------------------------------------------------------------------------------------------------------------------------------------------------------------------------------------------------------------------------|
| <b>Allow commenting of cleared alarms</b>         | Allow operators to comment on alarms that have already been cleared.                                                                                                                                                                                                                                         |
| <b>Consolidate duplicate alarms window (mins)</b> | If duplicate alarms are being consolidated, this is the maximum time difference between the original and the duplicate. If an alarm that would otherwise be considered a duplicate occurs after this time, it becomes a new original alarm and subsequent duplicate alarms will bump up its duplicate count. |

Table 17-2 Fields and Options on the System Configuration window's Events/Alarms page (continued)

| Field or Option                              | Description                                                                                                                                                                                                                                                                                                                                                                                                                                                      |
|----------------------------------------------|------------------------------------------------------------------------------------------------------------------------------------------------------------------------------------------------------------------------------------------------------------------------------------------------------------------------------------------------------------------------------------------------------------------------------------------------------------------|
| <b>Consolidate duplicate alarms</b>          | Consolidate duplicate alarms identical other than time, into a single alarm, with an increasing alarm count. This is useful for preventing a flood of individual alarms; for example, if an armed alarm point is on an external gate which is flapping in the wind, repeatedly triggering the alarm. It is not recommended that this be unchecked without careful consideration of the possible performance impact of the increased number of individual alarms. |
| <b>Duplicate alarm cache size</b>            | The size of the cache for duplicate alarms.                                                                                                                                                                                                                                                                                                                                                                                                                      |
| <b>Length of video to display pre-event</b>  | The number of seconds of video that are included before the event occurred.                                                                                                                                                                                                                                                                                                                                                                                      |
| <b>Length of video to display post-event</b> | The number of seconds of video that are included after an event occurs.                                                                                                                                                                                                                                                                                                                                                                                          |
| <b>Repeat alert sounds</b>                   | Defines if alarms sounds are played only once, or repeated.                                                                                                                                                                                                                                                                                                                                                                                                      |
| <b>Show audit records in events</b>          | Lists the audit records of events.                                                                                                                                                                                                                                                                                                                                                                                                                               |

**Note**

Changes to system configuration settings do not take effect until you log out (select **Logout** from the **Options** menu) and log back in to the ICPAM application.

## Personnel page of the System Configuration window

The **Personnel** page of the System Configuration window (shown in [Figure 17-3](#)) provides settings for the personnel-related features in ICPAM. See [Table 17-3](#) for descriptions of the fields and options on this page.

*Figure 17-3 Personnel page of the System Configuration window*

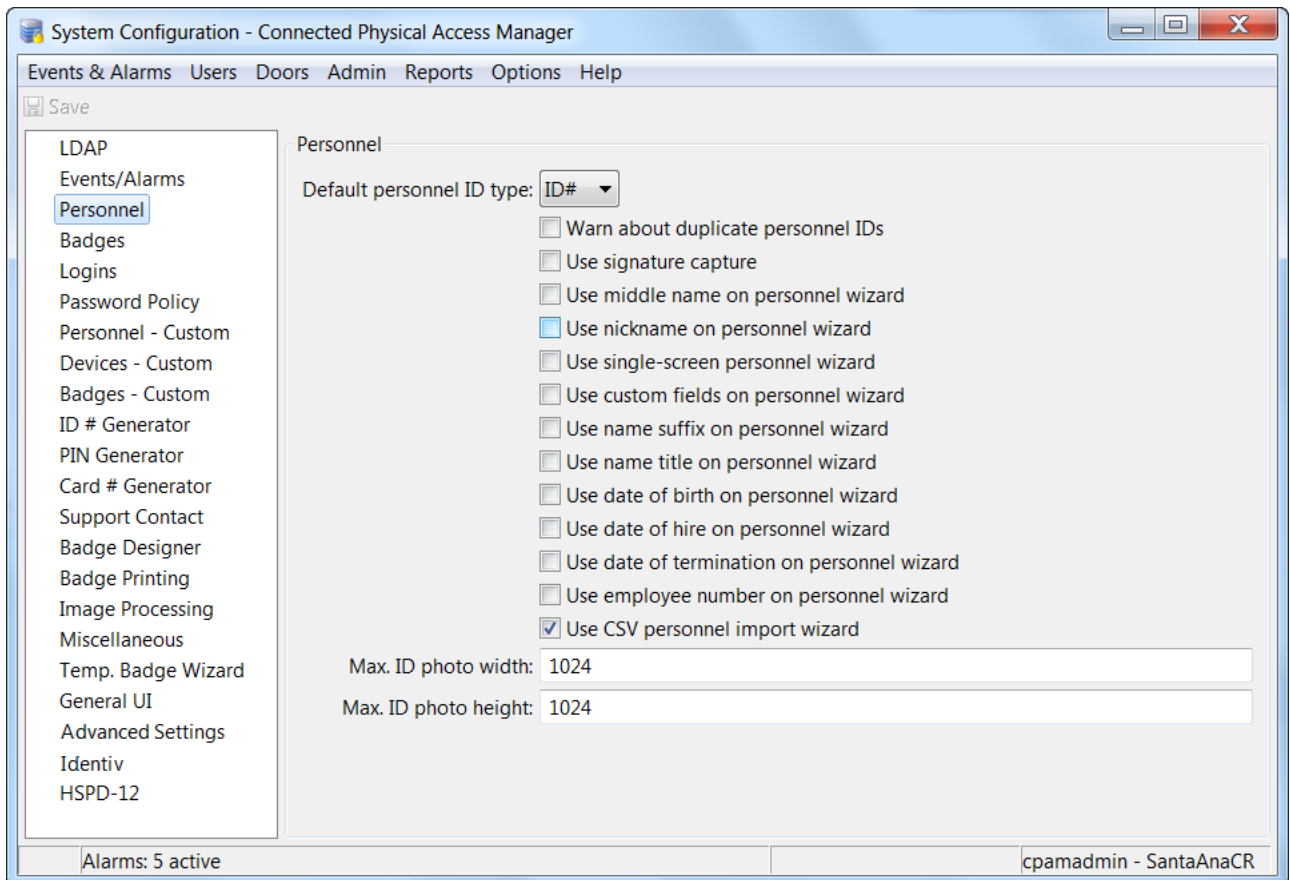

[Table 17-3](#) describes the fields and options on the **Personnel** page.

*Table 17-3 Fields and Options on the System Configuration window's Personnel page*

| Field or Option                           | Description                                                                                                                                                                                                                                                  |
|-------------------------------------------|--------------------------------------------------------------------------------------------------------------------------------------------------------------------------------------------------------------------------------------------------------------|
| <b>Default personnel ID specifier</b>     | The type of personnel ID specifier the field will default to. The various ID specifiers will be available in the drop-down.                                                                                                                                  |
| <b>Warn about duplicate personnel IDs</b> | Warn if personnel are added with duplicate personnel IDs.                                                                                                                                                                                                    |
| <b>Use signature capture</b>              | Enable the ability to capture personnel signatures with a signature capture device. Signature capture devices must be configured in the application preferences before they may be used. See <a href="#">Enabling Signature Capture Devices, page 9-61</a> . |

Table 17-3 Fields and Options on the System Configuration window's Personnel page (continued)

| Field or Option                                    | Description                                                                                                                                                                                                                                     |
|----------------------------------------------------|-------------------------------------------------------------------------------------------------------------------------------------------------------------------------------------------------------------------------------------------------|
| <b>Use single-screen personnel wizard</b>          | Enables a single-screen personnel wizard used for personnel data entry. All personnel information is available on one screen.                                                                                                                   |
| <b>Use custom fields on personnel wizard</b>       | Enable custom fields in the single-screen personnel wizard. This makes the screen larger, but is useful if important data is being stored in the custom fields. Refer to custom fields in the <b>Custom Personnel Fields</b> window.            |
| <b>Use name suffix on personnel wizard</b>         | Choose a value from the drop-down menu (such as I, II, III, Jr., and Sr.) or enter the text manually to add suffix at the end the person's name.                                                                                                |
| <b>Use name title on personnel wizard</b>          | Choose a value from the drop-down menu (such as Dr., Mr., or Ms.) or enter the text manually to add a person's formal title.                                                                                                                    |
| <b>Use date of birth on personnel wizard</b>       | The person's date of birth.                                                                                                                                                                                                                     |
| <b>Use date of hire on personnel wizard</b>        | The date the employee was hired.                                                                                                                                                                                                                |
| <b>Use date of termination on personnel wizard</b> | The date the employee was terminated.                                                                                                                                                                                                           |
| <b>Use employee number on personnel wizard</b>     | The employee number, if applicable. Generally, but not required to be, unique.                                                                                                                                                                  |
| <b>Use CSV personnel import wizard</b>             | Enables the CSV import wizard in the personnel module. The CSV import wizard allows operators to add personnel to ICPAM using a CSV file. See <a href="#">Importing Personnel Records Using a Comma Separated Value (CSV) File</a> , page 9-14. |

**Note**

Changes to system configuration settings do not take effect until you log out (select **Logout** from the **Options** menu) and log back in to the ICPAM application.



## Badges page of the System Configuration window

The **Badges** page of the System Configuration window (shown in [Figure 17-4](#)) provides settings for badges and PINs in ICPAM. See [Table 17-4](#) for descriptions of the fields and options on this page.

*Figure 17-4 Badges page of the System Configuration window*

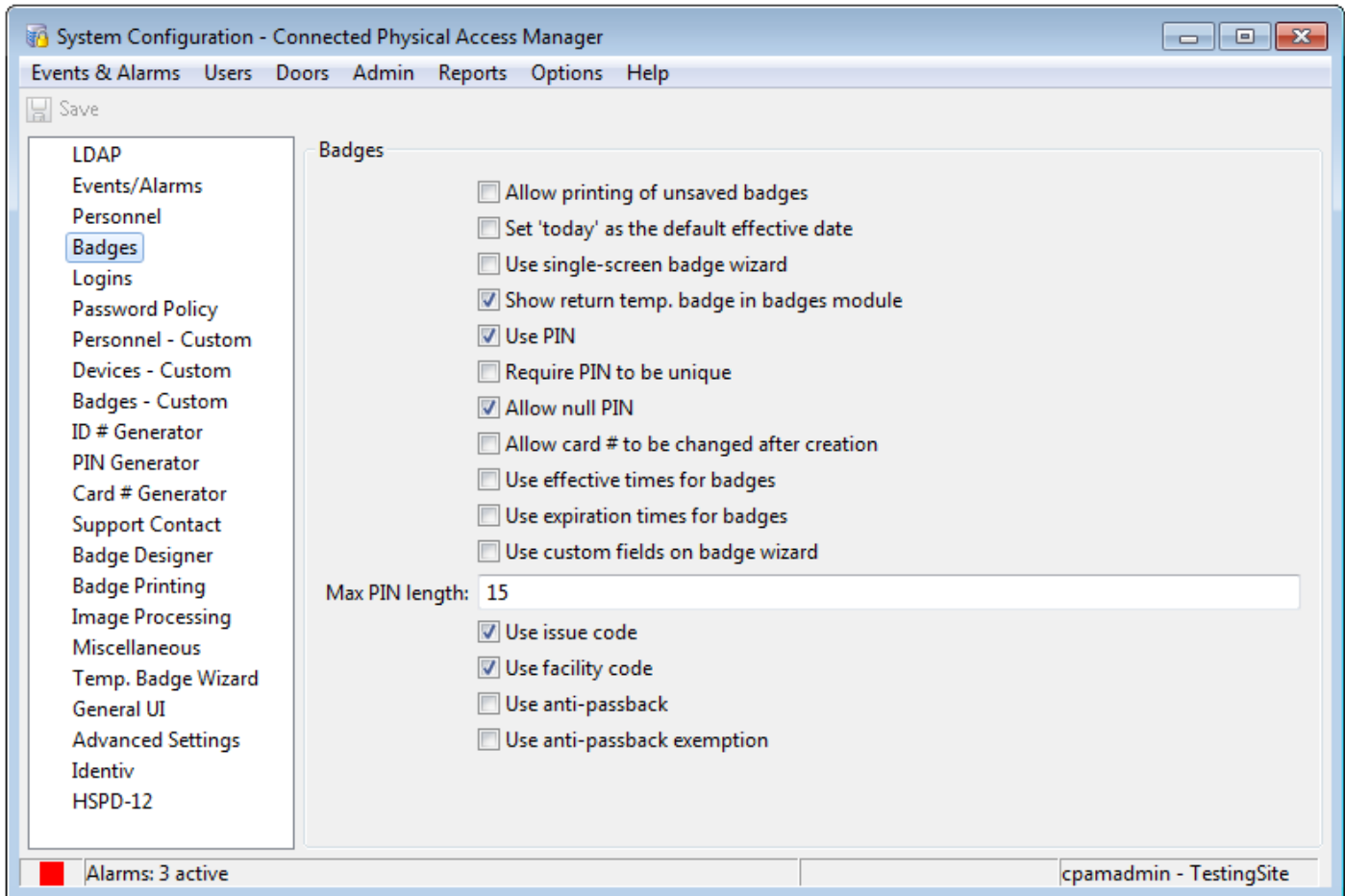

[Table 17-4](#) describes the fields and options on the **Badges** page.

*Table 17-4 Fields and Options on the System Configuration window's Badges page*

| Field or Option                                  | Description                                                                                                                                                                                                            |
|--------------------------------------------------|------------------------------------------------------------------------------------------------------------------------------------------------------------------------------------------------------------------------|
| <b>Allow printing of unsaved badges</b>          | Allows printing new badges before the badge is saved. For highest security, leave this unchecked. When allowed (which may be more convenient), it is possible to print a badge without having any record of the badge. |
| <b>Set 'today' as the default effective date</b> | Uses the current date as a new badge effective date.                                                                                                                                                                   |
| <b>Use single-screen badge wizard</b>            | Enables a single-screen badge wizard for data entry. Most badge properties are on one screen.                                                                                                                          |

Table 17-4 Fields and Options on the System Configuration window's Badges page (continued)

| Field or Option                                    | Description                                                                                                                                                                                           |
|----------------------------------------------------|-------------------------------------------------------------------------------------------------------------------------------------------------------------------------------------------------------|
| <b>Show return temporary badge in badge module</b> | Displays return badge field in the badge module window if the field is checked.                                                                                                                       |
| <b>Use PIN</b>                                     | A PIN associated with the badge. Depending on the configuration of an access point, the pin is entered into the keypad on the access point's reader.                                                  |
| <b>Require PIN to be unique</b>                    | Requires cardholder PINs to be unique. Useful in systems that use PIN-only access-control.                                                                                                            |
| <b>Allow null PIN</b>                              | Allows badges to have null PINs. Useful in systems that do not use PIN for access-control.                                                                                                            |
| <b>Allow card # to be changed after creation</b>   | Also known as a badge. A type of credential encoded with a card number, generally on a magnetic stripe or a proximity card, and used to enter access points.                                          |
| <b>Require numeric hot stamp</b>                   | Requires hot stamp field to be numeric.                                                                                                                                                               |
| <b>Disallow leading zeros in hot stamp</b>         | Prohibits users from adding hot stamps with leading zeros.                                                                                                                                            |
| <b>Use effective times for badges</b>              | Select this check box to enable the effective time constraint for badges, in addition to effective date, which is always enabled.                                                                     |
| <b>Use expiration times for badges</b>             | Select this check box to enable the expiration time constraint for badges, in addition to effective date, which is always enabled.                                                                    |
| <b>Use custom fields on badge wizard</b>           | Enables custom fields in the badge wizard. This makes the screen larger, but is useful if important data is being stored in the custom fields.                                                        |
| <b>Max PIN Length</b>                              | The maximum number of characters in a PIN.                                                                                                                                                            |
| <b>Use issue code</b>                              | Displays the issue code field in the single screen badge wizard if the field is checked.                                                                                                              |
| <b>Use facility code</b>                           | A segment of bits encoded on a card that represents a number for a facility. Often all cards issued for a single facility have the same facility code.                                                |
| <b>Use anti-passback</b>                           | Enables the badge holder to be anti-passback exempt during the next reader use. After enabling this option "Grant one free APB button" is displayed in the badges.                                    |
| <b>Use anti-passback exemption</b>                 | Enables the badge to be exempt from anti-passback enforcement if the access point is configured for anti-passback. After enabling this option "exempt from anti-passback" is displayed in the badges. |

**Note**

Changes to system configuration settings do not take effect until you log out (select **Logout** from the **Options** menu) and log back in to the ICPAM application.

## Logins page of the System Configuration window

The **Logins** page of the System Configuration window (shown in [Figure 17-5](#)) provides settings for logins to ICPAM, including the profile enhancement feature which enables the administrator to link a user profile to a hierarchial location. See [Table 17-5](#) for descriptions of the fields and options on this page.

*Figure 17-5 Logins page of the System Configuration window*

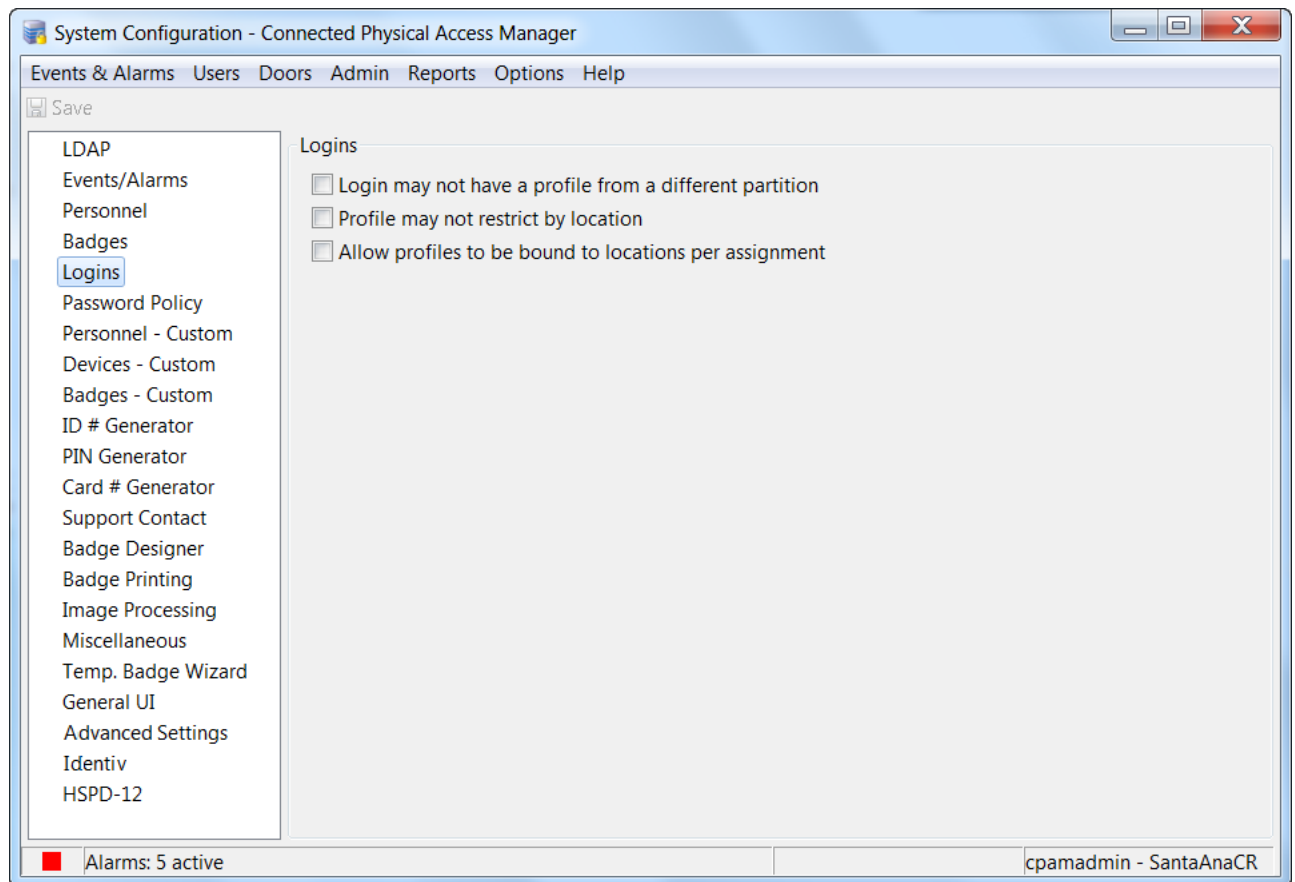

[Table 17-5](#) describes the fields and options on the **Logins** page.

*Table 17-5 Fields and Options on the System Configuration window's Logins page*

| Field or Option                                                          | Description                                                                                      |
|--------------------------------------------------------------------------|--------------------------------------------------------------------------------------------------|
| <b>Login may not have a profile from a different partition</b>           | Not supported in this version                                                                    |
| <b>Profile may not restrict by hierarchial location</b>                  | Select this check box if you do not want user profiles to be restricted by hierarchial locations |
| <b>Allow profile to be bound to hierarchial locations per assignment</b> | Select this check box if you want user profiles to be restricted by hierarchial locations        |

On setting these changes, a user is able to associate a location to a login, thereby granting privileges to the login user for devices in that location. Also a user can be associated to several profiles and the one with higher privileges is applied to the login user.

**Tip**

---

To associate profiles to a hierarchical location, you must select both **Profile may not restrict by hierarchical location** and **Allow profile to be bound to hierarchical locations per assignment**.

---

**Note**

---

If the user does not select the fields that associate profiles to locations, the user profile actions are not restricted to the locations or sub-locations that they belong to. (The configuration settings would then reflect the CPAM 1.5.1 release.)

---

# Password Policy page of the System Configuration window

The **Password Policy** page of the System Configuration window (shown in [Figure 17-6](#)) provides settings that determine password expiration and strength requirements, and the set of special characters. See [Table 17-6](#) for descriptions of the fields and options on this page.

**Figure 17-6** Password Policy page of the System Configuration window

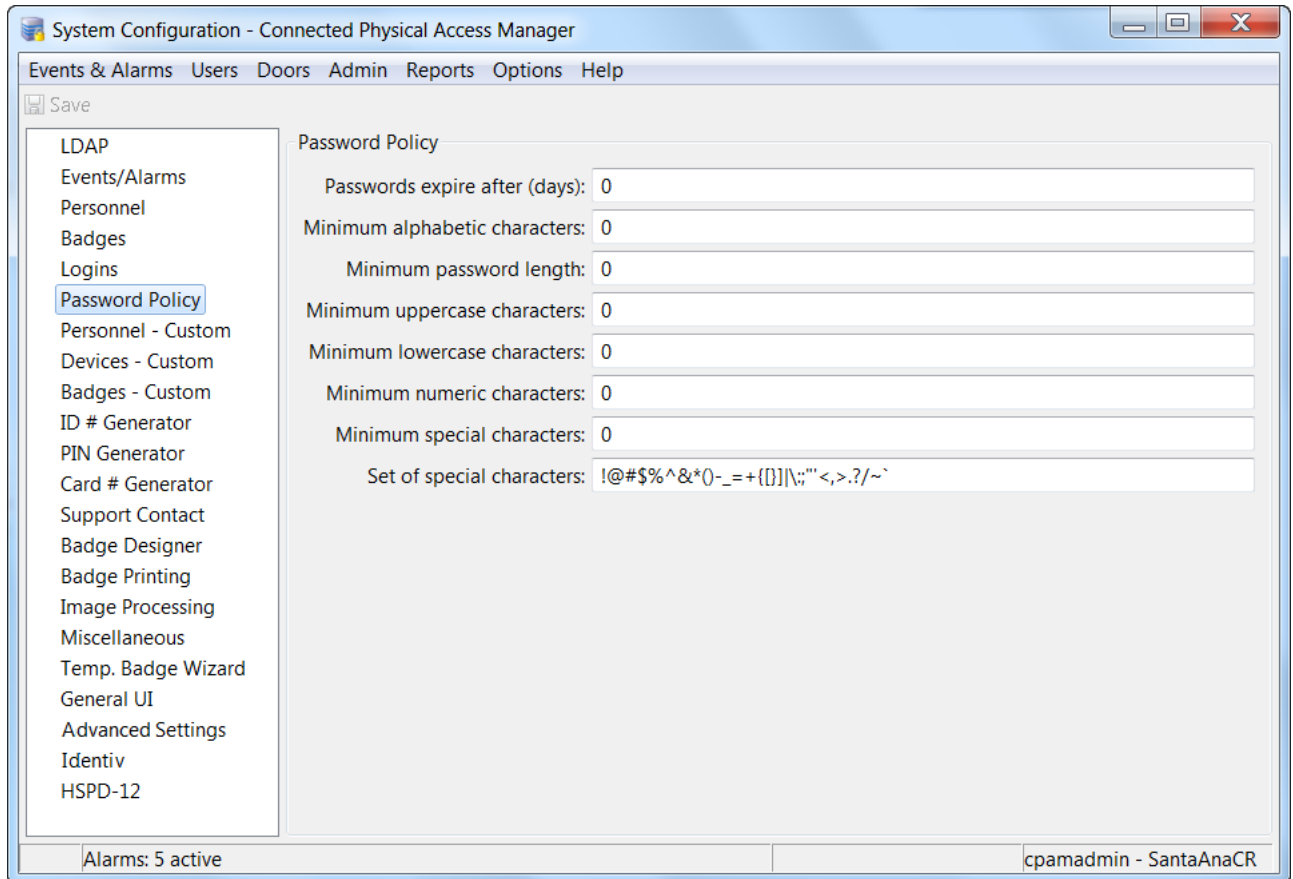

[Table 17-6](#) describes the fields and options on the **Password Policy** page.

**Table 17-6** Fields and Options on the System Configuration window's Password Policy page

| Field or Option                      | Description                                                               |
|--------------------------------------|---------------------------------------------------------------------------|
| <b>Passwords expire after (days)</b> | Passwords expire after this many days.                                    |
| <b>Minimum alphabetic characters</b> | Minimum number of a to z characters or A to Z characters in the password. |
| <b>Minimum password length</b>       | Minimum number of characters in the password.                             |
| <b>Minimum uppercase characters</b>  | Minimum number of uppercase password characters.                          |
| <b>Minimum lowercase characters</b>  | Minimum number of lowercase password characters.                          |
| <b>Minimum numeric characters</b>    | Minimum number of numeric password characters.                            |

Table 17-6 Fields and Options on the System Configuration window's Password Policy page (continued)

| Field or Option             | Description                                                      |
|-----------------------------|------------------------------------------------------------------|
| Minimum special characters  | Minimum number of special characters in the set specified below. |
| Set of "special" characters | Which characters qualify as special characters for the above.    |

**Note**

Changes to system configuration settings do not take effect until you log out (select **Logout** from the **Options** menu) and log back in to the ICPAM application.

## Personnel - Custom page of the System Configuration window

The **Personnel - Custom** page of the System Configuration window (shown in [Figure 17-7](#)) provides settings that define the custom fields available in the personnel detail window. See [Table 17-7](#) for descriptions of the fields and options on this page.

Figure 17-7 Personnel - Custom page of the System Configuration window

System Configuration - Connected Physical Access Manager

Events & Alarms Users Doors Admin Reports Options Help

Save

LDAP  
Events/Alarms  
Personnel  
Badges  
Logins  
Password Policy  
**Personnel - Custom**  
Devices - Custom  
Badges - Custom  
ID # Generator  
PIN Generator  
Card # Generator  
Support Contact  
Badge Designer  
Badge Printing  
Image Processing  
Miscellaneous  
Temp. Badge Wizard  
General UI  
Advanced Settings  
Identiv  
HSPD-12

Personnel - Custom

[0] Personnel Custom Field 0

Attributes

Enabled

Custom field type:

Custom field tab:

order: 0

Column header: Custom Field 0

Form label: Custom field 0

Alarms: 5 active

cpamadmin - SantaAnaCR

Table 17-7 describes the fields and options on the **Personnel - Custom** page.

*Table 17-7 Fields and Options on the System Configuration window's Personnel - Custom page*

| Field or Option               | Description                                                                                                                                                                                                                                                              |
|-------------------------------|--------------------------------------------------------------------------------------------------------------------------------------------------------------------------------------------------------------------------------------------------------------------------|
| <b>Custom Personnel Field</b> | Selects which of the available custom fields is to be viewed or edited.                                                                                                                                                                                                  |
| <b>Enabled</b>                | Select the check box to enable the selected custom field.                                                                                                                                                                                                                |
| <b>Custom field type</b>      | Displays the type of the custom field value (Example: Text, URL) to be associated with a custom field tab, and displays the selected type in the personnel and badges modules.                                                                                           |
| <b>Custom field tab</b>       | Displays the custom field tab names in a drop-down list.<br>To create more custom field tabs, refer to <a href="#">Custom Field Tabs, page 17-16</a> .                                                                                                                   |
| <b>Order</b>                  | Displays custom personal fields in numerical order in the personnel module custom field.                                                                                                                                                                                 |
| <b>Column header</b>          | Changes the name of the column header of the selected custom field. The column header is displayed in list view columns. To be consistent with the rest of the application, this would be capitalized such as the title of a book, for example: Driver's License Number. |
| <b>Form label</b>             | Changes the name of the form label of the selected custom field. The form label is displayed in detail window fields. To be consistent with the rest of the application, this would be capitalized like the a sentence, for example: Driver's license number.            |



**Note**

Changes to system configuration settings do not take effect until you log out (select **Logout** from the **Options** menu) and log back in to the ICPAM application.

## Custom Field Tabs

The **Personnel - Custom** page includes a 'Custom field tab' drop-down list, which shows the tabs created using the Custom Field Tabs option.

To define a new tab, follow this procedure:

- 
- Step 1** From the **Admin** menu, select **Custom Field Tabs**.
- Step 2** In the resulting **Custom Field Tabs** window, click **Add...**

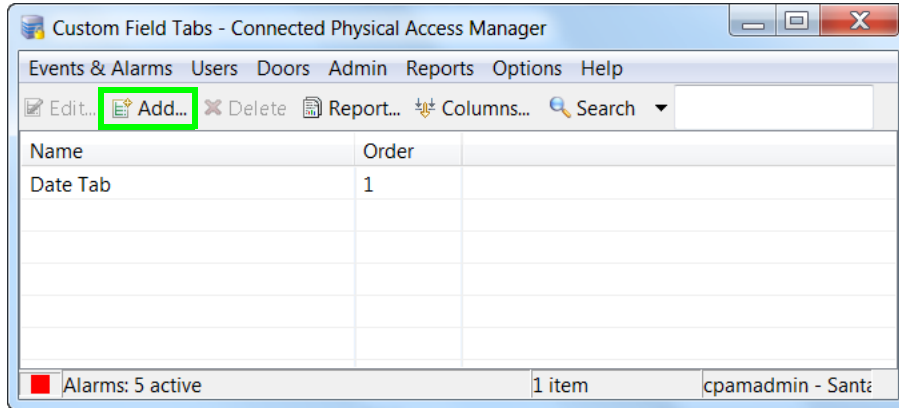

The **Add Custom Tab** dialog appears.

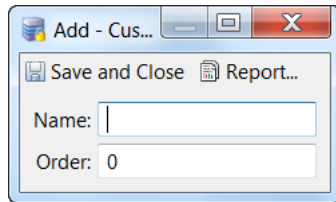

- Step 3** Type a name for this new tab, and specify the order in which it is to be displayed in the option list (where 0 is the top of the list).
- Step 4** Click **Save and Close**.
-



## Devices - Custom page of the System Configuration window

The **Devices - Custom** page of the System Configuration window (shown in [Figure 17-8](#)) provides settings that define the custom fields available in the device detail window. See [Table 17-8](#) for descriptions of the fields and options on this page.

*Figure 17-8 Devices - Custom page of the System Configuration window*

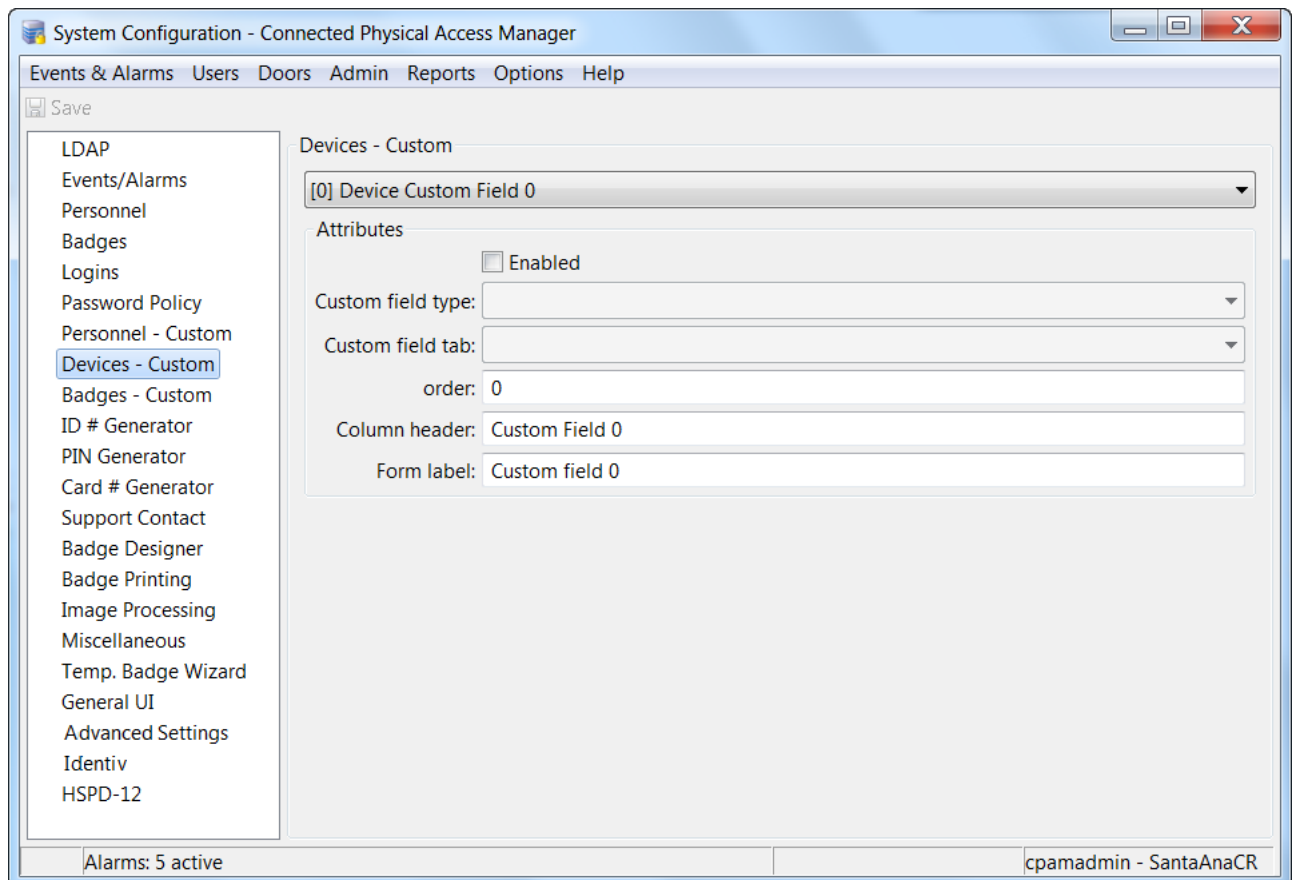

[Table 17-8](#) describes the fields and options on the **Devices - Custom** page.

*Table 17-8 Fields and Options on the System Configuration window's Devices - Custom page*

| Field or Option             | Description                                                                  |
|-----------------------------|------------------------------------------------------------------------------|
| <b>Custom Device Fields</b> | Selects which of the available custom fields is to be viewed or edited.      |
| <b>Enabled</b>              | Select the check box to enable the selected custom field.                    |
| <b>Drop down</b>            | Select the check box to use a drop-down for entry the selected custom field. |

Table 17-8 Fields and Options on the System Configuration window's Devices - Custom page (continued)

| Field or Option      | Description                                                                                                                                                                                                                                                |
|----------------------|------------------------------------------------------------------------------------------------------------------------------------------------------------------------------------------------------------------------------------------------------------|
| <b>Column header</b> | Change the name of the column header of the selected custom field. The column header is displayed in list view columns. To be consistent with the rest of the application, this would be capitalized like the title of a book, for example, Serial Number. |
| <b>Form label</b>    | Change the name of the form label of the selected custom field. The form label is displayed in detail window fields. To be consistent with the rest of the application, this would be capitalized like the a sentence, for example, Serial number.         |

**Note**

Changes to system configuration settings do not take effect until you log out (select **Logout** from the **Options** menu) and log back in to the ICPAM application.

## Badges - Custom page of the System Configuration window

The **Badges - Custom** page of the System Configuration window (shown in [Figure 17-9](#)) provides settings that define the custom fields available in the badge detail window. See [Table 17-9](#) for descriptions of the fields and options on this page.

*Figure 17-9 Badges - Custom page of the System Configuration window*

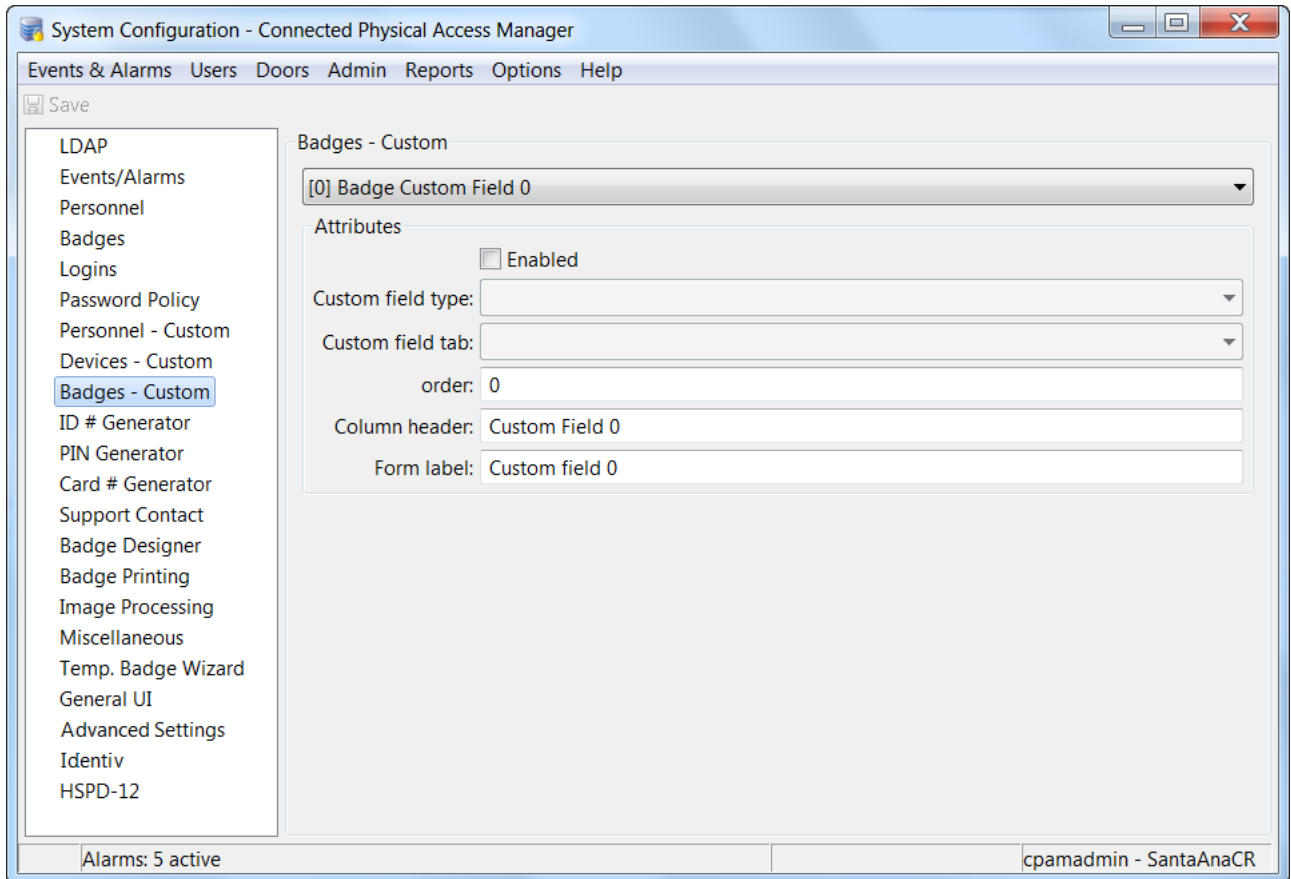

[Table 17-9](#) describes the fields and options on the **Badges - Custom** page.

*Table 17-9 Fields and Options on the System Configuration window's Badges - Custom page*

| Field or Option            | Description                                                                                                                                                                                       |
|----------------------------|---------------------------------------------------------------------------------------------------------------------------------------------------------------------------------------------------|
| <b>Custom Badge Fields</b> | Selects which of the available custom fields is to be viewed or edited.                                                                                                                           |
| <b>Enabled</b>             | Select the check box to enable the selected custom field.                                                                                                                                         |
| <b>Custom field type</b>   | Added custom field tab value is displayed in "custom field tab" drop down list of personal module and badge module.                                                                               |
| <b>Custom field tab</b>    | Add Custom field tabs value in custom field tabs window<br>(Example: <b>Admin</b> > <b>Custom Field</b> tabs > <b>Add</b> ) to display custom field tab value in personal module and badge module |

Table 17-9 Fields and Options on the System Configuration window's Badges - Custom page (continued)

| Field or Option      | Description                                                                                                                                                                                                                                                 |
|----------------------|-------------------------------------------------------------------------------------------------------------------------------------------------------------------------------------------------------------------------------------------------------------|
| <b>Order</b>         | Displays custom personal fields in order in the personnel module custom field.                                                                                                                                                                              |
| <b>Column header</b> | Changes the name of the column header of the selected custom field. The column header is displayed in list view columns. To be consistent with the rest of the application, this would be capitalized like the title of a book, for example: Serial Number. |
| <b>Form label</b>    | Changes the name of the form label of the selected custom field. The form label is displayed in detail window fields. To be consistent with the rest of the application, this would be capitalized like the a sentence, for example: Serial number.         |

**Note**

Changes to system configuration settings do not take effect until you log out (select **Logout** from the **Options** menu) and log back in to the ICPAM application.

# ID Number Generator page of the System Configuration window

The **ID # Generator** page of the System Configuration window (shown in [Figure 17-10](#)) provides settings for the optional ID number generator, which can be used to generate random personnel ID numbers (instead of using pre-existing ID numbers such as an employee ID number or a Social Security Number). See [Table 17-10](#) for descriptions of the fields and options on this page.

**Figure 17-10** ID Number Generator page of the System Configuration window

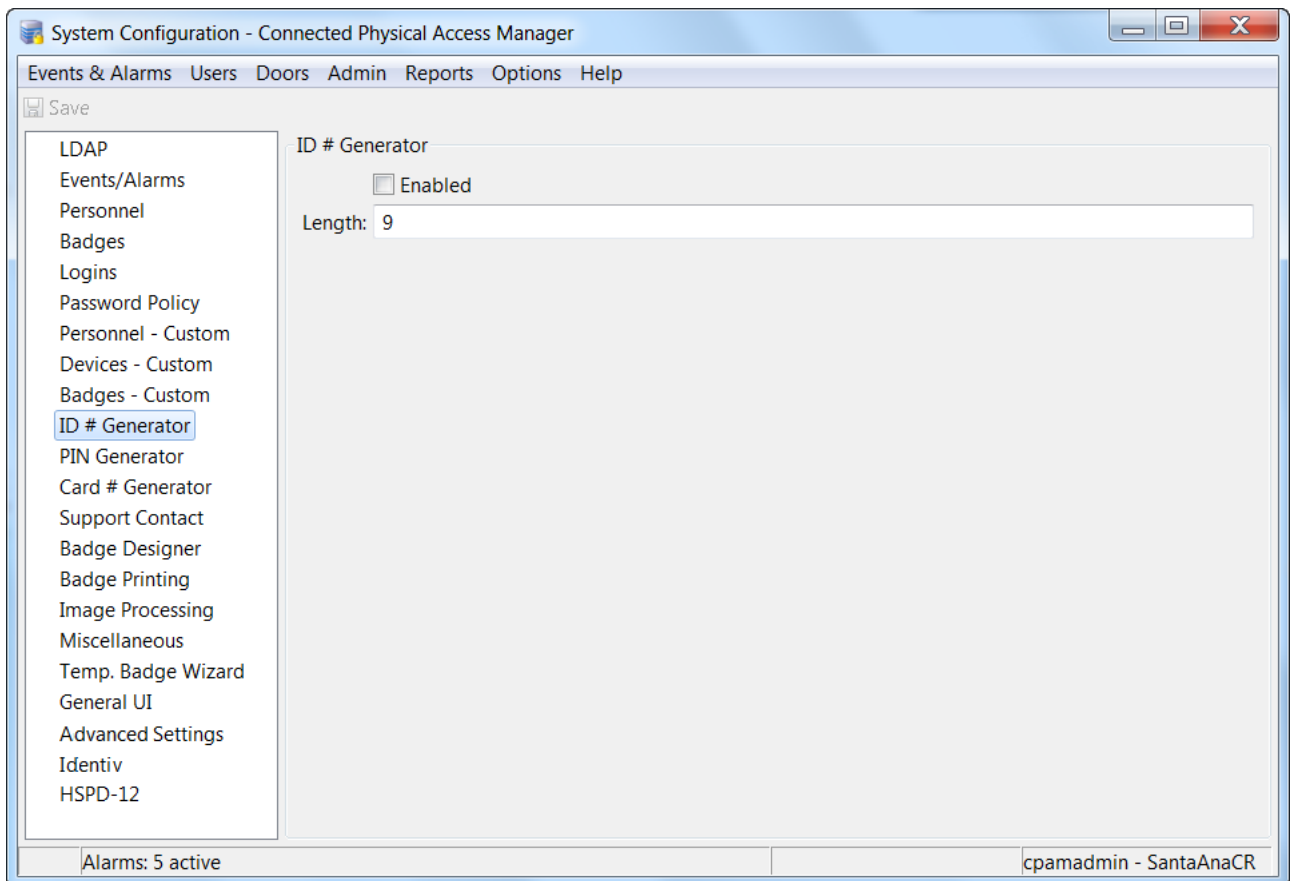

[Table 17-10](#) describes the fields and options on the **ID Number Generator** page.

**Table 17-10** Fields and Options on the System Configuration window's ID Number Generator page

| Field or Option | Description                                                                                                                    |
|-----------------|--------------------------------------------------------------------------------------------------------------------------------|
| <b>Enabled</b>  | Enables the personnel ID number generator. New personnel entries will have randomly generated ID numbers entered in the field. |
| <b>Length</b>   | The digit length of generated IDs.                                                                                             |

**Note**

Changes to system configuration settings do not take effect until you log out (select **Logout** from the **Options** menu) and log back in to the ICPAM application.

## PIN Generator page of the System Configuration window

The **PIN Generator** page of the System Configuration window (shown in [Figure 17-11](#)) provides settings for the optional personnel identification number generator, which can be used to generate random personnel ID numbers for badges. See [Table 17-11](#) for descriptions of the fields and options on this page.

*Figure 17-11 PIN Generator page of the System Configuration window*

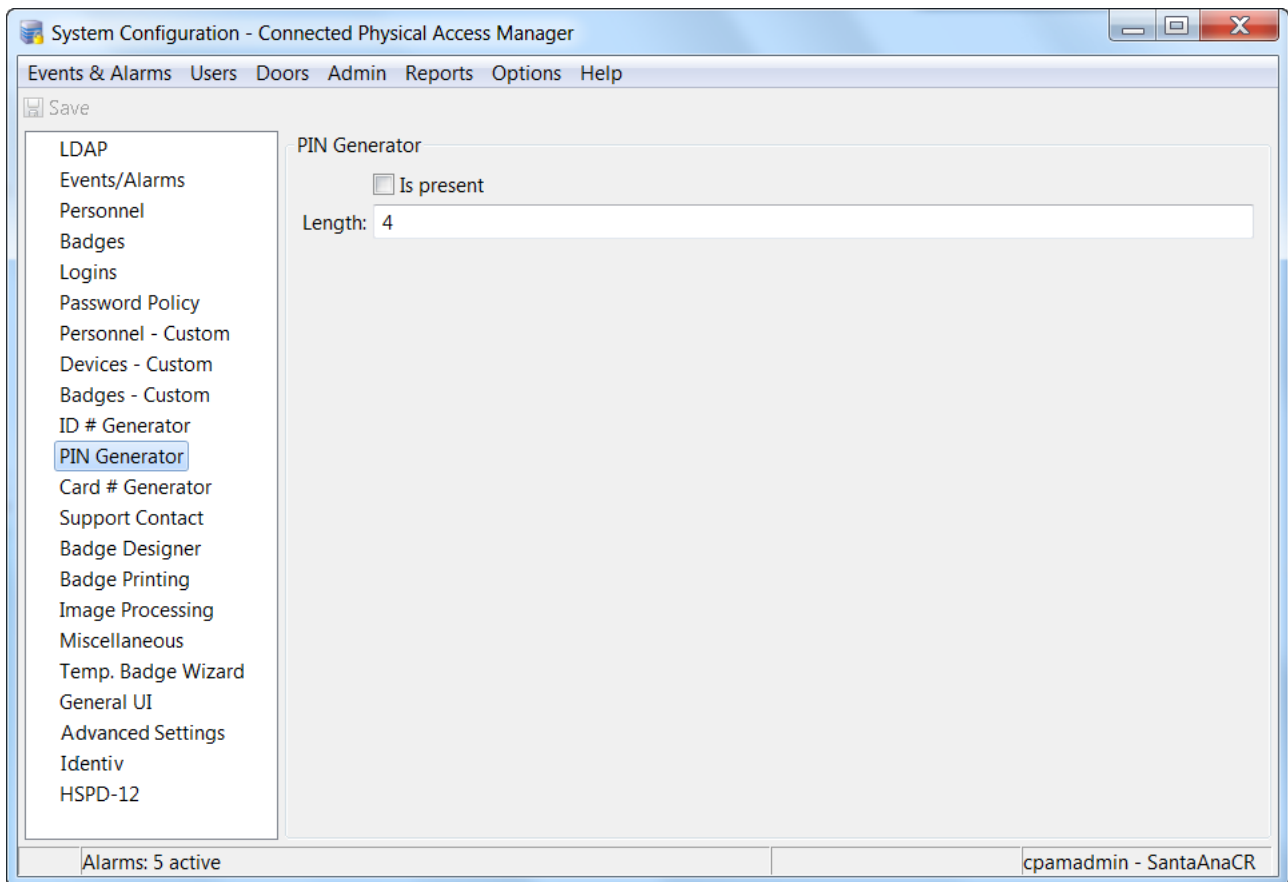

[Table 17-11](#) describes the fields and options on the **PIN Generator** page.

*Table 17-11 Fields and Options on the System Configuration window's PIN Generator page*

| Field or Option   | Description                                                                                                                  |
|-------------------|------------------------------------------------------------------------------------------------------------------------------|
| <b>Is Present</b> | Enable the personnel ID number generator. Adding new personnel will have randomly generated ID numbers entered in the field. |
| <b>Length</b>     | The number of digits in the generated PIN.                                                                                   |

**Note**

Changes to system configuration settings do not take effect until you log out (select **Logout** from the **Options** menu) and log back in to the ICPAM application.

## Card Number Generator page of the System Configuration window

The **Card # Generator** page of the System Configuration window (shown in [Figure 17-12](#)) provides settings for the optional card number generator, which can be used to generate card numbers between the specified values. See [Table 17-12](#) for descriptions of the fields and options on this page.

*Figure 17-12 Card Number Generator page of the System Configuration window*

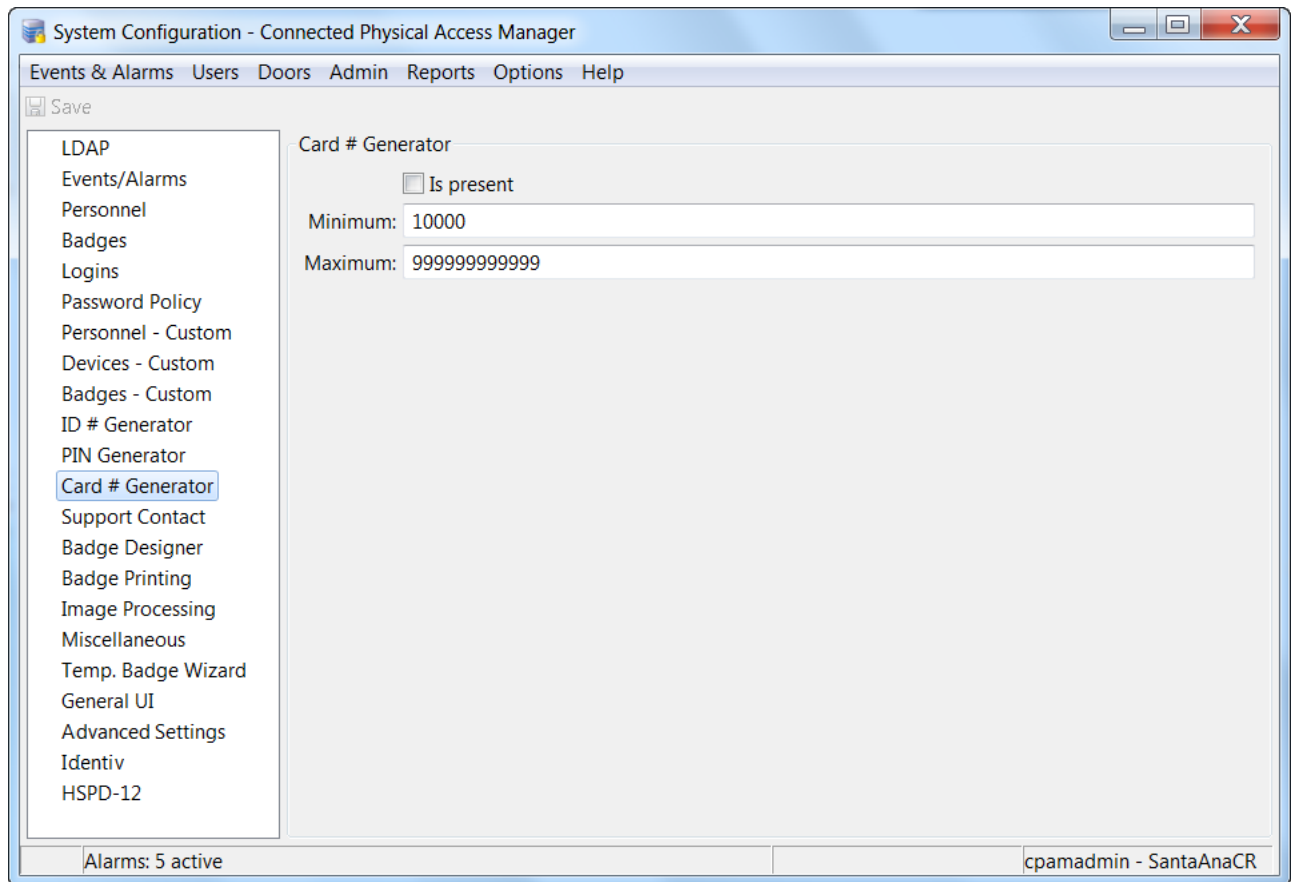

Table 17-12 describes the fields and options on the **Card Number Generator** page.

*Table 17-12 Fields and Options on the System Configuration window's Card Number Generator page*

| <b>Field or Option</b> | <b>Description</b>                                                                                                                 |
|------------------------|------------------------------------------------------------------------------------------------------------------------------------|
| <b>Is Present</b>      | Enables the card number generator. Adding new badges will have randomly generated card numbers entered in the <b>Card #</b> field. |
| <b>Minimum</b>         | Minimum value of the card number.                                                                                                  |
| <b>Maximum</b>         | Maximum value of the card number.                                                                                                  |



**Note**

Changes to system configuration settings do not take effect until you log out (select **Logout** from the **Options** menu) and log back in to the ICPAM application.



## Support Contact page of the System Configuration window

The **Support Contact** page of the System Configuration window (shown in [Figure 17-13](#)) provides settings for the support contact information which is displayed in the **About** window available from the **Help** menu. It is intended to be customized with the dealer/installer/integrator's contact information, because this is often the first contact for customer support. See [Table 17-13](#) for descriptions of the fields and options on this page.

*Figure 17-13 Support Contact page of the System Configuration window*

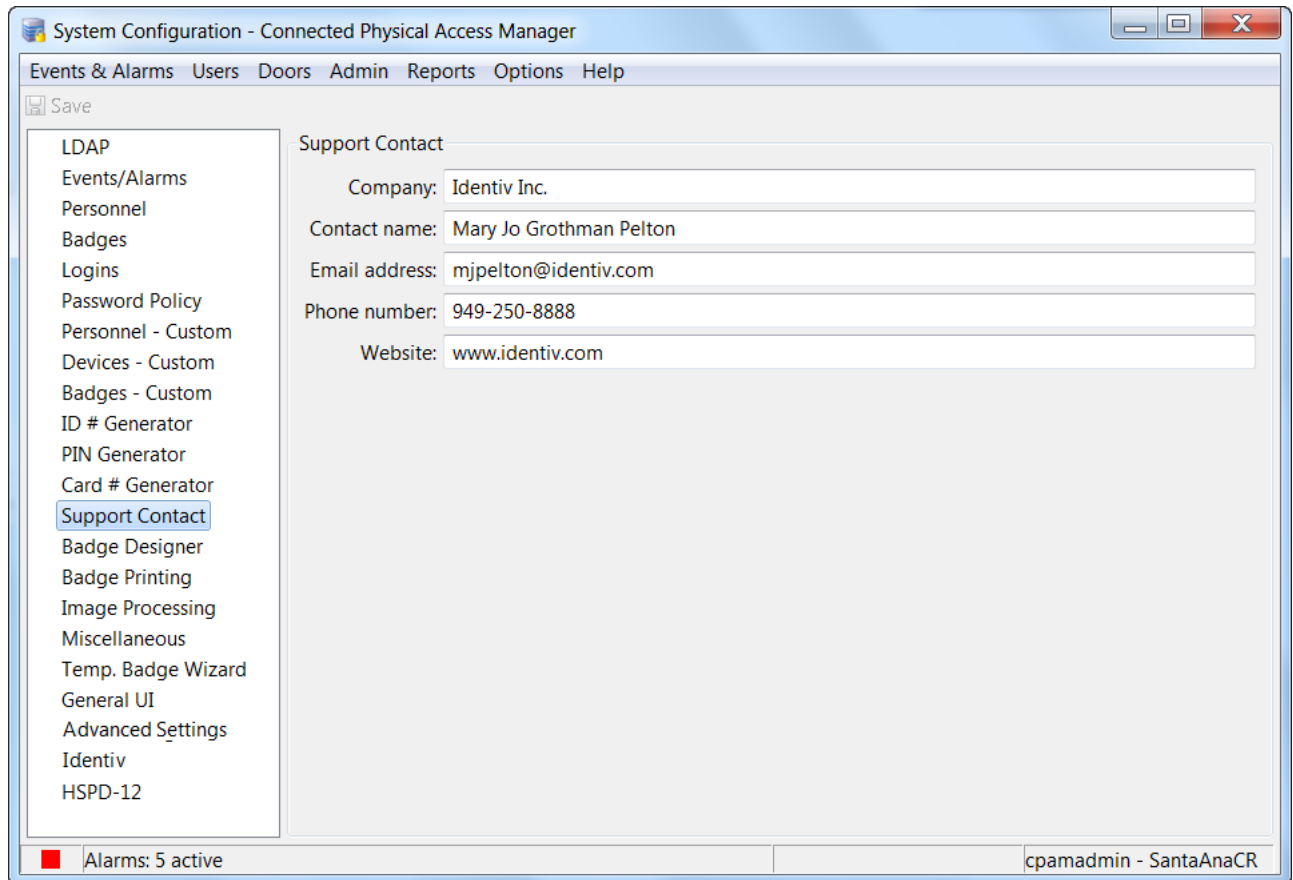

[Table 17-13](#) describes the fields and options on the **Support Contact** page.

*Table 17-13 Fields and Options on the System Configuration window's Support Contact page*

| Field or Option      | Description                            |
|----------------------|----------------------------------------|
| <b>Company</b>       | The support company's name.            |
| <b>Contact name</b>  | The name of the contact person.        |
| <b>Email address</b> | The contact person's email address.    |
| <b>Phone number</b>  | The contact person's phone number.     |
| <b>Website</b>       | The support company's Website address. |

**Note**

Changes to system configuration settings do not take effect until you log out (select **Logout** from the **Options** menu) and log back in to the ICPAM application.

## Badge Designer page of the System Configuration window

The **Badge Designer** page of the System Configuration window (shown in [Figure 17-14](#)) provides a table of all the fields included in the Badge Designer, so you can specify which ones to include or exclude from the list of available fields when a badge is created. See [Table 17-14](#) for descriptions of the fields and options on this page.

*Figure 17-14 Badge Designer page of the System Configuration window*

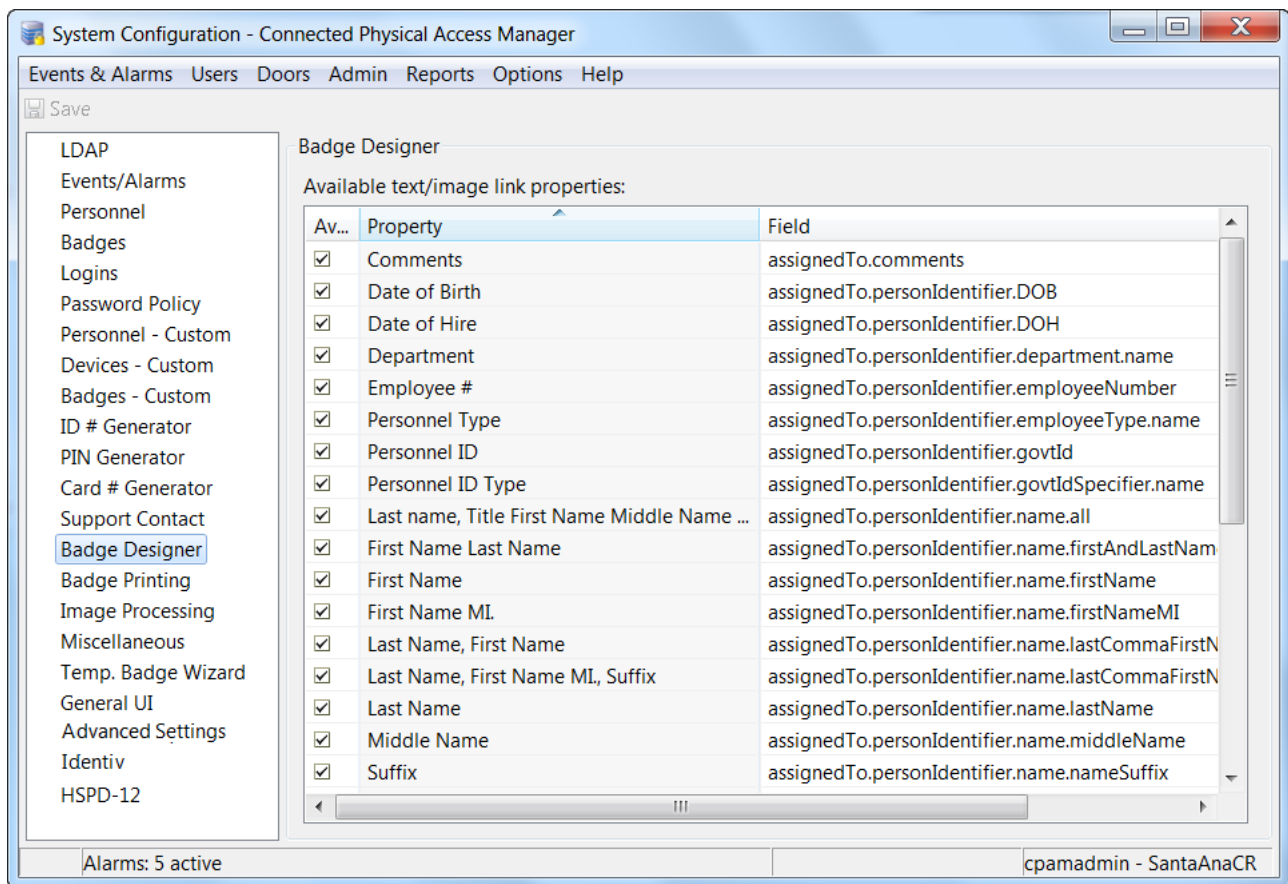

The three columns of the table on this page are:

*Table 17-14 Columns on the System Configuration window's Badge Designer page*

| <b>Column</b>    | <b>Description</b>                                                                                                                                                                                                                  |
|------------------|-------------------------------------------------------------------------------------------------------------------------------------------------------------------------------------------------------------------------------------|
| <b>Available</b> | Check this property to include this option in the list of available field options in the Badge Designer.<br>Uncheck this option to exclude this option from the list.<br>The default value is all options are checked and included. |
| <b>Property</b>  | The name of the option.                                                                                                                                                                                                             |
| <b>Field</b>     | The variables used to compute this field option.                                                                                                                                                                                    |



**Note**

Changes to system configuration settings do not take effect until you log out (select **Logout** from the **Options** menu) and log back in to the ICPAM application.

## Badge Printing page of the System Configuration window

The **Badge Printing** page of the System Configuration window (shown in [Figure 17-15](#)) provides options that enable you to determine which features and fields appear during the badge printing operation. See [Table 17-15](#) for descriptions of the fields and options on this page.

*Figure 17-15 Badge Printing page of the System Configuration window*

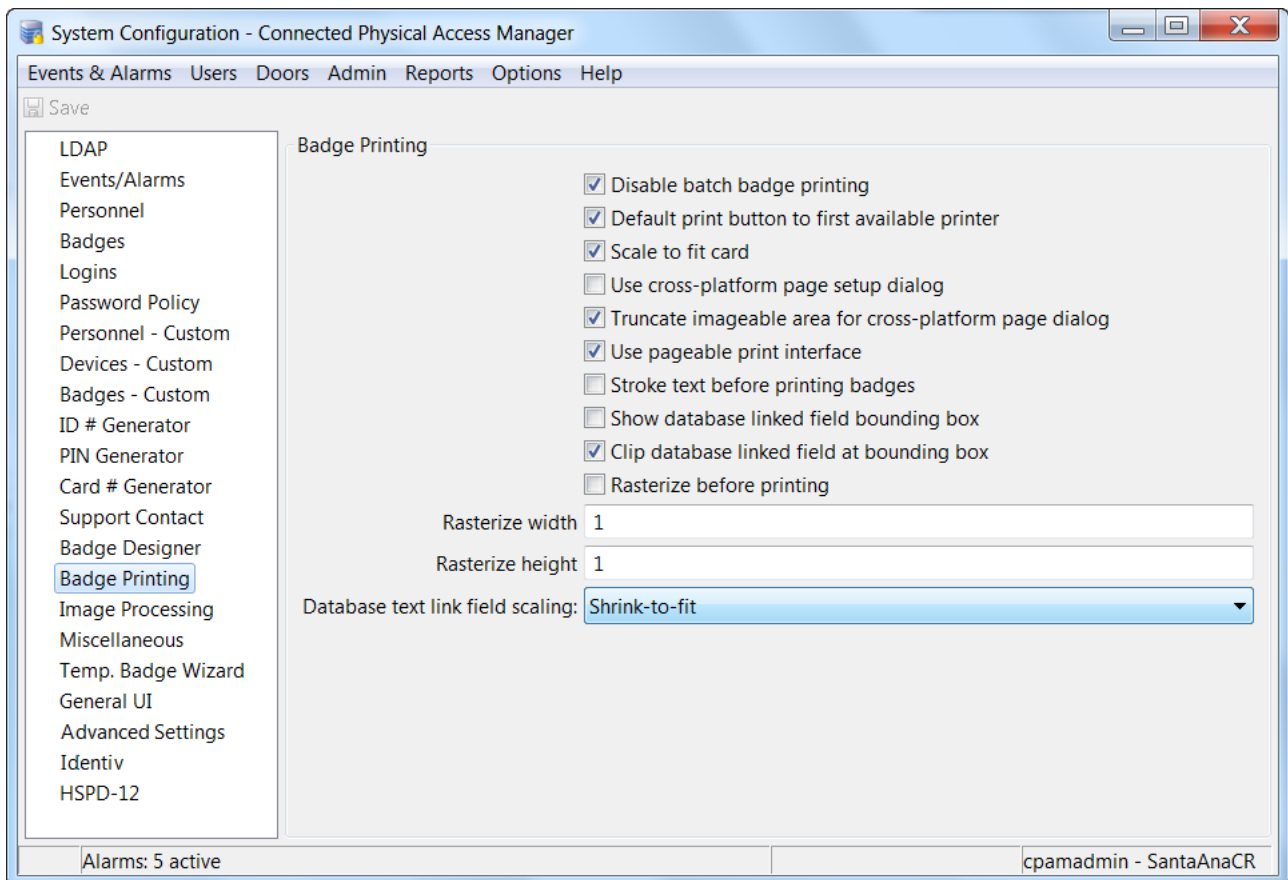

[Table 17-15](#) describes the fields and options on the **Badge Printing** page.

*Table 17-15 Fields and Options on the System Configuration window's Badge Printing page*

| Field or Option                                        | Description                                                                                                                         |
|--------------------------------------------------------|-------------------------------------------------------------------------------------------------------------------------------------|
| <b>Disable batch badge printing</b>                    | When checked, batch badge printing is not allowed.                                                                                  |
| <b>Default print button to first available printer</b> | When checked, the system defaults to the first available badge printer for printing a specified badge or badges.                    |
| <b>Scale to fit card</b>                               | When checked, the badge printer is instructed to scale the badge design and information to fit the size and dimensions of the card. |
| <b>Use cross-platform page setup dialog</b>            | When checked, the program uses a cross-platform setup dialog box when printing is requested.                                        |

Table 17-15 Fields and Options on the System Configuration window's Badge Printing page (continued)

| Field or Option                                               | Description                                                                                                                                 |
|---------------------------------------------------------------|---------------------------------------------------------------------------------------------------------------------------------------------|
| <b>Truncate imageable area for cross-platform page dialog</b> | When checked, the program will truncate the image area covered by the cross-platform page dialog box.                                       |
| <b>Use pageable print interface</b>                           | When checked, the program is instructed to use a pageable print interface.                                                                  |
| <b>Stroke text before printing badges</b>                     | When checked, the program is instructed to stroke the text before printing the badge.                                                       |
| <b>Show database linked field bounding box</b>                | When checked, the program displays the bounding box for any database link fields.                                                           |
| <b>Clip database linked field at bounding box</b>             | When checked, the program will clip the database instruction field at the bounding box. Any instructions behind this box will be truncated. |
| <b>Rasterize before printing</b>                              | When checked, the program will rasterize any badge images before printing.                                                                  |
| <b>Rasterize width</b>                                        | When the 'Rasterize before printing' option is checked, the width of the rasterized field is specified here.                                |
| <b>Rasterize height</b>                                       | When the 'Rasterize before printing' option is checked, the height of the rasterized field is specified here.                               |
| <b>Database text link field scaling</b>                       | Specify in this field the way in which the database text link field is scaled. The default is <b>Shrink-to-fit</b> .                        |

**Note**

Changes to system configuration settings do not take effect until you log out (select **Logout** from the **Options** menu) and log back in to the ICPAM application.

## Image Processing page of the System Configuration window

The **Image Processing** page of the System Configuration window (shown in [Figure 17-16](#)) provides options related to the processing of personnel ID photos and signature images. See [Table 17-16](#) for descriptions of the fields and options on this page.

**Figure 17-16** Image Processing page of the System Configuration window

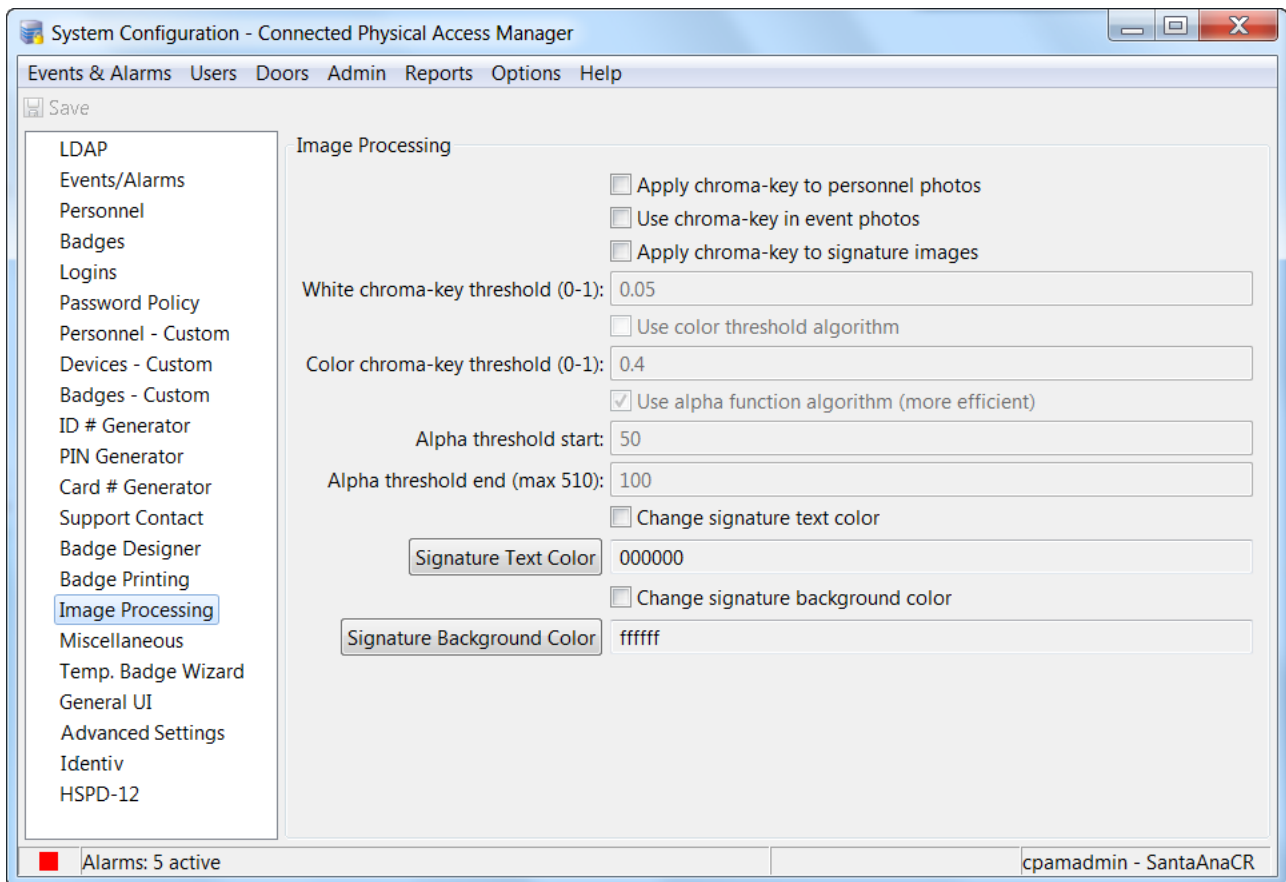

[Table 17-16](#) describes the fields and options on the **Image Processing** page.

**Table 17-16** Fields and Options on the System Configuration window's Image Processing page

| Field or Option                             | Description                                                                                                                  |
|---------------------------------------------|------------------------------------------------------------------------------------------------------------------------------|
| <b>Apply chroma-key to personnel photos</b> | When checked, the program applies chroma-key image processing to all personnel photos that are taken to the attached camera. |
| <b>Use chroma-key in event photos</b>       | When checked, the program uses chroma-key image processing to massage any event photos that are taken.                       |
| <b>Apply chroma-key to signature images</b> | When checked, the program uses chroma-key to process all signatures that are captured.                                       |
| <b>White chroma-key threshold</b>           | Specify the threshold value applied to white when using chroma-key processing.                                               |

Table 17-16 Fields and Options on the System Configuration window's Image Processing page (continued)

| Field or Option                          | Description                                                                                             |
|------------------------------------------|---------------------------------------------------------------------------------------------------------|
| <b>Color chroma-key threshold</b>        | Specify the threshold value applied to color when using chroma-key processing.                          |
| <b>Alpha threshold start</b>             | Specify the alpha threshold start value applied to images.                                              |
| <b>Alpha threshold end</b>               | Specify the alpha threshold stop value applied to images.                                               |
| <b>Change signature text color</b>       | When checked, the color of the signature can be changed as specified in the following field.            |
| <b>Signature text color</b>              | Specify the color that will be substituted for the captured signature color.                            |
| <b>Change signature background color</b> | When checked, the color of the signature background can be changed as specified in the following field. |
| <b>Signature background color</b>        | Specify the color that will be substituted for the captured signature background color.                 |

**Note**

Changes to system configuration settings do not take effect until you log out (select **Logout** from the **Options** menu) and log back in to the ICPAM application.

# Miscellaneous page of the System Configuration window

The **Miscellaneous** page of the System Configuration window (shown in [Figure 17-17](#)) provides options for various miscellaneous ICPAM features. See [Table 17-17](#) for descriptions of the fields and options on this page.

*Figure 17-17 Miscellaneous page of the System Configuration window*

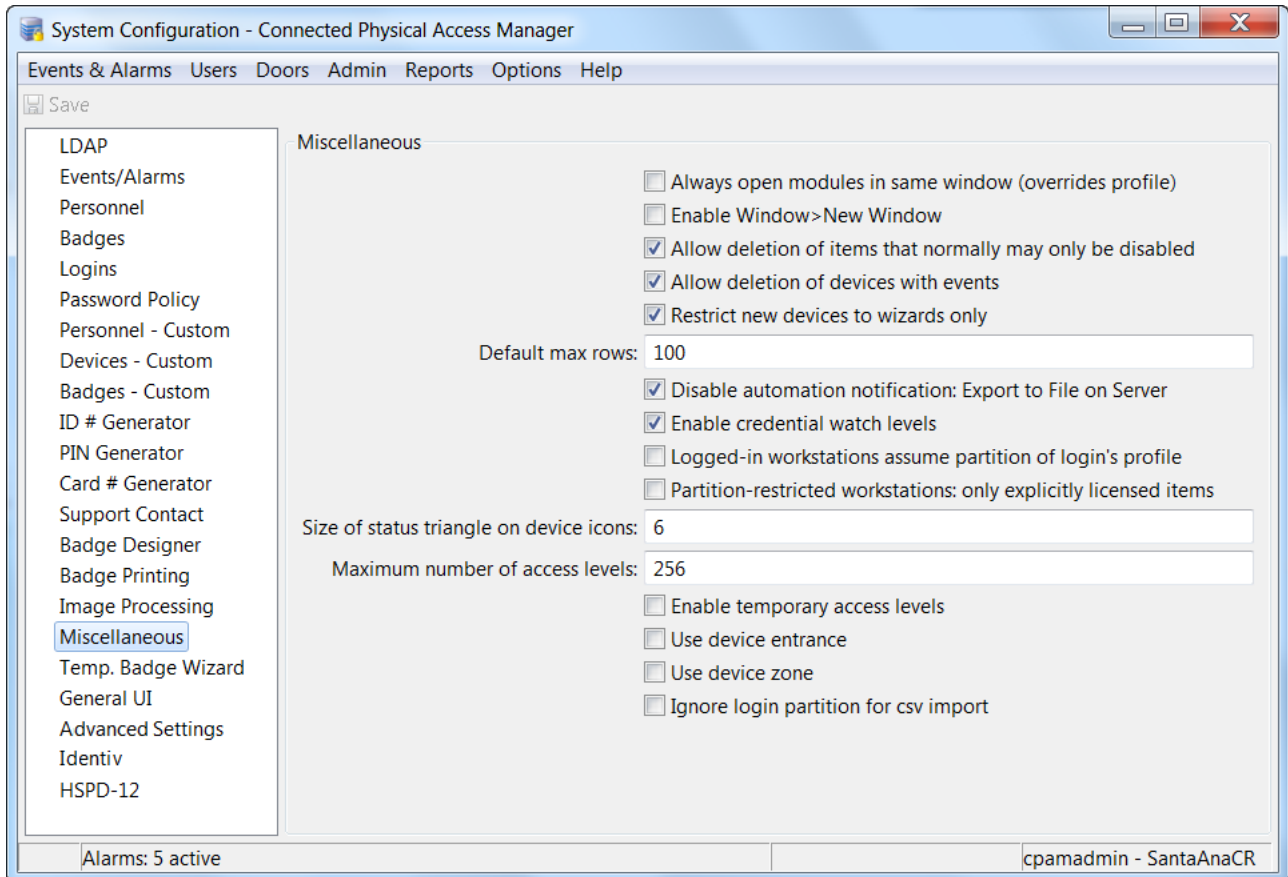

[Table 17-17](#) describes the fields and options on the **Miscellaneous** page.

*Table 17-17 Fields and Options on the System Configuration window's Miscellaneous page*

| Field or Option                               | Description                                                                                                       |
|-----------------------------------------------|-------------------------------------------------------------------------------------------------------------------|
| <b>Always open new modules in same window</b> | If checked, opening a new module simply replaces the module in the same window, rather than opening a new window. |
| <b>Enable Window &gt; New Window</b>          | Allows modules to be opened in multiple windows. Adds an additional <b>New Window</b> button to the toolbar.      |



Table 17-17 Fields and Options on the System Configuration window's Miscellaneous page (continued)

| Field or Option                                                                     | Description                                                                                                                                                                                                                                                                                                                                                                                                                                     |
|-------------------------------------------------------------------------------------|-------------------------------------------------------------------------------------------------------------------------------------------------------------------------------------------------------------------------------------------------------------------------------------------------------------------------------------------------------------------------------------------------------------------------------------------------|
| <b>Allow deletion of items that normally may only be disabled</b>                   | Enables a true delete option in some modules. Normally, important items should be disabled, not deleted. Even with this option enabled, only items that are not referenced by other items may be deleted. For example, if a device has an event occur for it, it may no longer be deleted, as the event references the device. This is because true deletion in this case would result in the inability to correctly report on any such events. |
| <b>Allow deletion of devices with events</b>                                        | Deletes events associated with a device when a device is deleted.<br><b>Note</b> Identiv recommends that you do not delete devices, because any events that are associated with the device will be deleted if the device is deleted.                                                                                                                                                                                                            |
| <b>Restrict new devices to wizards only</b>                                         | All new devices added to the <b>Hardware - Tree</b> module will use an add wizard.                                                                                                                                                                                                                                                                                                                                                              |
| <b>Default max rows</b>                                                             | Limits the number of visible rows in list-based modules such as Events and Badges. For example, if the default max rows is set to 100, the badges module displays a maximum of 100 rows.<br>Enter a number between 1 and 5000.                                                                                                                                                                                                                  |
| <b>Change queue buffer size</b>                                                     | Enter a new buffer size.                                                                                                                                                                                                                                                                                                                                                                                                                        |
| <b>Logged in workstations assume partition of login's profile</b>                   | Not supported in CPAM 1.4.1, CPAM 1.5.0, ICPAM 2.1, or ICPAM 2.2.                                                                                                                                                                                                                                                                                                                                                                               |
| <b>Partition-restricted workstations only use explicitly assigned license items</b> | Not supported in CPAM 1.4.1, CPAM 1.5.0, ICPAM 2.1, or ICPAM 2.2.                                                                                                                                                                                                                                                                                                                                                                               |



Note

Changes to system configuration settings do not take effect until you log out (select **Logout** from the **Options** menu) and log back in to the ICPAM application.

# Temporary Badge Wizard page of the System Configuration window

The **Temp. Badge Wizard** page of the System Configuration window (shown in [Figure 17-18](#)) provides settings that control the behavior of the Temporary Badge Wizard. See [Table 17-18](#) for descriptions of the fields and options on this page.

*Figure 17-18 Temporary Badge Wizard page of the System Configuration window*

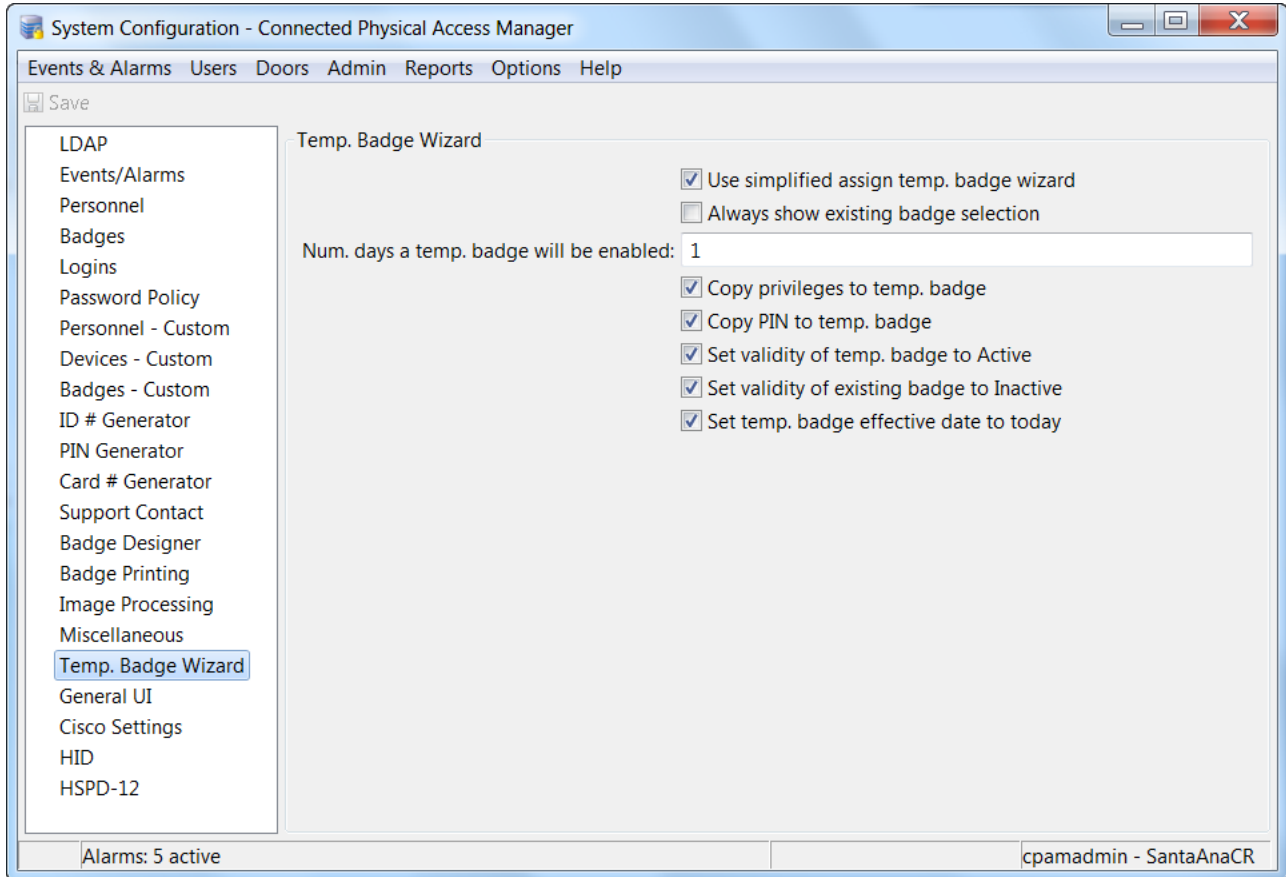

[Table 17-18](#) describes the fields and options on the **Temporary Badge Wizard** page.

*Table 17-18 Fields and Options on the System Configuration window's Temp Badge Wizard page*

| Field or Option                                 | Description                                                                                        |
|-------------------------------------------------|----------------------------------------------------------------------------------------------------|
| <b>Use simplified assign temp. badge wizard</b> | When checked, this program uses a shortened version of the temporary badge wizard.                 |
| <b>Always show existing badge selection</b>     | When checked, the wizard will always show the existing badge selection.                            |
| <b>Num. days a temp. badge will be enabled</b>  | Specify the number of days the wizard assigns a temporary badge before the program invalidates it. |

Table 17-18 Fields and Options on the System Configuration window's Temp Badge Wizard page (continued)

| Field or Option                                   | Description                                                                                                                                                   |
|---------------------------------------------------|---------------------------------------------------------------------------------------------------------------------------------------------------------------|
| <b>Copy privileges to temp. badge</b>             | When checked, the wizard allows privileges to be copied to a temporary badge.                                                                                 |
| <b>Copy PIN to temp. badge</b>                    | When checked, the wizard allows a PIN number to be copied to a temporary badge.                                                                               |
| <b>Set validity of temp. badge to Active</b>      | When checked, the wizard allows validity of a temporary badge to be set to active. Otherwise, the validity of the badge is inactive.                          |
| <b>Set validity of existing badge to Inactive</b> | When unchecked, the wizard allows the validity of an existing temporary badge to be set to active. Otherwise, the validity of the existing badge is inactive. |
| <b>Set temp. badge effective date to today</b>    | When checked, the wizard assumes all temporary badges are valid from the moment they are created.                                                             |

**Note**

Changes to system configuration settings do not take effect until you log out (select **Logout** from the **Options** menu) and log back in to the ICPAM application.

## General UI page of the System Configuration window

The **General UI** page of the System Configuration window (shown in [Figure 17-19](#)) provides options that define the default file type for specific categories of images (including maps, ID photos, other photos, and signatures). See [Table 17-19](#) for descriptions of the fields and options on this page.

*Figure 17-19 General UI page of the System Configuration window*

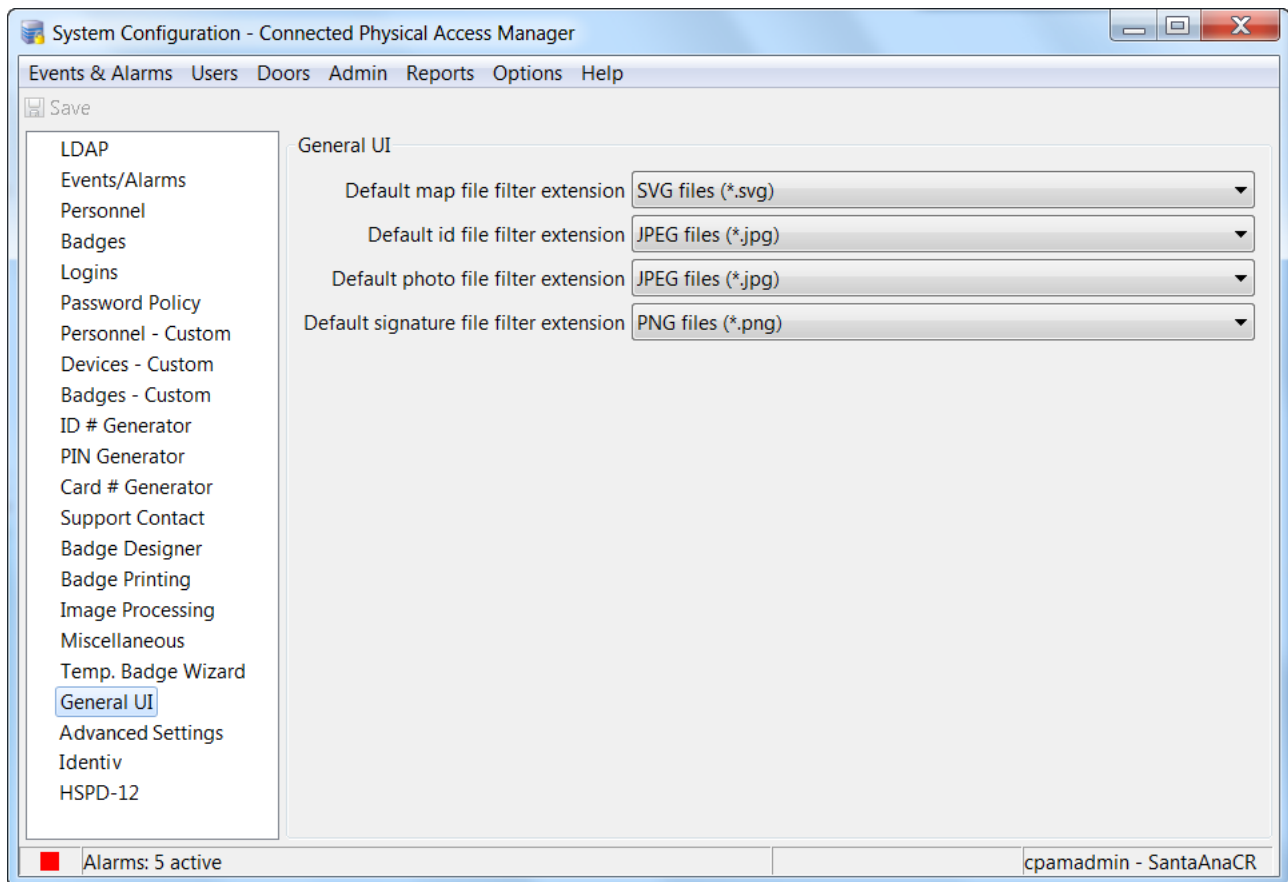

[Table 17-19](#) describes the fields and options on the **General UI** page.

*Table 17-19 Fields and Options on the System Configuration window's General UI page*

| Field or Option                                | Description                                                          |
|------------------------------------------------|----------------------------------------------------------------------|
| <b>Default map file filter extension</b>       | Specify the extension applied to the map file filter by default.     |
| <b>Default ID file filter extension</b>        | Specify the extension applied to an ID file filter by default.       |
| <b>Default photo file filter extension</b>     | Specify the extension applied to a photo file filter by default.     |
| <b>Default signature file filter extension</b> | Specify the extension applied to a signature file filter by default. |

**Note**

Changes to system configuration settings do not take effect until you log out (select **Logout** from the **Options** menu) and log back in to the ICPAM application.

## Advanced page of the System Configuration window

The **Advanced Settings** page of the System Configuration window (shown in [Figure 17-20](#)) provides options for various advanced ICPAM features. See [Table 17-20](#) for descriptions of the fields and options on this page.

*Figure 17-20* Advanced page of the System Configuration window

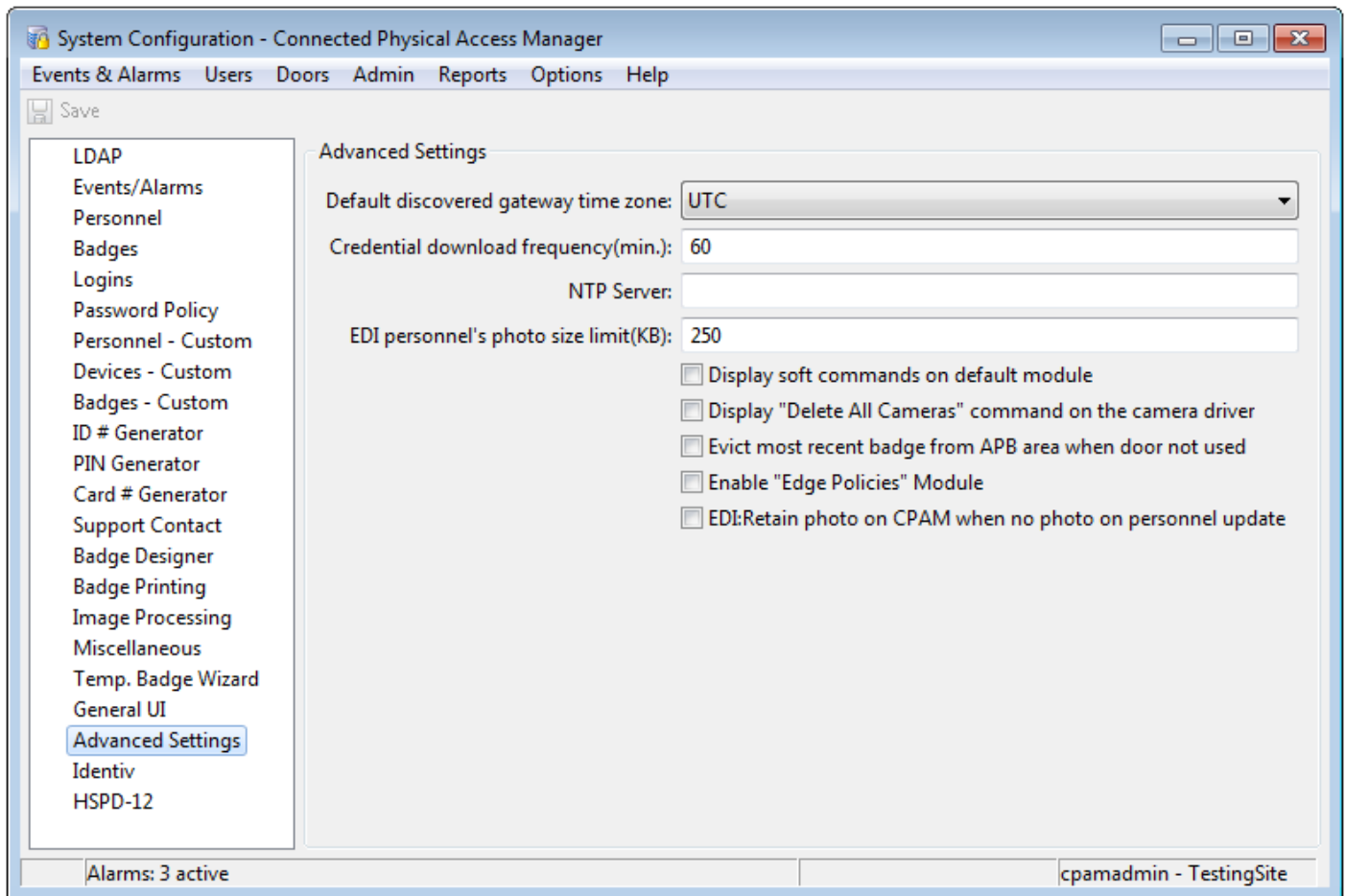
**Note**

As shown in the right-most column of the following table, to activate the changes made on this Advanced Settings page, sometimes you only need to log out and log back in to ICPAM, but other times you need to restart the ICPAM appliance. For information about restarting the ICPAM appliance, see [Using the Web Admin Menus, Commands, and Options, page 2-19](#), or ask your system administrator for assistance.

Table 17-20 describes the fields and options on the **Advanced** page.

**Table 17-20** Fields and Options on the System Configuration window's Advanced page

| Field or Option                                                  | Description                                                                                                                                                                                                                                                                                                                                                                                                                                                                                                                             | To Activate Changes:         |
|------------------------------------------------------------------|-----------------------------------------------------------------------------------------------------------------------------------------------------------------------------------------------------------------------------------------------------------------------------------------------------------------------------------------------------------------------------------------------------------------------------------------------------------------------------------------------------------------------------------------|------------------------------|
| <b>Default discovered gateway time zone</b>                      | Defines the time zone for all discovered gateways. This time zone is configured on all discovered gateways.                                                                                                                                                                                                                                                                                                                                                                                                                             | Restart the ICPAM appliance. |
| <b>Credential download frequency (min.)</b>                      | <p>Defines how often (in minutes) credential information is downloaded to the gateways.</p> <p><b>Note</b> You can also download credential changes immediately. Select <b>Hardware - Tree</b> from the <b>Doors</b> menu, right-click on the <b>Access GW Driver</b>, and select <b>Apply Credential Changes</b>. See <a href="#">Configuring Personnel, page 9-2</a> for more information.</p>                                                                                                                                        | Restart the ICPAM appliance. |
| <b>NTP Server</b>                                                | Defines a default Network Time Protocol (NTP) server when updating multiple gateways. See the " <a href="#">Changing the NTP Setting for Multiple Gateways</a> " section on page C-6.                                                                                                                                                                                                                                                                                                                                                   | Log out and log in.          |
| <b>EDI personnel's photo size limit (KB)</b>                     | <p>Defines the maximum file size for imported photo files using the System Configuration module. For example, if you enter a maximum file size of 500 KB, then any files larger than 500 KB will be automatically compressed when the personnel record is imported.</p> <ul style="list-style-type: none"> <li>Enter a value, in KB, between 50 and 750.</li> <li>The default value is 250 KB.</li> </ul> <p>See the "<a href="#">Understanding Photo File Compression When Importing Personnel Records</a>" section on page 14-12.</p> | Log out and log in.          |
| <b>Display soft commands on default module</b>                   | Displays the soft commands for the default m01 gateway module.                                                                                                                                                                                                                                                                                                                                                                                                                                                                          | Log out and log in.          |
| <b>Display "Delete All Cameras" command on the camera driver</b> | Displays the <b>Delete All Cameras</b> command for the Cisco VSM Video Driver in the Hardware - Tree module. See <a href="#">Deleting the Cisco VSM Cameras, page 15-29</a> .                                                                                                                                                                                                                                                                                                                                                           | Log out and log in.          |

Table 17-20 Fields and Options on the System Configuration window's Advanced page (continued)

| Field or Option                                                    | Description                                                                                                                                                                                                                                                                                                                                                                                                                                                                                                   | To Activate Changes:         |
|--------------------------------------------------------------------|---------------------------------------------------------------------------------------------------------------------------------------------------------------------------------------------------------------------------------------------------------------------------------------------------------------------------------------------------------------------------------------------------------------------------------------------------------------------------------------------------------------|------------------------------|
| <b>Evict most recent badge from APB area when door not used</b>    | If a user presents their badge and is granted access to an Anti-Passback Area, but decides not to enter the door, then a <i>Door Not Used</i> event is generated by the door's controller. To prevent the badge from being added to the Anti-Passback monitoring list, enable the System Configuration setting for <b>Evict most recent badge from APB area when door not used</b> .<br><br>See the <a href="#">“Evicting a Badge from APB if the User Does Not Enter the APB Area”</a> section on page 11-26 | Restart the ICPAM appliance. |
| <b>Enable “Edge Policies” Module</b>                               | Enables the Edge Policies module. See the <a href="#">“Configuring Edge Policies”</a> section on page 13-11.                                                                                                                                                                                                                                                                                                                                                                                                  | Log out and log in.          |
| <b>EDI: Retain photo on CPAM when no photo on personnel update</b> |                                                                                                                                                                                                                                                                                                                                                                                                                                                                                                               |                              |

**Note**

Changes to system configuration settings do not take effect until you log out (select **Logout** from the **Options** menu) and log back in to the ICPAM application.

## Identiv page of the System Configuration window

The **Identiv** page of the System Configuration window (shown in [Figure 17-21](#)) provides options for a few features related to Identiv EM-100 controllers. See [Table 17-21](#) for descriptions of the fields and options on this page.

**Figure 17-21** Identiv page of the System Configuration window

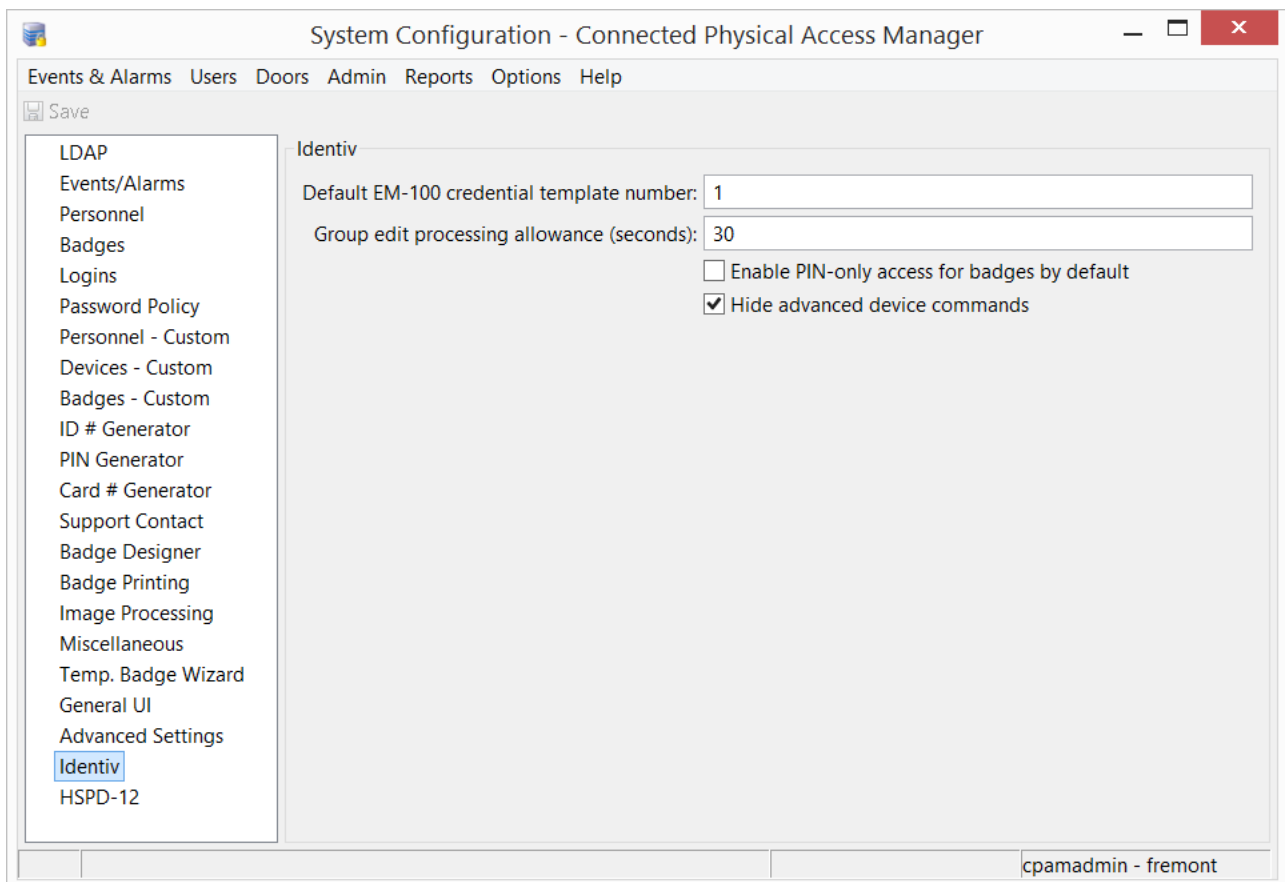

[Table 17-21](#) describes the fields and options on the **Identiv** page.

**Table 17-21** Fields and Options on the System Configuration window's Identiv page

| Field or Option                                     | Description                                                              |
|-----------------------------------------------------|--------------------------------------------------------------------------|
| <b>Default EM-100 credential template number</b>    | Enter the number of default credential templates.                        |
| <b>Group edit processing allowance (seconds)</b>    | Enter the time in seconds the program allows for processing group edits. |
| <b>Enable PIN-only access for badges by default</b> | Check this option to enable PIN-only access for issued badges.           |
| <b>Hide advanced device commands</b>                | Check this option to hide all advanced device commands.                  |



**Note**

Changes to system configuration settings do not take effect until you log out (select **Logout** from the **Options** menu) and log back in to the ICPAM application.

## HSPD-12 page of the System Configuration window

HSPD-12 is an acronym for **Homeland Security Presidential Directive 12**: Policy for a Common Identification Standard for Federal Employees and Contractors, which mandates a federal standard for secure and reliable forms of identification.

The **HSPD-12** page of the System Configuration window (shown in [Figure 17-22](#)) provides options related to HSPD-12. See [Table 17-22](#) for descriptions of the fields and options on this page.

*Figure 17-22 HSPD-12 page of the System Configuration window*

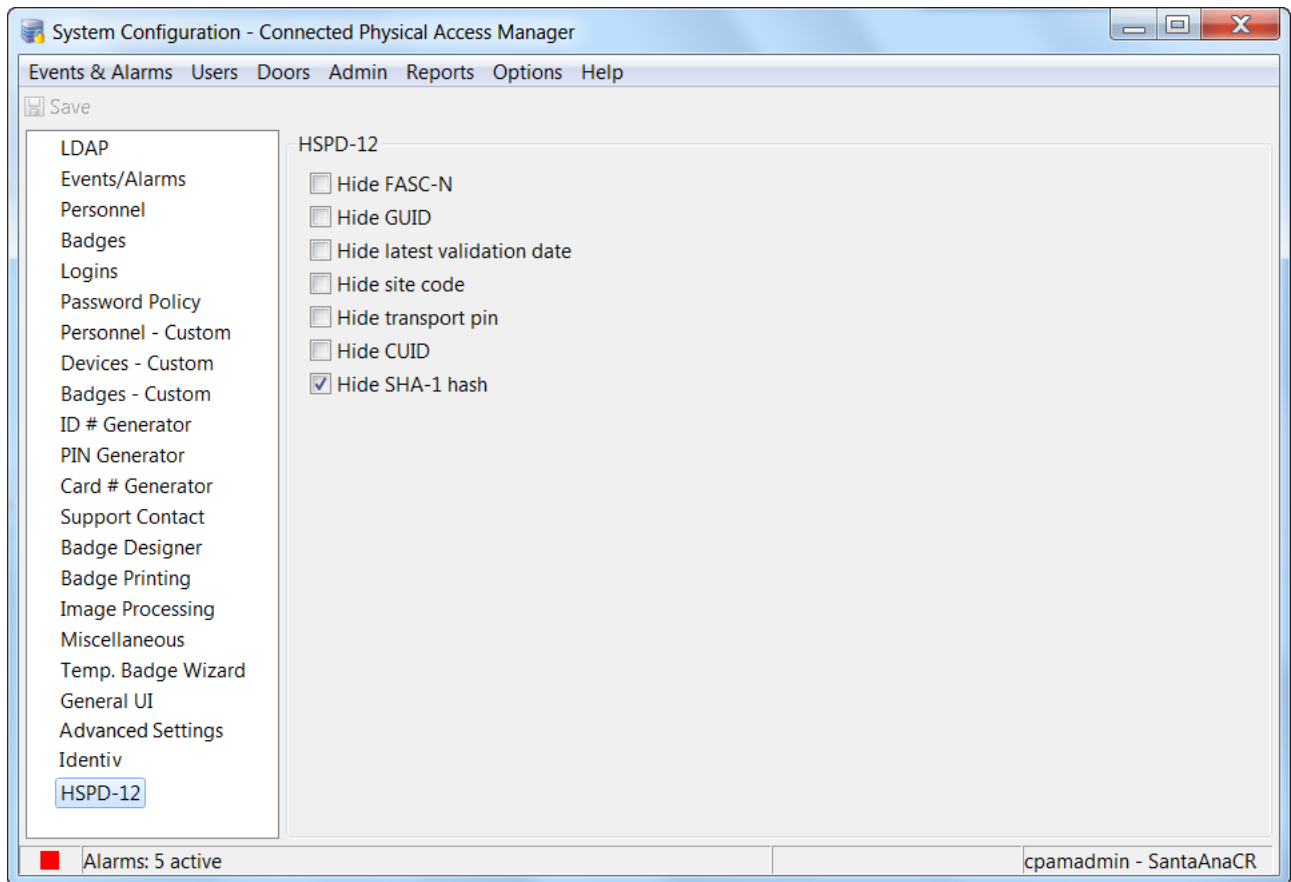

Table 17-22 describes the fields and options on the **HSPD-12** page.

*Table 17-22 Fields and Options on the System Configuration window's HSPD-12 page*

| <b>Field or Option</b>             | <b>Description</b>                                                  |
|------------------------------------|---------------------------------------------------------------------|
| <b>Hide FASC-N</b>                 | Check this option to hide FASC-N-related fields                     |
| <b>Hide GUID</b>                   | Check this option to hide GUID-related fields                       |
| <b>Hide latest validation date</b> | Check this option to hide the latest validation date for personnel. |
| <b>Hide site code</b>              | Check this option to hide the site code field.                      |
| <b>Hide transport pin</b>          | Check this option to hide the transport PIN field.                  |
| <b>Hide CUID</b>                   | Check this option to hide CUID-related fields.                      |
| <b>Hide SHA-1 hash</b>             | Check this option to hide any SHA-1 hashing from view.              |



**Note**

Changes to system configuration settings do not take effect until you log out (select **Logout** from the **Options** menu) and log back in to the ICPAM application.

## Backing Up and Restoring Data

---

This appendix describes how to backup and restore the ICPAM database.

Be sure to create at least one data backup during the initial server configuration, and another one after every upgrade. Data is backed up to a `.zip` file and automatically stored on the server disk drive. The file can also be downloaded to a workstation or network drive.

You can restore the data from a `.zip` archive only when the server is stopped.



Note

---

You must have at least one backup to restore the server software using the recovery CD. See [Reinstalling the ICPAM Server Software from a Recovery CD, page B-24](#) for more information.

---

### Contents

- [Backing up the ICPAM Database, page A-2](#)
  - [Backup Usage Notes, page A-2](#)
  - [Scheduling Automatic Backups, page A-3](#)
  - [Disabling Automatic Backups, page A-6](#)
  - [Performing a One-Time Manual Backup, page A-7](#)
- [Archiving the Historical Events Database, page A-9](#)
- [Restoring a Server Backup File, page A-9](#)

# Backing up the ICPAM Database

Use the backup option in the ICPAM Server Administration utility to back up all ICPAM data and configurations. Create at least one data backup during the initial server configuration, and another one after every upgrade. Data is backed up to a `.zip` file and automatically stored on the server disk drive. The file can also be downloaded to a workstation or network drive.

The following backup options are available:

- Backup all data, including live and historical events.
- Backup all data but exclude all events (do not back up events).
- Define an automatic backup schedule.
- Copy the automatic backups to a remote server.
- Perform a one-time manual backup.

Refer to the following topics:

- [Backup Usage Notes, page A-2](#)
- [Scheduling Automatic Backups, page A-3](#)
- [Disabling Automatic Backups, page A-6](#)
- [Performing a One-Time Manual Backup, page A-7](#)

## Backup Usage Notes

- The maximum size for a backup file is 1 gigabyte (GB) of data. An error occurs if the backup file will be larger than 1 GB, and the backup will fail.
- To reduce the size of the backup, you can do one or both of the following:
  - Exclude events from the backup operation. See the automatic and manual backup instructions in this section for more information.
  - Remove historical events from the database to reduce the size of the backup file. See the [“Archiving the Historical Events Database” section on page A-9](#) for more information. See the [“Archiving Historical Events” section on page 2-25](#) for instructions.
- The backup password is used to restore the backup file, if necessary. Record this password in a safe location.
- Manual backups are enabled only when automatic backups are disabled.
- Starting with the CPAM 1.2.0 release, data can be restored to a server with a different high-availability (HA) configuration. For example, data from a standalone server can be restored to a server in HA mode.
- To restore a backup in a high-availability (HA) configuration, stop both servers. The backup can be restored to either the active server or the standby server.

## Scheduling Automatic Backups

This section explains how to define automatic backups, including how to automatically save the backup files to a remote FTP or SFTP sever. [Figure A-1](#) shows the **Automatic Backup** page of the ICPAM Server Administration utility.

*Figure A-1 Automatic Backup page of the ICPAM Server Administration Utility*

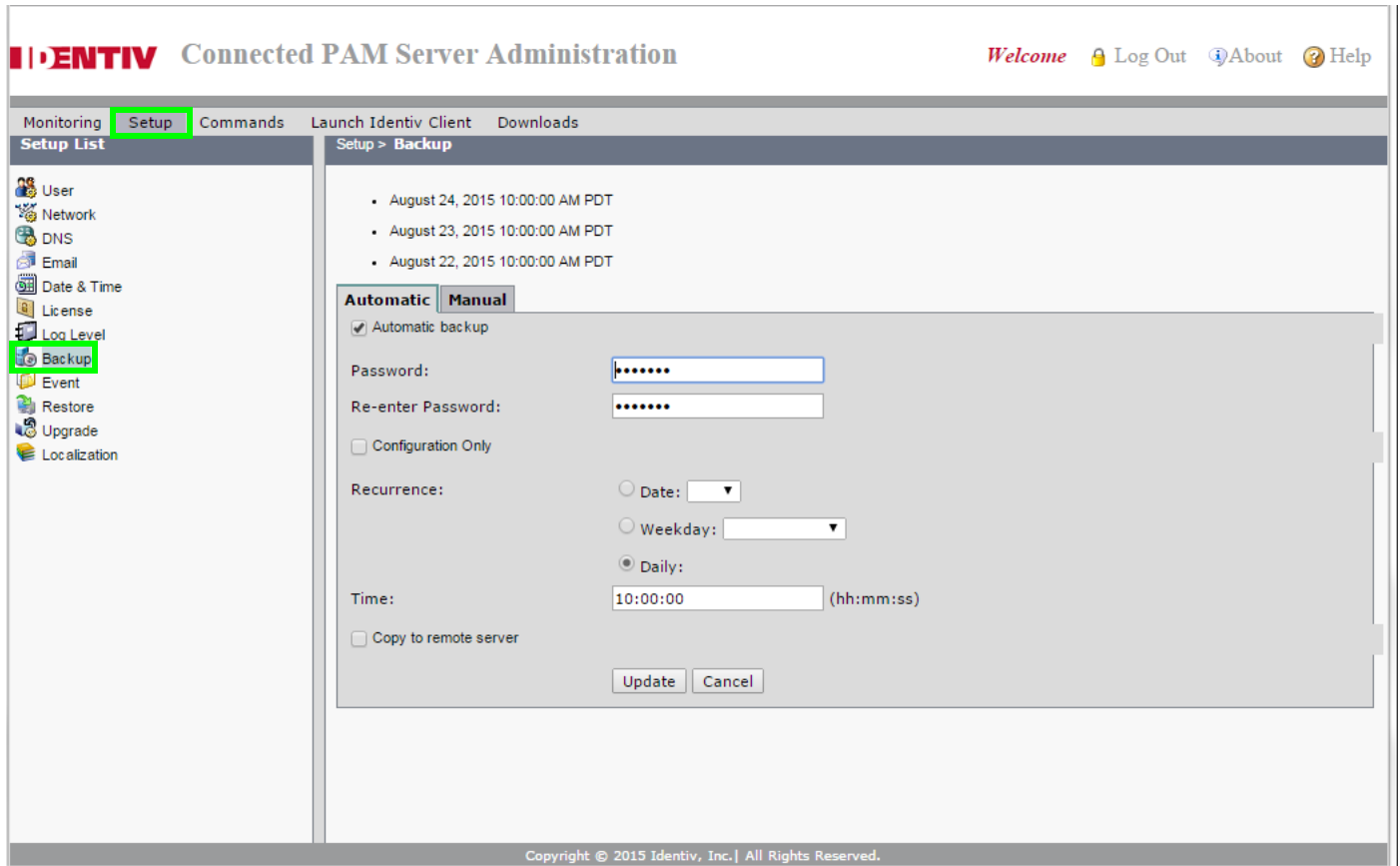

The three most recent backup files are listed at the top of the page. When a fourth backup file is added, the oldest file is deleted. You can right-click a filename to save it to a local or network drive, or use the option in the following procedure to automatically copy the backup files to a remote server.

The file name includes the date and the server software version number. For example:

- **bak-04122016-0933561.5.3\_0.3.6.cpam.noevents.zip** is the name of a no-events backup file created 4/12/2016 on a CPAM 1.5.3 system
- **bak-05242016-1452592.2.0\_0.3.8.ICPAM220.zip** is the name of a full backup file created 5/24/2016 on an ICPAM 2.2.0 system

### Procedure

To define automatic backups of the ICPAM data and configurations, do the following:

- Step 1** Log on to the ICPAM appliance, as described in [Logging on to the ICPAM Server Administration Utility, page 2-2](#).

- Step 2** Select **Setup** and then **Backup**, as shown by the green highlighting in [Figure A-1](#).
- Step 3** Select the **Automatic backup** check box.
- Step 4** Type and re-type a password for the backup file.  
If you need to use this backup file later to restore the data, this password must be entered at that time.
- Step 5** (Optional) To back up only the configuration data (and exclude the events), select the **Configuration Only** check box.
- Events will not be backed up and cannot be restored.
  - To remove historical events from the main database and reduce the size of the backup file, review the “[Archiving the Historical Events Database](#)” section on page A-9.
  - For instructions about how to prune old events from the main database, or how to remove them from the database by creating an archive of historical events, see the “[Archiving Historical Events](#)” section on page 2-25.
- Step 6** Define the automatic backup schedule.
- a. Specify the days when the backups will automatically occur:
    - To schedule backups for one day per month, select **Date** and then select the number for a day of the month.  
For example: 15.
    - To schedule backups once per week, select **Weekday** and then select a day of the week.  
For example: Tuesday.
    - To run backups every day, select **Daily**.
  - b. Specify the **Time** when the automatic backups will run.
    - Type the time in 24 hour format (hh:mm:ss).  
For example, to run backups at 2 p.m., enter 14:00:00. To run backups at 1 a.m., enter 01:00:00.
- Step 7** (Optional) Automatically copy the backups to a remote FTP or SFTP server.
- a. Check the **Copy to remote server** check box.  
The **remote server** settings appear, as shown in [Figure A-3 on page A-7](#).
  - b. Select the server protocol:
    - **FTP**: for standard File Transfer Protocol servers.
    - **SFTP**: for secure file transfers using the Secure File Transfer Protocol (also known as the SSH File Transfer Protocol).
  - c. Type the **IP Address** of the FTP or SFTP server.
  - d. Type the **Username** for the FTP or SFTP server account.
  - e. Type the **Password** for the FTP or SFTP server account.
  - f. Type the directory **Path** on the FTP or SFTP server where the backup should be saved. The path must exist on the remote server. If the directory is not available, the backup will fail.



**Note** If the IP address, username, password, or path is incorrect, or if the server is not available, then the backup is not copied to the remote server. The backup is still created on the ICPAM server.

- Step 8** Click **Update** to save the changes. Backups will occur according to the scheduled day(s) and time.
- When the backup is complete, the new backup file is added to the top of the screen, as shown in [Figure A-1](#).
    - The file name includes the date and the server software version number. For example:
      - **bak-04122016-0933561.5.3\_0.3.6.cpam.noevents.zip** is the name of a no-events backup file created 4/12/2016 on a CPAM 1.5.3 system
      - **bak-05242016-1452592.2.0\_0.3.8.ICPAM220.zip** is the name of a full backup file created 5/24/2016 on an ICPAM 2.2.0 system
    - Only the three most recent backup files are saved to the ICPAM server. When a fourth backup file is added, the oldest file is deleted.
    - To manually save the backup file to another location, right-click the filename and select a save option from the browser menu.
  - If the backup is copied to a remote server, a copy of the file is saved to the server location configured in [Step 7](#).
    - If the remote server settings are incorrect or the directory path does not exist, the file is not copied and an error message is displayed.
    - The backup is still saved to the ICPAM server even if the remote server is unavailable.
-

## Disabling Automatic Backups

To disable automatic backups, deselect the **Automatic backup** check box (Figure A-2).

Figure A-2 Disabling Automatic Backups

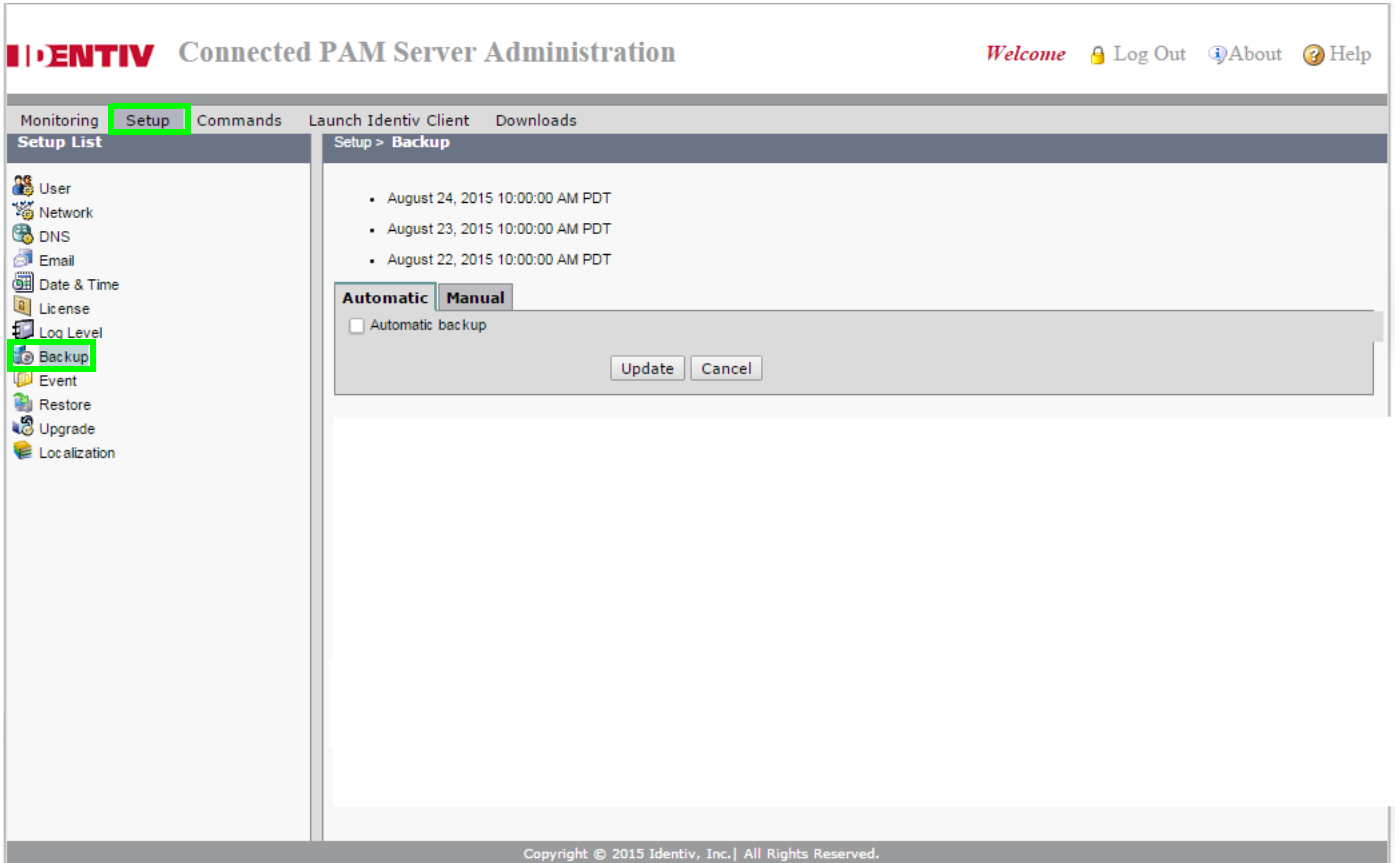

### Procedure

- Step 1 Log on to the ICPAM appliance as described in [Logging on to the ICPAM Server Administration Utility, page 2-2](#).
- Step 2 Select **Setup** and then **Backup**, as shown by the green highlighting in [Figure A-2](#).
- Step 3 Select the **Automatic** tab.
- Step 4 Deselect the **Automatic backup** check box.
- Step 5 Click **Update**.
- Step 6 (Optional) If necessary, perform a manual backup. See the “[Performing a One-Time Manual Backup](#)” section on page A-7.



## Performing a One-Time Manual Backup

This section explains how to perform a one-time manual backup, including how to save the backup file to a remote FTP or SFTP sever. [Figure A-3](#) shows the **Manual Backup** page of the ICPAM Server Administration utility



**Note**

Manual backups are enabled only when automatic backups are disabled. See the [“Disabling Automatic Backups”](#) section on page A-6.

*Figure A-3 Manual Backup page of the ICPAM Server Administration Utility*

The three most recent backup files are listed at the top of the page. When a fourth backup file is added, the oldest file is deleted. You can right-click a filename to save it to a local or network drive, or use the option in the following procedure to automatically copy the backup files to a remote server.

The file name includes the date and the server software version number. For example:

- **bak-04122016-0933561.5.3\_0.3.6.cpam.noevents.zip** is the name of a no-events backup file created 4/12/2016 on a CPAM 1.5.3 system
- **bak-05242016-1452592.2.0\_0.3.8.ICPAM220.zip** is the name of a full backup file created 5/24/2016 on an ICPAM 2.2.0 system

**Procedure**

To perform a one-time manual backup, do the following:

- 
- Step 1** Log on to the ICPAM appliance, as described in [Logging on to the ICPAM Server Administration Utility, page 2-2](#).
- Step 2** Select **Setup** and then **Backup**.
- Step 3** Select the **Manual** tab, as shown in [Figure A-3](#).



---

**Note** Manual backups are enabled only when automatic backups are disabled. For details, see the [“Disabling Automatic Backups” section on page A-6](#).

---

- Step 4** Type and re-type a password for the backup file.  
If you need to use this backup file later to restore the data, this password must be entered at that time.
- Step 5** (Optional) To exclude the events (and back up only the configuration data), select the **Exclude Events** check box.
- Events will not be backed up and cannot be restored.
  - To remove historical events from the main database and reduce the size of the backup file, review the [“Archiving the Historical Events Database” section on page A-9](#).
  - For instructions about how to prune old events from the main database, or how to remove them from the database by creating an archive of historical events, see the [“Archiving Historical Events” section on page 2-25](#).
- Step 6** (Optional) Automatically copy the backup to a remote server.  
Use this option to automatically copy the backup file to a remote FTP or SFTP server.
- a. Check the **Copy to remote server** check box.  
The **remote server** settings appear, as shown in [Figure A-3](#).
  - b. Select the server protocol:
    - **FTP**: for standard File Transfer Protocol servers.
    - **SFTP**: for secure file transfers using the Secure File Transfer Protocol (also known as the SSH File Transfer Protocol).
  - c. Type the **IP Address** of the FTP or SFTP server.
  - d. Type the **Username** for the FTP or SFTP server account.
  - e. Type the **Password** for the FTP or SFTP server account.
  - f. Type the directory **Path** on the FTP or SFTP server where the backup should be saved. The path must exist on the remote server. If the directory is not available, the backup will fail.



---

**Note** If the IP address, username, password, or path is incorrect, or if the server is not available, then the backup is not copied to the remote server. The backup is still created on the ICPAM server.

---

- Step 7** Click **Backup Now** to begin the backup process and create a new .zip backup file.
- When the backup is complete, the new backup file is added to the top of the screen, as shown in [Figure A-3](#).
    - The file name includes the date and the server software version number. For example:
      - **bak-04122016-0933561.5.3\_0.3.6.cpam.noevents.zip** is the name of a no-events backup file created 4/12/2016 on a CPAM 1.5.3 system
      - **bak-05242016-1452592.2.0\_0.3.8.ICPAM220.zip** is the name of a full backup file created 5/24/2016 on an ICPAM 2.2.0 system
    - Only the three most recent backup files are saved to the ICPAM server. When a fourth backup file is added, the oldest file is deleted.
    - To manually save the backup file to another location, right-click the filename and select a save option from the browser menu.
  - If the backup is copied to a remote server, a copy of the file is saved to the server location configured in [Step 6](#).
    - If the remote server settings are incorrect or the directory path does not exist, the file is not copied and an error message is displayed.
    - The backup is still saved to the ICPAM server even if the remote server is unavailable.
- 

## Archiving the Historical Events Database

When you copy and prune old events (as described in the “[Archiving Historical Events](#)” section on [page 2-25](#)), the events are moved to a separate ICPAM database. Although the events are no longer displayed in **Events and Alarms**, they can still be included in system backups (see the “[Understanding Live, Pruned, and Archived Events](#)” section on [page 2-25](#)).

Archiving these historical events removes them from the database and saves them to .zip file that can be saved to another location. The file includes a password-protected SQL script, and can be run on an offline database to view the purged events. Archiving historical events improves system performance and reduces the size of the backup file.

You can right-click a filename to save it to a local or network drive, or automatically copy the archive files to a remote FTP or SFTP server.

The historical event management settings are entered during the initial server setup. See the “[Initial Setup Instructions](#)” section on [page 2-7](#) for instructions. You can modify those initial settings later using the ICPAM Server Administration utility, as described in the “[Archiving Historical Events](#)” section on [page 2-25](#).

## Restoring a Server Backup File

Complete the procedure in this section to restore data from a backup file, or from an archive file.

Note the following when restoring data or archives:

- Data can be restored only when the server is stopped.
- To restore a backup in a high-availability (HA) configuration, stop both servers. The backup can be restored to either the active server or the standby server.

- Starting with the CPAM 1.2.0 release, data can be restored to a server with a different high-availability (HA) configuration. For example, data from a standalone server can be restored to a server in HA mode.
- Backup files include the ICPAM configuration and other data.
- Archive files include only historical events that were removed from the database using the Archive function. You can view historical events recovered from an archive file using **Reports**, but they cannot be viewed in the **Events and Alarms** module. See [Archiving the Historical Events Database, page A-9](#) for more information.
- If an archive from CPAM release 1.2.0 or earlier is restored, you will automatically be redirected to the *Events* configuration page of the ICPAM Server Administration utility. Use this page to enter the required setting to prune and archive old events. See the “[Archiving Historical Events](#)” section on [page 2-25](#) for information and instructions. You cannot start the server or perform other activities until the event archiving is successfully configured.

### Procedure

To restore the data from a backup or archive file, do the following:

---

**Step 1** Verify that you have the correct backup file from either the Active or Standby server.

See [Backing up the ICPAM Database, page A-2](#).

**Step 2** If you have a high-availability (HA) configuration, stop the Standby server.



#### Note

- For redundant HA configurations, ensure that both the Active and Standby servers are stopped (in **Down** state). Restoring a backup while either of the servers is up will result in unexpected behavior.
- If you are upgrading or reinstalling the server software, the Standby server should already be in the Down state.

- 
- a. Log on to the Standby ICPAM appliance.
  - b. Select **Monitoring** and then select **Status**.
  - c. Click the **Stop** button on the right side of the Admin State row.
  - d. Verify that the Admin State is *Down*, as shown in [Figure A-4](#).

Figure A-4 Server Admin State (Down) for the Standby Server

The screenshot shows the 'Monitoring > Status' page of the Identiv Connected PAM Server Administration interface. The 'Server' section is highlighted with a green box, showing the following details:

|                          |              |      |
|--------------------------|--------------|------|
| Admin State:             | Down         | Stop |
| Server Mode:             | Active       |      |
| Version:                 | 2.0.0        |      |
| Serial Number:           | 000C29200881 |      |
| High Availability Audit: | disabled     |      |

The 'Services' section below shows:

|                 |         |         |
|-----------------|---------|---------|
| TFTP Service    | Up      | Stop    |
| Web Service API | Enabled | Disable |

The interface also features a 'Cisco Compatible' logo and a copyright notice at the bottom: 'Copyright © 2015 Identiv, Inc. | All Rights Reserved.'

**Step 3** Stop the Active server.



**Note**

- For redundant HA configurations, ensure that the Admin State is **Down** for both the Active server and the Standby server. Restoring a backup while either of the servers is up will result in unexpected behavior.
- If you are upgrading or reinstalling the server software, the Standby server should already be in the **Down** state.

- a. Log on to the Active ICPAM appliance.
- b. Select **Monitoring** and then select **Status**.
- c. Click the **Stop** button on the right side of the Admin State row.
- d. Verify that the Admin State is *Down*, as shown in [Figure A-4](#).

**Step 4** On the Active server, select the **Setup** tab, and then select **Restore**, as shown in [Figure A-5](#).

*Figure A-5 Restore page of the ICPAM Server Administration Utility*

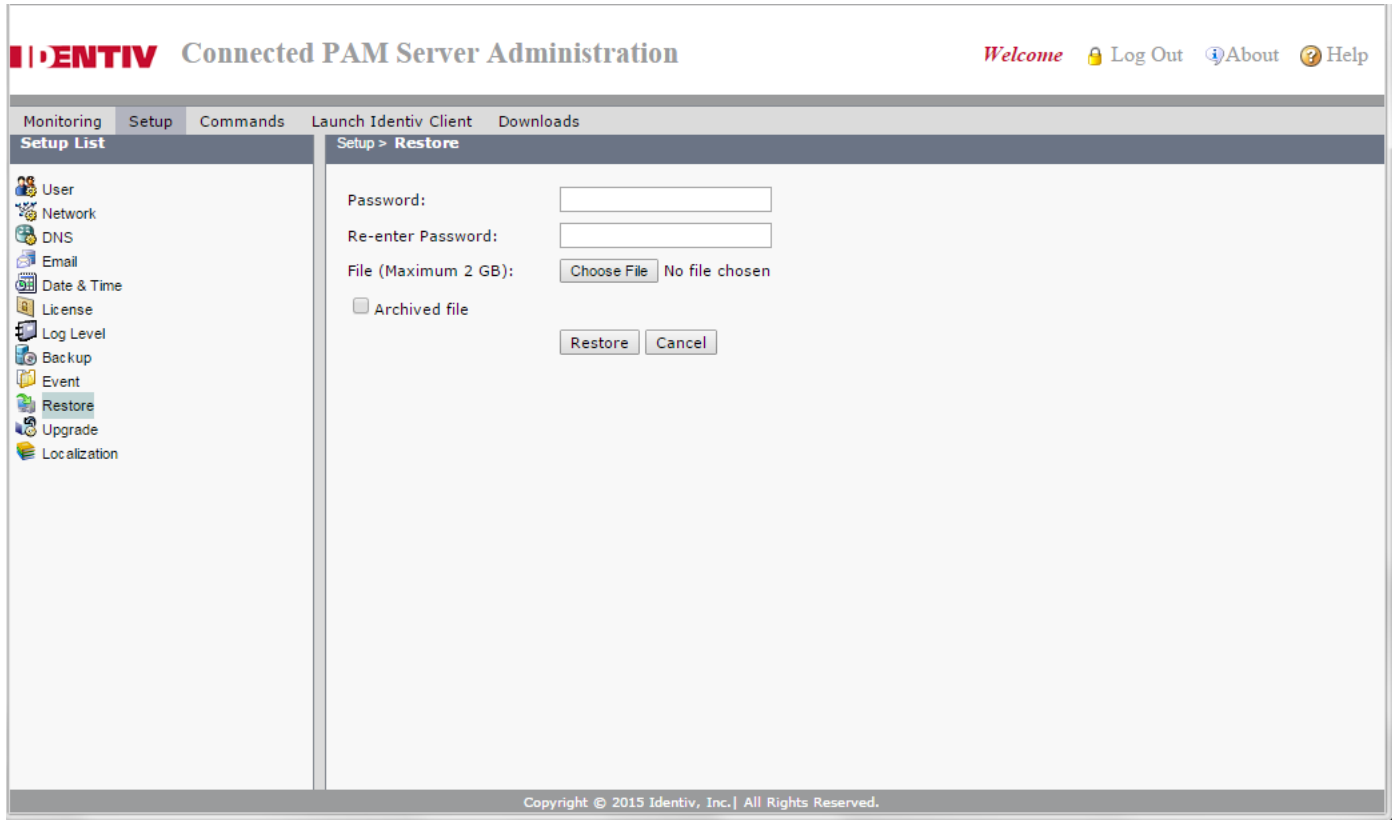

**Step 5** Type and re-type the **Password** for the backup file. This is the password that was specified when the backup file was created, as described in [Backing up the ICPAM Database, page A-2](#).

**Step 6** Click **Choose File** to locate and select the .zip backup file.

For example: bak-02102011-1141001.3.0\_0.3.25.cpm-supermicro-116

**Step 7** If the file is an archive file, select the **Archived File** check box.

See [Archiving the Historical Events Database, page A-9](#) for more information.

**Step 8** Click **Restore** and wait for the restore process to complete.

**Step 9** Wait for the server to automatically restart.

- A pop-up message appears informing you that the Web administrator utility is restarting.
- If the ICPAM Server Administration utility disconnects, a browser error message may be shown. Wait approximately five minutes for the server to restart, and then refresh your browser to log in again.

**Step 10** If restoring a backup from CPAM Release 1.2.0 or earlier to Release 1.3.0 or higher, you must enter the event pruning and archive settings, as shown in [Figure A-6](#) and [Figure A-7](#).



**Note** If you are upgrading from CPAM release 1.3.0 or higher, skip to [Step 11](#).

- Pruned events are removed from the main database table and placed in a separate database, allowing you to reduce the size of the main database date while keeping them accessible on the ICPAM system. Pruned events are not visible in **Events & Alarms**, but are included in **Reports**. Pruned events are also included in system backups.
- Archived events are removed from all ICPAM database tables and copied to a compressed file. The file includes a password-protected SQL script, and can be run on an offline database to view the purged events. Archived events are not visible in the **Events & Alarms** listings or **Reports**, and are not included in system backups.

**Note**

These settings are only required if restoring a backup from CPAM Release 1.2.0 or earlier. After the restore is complete, you can make additional changes. See the “[Archiving Historical Events](#)” section on [page 2-25](#) for more information.

*Figure A-6 Initial Setup: Event Pruning and Archiving*

The screenshot shows the 'Identiv Connected PAM Server Administration' web interface. The top navigation bar includes 'Monitoring', 'Setup', 'Commands', 'Launch Identiv Client', and 'Downloads'. The 'Setup' menu is expanded to show 'Event Management'. The 'Pruning' tab is active, and the 'Live Event Window(days)' is set to 30. The 'Schedule' is set to 'Weekday: Wednesday' at '14:00:00' with 'Pruning Hours' set to '1.0'. The 'Update' and 'Cancel' buttons are visible at the bottom of the form.

- Select the **Pruning** tab (shown in [Figure A-6](#)), and enter the following settings:
  - **Live Event Window (days)**—Enter a value between 0 and 500 (inclusive). This is the number of days of events that will be available on live view. All the events older than the specified days will be removed at the pruning schedule time. For example, enter 30 to keep events in the live view for 30 days. After midnight on day 30, the events are subject to pruning and archiving (depending on the schedule defined in the following steps).

**Note**

- To ensure that events are regularly pruned, we recommend entering 60 days or less in the **Live Events Window** field. Entering a value greater than 60 can cause an excessive number of event entries to accumulate in the main database and negatively impact system performance.
- The number is rounded to midnight of the last day.

- **Schedule**—define the time and frequency when events should be pruned.
  - **Date**—To schedule pruning for one day per month, select **Date** and then select a day of the month. For example: 15.
  - **Weekday**—To schedule pruning once per week, select **Weekday** and then select a day of the week. For example: Tuesday.
  - **Daily**—To run pruning every day, select **Daily**.
  - **Time**—Type the time in 24 hour format (hh:mm:ss). For example, to run pruning at 2 p.m., enter 14:00:00. To run pruning at 1 a.m., enter 01:00:00.
  - **Pruning Hours**—Select the maximum amount of time for the pruning operation.

*Figure A-7 Archiving Events*

The screenshot shows the 'Identiv Connected PAM Server Administration' web interface. The main navigation bar includes 'Monitoring', 'Setup', 'Commands', 'Launch Identiv Client', and 'Downloads'. The 'Setup' menu is expanded to show 'Event Management'. The 'Event Management' page has two tabs: 'Pruning' and 'Archive'. The 'Archive' tab is active. The form contains the following fields and options:

- Password:** [Redacted]
- Re-enter Password:** [Redacted]
- Historic Event Window(days):** 60
- Automatic archive**
- Recurrence:**
  - Date:** 5
  - Weekday:** [Dropdown]
  - Daily:**
- Time:** 13:00:00 (hh:mm:ss)
- Copy to remote server**

Buttons: Update, Cancel

- Select the **Archive** tab (Figure A-7) and enter the following settings:



**Tip**

The archive settings are required during the initial setup. After a successful restore, you can disable auto-archiving if necessary. See the [“Archiving Historical Events” section on page 2-25](#).

- Type and re-type the administrator **Password**. This password is used to restore the archive file (similar to backup files).
- **Historic Event Window (days)**—Enter the number of days that events will be available for reports. After the minimum number of days the events will be archived to a compressed file. For example, enter 30 to keep events in the live view for 30 days. After midnight on day 30, the events are subject to archiving (depending on the schedule defined in the following steps).
- **Automatic archive**—Select this check box to enable automatic archiving on the specified schedule.
- Enter a **Schedule** when the historic events will be removed from the pruned database and placed into a compressed archive file (archived files are listed above the entry fields).
  - **Date**—To schedule archiving for one day per month, select **Date** and then select a day of the month. For example: 15.
  - **Weekday**—To schedule archiving once per week, select **Weekday** and then select a day of the week. For example: Tuesday.
  - **Daily**—To run archiving every day, select **Daily**.
  - **Time**—Enter the time in 24 hour format (hh:mm:ss). For example, to run archiving at 2 p.m., enter 14:00:00. To run archiving at 1 a.m., enter 01:00:00.
- (Optional) Select **Copy to remote server** to automatically copy the archived event files to a remote FTP or SFTP location.

**Note**

Only the three most recent archive files are saved. If you do not save the archive file manually or by copying it to a remote server, then the oldest file will be permanently deleted when the fourth file is created.

- **FTP**: for standard File Transfer Protocol servers.
- **SFTP**: for secure file transfers using the Secure File Transfer Protocol (also known as the SSH File Transfer Protocol).
- **Address**—the IP address or hostname of the remote server.
- **Username**—the username required to log in to the server.
- **Password**—the login password for the remote server.
- **Path**—the directory path where the compressed archive will be copied. The path must exist on the remote server. If the directory is not available, the archive will fail.

- c. Click **Update** to apply the changes.

**Step 11** Verify that the Active server is up.

- a. Log on to the Active ICPAM appliance.
- b. Select the **Monitoring** tab and then select **Status**.
- c. Verify the following, as shown in [Figure A-8](#):
  - The Admin State is **Up**.
  - The Server Mode is **Active**.

Figure A-8 Server Admin State (Up) for the Active Server

The screenshot shows the 'Status' page of the Identiv Connected PAM Server Administration interface. The page is titled 'Monitoring > Status'. Under the 'Server' section, the 'Admin State' is 'Up' and the 'Server Mode' is 'Active'. A green box highlights these two items. Other server details include Version: 2.0.0, Serial Number: 000C29200881, and High Availability Audit: disabled. There is a 'Stop' button next to the Admin State. Under the 'Services' section, 'TFTP Service' is 'Up' and 'Web Service API' is 'Enabled'. There are 'Stop' and 'Disable' buttons next to these services. A 'Cisco Compatible' logo is visible in the bottom right corner. The footer contains the copyright notice: 'Copyright © 2015 Identiv, Inc. | All Rights Reserved.'

- Step 12** If the Status is *Down*, click **Start** to manually restart the server and then verify that the Admin State is *Up*.
- Step 13** In a high-availability (HA) configuration, restart the Standby server.
- Log on to the Standby ICPAM appliance.
  - Select the **Commands** tab, and then select **Start Server**.
  - Select the **Monitoring** tab and then select **Status**.
  - Verify the following:
    - The Admin State is **Up**.
    - The Server Mode is **Standby**.

## Upgrading the Server Software

---

This appendix describes how to upgrade or reinstall the ICPAM server software, desktop client software, and controller firmware.

### Contents

- [Upgrade Notes for Release 2.1, page B-2](#)
- [Obtaining Software Images, page B-8](#)
- [Obtaining Release Notes and Other Related Documentation, page B-10](#)
- [Upgrading the ICPAM Desktop Software, page B-10](#)
- [Upgrading the ICPAM Server Software, page B-11](#)
- [Replacing an Appliance, page B-20](#)
  - [Replacing a Stand-Alone \(Non-Redundant\) Appliance, page B-20](#)
  - [Replacing Both Appliances in an HA Configuration, page B-21](#)
- [Reinstalling the ICPAM Server Software from a Recovery CD, page B-24](#)

# Upgrade Notes for Release 2.1

The upgrade topics and their associated notes are discussed in the following subsections.

- [Event Archive Settings Are Required, page B-3](#)
- [Localization Feature Requires Database Upgrade, page B-4](#)
- [Controller Firmware Must Be the Same Version as ICPAM, page B-4](#)
- [Credential Download Frequency Must be 60 Minutes or Higher, page B-5](#)
- [Door Groups Feature Added to Device Groups, page B-5](#)
- [Enabling the Password Recovery Feature, page B-5](#)
- [Upgrading From CPAM Release 1.3.0 to ICPAM Release 2.1, page B-5](#)
- [Split Holiday Schedule Configurations By Month, page B-6](#)
- [Select the Following Options When Upgrading Gateway Firmware, page B-6](#)
- [Generic Output Devices Installed Prior to Release 1.1.0 Must Be Rewired, page B-6](#)
- [Generic Output Device Command and Event Name Changes, page B-7](#)
- [Browser Time-out, page B-7](#)
- [Upgrade the ICPAM Desktop Client Software, page B-7](#)
- [Java Requirements, page B-7](#)
- [Stop EDI Projects Before Upgrading ICPAM, page B-7](#)
- [Change the Database Password Message, page B-8](#)

## Event Archive Settings Are Required

If upgrading from CPAM Release 1.3 or earlier, you are automatically redirected to the **Events** configuration page of the ICPAM Server Administration utility (Figure B-1).

Figure B-1 Initial Setup: Event Pruning and Archiving

Use this page to enter the required event pruning and archive settings. You cannot start the server or perform other activities until event archiving is successfully configured.

The following additional conditions apply:

- If you are upgrading redundant HA servers, the historical event archive settings are only required on the primary appliance.
- If the appliance being upgraded has existing automation rules configured for historical events, the following occurs during the upgrade:
  - Commands to copy, prune, or archive events are removed. If the automation rule only includes these commands, then the entire rule is removed. The system will use the new event pruning and archiving settings you are prompted to enter during the upgrade.
  - If the automation rule also includes actions to create reports, then the automation rule is upgraded and the reports rules are saved in the upgraded system.

For instructions and more information, see the [“Archiving Historical Events”](#) section on page 2-25.

## Localization Feature Requires Database Upgrade

If you upgrade the ICPAM appliance from CPAM release 1.4.1 or lower to release 1.5.0 or higher, you must also upgrade the system database to support localization. This is a one-time process performed by clicking an **Enable Localization** button the first time you access the localization feature (Figure B-2).

Figure B-2 Enabling Localization

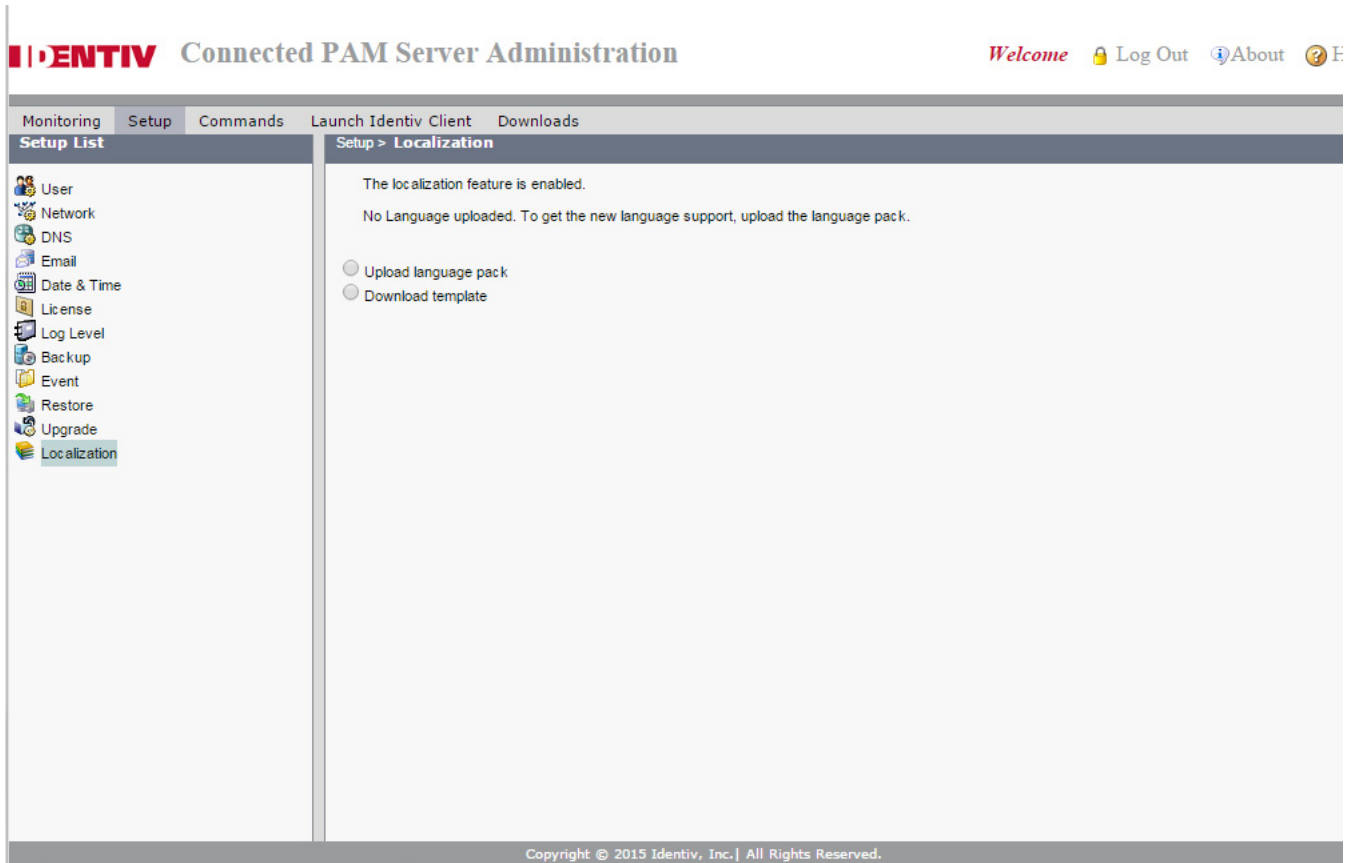

### Note

- This procedure is also required if you restore a data backup from CPAM Release 1.2.0 or lower to Release 1.3.0 or higher.
- This process can take up to one hour (or more) to complete for large databases.
- For more information, see the [“Installing and Revising Language Packs”](#) section on page 2-30.

## Controller Firmware Must Be the Same Version as ICPAM

Controllers must have the same firmware version as the ICPAM appliance server software. This includes the major version, minor version, maintenance version, and the build number. If any difference in versions exists between the controller and the appliance, then only a restricted set of operations (such as image upgrade) can be performed.

## Credential Download Frequency Must be 60 Minutes or Higher

The Credential download frequency cannot be set lower than 60 minutes. If a number less than 60 is entered, the setting will be reset to 60.



Note

The Credential download frequency defines how often (in minutes) credential information is downloaded to the controllers.

To access the **Credential download frequency** setting, see [Advanced page of the System Configuration window, page 17-37](#).

## Door Groups Feature Added to Device Groups

In CPAM release 1.2.0 and higher, the Door Groups module is included in the Device Groups module.

Any Door Group configurations from previous releases are automatically included in the Device Groups module following an upgrade.

Select **Device Groups** from the **Doors** menu to access the module.

## Enabling the Password Recovery Feature

To enable the ICPAM Server Administration utility password recovery feature, the following fields must be configured (if not already set):

- **Email Address**
- **SMTP Server Address**
- **SMTP Email Address from**

See [Enabling the Password Recovery Feature, page B-5](#) for instructions.

## Upgrading From CPAM Release 1.3.0 to ICPAM Release 2.1

To upgrade to ICPAM release 2.1 from CPAM release 1.3.0, you must first upgrade to CPAM release 1.5.0.

Post Upgrade:

- The doors without any location will be moved to the gateway or expansion module location during the upgrade.
- Doors with a different location than that of its parent GW/expansion module location will now remain in the same location. After upgrade, while editing these doors the user cannot save if the door's location is different from gateway expansion module location, hence the user has to ensure that both the door and gateway are in the same location.
- Expansion modules that are created under the GW will be assigned to the GW location independent of whether the module is assigned to any location before upgrade.

Fresh Installation:

- The Modules will be assigned to the gateway location by default and the location value will be read-only for both default and expansion modules.

- Newly created doors will be assigned to the gateway location by default, independent of whether it is created either using default module or expansion module or both.

## Split Holiday Schedule Configurations By Month

Holiday schedules that span two months (for example, December 25 through January 4) do not operate correctly. CPAM Release 1.2.0 prevents this configuration, and you must split the Holiday into two entries: one that covers the first month and the second that covers the following month.

For example, if a holiday schedule is required for December 25 through January 4, create one entry for December 25 through December 31, and a second entry for January 1 through January 4.

## Select the Following Options When Upgrading Gateway Firmware

When upgrading gateway firmware images to ICPAM release 2.1 from any earlier release, select the following options:

- **Set as active image:** (checked by default) make the firmware file new active image.
- **Delete configuration:** delete the module configuration. The configuration is automatically reloaded when the module established communication with the ICPAM appliance.
- **Delete events:** delete all events stored on the module.
- **Reset Gateway:** (checked by default) perform a soft reset to powercycle the module. Changes to the active image are applied only after the gateway is reset.



### Note

---

When all options are selected, wait approximately 10-15 minutes for the firmware upgrade to complete.

---

See the [Upgrading Gateway Firmware Images Using ICPAM, page C-11](#) for instructions, or refer to the *Cisco Physical Access Gateway User Guide*.

## Generic Output Devices Installed Prior to Release 1.1.0 Must Be Rewired

All generic output devices installed in CPAM systems prior to release 1.1.0 were connected to the gateway, reader, or output modules with the wiring reversed. Starting with CPAM release 1.1.0, the wires for these output devices must be reinstalled to match the device manufacturer's recommended connections.

### Required Generic Output Device Connections in CPAM Release 1.1.0

Disconnect all Generic Output devices installed with Cisco PAM release 1.0.0, 1.0.1, or 1.0.3, and do the following:

- Connect *Normally Open* devices to the **N.O.** and **C** connectors on the gateway, reader, or output module.
- Connect *Normally Closed* devices to the **N.C.** and **C** connectors on the gateway, reader, or output module.

Failure to re-wire these devices will cause the devices to act in the opposite way intended.

See the *Cisco Physical Access Gateway User Guide* for more information on module and device wiring.



## Generic Output Device Command and Event Name Changes

The following generic output device command names were changed for CPAM Release 1.1.0 and higher. The functionality is the same:

| Release 1.0.0 Command Name | Release 1.1.0 and Higher Command Name |
|----------------------------|---------------------------------------|
| Turn output off            | Activate Relay                        |
| Turn output on             | Deactivate Relay                      |

The following generic output device event names were changed for CPAM Release 1.1.0. The functionality is the same:

| Release 1.0.0 Event Name | Release 1.1.0 and Higher Event Name |
|--------------------------|-------------------------------------|
| Output Off               | Output Deactivated                  |
| Output On                | Output Activated                    |

## Browser Time-out

When upgrading, the web browser may display an error such as “Page Not Found” while the upgrade is in process. Wait approximately five minutes for the upgrade to complete, then refresh the browser to display the login page.

## Upgrade the ICPAM Desktop Client Software

Always upgrade the ICPAM desktop client when the server software is upgraded. If the versions are not the same, an error will occur when launching the desktop client. See [Installing or Updating the ICPAM Desktop Software, page 3-2](#).

## Java Requirements

Before installing the ICPAM client, ensure that your PC has Oracle Java Runtime Environment (JRE) 1.7 32-bit installed.

- To install Java 1.7, log on to the server administration console, select **Downloads**, and then select **JRE 1.7 (Windows)**.
- To download the latest Java, go to <http://www.oracle.com/technetwork/java/javase/downloads/jre7-downloads-1880261.html>.

## Stop EDI Projects Before Upgrading ICPAM

Stop any running EDI projects before upgrading the ICPAM appliance software. After the upgrade, re-import the project to EDI Administration and start it again. See [Importing, Starting, and Monitoring EDI Projects in ICPAM, page 14-40](#) for instructions to stop, start, and import EDI projects.

If EDI projects are not stopped before an ICPAM upgrade, the project execution (or run) will not be successful. If this occurs, contact your Identiv support representative for assistance.

## Change the Database Password Message

After an upgrade, if the server is started using the **Start** command in the Commands menu of the ICPAM Server Administration utility, a message appears asking if you want to change the database password. Click **Cancel**. This password is a security measure used for troubleshooting and technical support. It does not impact user operation.

## Obtaining Software Images

To access the self-service portal and obtain software, documents, and tools, do the following:

**Step 1** Go to the following URL: <http://www.identiv.com>



**Tip**

You can also log in to the Identiv Support Center at <http://www.identiv.com/support-icpam>.

**Step 2** Click the **Download Software** link (Figure B-3).

*Figure B-3 Download ICPAM Software Updates*

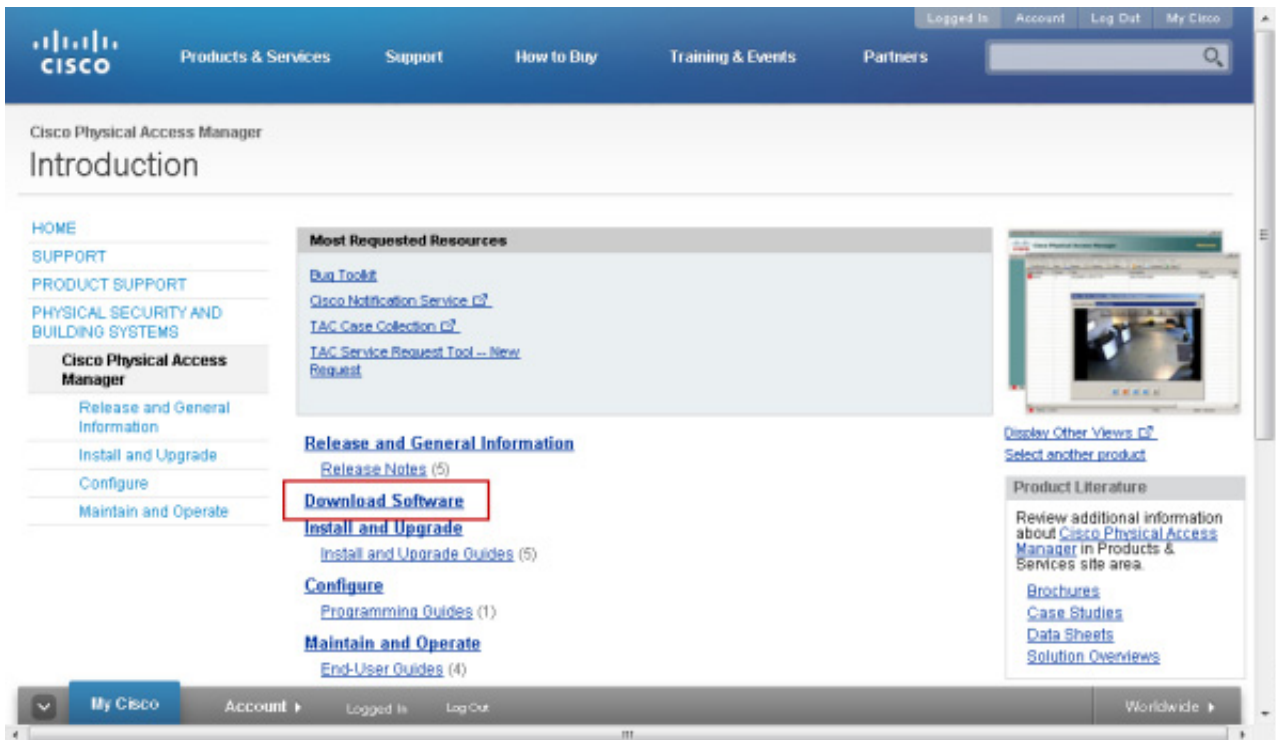

**Step 3** Click the link for the correct release, or use the search function to locate the software release (Figure B-4).

Figure B-4 Select and Download a Software Release

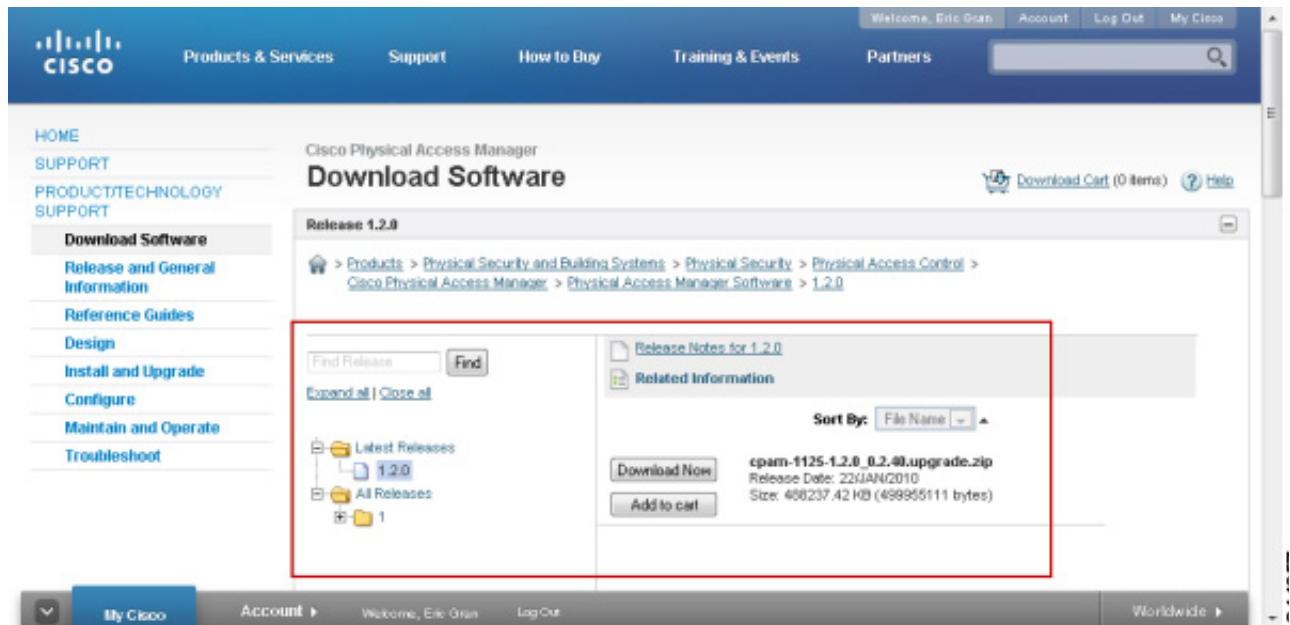

- Step 4** Click **Download Now**.
- Step 5** Follow the on-screen instructions to save the download file to a local or network drive:
- Verify the download details.
  - Click **Proceed With Download**.
  - Accept the *End User License Agreement*.
  - Select a download option (Java or non-Java).
  - Select a location to save the file.
  - Wait for the download to complete.
- Step 6** Locate and extract the compressed .zip file on your drive.  
For example: cpam-2.1\_0.1.10.upgrade.zip.
- Step 7** Open the directory and verify that the file is correct.  
The filename includes the release number and other details. For example: cpam-2.1\_0.1.10.upgrade.bin.

# Obtaining Release Notes and Other Related Documentation

To obtain the latest documentation, including release notes, do the following:

---

**Step 1** Go to one of the following URLs:

- ICPAM Release Notes  
[http://www.identiv.com/en/US/products/ps9688/prod\\_release\\_notes\\_list.html](http://www.identiv.com/en/US/products/ps9688/prod_release_notes_list.html)
- ICPAM Documentation  
[http://www.identiv.com/en/US/products/ps9688/tsd\\_products\\_support\\_series\\_home.html](http://www.identiv.com/en/US/products/ps9688/tsd_products_support_series_home.html)
- Cisco Physical Access Gateway Documentation  
[http://www.cisco.com/en/US/products/ps9687/tsd\\_products\\_support\\_series\\_home.html](http://www.cisco.com/en/US/products/ps9687/tsd_products_support_series_home.html)

**Step 2** Click the link for the appropriate guide.

For example: **Install and Upgrade Guides** or **End-User Guides**.

**Step 3** Use these publications to learn how to install, upgrade, and use the Identiv Connected Physical Access Manager hardware and software.



**Tip**

---

Release Notes are also included with software downloads, or you can access the release notes while downloading software updates. See the [“Obtaining Software Images”](#) section on page B-8.

---

## Upgrading the ICPAM Desktop Software

Always upgrade the ICPAM desktop client whenever the server software is upgraded. If the versions are not the same, an error will occur when launching the desktop client. See [Installing or Updating the ICPAM Desktop Software](#), page 3-2 for instructions.

# Upgrading the ICPAM Server Software

To upgrade the ICPAM server software, you must first stop the server. If you are upgrading redundant high availability (HA) servers, you must stop both servers, upgrade the server that was originally designated as the Active server, and then upgrade the Standby server.

## Before You Begin

- The following conditions apply when upgrading the ICPAM server software:
  - Upgrading either a single appliance or redundant servers causes system downtime. All servers must be placed in *Down* state to perform the upgrade.
  - System downtime can result in a temporary loss of data. Log and other system messages sent from the Cisco Physical Access Gateways and other hardware devices may be dropped during the upgrade process. Identiv recommends performing a manual upgrade only when system usage is low.
  - If upgrading two redundant appliances (HA configuration), complete the upgrade on one appliance before beginning the upgrade on the second appliance. If the second appliance is upgraded before the first appliance upgrade is complete, unrecoverable conditions may occur, forcing a restore from a backup file.
  - Software downgrades are not supported.
- Review all [Upgrade Notes for Release 2.1, page B-2](#)
- Obtain the correct software image. See [Obtaining Software Images, page B-8](#).



### Tip

The ICPAM server software is different from the desktop client software. The server software runs the appliance and provides a web administration interface used to configure and manage the server. The desktop (client) software runs on a PC and is used to configure devices and access control settings.

## Procedure

To upgrade the ICPAM server software, do the following:

- Step 1** Review the notes in [Before You Begin](#) and [Upgrade Notes for Release 2.1, page B-2](#)
- Step 2** Backup either the Active or Standby server, as described in [Backing up the ICPAM Database, page A-2](#). This backup is not required, but ensures the latest system data is preserved in case an error occurs.
- Step 3** Save the backup file to a local drive.
- Step 4** Stop the Standby server, if configured:
  - a. Log on to the Standby appliance, as described in [Logging on to the ICPAM Server Administration Utility, page 2-2](#).
  - b. Click the **Monitoring** tab and verify the Server Mode is *Standby* ([Figure B-5](#)).
  - c. Select the **Stop** button in the Admin entry.
  - d. Verify that the Admin State is *Down*.

Figure B-5 Monitoring Window in the ICPAM Server Administration Utility



IDENTIV Connected PAM Server Administration

Welcome Log Out About Help

Monitoring Setup Commands Launch Identiv Client Downloads

Monitoring > Status

Server

|                          |              |      |
|--------------------------|--------------|------|
| Admin State:             | Down         | Stop |
| Server Mode:             | Active       |      |
| Version:                 | 2.0.0        |      |
| Serial Number:           | 000C29200881 |      |
| High Availability Audit: | disabled     |      |

Services

|                 |         |         |
|-----------------|---------|---------|
| TFTP Service    | Up      | Stop    |
| Web Service API | Enabled | Disable |

Cisco Compatible

Copyright © 2015 Identiv, Inc. | All Rights Reserved.

- Step 5** Stop the Active server.
- Log on to the Active appliance.
  - Click the **Monitoring** tab and verify the Server Mode is *Active* (highlighted in Figure B-5).
  - Click the **Stop** button to the right of the Admin State entry,
  - Verify that the Admin State is *Down*.
- Step 6** On the Active server, select the **Setup** tab, and then select **Upgrade** in the left pane, as shown in Figure B-6.

Figure B-6 Upgrade Window in the ICPAM Server Administration Utility

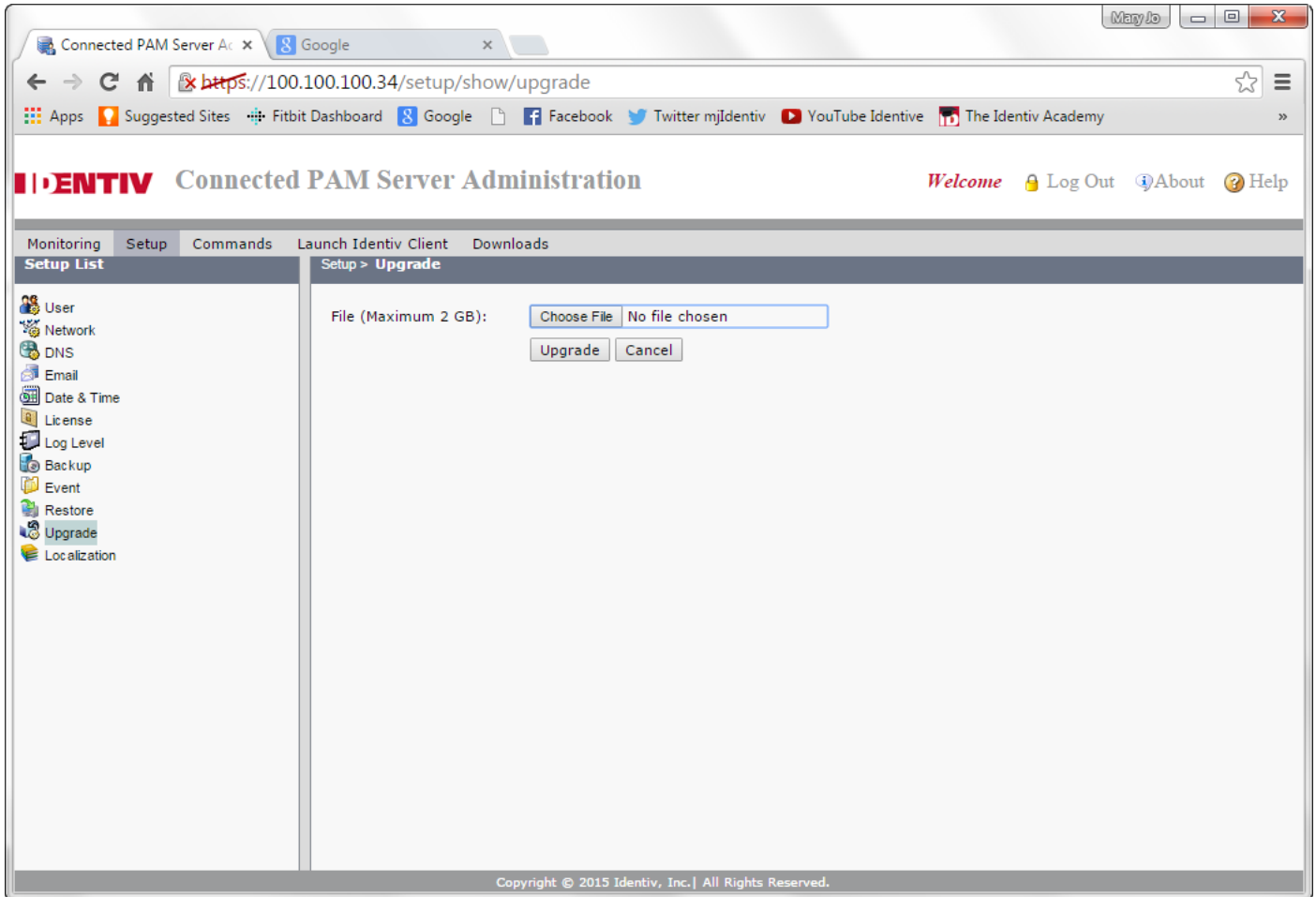

- Step 7** Click **Choose File** to locate and select the upgrade image.  
See the “[Obtaining Software Images](#)” section on page B-8 to download the upgrade software, if necessary.  
For example: cpam-2.1\_0.1.10.upgrade.bin
- Step 8** Click the **Upgrade** button.
- A message appears informing you that the upgrade is starting and the Web page will refresh.
  - If the ICPAM Server Administration utility disconnects, a browser error message may be shown. Wait approximately five minutes for the server to restart, and then refresh your browser.
- Step 9** The log in page appears when the upgrade is complete.
- Step 10** Enter your existing username and password to log into the appliance.
- Step 11** If upgrading from CPAM Release 1.2.0 or earlier to Release 1.3.0 or higher, you must enter the event pruning and archive settings, as shown in [Figure B-7](#).



**Note** If you are upgrading from CPAM release 1.3.0 or higher, skip to [Step 12](#).

- Pruned events are removed from the main database table and placed in a separate events database, allowing you to reduce the size of the main database while keeping them accessible on the ICPAM system. Pruned events are not visible in **Events & Alarms**, but are included in **Reports**. Pruned events are also included in system backups.
- Archived events are removed from all ICPAM database tables and copied to a compressed file. The file includes a password-protected SQL script, which can be run on an offline database to view the purged events. Archived events are not visible in the **Events & Alarms** listings or in **Reports**, and are not included in system backups.

**Tip**

These settings are only required if upgrading from CPAM Release 1.2.0 or earlier. After the upgrade is complete, you can make additional changes. See the [“Archiving Historical Events” section on page 2-25](#) for more information.

**Figure B-7** Initial Setup: Event Pruning and Archiving

- Select the **Pruning** tab (shown in [Figure B-7](#)), and enter the following settings:
  - **Live Events Window (days)**—Enter a value between 0 and 500 (inclusive). This is the number of days of events that will be available on live view. All the events older than the specified days will be removed at the pruning schedule time. For example, enter 30 to keep events in the live view for 30 days. After midnight on day 30, the events are subject to pruning and archiving (depending on the schedule defined in the following steps).

**Note**

- To ensure that events are regularly pruned, we recommend entering 30 days or less in the **Live Events Window** field. Entering a value greater than 30 can cause an excessive number of event entries to accumulate in the main database and negatively impact system performance.



- The number is rounded to midnight of the last day.
- 
- **Schedule**—define the time and frequency when events should be pruned.
    - **Date**—To schedule pruning for one day per month, select **Date** and then select a day of the month. For example: 15.
    - **Weekday**—To schedule pruning once per week, select **Weekday** and then select a day of the week. For example: `Tuesday`.
    - **Daily**—To run pruning every day, select **Daily**.
    - **Time**—Enter the time in 24 hour format (hh:mm:ss). For example, to run pruning at 2 p.m., enter `14:00:00`. To run pruning at 1 a.m., enter `01:00:00`.
  - **Pruning Hours**—This field is enabled only if **Daily** is selected in **Schedule**. The default value is 1.

Figure B-8 Archiving Events

The screenshot shows the 'Initial Setup' page for ICPAM Server Administration. The 'Pruning' section is active, and the 'Archive' tab is selected. The form contains the following fields and options:

- Number of Historic Events: 1232
- Password: [Redacted]
- Re-enter Password: [Redacted]
- Historic Event Window(days): 60
- Automatic archive
- Recurrence:
  - Date: 1
  - Weekday: [Dropdown]
  - Daily:
- Time: 01:01:00 (hh:mm:ss)
- Copy to remote server
- Protocol:
  - FTP
  - SFTP
- Address: [Text Field]
- Username: [Text Field]
- Password: [Text Field]
- Path: [Text Field]

- b. Select the **Archive** tab (shown in Figure B-8) and enter the following settings:

**Tip**

The archive settings are required during the initial setup. After a successful restore, you can disable auto-archiving if necessary. See the “[Archiving Historical Events](#)” section on page 2-25.

- Enter and re-enter the administrator **Password**. This password is used to restore the archive file (similar to backup files).
- **Historic Events Window (days)**—Enter the number of days that events will be available for reports. After the minimum number of days the events will be archived to a compressed file. For example, enter 30 to keep events in the live view for 30 days. After midnight on day 30, the events are subject to archiving (depending on the schedule defined in the following steps).

- Enter a **Schedule** when the historic events will be removed from the pruned database and placed into a compressed archive file (archived files are listed above the entry fields).
  - **Date**—To schedule archiving for one day per month, select **Date** and then select a day of the month. For example: 15.
  - **Weekday**—To schedule archiving once per week, select **Weekday** and then select a day of the week. For example: `Tuesday`.
  - **Daily**—To run archiving every day, select **Daily**.
  - **Time**—Enter the time in 24 hour format (hh:mm:ss). For example, to run archiving at 2 p.m., enter `14:00:00`. To run archiving at 1 a.m., enter `01:00:00`.
- (Optional) Select **Copy to remote server** option to automatically copy the archived event files to a remote FTP or SFTP location.

**Note**

---

Only the three most recent archive files are saved. If you do not save the archive file manually or by copying it to a remote server, then the oldest file will be permanently deleted when the fourth file is created.

---

- **FTP**: for standard File Transfer Protocol servers.
- **SFTP**: for secure file transfers using the Secure File Transfer Protocol (also known as the SSH File Transfer Protocol).
- **Address**—the IP address or hostname of the remote server.
- **Username**—the username required to log in to the server.
- **Password**—the login password for the remote server.
- **Path**—the directory path where the compressed archive will be copied. The path must exist on the remote server. If the directory is not available, the archive will fail.

- c. Click **Next** to apply the settings and continue.

**Step 12** Verify the upgrade process is complete, and the Active server is in *Down* state:

- a. Log on to the Active ICPAM appliance.
- b. Select the **Monitoring** tab and then select **Status**.
- c. Verify the Server Version is correct. For example: `2.2.0`
- d. Verify the Admin State is *Down*.
- e. Verify the Server Mode is **N/A**.

Figure B-9 Server Admin State for the Active Server

The screenshot shows the 'Monitoring > Status' page of the Identiv Connected PAM Server Administration interface. The 'Server' section is highlighted with a green border and contains the following information:

|                          |              |      |
|--------------------------|--------------|------|
| Admin State:             | Down         | Stop |
| Server Mode:             | Active       |      |
| Version:                 | 2.0.0        |      |
| Serial Number:           | 000C29200881 |      |
| High Availability Audit: | disabled     |      |

The 'Services' section below shows:

|                 |         |         |
|-----------------|---------|---------|
| TFTP Service    | Up      | Stop    |
| Web Service API | Enabled | Disable |

At the bottom right, there is a 'Cisco Compatible' logo. The footer contains the text: 'Copyright © 2015 Identiv, Inc. | All Rights Reserved.'

**Step 13** (HA configurations only) Upgrade the Standby server, if configured.



**Note** The Active server must be in *Down* state when you upgrade the Standby server, as described in [Step 12](#). If a Standby server is not installed, skip to [Step 14](#).

- a. Log on to the Standby server.
- b. Select the **Monitoring** tab and then select **Status**.
- c. Verify that the Admin State is *Down*, as shown in [Figure B-9](#).
- d. Select the **Setup** tab, and then select **Upgrade**.
- e. Click **Choose File** to locate and select the upgrade image, as shown in [Figure B-6 on page B-13](#).
- f. Click **Upgrade**.



**Note** Although the Standby server is upgraded, it is still in *Down* state. Start the Active server before starting the Standby server, as described in the following steps. Otherwise, the Standby server will assume the Active role.

- Step 14** Restart the Active server.
- a. Log on to the Active ICPAM appliance, if necessary.
  - b. Select **Monitoring** and then **Status**.
  - c. Click the **Start** button to the right of the Admin State entry,
  - d. Wait for the Admin State to change to *Up*.

**Note** When the server restarts, a message may appear asking if you want to change the database password. Click **Cancel** or **OK**. This password is a security measure used for troubleshooting and technical support. It does not impact user operation,

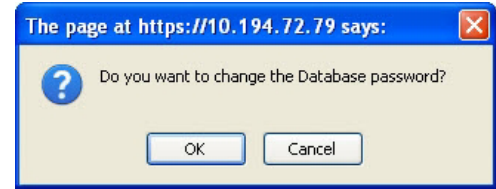

- e. Select the **Monitoring** tab and then select **Status**, as shown in Figure B-10.
- f. Verify the following:
  - Verify the Server Version is correct. For example: 2.1.0
  - Verify the Admin State is *Up*.
  - Verify the Server Mode is *Active*.

Figure B-10 Server Admin State (*Up*) for the Active Server

**Step 15** (HA configurations only) Start the Standby server.



**Note** Only start the Standby server after the Active server is *Up*, as described in Step 14.

- a. Log on to the Active ICPAM appliance.
- b. Select **Monitoring** and then **Status**.
- c. Click the **Start** button to the right of the Admin State entry.
- d. Wait for the Admin State to change to *Up*.
- e. Click **Cancel** or **OK** if a database password message appears.
- f. Verify the upgrade was successful.
  - Log on to the Standby server.
  - Select the **Monitoring** tab and then select **Status**.

- Verify the Server Version is correct. For example: 2.1.0
- Verify the Admin State is *Up*.
- Verify the Server Mode is *Standby*.

**Step 16** Restore your data backup, if necessary. See the “[Restoring a Server Backup File](#)” section on page A-9.

**Step 17** Upgrade the ICPAM desktop client, as described in [Installing or Updating the ICPAM Desktop Software](#), page 3-2. If the versions are not the same, an error will occur when launching the desktop client.

---

# Replacing an Appliance

To replace an existing appliance with a Cisco Multi Services Platform (MSP) appliance, refer to the following procedures:

- [Replacing a Stand-Alone \(Non-Redundant\) Appliance, page B-20](#)
- [Replacing Both Appliances in an HA Configuration, page B-21](#)
- [Replacing a Single Appliance in an HA Configuration, page B-22](#)

## Replacing a Stand-Alone (Non-Redundant) Appliance

When replacing a single, non-redundant server, backup the system data from the old server immediately before bringing the new server online. You can only restore the data on the new server using the most recent backup: all data and configurations added to the system since the backup will be lost.

### Procedure

- 
- Step 1** Backup the old appliance, as described in [Backing up the ICPAM Database, page A-2](#). This backup is used to restore the system data to the new appliance.
  - Step 2** Copy the backup file to a local disk, as described in [Backing up the ICPAM Database, page A-2](#).
  - Step 3** Stop the appliance.
    - a. Log on to the appliance, as described in [Logging on to the ICPAM Server Administration Utility, page 2-2](#).
    - b. Select **Monitoring** and then select **Status** (Figure B-11).
    - c. Click the **Stop** button to the right of the Admin State entry,
    - d. Verify that the Admin State is *Down*.
  - Step 4** Power off the old appliance and physically install the new appliance, as described in the *Cisco Physical Security Multi Services Platform User Guide*.
  - Step 5** Boot the new server and complete the setup instructions in [Initial Setup Instructions, page 2-7](#).
  - Step 6** Obtain and install new ICPAM licenses. See [Obtaining and Installing Optional Feature Licenses, page 2-45](#) for more information.
  - Step 7** Restore the backup file to the new server, as described in [Restoring a Server Backup File, page A-9](#).
-

## Replacing Both Appliances in an HA Configuration

To replace both appliances in a redundant HA configuration, complete the following procedure:



**Caution** This procedure results in system downtime.

### Procedure

- Step 1** Back up the Active or Standby server.
- The backup file is used to restore the system data on the new server.
- Log in to the Active or the Standby appliance.
  - Backup the system data, as described in [Backing up the ICPAM Database, page A-2](#).
  - Copy the backup file to a local disk.
- Step 2** Stop the Active appliance.
- Log on to the Active appliance, as described in [Logging on to the ICPAM Server Administration Utility, page 2-2](#).
  - Select **Monitoring** and then select **Status** (Figure B-11).
  - Verify the Server Mode is *Active*.
  - Click the **Stop** button to the right of the Admin State entry.
  - Verify that the Admin State is *Down* and the Server Mode is *N/A*, as shown in [Figure B-11](#).

*Figure B-11 Server in Admin State “Down”*

The screenshot shows the ICPAM Server Administration web interface. The top navigation bar includes 'Monitoring', 'Setup', 'Commands', 'Launch Identiv Client', and 'Downloads'. The current page is 'Monitoring > Status'. The main content area is divided into two sections: 'Server' and 'Services'. The 'Server' section has a table with the following data:

|                          |              |      |
|--------------------------|--------------|------|
| Admin State:             | Down         | Stop |
| Server Mode:             | Active       |      |
| Version:                 | 2.0.0        |      |
| Serial Number:           | 000C29200881 |      |
| High Availability Audit: | disabled     |      |

The 'Services' section has a table with the following data:

|                 |         |         |
|-----------------|---------|---------|
| TFTP Service    | Up      | Stop    |
| Web Service API | Enabled | Disable |

At the bottom right, there is a 'Cisco Compatible' logo. The footer contains the text: 'Copyright © 2015 Identiv, Inc. All Rights Reserved.'

- Step 3** Stop the Standby appliance.



---

**Note** Stopping the second appliance results in system downtime since both appliances are offline.

---

- a. Log on to the appliance, as described in [Logging on to the ICPAM Server Administration Utility, page 2-2](#).
  - a. Select **Monitoring** and then select **Status**.
  - b. Click the **Stop** button to the right of the Admin State entry.
- Step 4** Power down and physically remove the old appliances.
- Step 5** Install the new appliances, as described in the *Cisco Physical Security Multi Services Platform User Guide*.
- Step 6** Boot the new Active appliance and complete the initial configuration for an *Active* server, as described in [Initial Setup Instructions, page 2-7](#).
- Enter a *Shared IP Address*.
  - Obtain and install new ICPAM licenses, including the HA license. All optional licenses are installed on the Active server only. See [Obtaining and Installing Optional Feature Licenses, page 2-45](#) for more information.
- Step 7** Boot the new standby appliance and complete the initial configuration for a *Standby* server.
- Enter a *Shared IP Address*, as described in [Initial Setup Instructions, page 2-7](#).
  - Obtain and reinstall the HA license on the Standby server. See [Obtaining and Installing Optional Feature Licenses, page 2-45](#) for more information.
- Step 8** Verify that the redundant servers are in sync.
- a. Log in to each server.
  - b. Open the **Monitoring > Status** window.
  - c. Verify that there are entries for Peer Address, Hostname, and Sync Status.  
If the HA servers are not in sync, see the [“Monitoring” section on page 2-21](#) for a description of the HA messages that may appear.
- Step 9** Restore the backup file to the Active server, as described in [Restoring a Server Backup File, page A-9](#).
- 

## Replacing a Single Appliance in an HA Configuration

To replace a single appliance in a high-availability (HA) configuration, put the appliance in the *Admin Down* state. This transfers the Active server status to the other appliance. System data is maintained and access control functionality remains available. Next, physically replace the appliance and complete the initial configuration for a Standby server. After the server is up, system data will be synchronized from the Active HA appliance.

### Procedure

---

- Step 1** (Optional) Back up the Active or Standby server.
- The backup is not required, but we recommend performing a backup before any major operation.
- a. Log in to the Active or Standby appliance.



- b. Backup the system data, as described in [Backing up the ICPAM Database, page A-2](#).
  - c. Copy the backup file to a local disk.
- Step 2** Stop the appliance to be replaced.
- a. Log on to the appliance, as described in [Logging on to the ICPAM Server Administration Utility, page 2-2](#).
  - b. Select **Monitoring** and then select **Status**.
  - c. Click the **Stop** button to the right of the Admin State entry.
  - d. Verify that the Admin State is *Down* and the Server Mode is *N/A*, as shown in [Figure B-11](#).
- Step 3** Power down and physically remove the old appliance.
- Step 4** Install the replacement appliance, as described in the *Cisco Physical Security Multi Services Platform User Guide*.
- Step 5** Boot the new appliance and complete the initial configuration for a *Standby* server.
- Enter a *Shared IP Address*, as described in [Initial Setup Instructions, page 2-7](#).
  - Obtain and reinstall the HA license on the Standby appliance. See [Obtaining and Installing Optional Feature Licenses, page 2-45](#) for more information.
- Step 6** Wait for the initial setup process to complete.
- Step 7** Verify that the redundant servers are in sync.
- a. Log in to the appliance.
  - b. Open the **Monitoring > Status** window.
  - c. Verify that there are entries for Peer Address, Hostname, and Sync Status.  
If the HA servers are not in sync, see the “[Monitoring](#)” section on [page 2-21](#) for a description of the HA messages that may appear.
-

# Reinstalling the ICPAM Server Software from a Recovery CD

Use the recovery CD/DVD included with the ICPAM appliance to completely erase the server hard disk and re-install the ICPAM server software.

## Usage Notes

- To boot from the recovery CD/DVD, you must change the boot device order using the BIOS utility, as described in the following procedure.
- Before you begin, back up your system data. The recovery CD deletes all existing data and configurations. See the [“Backing up the ICPAM Database” section on page A-2](#).
- You can perform this procedure on a standalone appliance, or on either the active or the standby appliance in a redundant HA configuration.
- If using the recovery CD on an appliance in a HA configuration, perform the initial setup for a Standby appliance, and enter a Shared IP address.
- After the recovery process, complete the instructions in the [“Initial Setup Instructions” section on page 2-7](#) and then the [“Restoring a Server Backup File” section on page A-9](#).

## Procedure

- 
- Step 1** Backup the data on your appliance. See [Appendix A, “Backing Up and Restoring Data”](#) for more information.



### Caution

Reinstalling the server software from a CD/DVD using these instructions permanently erases all data and configurations on the ICPAM appliance. You must have at least one backup to restore the server data. See [Appendix A, “Backing Up and Restoring Data”](#) for more information.

---

- Step 2** Insert the ICPAM recovery CD into the server DVD-ROM drive.
- Step 3** Reboot the ICPAM appliance:
- Log on to the ICPAM appliance, as described in [Logging on to the ICPAM Server Administration Utility, page 2-2](#).
  - Select the **Commands** tab, and then select **Reboot**.
- Step 4** Press and hold the **Delete** key while the appliance is restarting to open the BIOS setup utility, as shown in [Figure B-12](#).

Figure B-12 BIOS Setup Utility

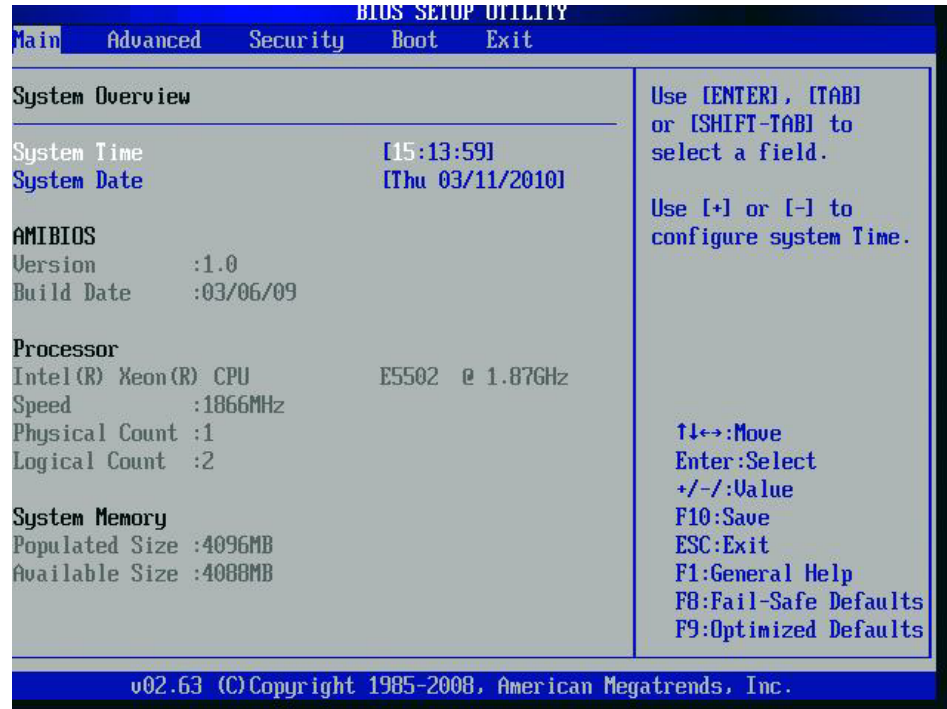

- Step 5** Change the priority order of the boot devices so the CD/DVD drive is first boot priority, and the SCSI hard drive is second priority.



**Note** If you are using the Cisco Physical Access 1125 Appliance installed with CPAM release 1.1.0 and earlier, you do not need to set the boot device using the BIOS setup utility. Skip to [Step 6](#).

- a. Use the arrow keys to select the **Boot** menu, as shown in [Figure B-13](#).

Figure B-13 BIOS Boot Settings

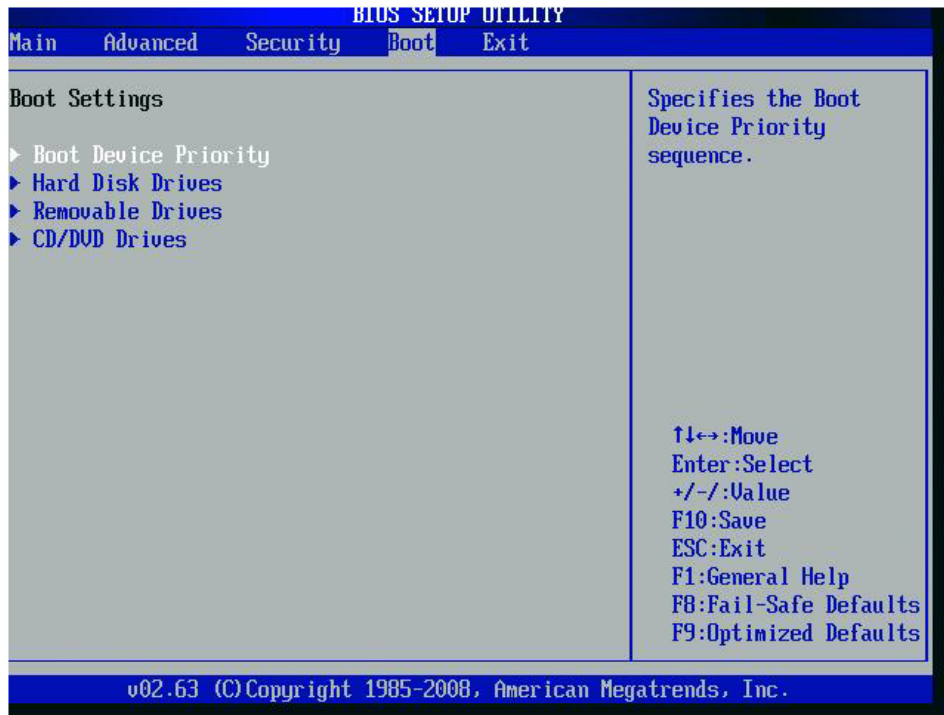

- b. Select **Boot Device Priority**.
- c. Use the arrow keys to select the **1st Boot Device**, and then press **Enter**.  
A list of available devices appears, as shown in [Figure B-14](#).

Figure B-14 Boot Device Priority Options



- d. Use the arrow keys to select the CD/DVD device, and then press the **Enter** key.
- e. Verify that the CD/DVD device is the **1st Boot Device**, and the SCSI hard drive is the **2nd Boot Device**, as shown in Figure B-15.

Figure B-15 1st Boot Device = CD/DVD

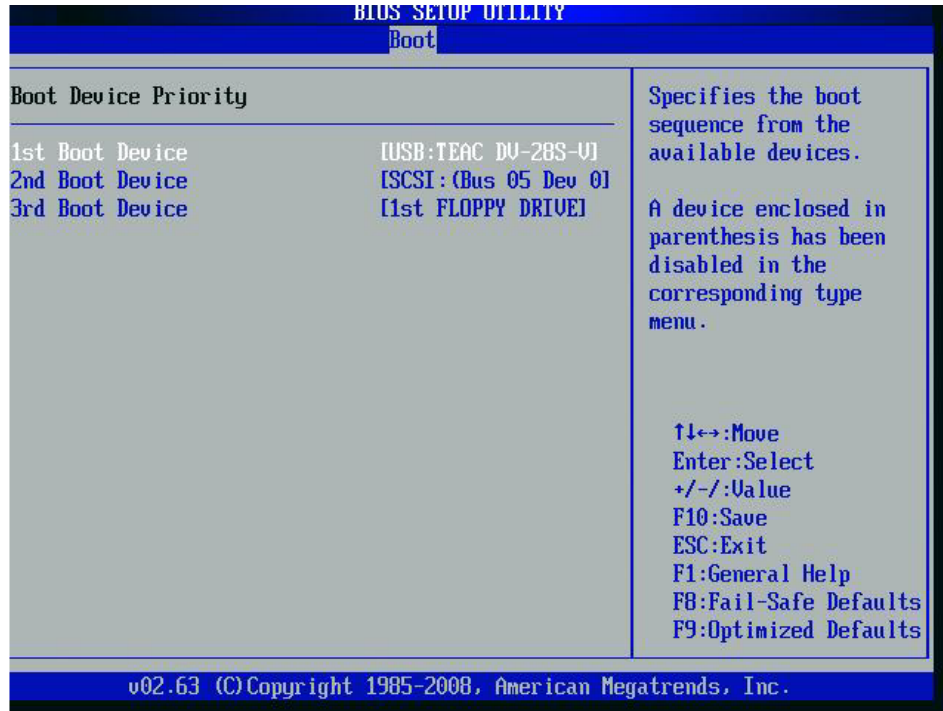

f. Press the **F10** function key to save the changes and exit the BIOS utility.

**Step 6** Wait for the CD to install the ICPAM server software.

When finished, the server will reboot again.

**Step 7** After the server reboots, remove the ICPAM recovery CD from the server DVD-ROM drive.

**Step 8** Configure the server as described in [Initial Setup Instructions, page 2-7](#).

**Step 9** Restore the system, as described in [Restoring a Server Backup File, page A-9](#).

## Upgrading and Configuring Gateways

---

Use the Hardware - Tree or Door/Location-based Hardware module to upgrade the firmware on one or more gateways, or change the network settings on the modules. You can also change the Network Time Protocol (NTP) settings on multiple gateways to ensure the time is synchronized on all devices.

**Note**

- We strongly recommend using NTP to synchronize the ICPAM appliance and gateway clocks to ensure correct event and messaging. See the [“Change the NTP Setting for Multiple Gateways” section on page C-8](#) for instructions to set NTP on gateways.
  - The gateway must be available on the network and in the Up state to use these configuration tools. For initial gateway installation and configuration, see the [ICPAM Installation Guide](#) or, for Cisco Gateway support, refer to the [Cisco Physical Access Gateway User Guide](#).
  - This appendix applies only to Cisco Gateway installations. Identiv EM-100 controller installations are dealt with in a separate section.
- 

### Contents

This appendix includes the following information:

- [Displaying the Gateway Network and Firmware Configuration, page C-2](#)
- [Changing the Gateway Network Settings, page C-3](#)
- [Changing the NTP Setting for Multiple Gateways, page C-6](#)
  - [\(Optional\) Set a Default NTP Server, page C-6](#)
  - [Change the NTP Setting for Multiple Gateways, page C-8](#)
- [Using Door/Location-based Hardware to Change Gateway Network Settings, page C-10](#)
- [Upgrading Gateway Firmware Images Using ICPAM, page C-11](#)
  - [Uploading Firmware Images to a TFTP Server, page C-11](#)
  - [Updating the Firmware on All Gateways, page C-15](#)
  - [Updating the Firmware on Individual Gateways, page C-21](#)

# Displaying the Gateway Network and Firmware Configuration

The Extended Status area of the Hardware - Tree module displays the network configuration and firmware version for a gateway.

**Step 1** Select the **Hardware - Tree** module from the **Doors** menu.

**Tip** You can also view the gateway settings from the Door/Location-based Hardware module. Filter the display to view the gateways and then select a gateway. See the “[Using Door/Location-based Hardware to Change Gateway Network Settings](#)” section on page C-10 for more information.

**Step 2** Expand the **Access GW Driver** and click on a gateway icon to select it (Figure C-1).

**Figure C-1** Gateway Software Version and IP Address Settings

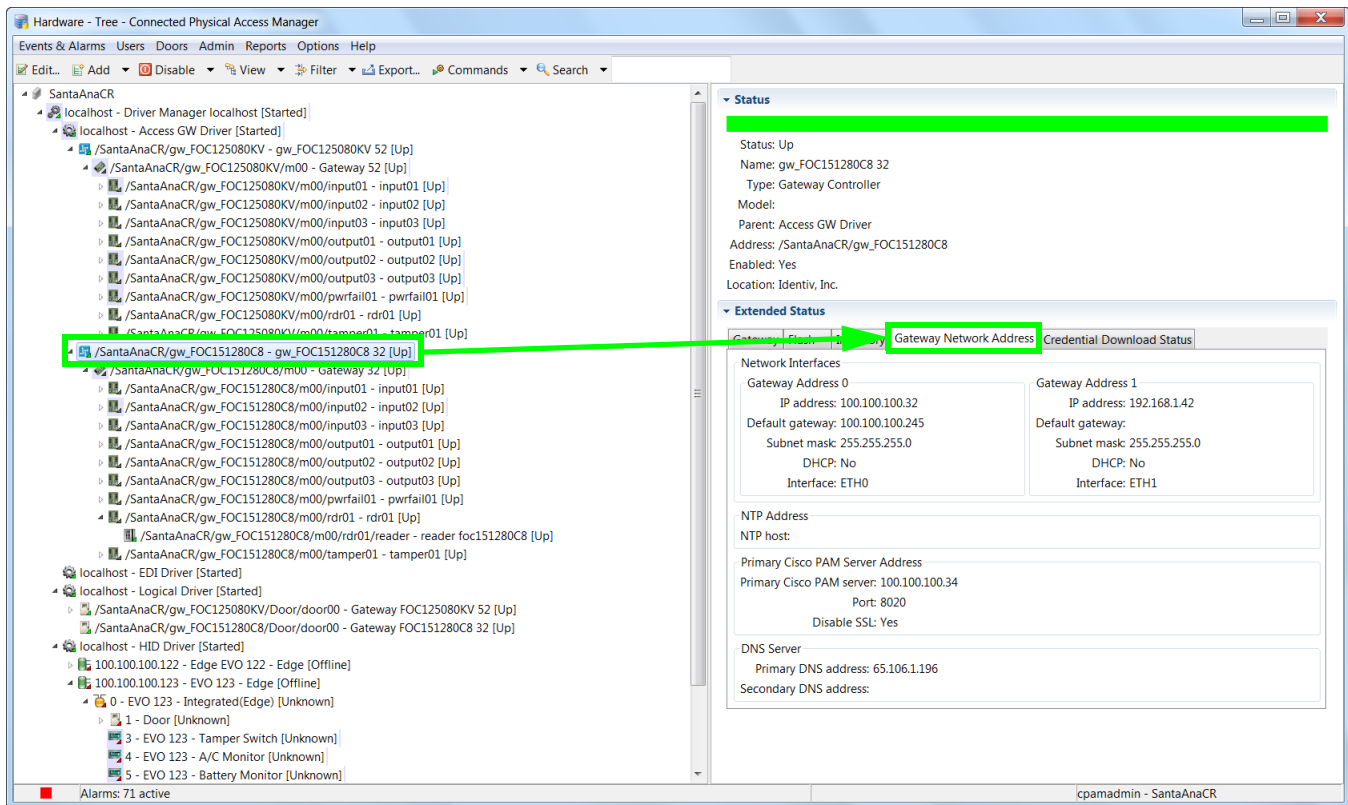

**Tip** The IP address is the address configured on the gateway Eth0 port address, which provides IP network connectivity with the ICPAM appliance.

**Step 3** Select the **Gateway Network Address** tab to display the module’s network configuration, including its gateway software (firmware) version number, as well as the IP address used for network communication.



# Changing the Gateway Network Settings

To change the network configuration settings for a gateway using ICPAM, right-click on a gateway and select **Set Gateway Address** from the pop-up menu.

## Procedure

- Step 1** Select the **Hardware - Tree** module from the **Doors** menu.
- Step 2** Expand the **Access GW Driver**.
- Step 3** Right-click on a gateway and select **Set Gateway Address** ([Figure C-2](#)).

**Tip** You can also change the gateway settings from the Door/Location-based Hardware module. Filter the display to view the gateways and then right-click a gateway name. See the [“Using Door/Location-based Hardware to Change Gateway Network Settings”](#) section on page C-10 for more information.

*Figure C-2 Set Gateway Address*

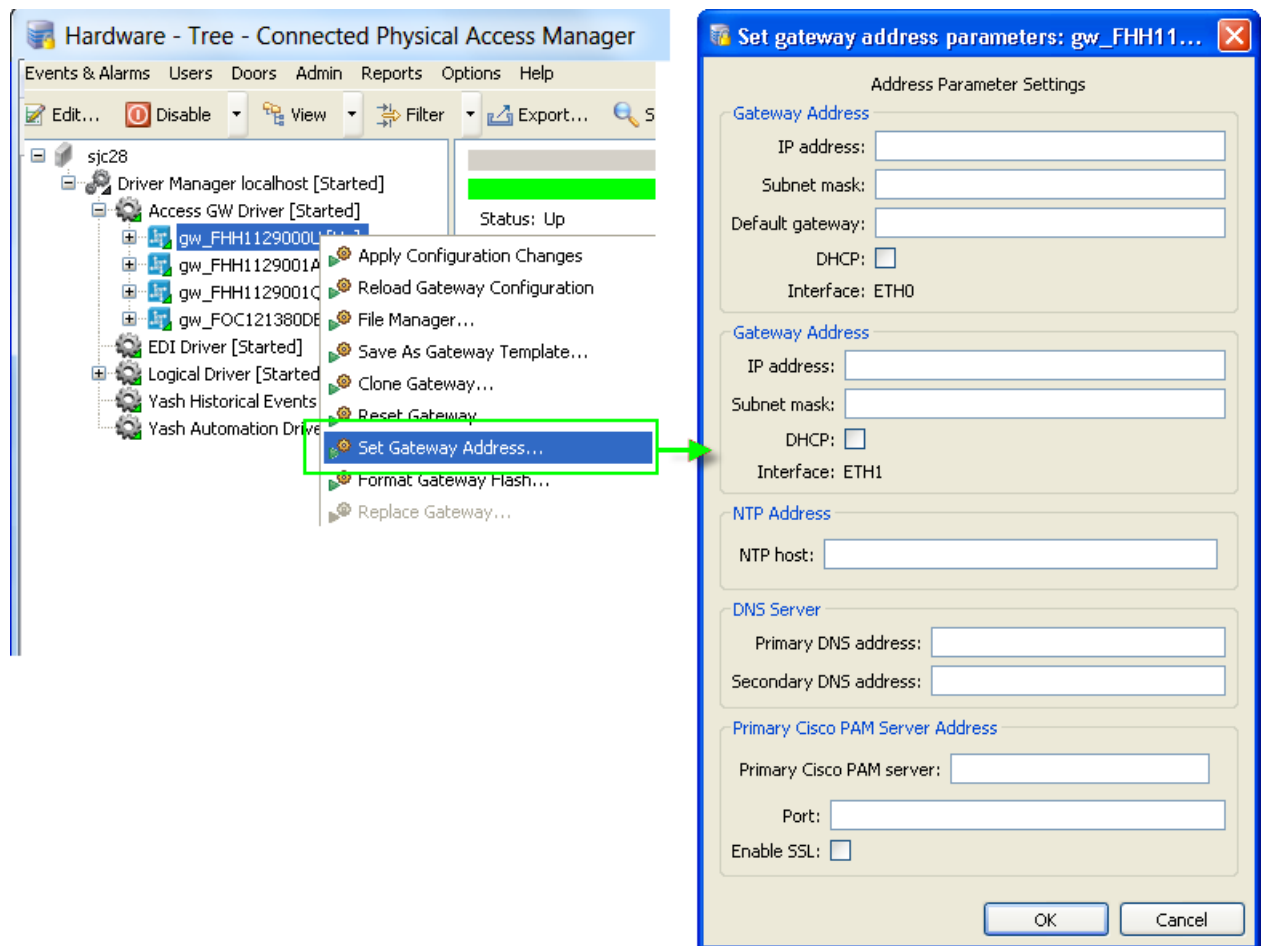

**Step 4** Modify the fields or options, as described in the following table.

| Field or Option                     | Description                                                                                                                                                                                                                                                                                                                                                                                                                                                                                                                                         |
|-------------------------------------|-----------------------------------------------------------------------------------------------------------------------------------------------------------------------------------------------------------------------------------------------------------------------------------------------------------------------------------------------------------------------------------------------------------------------------------------------------------------------------------------------------------------------------------------------------|
| <b>Gateway Address</b>              |                                                                                                                                                                                                                                                                                                                                                                                                                                                                                                                                                     |
| DHCP                                | If a Dynamic Host Configuration Protocol (DHCP) server is configured on your IP network, select the <b>DHCP</b> check box for ETH0 to automatically configure the required IP network settings, including IP address, Subnet Mask, and Gateway.                                                                                                                                                                                                                                                                                                     |
| IP Address                          | IP address for the module Ethernet interfaces. <ul style="list-style-type: none"> <li>The ETH0 interface provides IP network connectivity with the ICPAM appliance.</li> <li>The ETH1 interface is used for management connections, such as connecting a PC directly to the gateway.</li> </ul> See the <a href="#">Cisco Physical Access Gateway User Guide</a> for more information.                                                                                                                                                              |
| Subnet Mask                         | The subnet mask.                                                                                                                                                                                                                                                                                                                                                                                                                                                                                                                                    |
| Default Gateway                     | The IP address of the default network gateway.                                                                                                                                                                                                                                                                                                                                                                                                                                                                                                      |
| <b>NTP Address</b>                  |                                                                                                                                                                                                                                                                                                                                                                                                                                                                                                                                                     |
| NTP Host                            | The IP Address of a network time protocol (NTP) server used to set the gateway time. This setting is left blank if a DHCP server provides this setting.                                                                                                                                                                                                                                                                                                                                                                                             |
| <b>DNS Server</b>                   |                                                                                                                                                                                                                                                                                                                                                                                                                                                                                                                                                     |
| Primary DNS Address                 | Enter the Primary DNS Address configuration if names (not IP addresses) are used for the NTP or ICPAM addresses.                                                                                                                                                                                                                                                                                                                                                                                                                                    |
| Secondary DNS Address               | Enter the Secondary DNS Address configuration if names (not IP addresses) are used for the NTP or ICPAM addresses.                                                                                                                                                                                                                                                                                                                                                                                                                                  |
| <b>Primary ICPAM Server Address</b> |                                                                                                                                                                                                                                                                                                                                                                                                                                                                                                                                                     |
| Primary ICPAM Server                | Enter the ICPAM IP <b>Address</b> (IP address or name) to enable Gateway communication with the appliance.                                                                                                                                                                                                                                                                                                                                                                                                                                          |
| Port                                | Enter the <b>Port</b> number for the ICPAM appliance. The port number must be greater than 1024 and less 65535. The default is 8020.                                                                                                                                                                                                                                                                                                                                                                                                                |
| Enable SSL                          | The secure socket layer (SSL) is enabled for secure communication between the gateway and ICPAM appliance by default. If necessary SSL can be disabled by deselecting the <b>Enable SSL</b> check box. <p><b>Note</b> SSL is enabled by default on all gateways and ICPAM appliances. If SSL is disabled for a gateway but enabled for ICPAM, the gateway will not be able to connect to the appliance. If the SSL settings are changed, reset all gateways and the ICPAM appliance. We recommend enabling SSL to ensure secure communications.</p> |

**Step 5** Click **OK** to save the changes.

- Step 6** Right-click on the gateway and select **Apply Configuration Changes** to download configuration changes for a single gateway.



---

**Note** Gateways must be in the Up state, signified by a green triangle in the icon. A dark green triangle means there are configuration changes that have not been applied. See [Understanding Device Status Colors, page 5-15](#).

---

- Step 7** Verify that the new network settings appear in the Extended Status area, under the **Gateway Network Address** tab. See the “[Displaying the Gateway Network and Firmware Configuration](#)” section on [page C-2](#).
-

# Changing the NTP Setting for Multiple Gateways

You can set the network time protocol (NTP) server for all gateways, or for a selected gateway, to automatically synchronize the device time on the devices.

## Usage Notes

- We strongly recommend using the same NTP setting for the gateways and for the ICPAM appliance to ensure synchronized events and messaging. To set the server NTP address, see [Chapter 2, “Configuring and Monitoring the ICPAM Server”](#). Other systems that are integrated with ICPAM, such as the Video Surveillance Manager (Cisco VSM), should use the same NTP server setting.
- If the gateway is configured to receive an NTP server setting from DHCP, then the **Set NTP Server** command will not change the NTP server setting on that gateway.
- You can also enter a default NTP server address to pre-populate the server field in the **Set NTP Server** window. This setting is not applied to the gateways automatically. You must complete the instructions in the [“Change the NTP Setting for Multiple Gateways”](#) section on page C-8.

Refer to the following topics:

- [\(Optional\) Set a Default NTP Server, page C-6](#)
- [Change the NTP Setting for Multiple Gateways, page C-8](#)

## (Optional) Set a Default NTP Server

The default NTP server address pre-populates the NTP Server setting when updating multiple gateways. This default setting is optional, and is not applied to the gateways until you complete the instructions in the [“Change the NTP Setting for Multiple Gateways”](#) section on page C-8.

### Procedure

- 
- Step 1** Select **System Configuration** from the Admin menu.
  - Step 2** Select the **ICPAM Settings** tab.
  - Step 3** Enter the IP address in the NTP Server field ([Figure C-3](#)).





---

**Note** Enter an IP Address only. For example: 192.169.100.1. Hostnames are not supported.

---

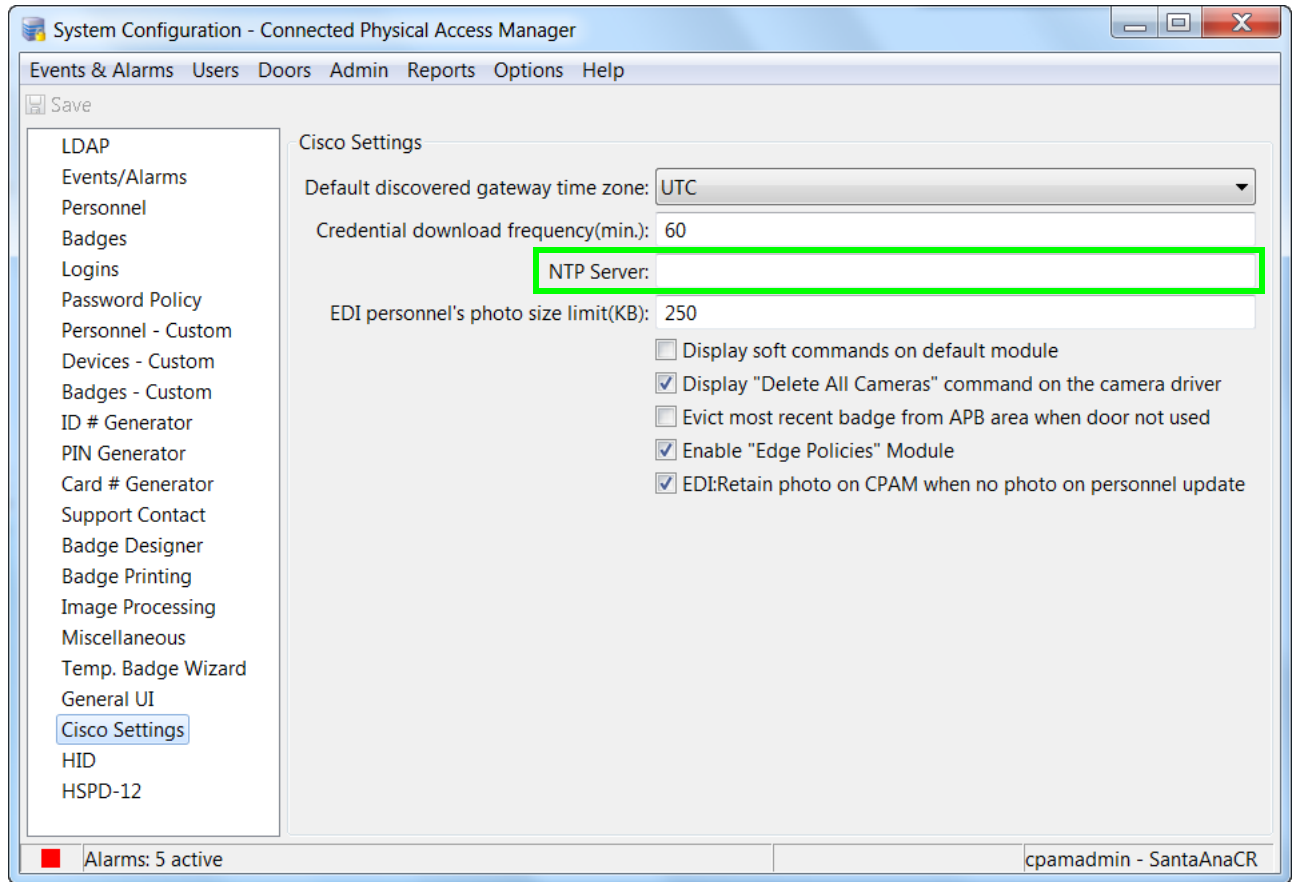
Figure C-3 System Configuration: NTP Server IP Address



**Step 4** Restart ICPAM (exit and relaunch the application).



**Note** Changes do not take effect until the ICPAM desktop application is restarted.

**Step 5** Continue to the following section: [“Change the NTP Setting for Multiple Gateways”](#) section on page C-8.

You must use the **Set NTP Server** command to apply the NTP server setting to one or more gateways.

## Change the NTP Setting for Multiple Gateways

Use the **Set NTP Server** command on the access gateway driver to configure the same NTP server IP Address on multiple gateways.



### Note

If the gateway is configured to receive an NTP server setting from DHCP, then the **Set NTP Server** command will not change the NTP server setting on that gateway.

### Procedure:

- Step 1** (Optional) Enter a default NTP server setting to auto-populate the NTP Server field. See the “(Optional) Set a Default NTP Server” section on page C-6 for more information.
- Step 2** Select **Hardware - Tree** from the **Doors** menu.
- Step 3** Right-click the **Access GW Driver** and select the **Set NTP Server** command (Figure C-4).

Figure C-4 Set NTP Server command for Multiple Gateways

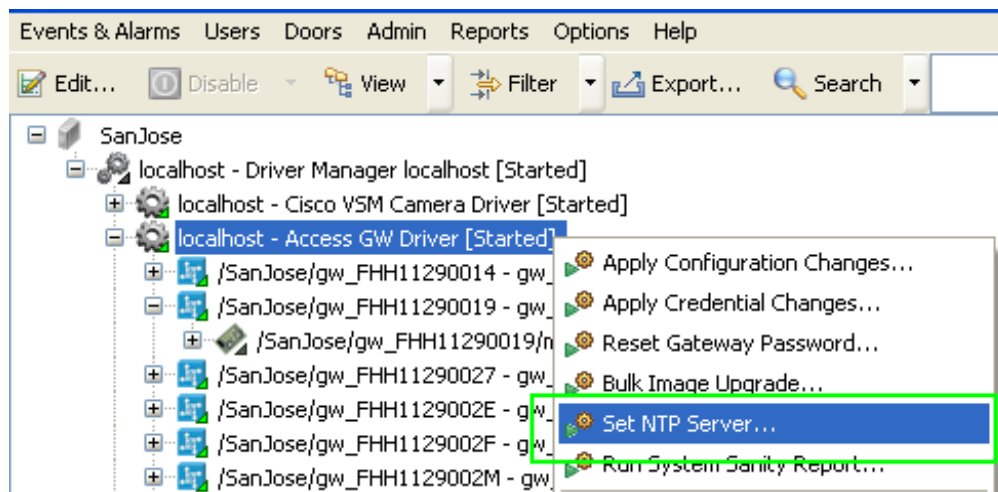

- Step 4** In the **Set NTP Server** dialog (Figure C-5), enter the following settings:
- Enter the NTP Server's IP address.



### Tip

If an NTP server address was entered in the System Configuration, that address appears by default. You can edit the address if necessary. See the “(Optional) Set a Default NTP Server” section on page C-6 for more information.

- Select **All Gateways** to select all available gateways. Only gateways in the UP state are displayed and available for NTP configuration.
- Select or deselect gateways in the list to include or exclude modules.

Figure C-5 Set NTP Server configuration window

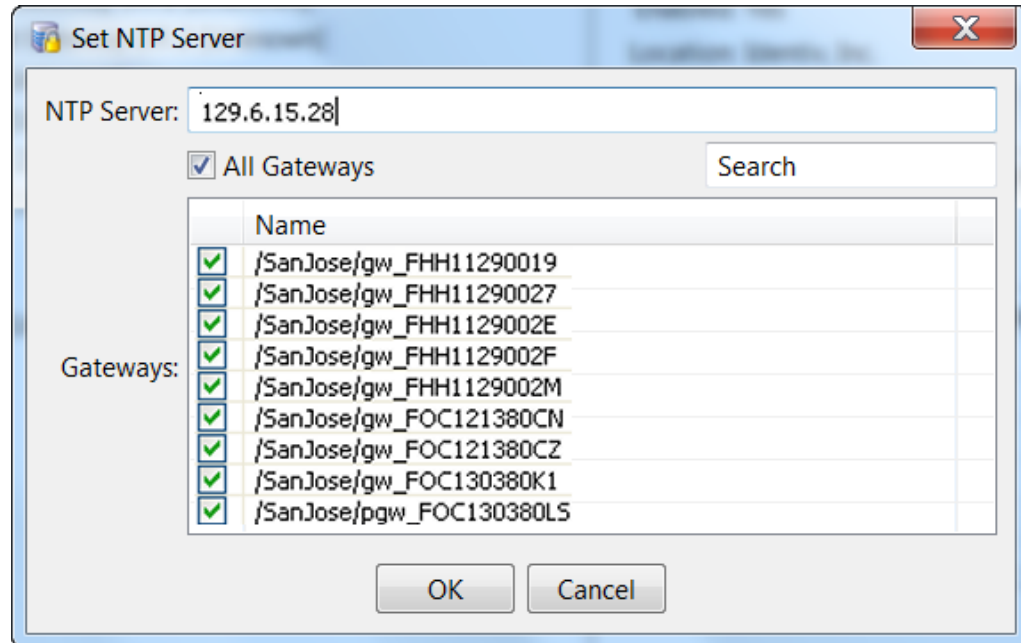

**Tip** Use the Search field to locate and display a specific module.

- Step 5** Click **OK** to save the changes.
- Step 6** Select **Yes** when the confirmation message appears. The approximate time that the command will take to execute appears.
- Step 7** Verify that the correct NTP Server IP address appears in the Extended Status area, under the **Gateway Network Address** tab. See the [“Displaying the Gateway Network and Firmware Configuration”](#) section on page C-2 for more information.



**Note** If the **Set NTP Server** command is already in progress for one or more gateways, you must wait for the summary event information to appear before you can use the command again.

## Using Door/Location-based Hardware to Change Gateway Network Settings

You can use either the Hardware - Tree module or the Door/Location-based Hardware module to perform gateway configuration tasks such as changing the network settings or configuring an NTP server for multiple gateways.

To use the Door/Location-based Hardware module, select **Gateway Controllers** from the **View** menu, as shown in [Figure C-6](#). The gateways are displayed according to their assigned location. Any gateways not assigned a location are listed under *Unassigned*.

**Figure C-6** Gateway Configuration Options in the Door/Location-based Hardware Module

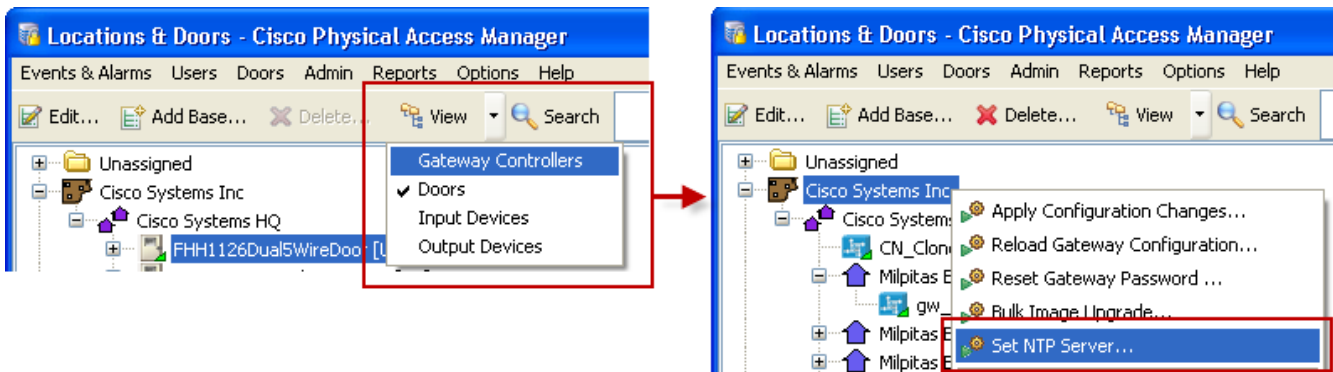

- Click a gateway icon to display the network configuration and software (firmware) version in the Extended Status area. See the [“Displaying the Gateway Network and Firmware Configuration”](#) section on page C-2 for more information.
- To change the network configuration for a single gateway, right-click the gateway icon and select **Set Gateway Address**. See the [“Changing the Gateway Network Settings”](#) section on page C-3 for additional instructions.
- To change the NTP server address for multiple gateways, right click a site icon and select **Set NTP Server**. See the [“Changing the NTP Setting for Multiple Gateways”](#) section on page C-6 for additional instructions.



# Upgrading Gateway Firmware Images Using ICPAM

Gateways must have the same firmware version as the ICPAM appliance server software. This includes the major version, minor version, maintenance version, and the build number. If any difference in versions exists between the gateway and the appliance, then only a restricted set of operations (such as image upgrade) can be performed.

For example, if the ICPAM appliance is upgraded to Release 2.2.0, then all gateways must also be upgraded to firmware Release 2.2.0. If the firmware release is different than the ICPAM appliance release, the gateway will not operate and the gateway status in the ICPAM Hardware - Tree module will be **Mismatch**.

To ensure the gateway firmware is the same release as the ICPAM appliance software version, complete the instructions in this section. You can upgrade all the gateways at the same time, or one gateway at a time.

Firmware images must be located on a TFTP server (such as the built-in ICPAM TFTP server). The firmware image file is then copied to the gateway from the TFTP server. Because gateways can store more than one firmware image, you must define which image is the active image, and then reset the gateway. When the module resets, the new firmware image is called the running image.

**Tip**

- To upgrade the firmware, activate a higher number release. To downgrade, activate a lower number release.
- You can also upgrade firmware using a PC directly connected to a gateway. See the *Cisco Physical Access Gateway User Guide* or the *ICPAM Installation Guide* for more information.

This section includes the following information:

- [Uploading Firmware Images to a TFTP Server, page C-11](#)
- [Updating the Firmware on All Gateways, page C-15](#)
- [Updating the Firmware on Individual Gateways, page C-21](#)

## Uploading Firmware Images to a TFTP Server

Firmware images used to update gateways must be located on a TFTP server. You can load the images to the built-in ICPAM TFTP server, or to another TFTP server as described in this section. If using the built-in TFTP server, that server must be running. See [Disabling the ICPAM TFTP Server, page D-2](#) for more information.

After the firmware has been copied to the TFTP server, you can load it to one or more gateways, as described in [Updating the Firmware on Individual Gateways, page C-21](#) and [Updating the Firmware on All Gateways, page C-15](#).

To load images to a TFTP server using Image Manager, do the following:

- Step 1** (Optional) Enable the built-in ICPAM TFTP server, if necessary.

**Note**

- The ICPAM TFTP server is enabled by default. Complete these steps only if the server was manually disabled, as described in [Disabling the ICPAM TFTP Server, page D-2](#).
- If you are using firmware images located on another TFTP server (not the ICPAM TFTP server), skip to [Step 2](#).

- Log in to the ICPAM Server Administration utility.  
See [Logging on to the ICPAM Server Administration Utility, page 2-2](#).
- Select the **Monitoring** tab and then select **Status**, as shown in [Figure C-7](#).
- If the TFTP Service is **Down**, click **Start**.
- Verify that the TFTP service is **Up**.

*Figure C-7 TFTP Service in “Up” State*

The screenshot shows the 'Connected PAM Server Administration' web interface. The 'Monitoring > Status' page displays the following information:

| Server                   |              |                                     |
|--------------------------|--------------|-------------------------------------|
| Admin State:             | Up           | <input type="button" value="Stop"/> |
| Server Mode:             | Active       |                                     |
| Version:                 | 2.0.0        |                                     |
| Serial Number:           | 000C29200881 |                                     |
| High Availability Audit: | disabled     |                                     |

| Services        |         |                                        |
|-----------------|---------|----------------------------------------|
| TFTP Service    | Up      | <input type="button" value="Stop"/>    |
| Web Service API | Enabled | <input type="button" value="Disable"/> |

The 'TFTP Service' row is highlighted with a green border. A 'Cisco Compatible' logo is visible in the bottom right corner of the interface.

**Step 2** Log in to the ICPAM desktop client.

See [Logging on to the ICPAM Server Administration Utility, page 2-2](#).

**Step 3** Select **Image Manager** from the **Admin** menu.

[Figure C-8](#) shows the Image Manager window. [Table C-1 on page C-13](#) describes each field.

Figure C-8 Image Manager with Callouts

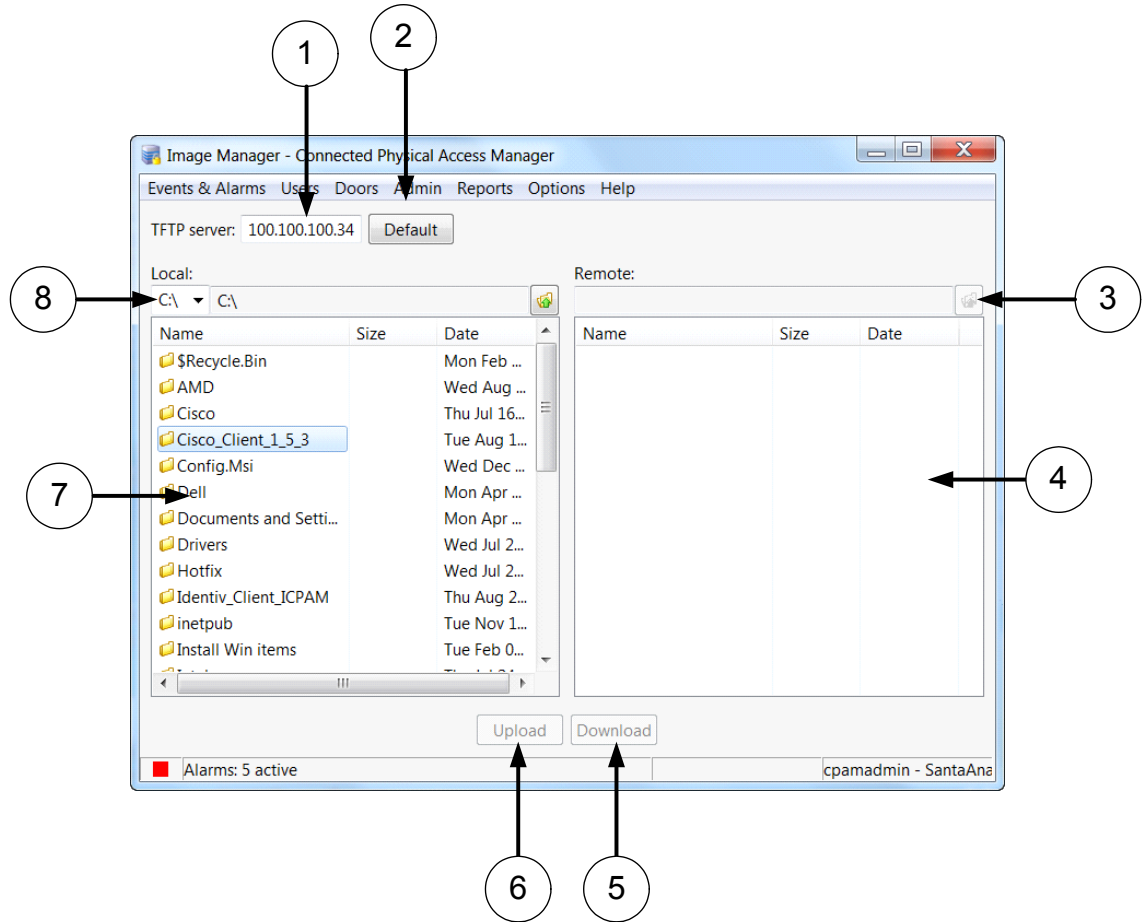

Table C-1 Image Manager Fields

| # | Field                 | Description                                                                                                                                                                                                                                                                                                                                                                                                                                                                                                                                                                                                                                                                                                                                                                          |
|---|-----------------------|--------------------------------------------------------------------------------------------------------------------------------------------------------------------------------------------------------------------------------------------------------------------------------------------------------------------------------------------------------------------------------------------------------------------------------------------------------------------------------------------------------------------------------------------------------------------------------------------------------------------------------------------------------------------------------------------------------------------------------------------------------------------------------------|
| 1 | TFTP server           | The IP address of the TFTP server to store image files.                                                                                                                                                                                                                                                                                                                                                                                                                                                                                                                                                                                                                                                                                                                              |
| 2 | Default               | Click this button to IP address for the ICPAM TFTP server in the <b>TFTP server</b> field.                                                                                                                                                                                                                                                                                                                                                                                                                                                                                                                                                                                                                                                                                           |
| 3 | Remote Directory Path | <p>The directory path on the TFTP server where files will be uploaded. The directory is in relation to the TFTP server root directory.</p> <ul style="list-style-type: none"> <li>If using the built-in ICPAM TFTP server, this field is read-only. Select the directory path using the <b>Remote Browser</b>.</li> <li>If using a TFTP server other than the build-in ICPAM server, this field is editable and you must enter the directory path on the TFTP server where files will be uploaded. The directory path must be valid since ICPAM does not validate remote server directories.</li> </ul> <p><b>Note</b> If this field is empty the image file is uploaded to the TFTP root directory. The default TFTP root directory is <code>/tftpboot</code> for Unix systems.</p> |

Table C-1 Image Manager Fields (continued)

| # | Field                       | Description                                                                                                                                                                                                                                                                                                                                                                                                                                                              |
|---|-----------------------------|--------------------------------------------------------------------------------------------------------------------------------------------------------------------------------------------------------------------------------------------------------------------------------------------------------------------------------------------------------------------------------------------------------------------------------------------------------------------------|
| 4 | <b>Remote Browser</b>       | Selects the directory where files will be uploaded on the built-in ICPAM TFTP server. This field is active only if you are using the built-in ICPAM server.<br><br>Right-click within the field to display and select the following menu options: <ul style="list-style-type: none"> <li>• <b>Create Directory</b>: Creates a directory.</li> <li>• <b>Delete File/Directory</b>: Enabled when a file or directory is selected. Deletes the file or directory</li> </ul> |
| 5 | <b>Download Button</b>      | Download a selected image on the TFTP server to the local drive.                                                                                                                                                                                                                                                                                                                                                                                                         |
| 6 | <b>Upload Button</b>        | Uploads the selected image file to the specified TFTP server and directory. This button is enabled only when a file is selected in the Local directory browser.                                                                                                                                                                                                                                                                                                          |
| 7 | <b>Local Image Browser</b>  | The <b>Local</b> directory browser specifies the file on a local drive for upload to the TFTP server. <ul style="list-style-type: none"> <li>• Click the <b>Up</b> button to navigate one level up.</li> <li>• Double-click a folder to view the folder contents.</li> <li>• Select a file to enter the file name and directory path in the <b>Local Directory Path</b> field and enable the <b>Upload</b> button.</li> </ul>                                            |
| 8 | <b>Local Directory Path</b> | Read-only. Displays the directory path and filename for the file selected in the <b>Local</b> browser. This file will be uploaded to the specified TFTP server.                                                                                                                                                                                                                                                                                                          |

**Step 4** Upload firmware images to either the ICPAM TFTP server or another TFTP server:

**Uploading images to the ICPAM TFTP Server:**

- a. Click **Default** to enter the ICPAM TFTP server IP address in the **TFTP server** field.
- b. Select the file to be uploaded from the **Local** file browser. The selected file is automatically entered in the **Local Image File** field.
- c. Use the **Remote Browser** to select the directory on the ICPAM TFTP server where files will be uploaded. This field is inactive if you are using a TFTP server other than the built-in ICPAM server.  
Right-click within the **Remote Browser** to select the following menu options:
  - **Create Directory**: Creates a new directory on the ICPAM TFTP server.
  - **Delete File/Directory**: Deletes a selected file or directory.
- d. Click **Upload** to add the file to the TFTP server specified in the **TFTP server** field.

**Uploading Images to a Different TFTP Server (Not the ICPAM TFTP Server):**

- a. Enter the server IP address in the **TFTP server** field.
- b. In the **Remote Directory** field, enter the TFTP server directory path where the image will be stored. If this field is left blank, then the root TFTP directory is used by default. The default Unix TFTP root directory is `/tftpboot`.



---

**Note** The TFTP server directory path entered in the **Remote Directory** field must be valid. ICPAM does not validate the existence of remote server directories.

---

- c. In the **Local** file browser field, select the firmware file on a local drive to be uploaded. The directory path and filename are displayed in the **Image File** field.
- d. Click **Upload** to add the file to the TFTP server specified in the **TFTP server** field.

**Step 5** Continue to [Updating the Firmware on Individual Gateways, page C-21](#).



---

**Tip** To download an image from the TFTP server to a local directory, select the image and local directory, then click the **Download** button.

---

## Updating the Firmware on All Gateways

This section describes how to upgrade or downgrade all the gateways configured in an ICPAM server.



---

**Tip** To upgrade the firmware for a single gateway, see [Updating the Firmware on Individual Gateways, page C-21](#).

---

### Before You Begin

Review the following before upgrading the gateways.

- This procedure loads the same firmware image to all gateways configured in ICPAM. If you check the options **Set as active image** and **Reset Gateway**, the gateways will reset with the new image as the active *running* image.
- An *Active* image is the image that will be operational when the gateway is reset. A *Running* image is the firmware image currently used to operate the gateway.
- Gateways must have the same firmware version as the ICPAM appliance server software. This includes the major version, minor version, maintenance version, and the build number. If any difference in versions exists between the gateway and the appliance, then only a restricted set of operations (such as image upgrade) can be performed.
- Gateways operate normally while the firmware image is being copied from the TFTP server, but are out of service while being reset. When a gateway is down, the doors for that gateway remain locked if the lock is fail-secure, and unlocked otherwise. See [Understanding Door Modes, Door Schedules, and the First Unlock Feature, page 5-28](#) for more information.
- If you deselect the options **Set as active image** and **Reset Gateway**, then the firmware image is copied to the gateways, but is not made the *Active* or *Running* image. You must use the File Manager to manually activate the image on each gateway, as described in [Step 9](#), and then reset the gateway as described in [Step 10](#).
- Review the recommendations in the “[Select the Following Options When Upgrading Gateway Firmware](#)” section on [page B-6](#).
- Gateways not configured in ICPAM are not impacted by this procedure.
- Gateways are upgraded in batches of 5, with a 15 minute delay between batches.

- 10 minutes after all the gateways are updated, a summary event is posted to ICPAM. Any gateways that are still in the Issued state are described as upgrade still in progress.
- You cannot issue another **Bulk Image Upgrade** command until the summary event is posted.

### Procedure

To upgrade or downgrade the firmware images for all gateways, complete the following steps.

- 
- Step 1** Complete the instructions in [Uploading Firmware Images to a TFTP Server, page C-11](#)
- Step 2** Log in to the ICPAM desktop client.  
See [Logging into the ICPAM Client, page 3-3](#).
- Step 3** Select **Hardware - Tree** from the **Doors** menu.
- Step 4** Right-click the **Access GW Driver** and select **Bulk Image Upgrade** ([Figure C-9](#)).

*Figure C-9 Bulk Image Upgrade Menu*

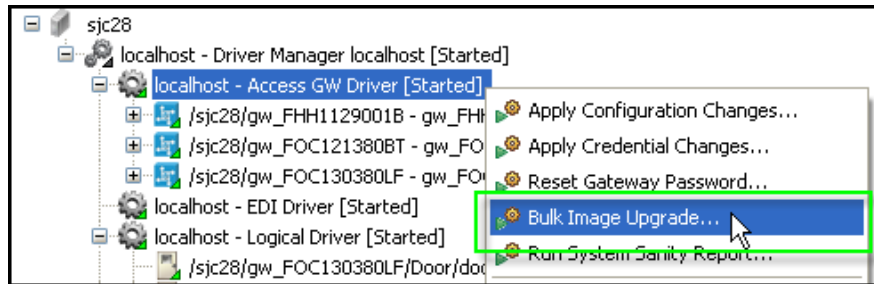

### Tip

You can also access the **Bulk Image Upgrade** command using the **Door/Location-based Hardware** module. Select **Door/Location-based Hardware** from the **Doors** menu, and then select **Gateway Controllers** from the **View** menu. Right-click a location or site and select **Bulk Image Upgrade** from the menu.

- 
- Step 5** In the Bulk Image Upgrade window ([Figure C-10](#)), enter the image location and select the upgrade options.
- Enter the **Image Name**.
    - If the image is located on the ICPAM TFTP server, click **Browse** to select a firmware image name.
    - If the image is located on a different TFTP server, enter the filename manually.

Figure C-10 Bulk Image Upgrade Window

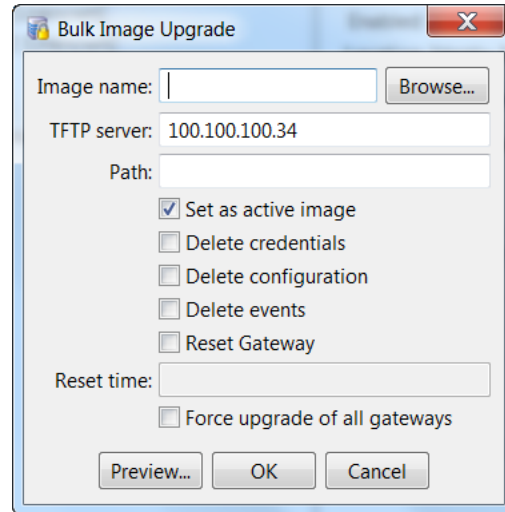

- b. Enter the **TFTP server** IP address.  
The ICPAM appliance TFTP server IP address is entered by default.
- c. Enter the directory **Path** on the TFTP server for the firmware image.
  - Leave this field blank if using the default location for the built-in ICPAM TFTP server.
  - Be sure the path and filename are valid. The administration tool does not verify remote server paths.
- d. Select the following options to define what that will occur after the image is loaded to the gateway:
  - **Set as active image:** (checked by default) make the firmware file new Active image for all gateways. The active image is the firmware that will become the running image when the gateway is reset (see [Figure C-14](#)).
  - **Delete credentials:** delete the credentials on all gateways.
  - **Delete configuration:** delete the module configuration on all gateways. The configuration is automatically reloaded when the module establishes communication with the ICPAM appliance.
  - **Delete events:** delete all events stored on all gateways.
  - **Reset Gateway:** perform a soft reset to powercycle all gateways. Resetting the gateway changes the active image to the running image. All gateways will be down during the reset. Uncheck this box to reset the gateways individually.
  - **Reset time:** enter the time in 24-hour notation that the gateways will begin to reset with the new firmware image. If this field is left blank, the gateways will begin to reload in batches of 5 when you click **OK**.
  - **Force upgrade of all gateways:**



**Note** See the “[Select the Following Options When Upgrading Gateway Firmware](#)” section on [page B-6](#).

- Step 6** Click **OK** to close the window and begin copying the firmware image to the gateways.
- Any actions selected in [Step 5d](#) are initiated. For example, the default option **Set as active image** makes the new image Active. The gateways must still be reset for the image to become the Running image.
  - Gateways are upgraded in batches of 5, with a 15 minute delay between batches.
  - When all options are selected, wait an additional 10-15 minutes for the firmware upgrade to complete on each gateway.

**Note**

If you did not check the **Reset Gateway** option, the firmware image is copied to the gateways and defined as Active, but is not made the Running image. See [Step 10](#) and [Step 9](#) to manually activate the image and reset each gateway.

- Step 7** Verify the upgrade status.
- In the **Hardware - Tree** module, select the **Access GW Driver**.
  - In the **Extended Status** field for the driver, select the **Command Status** tab, as shown in [Figure C-11](#).

**Figure C-11** Bulk Image Upgrade Status

The screenshot shows the ICPAM software interface. On the left is a tree view under 'Blr' containing several drivers. The 'Access GW Driver' is selected. The main panel on the right shows the 'Status' and 'Extended Status' tabs. The 'Extended Status' tab is active, displaying a table with columns: Name, Status, Description, Start Time, and End Time. The table contains three rows of data for gateway upgrades. A green box highlights the 'Bulk Image Upgrade' entry, and a green arrow points to it from the left.

| Name               | Status    | Description           | Start Time                   | End Time                    |
|--------------------|-----------|-----------------------|------------------------------|-----------------------------|
| Bulk Image Upgrade |           |                       |                              |                             |
| Sjc_gateway        | FAILED    | Image Download Failed | Wed Dec 30 16:22:06 IST 2009 | Wed Dec 30 13:52:23 IST ... |
| Gateway            | ISSUED    |                       | Wed Dec 30 16:22:07 IST 2009 |                             |
| Blr_gateway        | SUCCEEDED | Image Download Passed | Wed Dec 30 16:22:06 IST 2009 | Wed Dec 30 13:50:57 IST ... |

- Expand the **Bulk Image Upgrade** entry to view the upgrade status for each gateway. The possible states include the following:
  - ISSUED**: The upgrade command was issued to the gateway.
  - SUCCEEDED**: The gateway image upgrade was successfully completed.
  - FAILED**: The gateway image upgrade Failed for the reason in the description.
  - COMPLETED**: ICPAM cannot determine if the upgrade SUCCEEDED or FAILED. Completed indicates the command execution is complete, but you must manually verify the success or failure of the image upgrade using the File Manager.



**Note**

The status is shown as **COMPLETED** if the gateway reboots while the status is still **ISSUED**. This can happen if the gateway has a large number of events in its queue when the module reboots, so the final status is not reported. Right-click the gateway icon in the **Hardware - Tree** module and select **File Manager** to view the status of the loaded firmware images.

**Step 8** Review the summary event posted to the ICPAM Events module.

- a. Select **Events** from the **Events & Alarms** menu, under the **Monitoring** submenu.
- b. Double click the summary event to view details of the bulk image upgrade, as shown in [Figure C-12](#).

**Figure C-12** Summary Event for Bulk Upgrade Command

The screenshot shows the 'Events - Connected Physical Access Manager' window. The main window displays a list of events with columns for Time, Description, Device, Personnel Record, Credential, and Data. A green box highlights the event 'Gateway Driver command...' at 8/24/2015 14:21:55. A green arrow points from this event to a 'View - Device Command Result' dialog box. The dialog box shows details for the command, including Time, Site, Type, Log code, Priority, Description, Device, Credential, Personnel record, Data, Command, and Target device.

| Time               | Description                 | Device          | Personnel Record | Credential | Data                   |
|--------------------|-----------------------------|-----------------|------------------|------------|------------------------|
| 8/24/2015 15:54:57 | Workstation: Logged In      | MaryJo-Opti9020 |                  |            |                        |
| 8/24/2015 15:54:57 | Operator logged in          | MaryJo-Opti9020 |                  | cpadmin    |                        |
| 8/24/2015 15:50:04 | Operator logged out         | MaryJo-Opti9020 |                  | cpadmin    |                        |
| 8/24/2015 15:40:51 | Credential records group... |                 |                  |            | Total: 3; Processed... |
| 8/24/2015 14:21:55 | Gateway Driver command...   | MaryJo-Opti9020 |                  | cpadmin    |                        |
| 8/24/2015 14:21:42 | Gateway Driver command...   | MaryJo-Opti9020 |                  | cpadmin    |                        |
| 8/24/2015 13:28:38 | Workstation: Logged In      | CPAM-PC         |                  |            |                        |
| 8/24/2015 13:28:38 | Operator logged in          | CPAM-PC         |                  | cpadmin    |                        |
| 8/24/2015 13:06:40 | Gateway Controller comm...  | MaryJo-Opti9020 |                  | cpadmin    |                        |
| 8/24/2015 10:26:42 | Operator logged out         | CPAM-PC         |                  | cpadmin    |                        |
| 8/24/2015 10:26:42 | Workstation: Logged Out     | CPAM-PC         |                  |            |                        |
| 8/21/2015 13:31:50 | HID Controller command: ... | MaryJo-Opti9020 |                  |            |                        |
| 8/21/2015 13:30:11 | HID Driver: Started         | HID Driver      |                  |            |                        |
| 8/21/2015 13:30:11 | HID Controller: Offline     | EVO 1 - Edge    |                  |            |                        |
| 8/21/2015 13:30:09 | HID Driver: Starting        | HID Driver      |                  |            |                        |
| 8/21/2015 13:30:09 | Driver command: Start       | MaryJo-Opti9020 |                  |            |                        |
| 8/21/2015 13:30:06 | HID Driver: Stopped         | HID Driver      |                  |            |                        |
| 8/21/2015 13:30:06 | HID Driver: Stopping        | HID Driver      |                  |            |                        |
| 8/21/2015 13:30:06 | Driver command: Stop        | MaryJo-Opti9020 |                  |            |                        |
| 8/21/2015 13:29:13 | HID Driver: Started         | HID Driver      |                  |            |                        |
| 8/21/2015 13:29:13 | HID Controller: Offline     | EVO 1 - Edge    |                  |            |                        |
| 8/21/2015 13:29:12 | HID Driver: Starting        | HID Driver      |                  |            |                        |
| 8/21/2015 13:29:12 | HID Driver: Stopped         | HID Driver      |                  |            |                        |
| 8/21/2015 13:29:12 | HID Driver: Stopping        | HID Driver      |                  |            |                        |
| 8/21/2015 13:29:12 | Driver command: Restart     | MaryJo-Opti9020 |                  |            |                        |

**View - Device Command Result**

Report...

Time: 12/30/2009 16:32:07.000

Time received: 12/30/2009 16:32:07.000

Site: Blr

Type: Device Command Result

Log code: GW.DCR\_GW\_BULK\_IMG\_UPGRADE.OK

Priority: 0

Description: Gateway Driver command succeeded: Bulk Image Upgrade

Device: nachutha-wxp02 [Edit... View Status...]

Credential: cpadmin [Edit...]

Personnel record: [Edit... View Photo...]

Data: Upgrade successful gateway(s): 1; Upgrade failed gateway(s): 1; Upgrade inprogress gatewa

Command: Bulk Image Upgrade

Target device: Access GW Driver [Edit...]

**Note**

- The summary event is posted 10 minutes after all the gateways are updated.
- Any gateways that are still in the **Issued** state are shown as **Upgrade in progress** in the Data field.
- You cannot issue another **Bulk Image Upgrade** command until after the summary event is posted.

**Step 9** (Optional) Use the File Manager to verify the active and running firmware image for a gateway.



**Tip** You can also change the active image using the File Manager.

- a. Right-click a gateway (blue icon) and select **File Manager**, as shown in [Figure C-13](#).

**Figure C-13** File Manager command

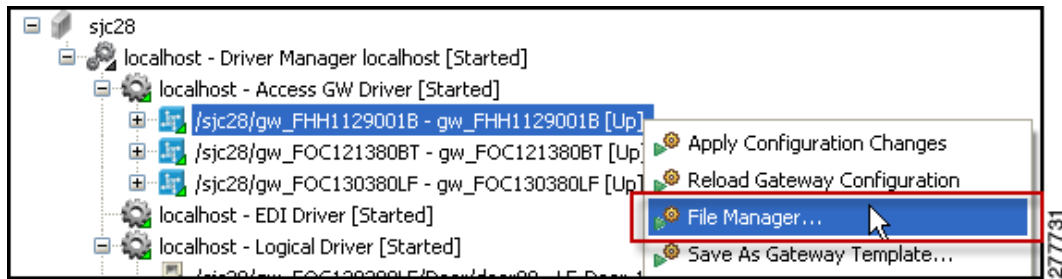

- b. Select the **Image** tab to display a list of the firmware images currently loaded on the gateway, as shown in [Figure C-14](#).

**Figure C-14** File Manager Window: Image Tab

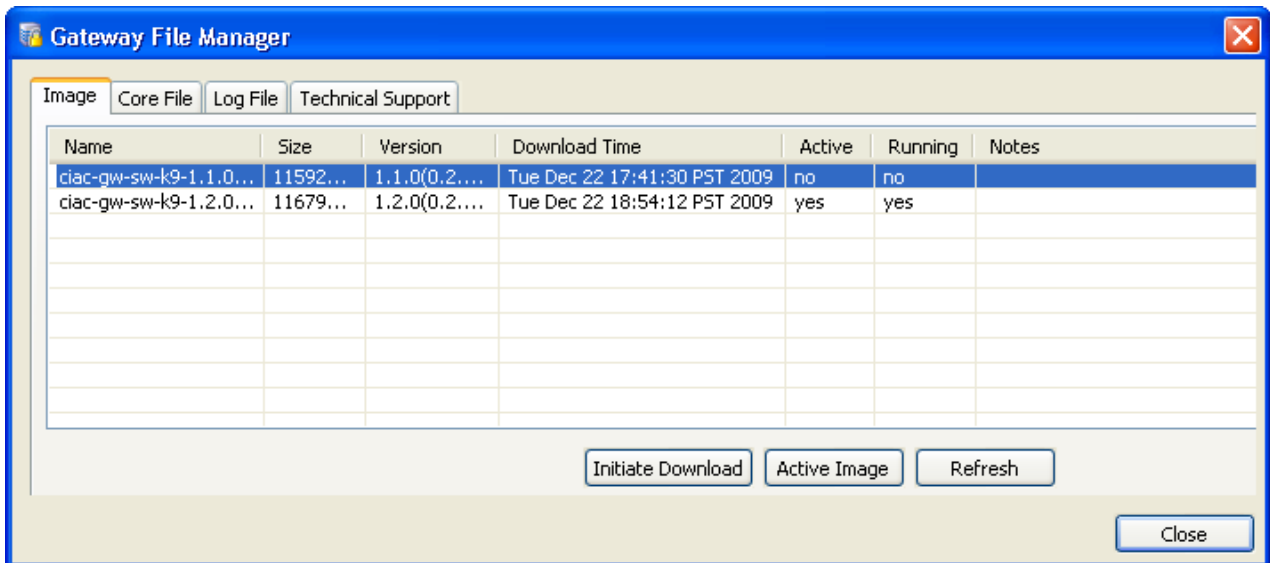

Each row displays the following information about the firmware image:

- **Name:** the image filename.
- **Version:** the firmware version number.
- **Download Time:** the time and date when the image was downloaded to the gateway.
- **Active:** The active image will become the running image when the gateway is reset. The image marked **Yes** is the active image on the gateway.
- **Running:** The running image is the image currently used to operate the gateway. The image marked **Yes** is the current running image on the gateway.

- c. To change the active image, select an image name and click the **Active Image** button.  
This button is available only if the selected file is not the Active image.
- d. To make the active image the running image, you must reset the gateway. Right-click on the gateway icon and select **Reset Gateway**, as described in [Step 10](#).
- e. Click **Close** to accept the changes and close the window.

**Step 10** (Optional) Reset individual gateways.

This step is necessary if you did not select the option to **Reset Gateway** in [Step 5d](#). The *Active* image becomes the running image only after the gateway is reset.

To reset the gateway, right-click a gateway (blue icon) in the **Hardware - Tree** module, and choose the **Reset Gateway** command, as shown in [Figure C-15](#).

**Figure C-15** Reset Gateway Command

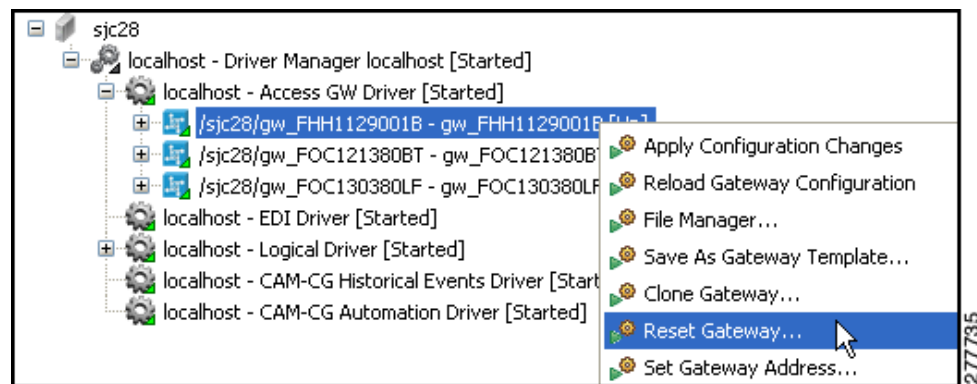

## Updating the Firmware on Individual Gateways

You can load more than one firmware image to a gateway, and then upgrade or downgrade the firmware by selecting the *active* image and resetting the gateway. Select a higher release to upgrade the firmware, or a lower release to downgrade.



**Note** This section includes instructions for individual gateways. To upgrade the firmware for all gateways, see [Updating the Firmware on All Gateways, page C-15](#).

### Before You Begin

Review the following before using the instructions to upgrading an individual gateway.

- This procedure loads the same firmware image to all gateways configured in ICPAM. If you check the options **Set as active image** and **Reset Gateway**, the gateways will reset with the new image as the active *running* image.
- An *Active* image is the image that will be operational when the gateway is reset. A *Running* image is the firmware image currently used to operate the gateway.

- Gateways operate normally while the firmware image is being copied from the TFTP server, but are out of service while being reset. When a gateway is down, the doors for that gateway remain locked if the lock is fail-secure, and unlocked otherwise. See [Understanding Door Modes, Door Schedules, and the First Unlock Feature](#), page 5-28 for more information.
- If you deselect the options **Set as active image** and **Reset Gateway**, then the firmware image is copied to the gateway, but is not made the *Active* or *Running* image. You must use the File Manager to manually activate the image on each gateway, as described in [Step 8](#), and then reset the gateway, as described in [Step 9](#).
- Review the recommendations in the “[Select the Following Options When Upgrading Gateway Firmware](#)” section on page B-6.

### Procedure

- 
- Step 1** Complete the instructions in [Uploading Firmware Images to a TFTP Server](#), page C-11
- Step 2** Log in to the ICPAM desktop client.  
See [Logging into the ICPAM Client](#), page 3-3.
- Step 3** Select **Hardware - Tree** from the **Doors** menu.
- Step 4** Right-click a gateway (blue icon) and select **File Manager** ([Figure C-16](#)).

*Figure C-16 File Manager command*

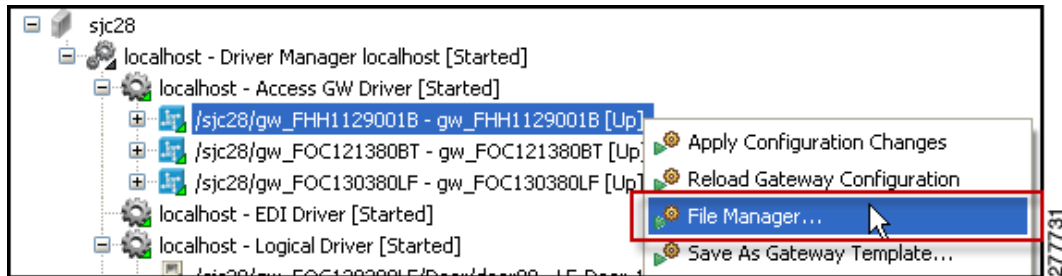

#### Tip

You can also access the **File Manager** using the **Door/Location-based Hardware** module. Select **Door/Location-based Hardware** from the **Doors** menu, and then select **Gateway Controllers** from the **View** menu. Expand a location tree and right-click a gateway to select **File Manager** from the menu.

- 
- Step 5** Select the **Image** tab to display a list of the firmware images currently loaded on the gateway ([Figure C-17](#)).

Figure C-17 File Manager Window: Image Tab

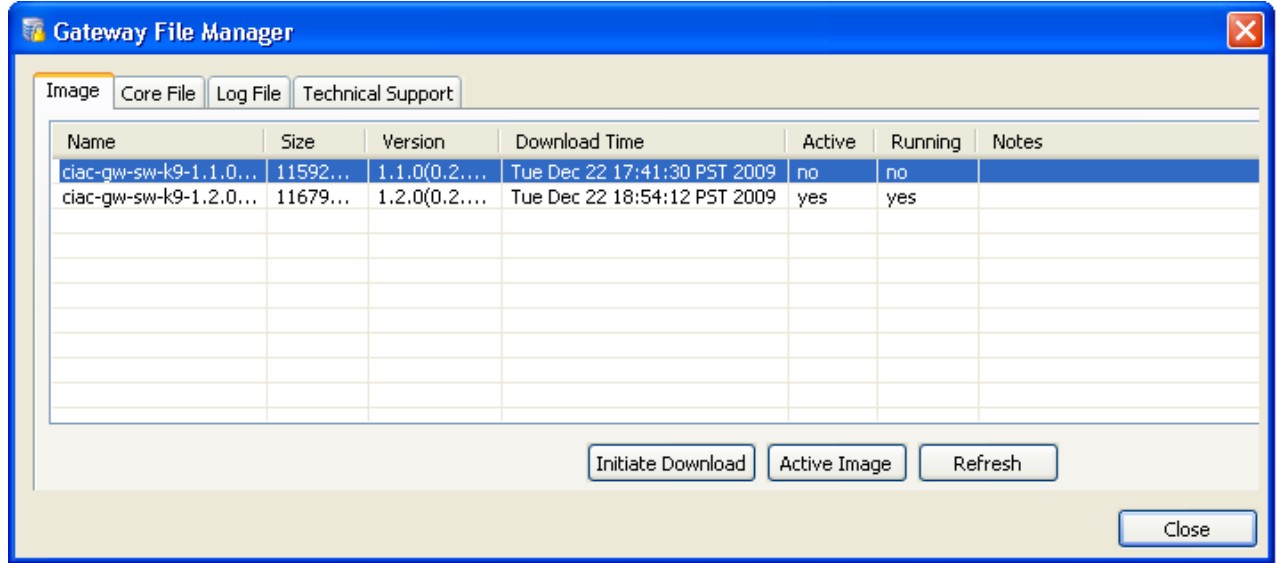

Each row displays information about the firmware image:

- **Name:** the image filename.
- **Version:** the firmware version number.
- **Download Time:** the time and date when the image was downloaded to the gateway.
- **Active:** The Active image will become the Running image when the gateway is reset. The image marked **Yes** is the active image on the gateway.
- **Running:** The Running image is the image currently used to operate the gateway. The image marked **Yes** is the current running image on the gateway.

- Step 6** Download a new firmware image from a TFTP server, if necessary:
- a. Click the **Initiate Download** button, as shown in [Figure C-17](#).  
The Initiate Download Input dialog appears, as shown in [Figure C-18](#).

*Figure C-18 Initiate Download Input dialog*

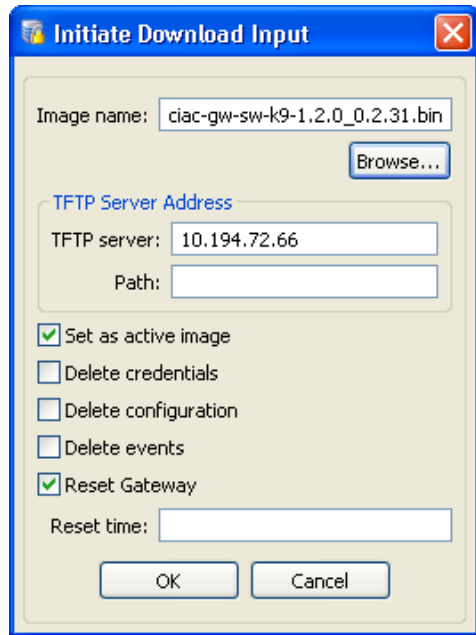

- b. Enter the **Image name**:
  - If the image is located on the ICPAM TFTP server, click **Browse** ([Figure C-18](#)) to select a firmware image name.
  - If the image is located on a different TFTP server, enter the filename manually.
- c. Enter the **TFTP Server** IP address.  
The ICPAM appliance TFTP server IP address is entered by default.
- d. Enter the directory **Path** on the TFTP server for the firmware image.
  - Leave this field blank if using the default location for the built-in ICPAM appliance TFTP server.
  - Be sure the path and filename are valid. The administration tool does not verify remote server paths.
- e. Select the following options to define what that will occur after the image is loaded to the gateway:
  - **Set as active image**: (checked by default) make the firmware file new active image. The Active image is the firmware that will become the Running image when the gateway is reset
  - **Delete credentials**: delete the credentials on this gateway.
  - **Delete configuration**: delete the module configuration. The configuration is automatically reloaded when the module establishes communication with the ICPAM appliance.
  - **Delete events**: delete all events stored on the module.

- **Reset Gateway:** (checked by default) perform a soft reset to powercycle the module. Resetting the gateway changes the Active image to the Running image. The gateway will be down during the reset. Uncheck this box to reset the gateways manually, as described in [Step 9](#).
- **Reset time:** defines when the gateway reset will occur. If this field is left blank, the gateway resets immediately after the image is downloaded to the gateway. You can also enter a time (in 24-hour notation) when the gateway should reset. This field is used only if the **Reset Gateway** option is checked.



**Note** See the “[Select the Following Options When Upgrading Gateway Firmware](#)” section on [page B-6](#).

- Step 7** Click **OK** to close this dialog and copy the firmware image to the gateway.
- Any actions selected in [Step 6e](#) are initiated. For example, the new active image is set and the gateway is reset (the gateway must be reset to activate the new image).
  - When all options are selected, wait approximately 10-15 minutes for the firmware upgrade to complete.
- Step 8** Click **Refresh** in the File Manager window to refresh the information and verify the Active and Running firmware image (see [Figure C-19](#)).

*Figure C-19 File Manager Window: Image Tab*

| Name                   | Size     | Version      | Download Time                | Active | Running | Notes |
|------------------------|----------|--------------|------------------------------|--------|---------|-------|
| ciac-gw-sw-k9-1.1.0... | 11592... | 1.1.0(0.2... | Tue Dec 22 17:41:30 PST 2009 | no     | no      |       |
| ciac-gw-sw-k9-1.2.0... | 11679... | 1.2.0(0.2... | Tue Dec 22 18:54:12 PST 2009 | yes    | yes     |       |

Each row displays the following information:

- **Name:** the image filename.
- **Version:** the firmware version number.
- **Download Time:** the time and date when the image was downloaded to the gateway.
- **Active:** The Active image will become the Running image when the gateway is reset. The image marked **Yes** is the Active image on the gateway.
- **Running:** The Running image is the image currently used to operate the gateway. The image marked **Yes** is the current Running image on the gateway.

- f. (Optional) To change the active image, select an image and click the **Active Image** button.

This button is available only if the selected file is not the active image. The Active image does not become the Running image until the gateway is reset.

- g. Click **Close** to accept the changes and close the window.

**Step 9** (Optional) Reset the gateway.

This step is necessary if you did not select the option to **Reset Gateway** in [Step 6e](#), or want to change the Running image. The *Active* image becomes the *Running* image only after the gateway is reset.

To reset the gateway, right-click the gateway (blue icon) in the **Hardware - Tree** module, and choose the **Reset Gateway** command, as shown in [Figure C-20](#).

**Figure C-20** Reset Gateway Command

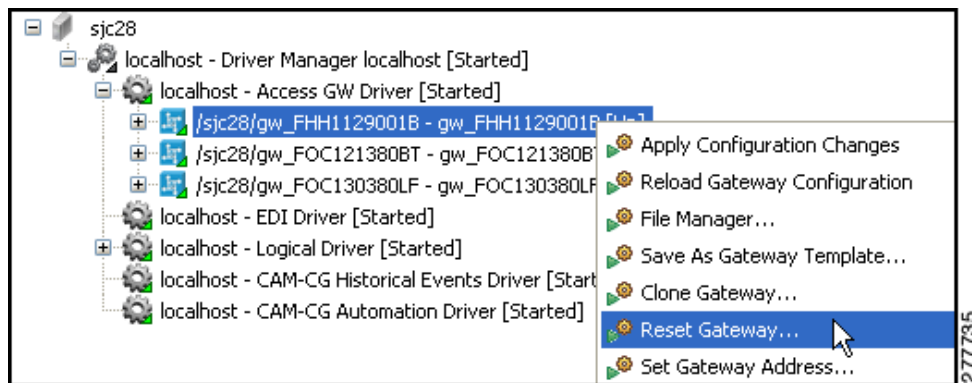

## Gateway Firmware Backward Compatibility

The ICPAM Release 2.1 is backward compatible with the Cisco PAM 1.5.1. Users using earlier versions of Cisco PAM should upgrade to version 1.3.2 and then to 1.5.1. The services that worked with Cisco PAM 1.5.0 continue to work with ICPAM 2.1.

ICPAM version 2.1 is backward compatible with gateways running firmware version 1.5.1 and earlier. Gateways with version 1.5.1 work on ICPAM version 2.1 without upgrading the gateway's firmware. However, gateways running older firmware versions (1.3.2 to 1.4.1) have to be upgraded to 1.5.0 or 1.5.1 before working properly.



**Note**

Starting with ICPAM 2.1, CSV import of 500 records in MSP 1-RU platform and CSV import of 1000 records in OVA platform are recommended.



**Note**

The gateway can be upgraded through web admin in Internet Explorer 8.0 or above only if TLS 1.1 is enabled in the IE browser's settings. To enable TLS 1.1, choose **Tools > Internet Options > Advanced > Security**, uncheck the **Use TLS 1.0** check box, and check the **Use TLS 1.1** check box.



## Security

This appendix includes information used to ensure the security of your ICPAM appliance.

### Contents

- [ICPAM TCP Port Requirements for Firewall Connections, page D-1](#)
- [Disabling the ICPAM TFTP Server, page D-2](#)
- [Related Security Documentation, page D-3](#)

## ICPAM TCP Port Requirements for Firewall Connections

[Table D-1](#) lists the TCP ports used by the ICPAM appliance. ICPAM desktop clients require access to these ports when connecting to an ICPAM appliance that is behind a firewall.

**Table D-1** ICPAM Appliance Ports: Firewall Requirements

| Port     | Description                                                      |
|----------|------------------------------------------------------------------|
| TCP 80   | HTTP for video and redirect to HTTPS                             |
| TCP 443  | HTTPS                                                            |
| TCP 1236 | Communication between the ICPAM Clients and the ICPAM Server     |
| TCP 3306 | MYSQL                                                            |
| TCP 4070 | Default port for EM-100 Controller to ICPAM Server communication |
| TCP 8020 | Default port for Gateway to ICPAM communication                  |
| UDP 69   | TFTP                                                             |

If your system includes Identive EM-100 controllers, see “**Default Services and Ports for the EM-100 Controller**” in the *ICPAM Installation Guide*.

# Disabling the ICPAM TFTP Server

The ICPAM appliance includes a TFTP server that is enabled by default. This TFTP server is used primarily to store firmware images for upgrading controllers, as described in [Upgrading Gateway Firmware Images Using ICPAM, page C-11](#).

To disable the TFTP server, perform the following steps.



## Note

If the TFTP server is disabled, you must upgrade the Gateway firmware using image files stored on an external TFTP server. See [Upgrading Gateway Firmware Images Using ICPAM, page C-11](#) for more information.

- Step 1** Log in to the ICPAM Server Administration utility.  
See [Logging on to the ICPAM Server Administration Utility, page 2-2](#).
- Step 2** Select the **Monitoring** tab and then select **Status**.
- Step 3** Verify that the TFTP Service is **Up**, then click **Stop**, as shown in [Figure D-1](#).
- Step 4** After the confirmation message appears, verify that TFTP Service is **Down**.

*Figure D-1 TFTP Service in “Up” State*

The screenshot shows the 'Connected PAM Server Administration' web interface. The 'Monitoring' tab is selected, and the 'Status' sub-tab is active. Under the 'Server' section, the 'Admin State' is 'Up', highlighted with a red box. A 'Stop' button is visible next to it. Under the 'Services' section, the 'TFTP Service' is 'Up' and the 'Web Service API' is 'Enabled'. A 'Cisco Compatible' logo is visible in the bottom right corner.

| Server                   |              |      |
|--------------------------|--------------|------|
| Admin State:             | Up           | Stop |
| Server Mode:             | Active       |      |
| Version:                 | 2.0.0        |      |
| Serial Number:           | 000C29200881 |      |
| High Availability Audit: | disabled     |      |

| Services        |         |         |
|-----------------|---------|---------|
| TFTP Service    | Up      | Stop    |
| Web Service API | Enabled | Disable |

**Note** After the TFTP Service is **Down**, the button changes to **Start**. Click **Start** to enable the TFTP server.

## Related Security Documentation

Refer to the following documentation for security information related to ICPAM.

- *Red Hat Enterprise Linux 6.4 Security Guide*  
[https://access.redhat.com/site/documentation/en-US/Red\\_Hat\\_Enterprise\\_Linux/6/html/Security\\_Guide/index.html](https://access.redhat.com/site/documentation/en-US/Red_Hat_Enterprise_Linux/6/html/Security_Guide/index.html)
- Security in MySQL  
<http://dev.mysql.com/doc/mysql-security-excerpt/5.5/en/>



## Troubleshooting

If your ICPAM appliance is not working as expected, begin troubleshooting by following the procedures in this appendix. This appendix guides you through some initial checks and procedures that can help you solve some basic problems.

### Contents

- [Licensing: Frequently Asked Questions, page E-1](#)

## Licensing: Frequently Asked Questions

This section provides answers to common licensing questions. For more information, see [“Obtaining and Installing Optional Feature Licenses”](#) section on page 2-45.

*Table E-1 Licensing: Frequently Asked Questions*

| Question                                                      | Answer                                                                                                                                                                           |
|---------------------------------------------------------------|----------------------------------------------------------------------------------------------------------------------------------------------------------------------------------|
| What does the ICPAM base license cover?                       | The base license includes these services and modules: <ul style="list-style-type: none"> <li>• All hardware modules</li> <li>• Web services</li> <li>• Badge Designer</li> </ul> |
| What additional license SKUs are available for added modules? | None. All module licenses are purchases bundled with the hardware. New hardware does not require additional license installation.                                                |

Table E-1 Licensing: Frequently Asked Questions (continued)

| Question                                                                                                           | Answer                                                                                                                                                                                                                                                                                                                                                                                                                                                                                                                                                                                                                                                                                                                                                          |
|--------------------------------------------------------------------------------------------------------------------|-----------------------------------------------------------------------------------------------------------------------------------------------------------------------------------------------------------------------------------------------------------------------------------------------------------------------------------------------------------------------------------------------------------------------------------------------------------------------------------------------------------------------------------------------------------------------------------------------------------------------------------------------------------------------------------------------------------------------------------------------------------------|
| How are licenses keyed to the specific server?                                                                     | <p>By the ICPAM software serial number that is obtained using the ICPAM Server Administration utility. The serial number is 16 hexadecimal digits in the range of 0-F. The server hardware serial number is not used.</p>  <p>The screenshot shows the 'Connected PAM Server Administration' web interface. The 'Serial Number' field is highlighted in green, displaying the value '000C19200881'. Other fields include 'Admin State: Up', 'Server Mode: Active', 'Version: 2.0.0', and 'High Availability Audit: Disabled'. Services listed include 'TFTP Service: Up' and 'Web Service API: Enabled'. A 'Cisco Compatible' logo is visible in the bottom right corner.</p> |
| If the ICPAM is in an HA (high availability) configuration with two servers, do I need two copies of each license? | No, all licenses are installed on the primary server, with the exception of the HA license. The HA license is the only license installed on the standby server.                                                                                                                                                                                                                                                                                                                                                                                                                                                                                                                                                                                                 |
| What is the SKU for the HA feature?                                                                                | CIAC-CPAME-HA= is the SKU for the HA license.                                                                                                                                                                                                                                                                                                                                                                                                                                                                                                                                                                                                                                                                                                                   |
| Can a license be moved to another ICPAM server?                                                                    | No, once a license is issued it is bound to the server serial number that the license is issued against. You must obtain a new license for the server you wish to move the license to.                                                                                                                                                                                                                                                                                                                                                                                                                                                                                                                                                                          |
| Who handles licensing issues for the ICPAM server?                                                                 | Identiv customer support can assist with installing a license but cannot generate licenses. If you have a problem with the license file itself you can email <a href="mailto:licensing@identiv.com">licensing@identiv.com</a> and seek additional assistance. You should include the ICPAM serial number and the purchase or sales order number as well.                                                                                                                                                                                                                                                                                                                                                                                                        |
| What software features require a license?                                                                          | <ul style="list-style-type: none"> <li>• The Enterprise Data Integration (EDI) feature requires SKU CIAC-EDI=</li> <li>• The High Availability (HA) feature requires CIAC-PAME-HA=</li> </ul>                                                                                                                                                                                                                                                                                                                                                                                                                                                                                                                                                                   |
| What software features require a license?                                                                          | The E? A? I? (EAI) feature requires CIAC-PAME-EAI=                                                                                                                                                                                                                                                                                                                                                                                                                                                                                                                                                                                                                                                                                                              |

Table E-1 Licensing: Frequently Asked Questions (continued)

| Question                                                   | Answer                                                                                                                                                                                                                                                                                                                                                                                                                                                                                                                                                                                                            |
|------------------------------------------------------------|-------------------------------------------------------------------------------------------------------------------------------------------------------------------------------------------------------------------------------------------------------------------------------------------------------------------------------------------------------------------------------------------------------------------------------------------------------------------------------------------------------------------------------------------------------------------------------------------------------------------|
| <p>What is the process to acquire additional licenses?</p> | <p>Identiv or our partner generates a sales order and the licensing team then generates a PAK (Product Authorization Key). The PAK is entered into the Identiv.com licensing portal, and a license file is generated. The file can be downloaded at this point. The file is then installed onto the ICPAM primary server (except the HA license which is installed on the standby server) using the Web GUI interface. See the <a href="#">“Obtaining and Installing Optional Feature Licenses”</a> section on page 2-45.</p>  |
| <p>What are controller conversion licenses for?</p>        | <p>These are for supporting non-ICPAM access panels.</p>                                                                                                                                                                                                                                                                                                                                                                                                                                                                                                                                                          |



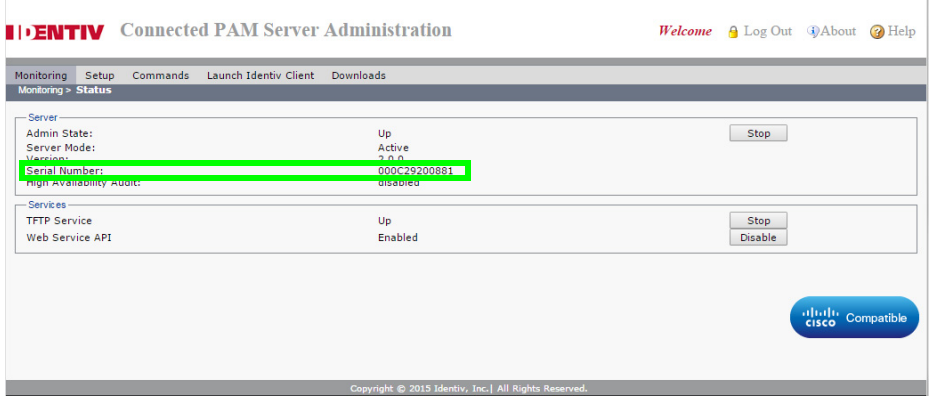
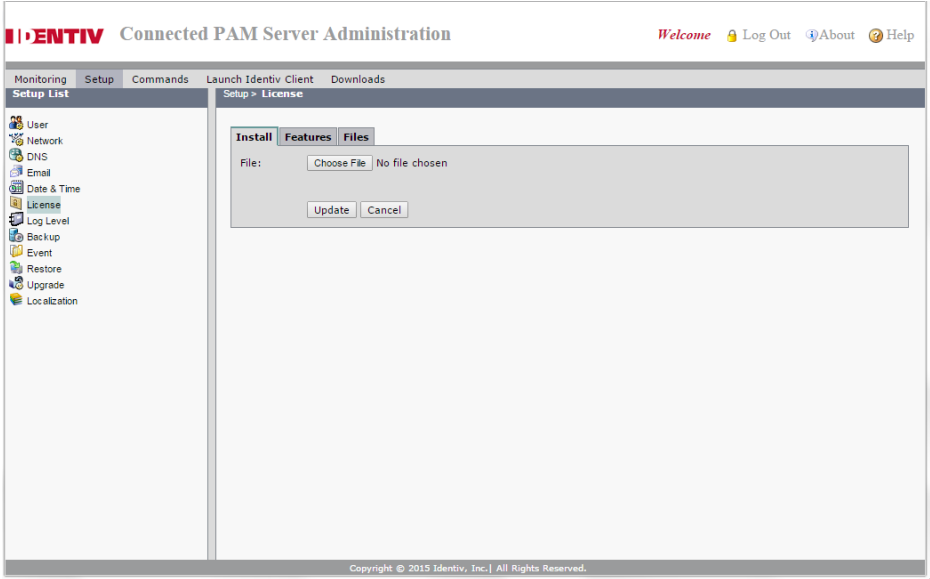

## Related Documentation

---

Refer to the following documentation for additional information and instructions for the features and subjects discussed in this guide:

- [Physical Access Control User Documentation, page F-1](#)
- [Cisco Video Surveillance Manager \(Cisco VSM\) User Documentation, page F-1](#)
- [Cisco IP Interoperability and Collaboration System \(IPICS\) Documentation, page F-2](#)
- [Related Security Documentation, page F-2](#)

### Physical Access Control User Documentation

- [Identiv Connected Access Control API Reference Guide](#)
- [Identiv Connected Physical Access Manager User Guide](#)
- [Identiv Connected Physical Access Manager Quick Start Guide](#)
- [Cisco Physical Access Gateway Quick Start Guide](#)
- [Cisco Physical Access Gateway User Guide](#)
- [Cisco Physical Security Multiservices Platform Series User Guide](#)
- [Release Notes for ICPAM](#)

### Cisco Video Surveillance Manager (Cisco VSM) User Documentation

- [Cisco Video Surveillance Manager User Guide, Release 6.3](#)
- [Installing and Upgrading Cisco Video Surveillance Manager Release 6.3](#)
- [Video Surveillance Monitoring Workstation Recommended Baseline Specification](#)

# Cisco IP Interoperability and Collaboration System (IPICS) Documentation

- [Cisco IPICS Documentation Roadmaps](#)
- [Cisco IPICS API Reference Guide](#)
- [Cisco IPICS End User Guide](#)
- [Cisco IPICS Server Administration Guide](#)
- [Cisco IPICS Documentation \(links to all available technical documentation\)](#)

## Related Security Documentation

Refer to the following documentation for security information related to ICPAM.

- *Red Hat Enterprise Linux 6.4 Security Guide*  
[https://access.redhat.com/site/documentation/en-US/Red\\_Hat\\_Enterprise\\_Linux/6/html/Security\\_Guide/index.html](https://access.redhat.com/site/documentation/en-US/Red_Hat_Enterprise_Linux/6/html/Security_Guide/index.html)
- Security in MySQL  
<http://dev.mysql.com/doc/mysql-security-excerpt/5.5/en/>



---

## A

- access point** An access-controlled point of entry such as a door, turnstile, or gate. At the hardware level, this consists of a grouping of devices, such as:
- Door Contact
  - Door Strike
  - Reader
  - REX button
- access policy** A set of access points, each with a corresponding time schedule, that determine where and when a badge holder has permission to pass through an access point.
- See also:* access point
- ADA** The acronym for the Americans with Disabilities Act. ICPAM enables you to program a door so that when a disabled person presents a special category of badge (or enters a special category of PIN code), the door provides additional time to accommodate their particular needs.
- ADA strike time** The time before the door strike locks a door after access has been granted, for badge holders who need more time entering and exiting access points (due to a physical disability).
- alarm** An event that has been configured to be presented as an alarm to the operator. Alarms may be in different states indicated by color and/or blinking, and alarms may be acknowledged, cleared, and commented on by the operator. An alarm has an associated priority which indicates its severity or importance.
- See also:* event
- alarm state** The state of an alarm, based on operator actions. May be one of several states which also have an associated color and/or blinking:
- *Active:* Blinking red. The alarm is new and has not been acknowledged or resolved in any way.
  - *Acknowledged:* Solid orange. An operator is aware of the alarm, but it has not been resolved.
  - *Cleared:* Solid green. The alarm has been resolved.
- See also:* alarm, top alarm state
- APB** *See:* anti-passback

|                                  |                                                                                                                                                                                                                                                                                                                                                                                                                                                                                                                                                                                                                                                                                                                                                                                                                                                                      |
|----------------------------------|----------------------------------------------------------------------------------------------------------------------------------------------------------------------------------------------------------------------------------------------------------------------------------------------------------------------------------------------------------------------------------------------------------------------------------------------------------------------------------------------------------------------------------------------------------------------------------------------------------------------------------------------------------------------------------------------------------------------------------------------------------------------------------------------------------------------------------------------------------------------|
| <b>anti-passback</b>             | A mode of operation that hinders a badge holder from entering an access point, then passing back their badge to another person to enter the same area. The consequences of violating the anti-passback conditions vary depending on the mode of anti-passback the individual access point is configured for.<br><br><i>See also:</i> area                                                                                                                                                                                                                                                                                                                                                                                                                                                                                                                            |
| <b>anti-passback (APB) delay</b> | The time a badge holder must wait before they can reuse their badge at the same reader. This is not used for all APB modes.<br><br><i>See also:</i> anti-passback, anti-passback mode                                                                                                                                                                                                                                                                                                                                                                                                                                                                                                                                                                                                                                                                                |
| <b>anti-passback (APB) mode</b>  | A mode which determines how anti-passback is enforced. The following is a list of possible modes. <ul style="list-style-type: none"> <li>• <b>Soft (grant access):</b> Will let the badge use the reader if the badge has an incorrect entry area, but reports the passback violation to the software.</li> <li>• <b>Hard (deny access):</b> Will not let the badge use the reader if the badge has an incorrect entry area.</li> <li>• <b>Reader-based using reader history:</b> Same badge cannot be used twice in a row at this reader within the delay time.</li> <li>• <b>Reader-based using card history:</b> The badge cannot be used two consecutive times at this reader within the delay time, even if others use the reader.</li> <li>• <b>Area-based:</b> Hard APB within delay, soft APB after delay time.</li> </ul><br><i>See also:</i> anti-passback |
| <b>area</b>                      | When an access point is configured for APB, the access point has an associated entry area and exit area. These areas are used to track the badge holders location.<br><br><i>See also:</i> anti-passback                                                                                                                                                                                                                                                                                                                                                                                                                                                                                                                                                                                                                                                             |
| <b>audit record</b>              | A record of an operator modifying an object in the system, including the date, time, and the state of the object before and after the edit. An audit record is a type of event.<br><br><i>See also:</i> event                                                                                                                                                                                                                                                                                                                                                                                                                                                                                                                                                                                                                                                        |

---

## B

|                  |                                                                                                                                                                                                                                   |
|------------------|-----------------------------------------------------------------------------------------------------------------------------------------------------------------------------------------------------------------------------------|
| <b>badge</b>     | Also known as a card. A type of credential encoded with a card number, generally on a magnetic stripe or internally like a proximity card, and used to enter access points.                                                       |
| <b>baud rate</b> | A measure of the rate at which a modem or serial connection transmits data. This is measured in bits per second (bps).                                                                                                            |
| <b>biometric</b> | Biometric verification is any means by which a person can be uniquely identified by evaluating one or more distinguishing biological traits. A biometric in ICPAM refers to a type of credential used for biometric verification. |

---

**C**

|                                          |                                                                                                                                                                                                                                                                                                                                                                                                                                                                                                                                                                                                                                                                                                                                                                                                                                 |
|------------------------------------------|---------------------------------------------------------------------------------------------------------------------------------------------------------------------------------------------------------------------------------------------------------------------------------------------------------------------------------------------------------------------------------------------------------------------------------------------------------------------------------------------------------------------------------------------------------------------------------------------------------------------------------------------------------------------------------------------------------------------------------------------------------------------------------------------------------------------------------|
| <b>calendar</b>                          | A calendar defines a set of holidays. The holidays within the calendars are then used in conjunction with access policies to control access during holiday periods.                                                                                                                                                                                                                                                                                                                                                                                                                                                                                                                                                                                                                                                             |
| <b>camera</b>                            | Cameras record digital video files to be stored on the DVR.<br><br><i>See also:</i> closed circuit television                                                                                                                                                                                                                                                                                                                                                                                                                                                                                                                                                                                                                                                                                                                   |
| <b>CAN (Controller Area Network) bus</b> | A 3-wire parallel communication bus that runs between the Gateway and up to a total of 15 additional modules. These additional modules can be any combination of Reader, Input, or Output modules.<br><br>The distance limit on the CAN bus is 1320 feet. The last module on the CAN bus must be set to terminate the CAN bus.                                                                                                                                                                                                                                                                                                                                                                                                                                                                                                  |
| <b>card</b>                              | <i>See</i> badge.                                                                                                                                                                                                                                                                                                                                                                                                                                                                                                                                                                                                                                                                                                                                                                                                               |
| <b>card format</b>                       | The bit structure of a particular card. The typical card format includes the card number, facility code, and parity bits. The two types of card formats supported by ICPAM are Wiegand and magstripe.                                                                                                                                                                                                                                                                                                                                                                                                                                                                                                                                                                                                                           |
| <b>card format type</b>                  | The type of a card format, which may be Wiegand or magstripe.<br><br><i>See also:</i> Wiegand, magnetic stripe                                                                                                                                                                                                                                                                                                                                                                                                                                                                                                                                                                                                                                                                                                                  |
| <b>card number</b>                       | The card number encoded within the badge, often on the magnetic stripe or internally for proximity cards.<br><br><i>See also:</i> badge                                                                                                                                                                                                                                                                                                                                                                                                                                                                                                                                                                                                                                                                                         |
| <b>CCTV</b>                              | The acronym for Closed Circuit Television.                                                                                                                                                                                                                                                                                                                                                                                                                                                                                                                                                                                                                                                                                                                                                                                      |
| <b>CHUID/CUID</b>                        | Card Holder Unique Identity model.                                                                                                                                                                                                                                                                                                                                                                                                                                                                                                                                                                                                                                                                                                                                                                                              |
| <b>closed circuit television</b>         | A collection of surveillance cameras conducting video surveillance. Each camera is viewable on a monitor.                                                                                                                                                                                                                                                                                                                                                                                                                                                                                                                                                                                                                                                                                                                       |
| <b>controller</b>                        | A device that can accept one 10-wire Wiegand reader, or two 5-wire Wiegand readers, three inputs, three outputs, power fail, and tamper sensor inputs. The gateway communicates with the ICPAM server over TCP/IP via Ethernet. It also communicates up to 15 additional reader, input, or output modules over a 3-wire CAN bus. The gateway can be powered using either PoE or 12V or 24V DC.<br><br>The controller can download badge access credentials and store them locally permitting access control even without network connectivity to the ICPAM server. Events that occur while the connection to the server is down are stored locally and uploaded to the ICPAM server once the network connection resumes.<br><br>Two types of controllers are supported by ICPAM: Cisco Gateways and Identiv EM-100 controllers. |
| <b>credential</b>                        | A general category that includes login, badge, and biometric; something that is used to gain access to a physical or logical resource.<br><br><i>See also:</i> badge, biometric, login                                                                                                                                                                                                                                                                                                                                                                                                                                                                                                                                                                                                                                          |

---

**D**

|                                |                                                                                                                                                                                                                                                                                                                                                                                                                                                                                                                                                                                          |
|--------------------------------|------------------------------------------------------------------------------------------------------------------------------------------------------------------------------------------------------------------------------------------------------------------------------------------------------------------------------------------------------------------------------------------------------------------------------------------------------------------------------------------------------------------------------------------------------------------------------------------|
| <b>dashboard</b>               | A module with real-time graphs, charts, and diagrams that is used for monitoring details and statistics for the system.                                                                                                                                                                                                                                                                                                                                                                                                                                                                  |
| <b>debounce</b>                | <p>Debounce is a parameter representing the number of consecutive scans that must be in agreement before changing the state of the input point. Debounce is used to prevent incorrect reads. Each scan period is 16.7 milliseconds. The recommended setting is 2 ms for a REX, and 4-6 ms for standard inputs.</p> <p><i>See also:</i> input point</p>                                                                                                                                                                                                                                   |
| <b>Dedicated Micros driver</b> | <p>The Dedicated Micros driver is a software device that manages the sending and receiving of data between the CCTV cameras and the DVR.</p> <p><i>See also:</i> driver</p>                                                                                                                                                                                                                                                                                                                                                                                                              |
| <b>default Gateway</b>         | <p>In a network using subnets, the router that forwards traffic to a destination outside of the subnet of the transmitting device.</p> <p><i>See also:</i> subnet</p>                                                                                                                                                                                                                                                                                                                                                                                                                    |
| <b>department</b>              | <p>A sub-division of an organization, which is used to organize personnel.</p> <p><i>See also:</i> organization</p>                                                                                                                                                                                                                                                                                                                                                                                                                                                                      |
| <b>device</b>                  | A hardware (and in some cases software) component in the system. Events are generally associated with a device. Devices also can have different states with varying color and severity.                                                                                                                                                                                                                                                                                                                                                                                                  |
| <b>device status</b>           | <p>The real-time status of a device. Examples include: Online, Offline, Unknown, Secure, and Alarm. Each state has an associated color and severity. Not to be confused with top alarm state, which depends on operator actions in the application. For example, if a door is forced open, and then shut again, the status will go from forced open to secure, but the top alarm state will reflect the forced open state until an operator clears it.</p> <p><i>See also:</i> top alarm state</p>                                                                                       |
| <b>device status module</b>    | Allows operators to monitor the real-time status of all devices connected within the access-control. Operators can view the device properties, as well as status and the top alarm at any given device.                                                                                                                                                                                                                                                                                                                                                                                  |
| <b>DHCP</b>                    | <p>Dynamic Host Configuration Protocol (DHCP). A network application that automatically assigns IP addresses to devices in the network.</p> <p>The Cisco Physical Access Gateway can obtain an IP address via DHCP. DHCP options 150 and 151 can also be passed with the DHCP lease. These options point the controller to the ICPAM Server and TCP port to use for the Gateway to ICPAM server TCP/IP session. The Gateway can also have a static IP address. The ICPAM server should have a static IP address. The Reader, Input, and Output modules do not require an IP address.</p> |
| <b>DIP switch</b>              | A set of small on-off switches mounted on hardware. The DIP switches are used to configure settings on the hardware.                                                                                                                                                                                                                                                                                                                                                                                                                                                                     |

|                       |                                                                                                                                                                                                                                                                                                                                                                                                                                                                                                                                                                                                                                                                                                                                                                                                                                                                                                                                                                             |
|-----------------------|-----------------------------------------------------------------------------------------------------------------------------------------------------------------------------------------------------------------------------------------------------------------------------------------------------------------------------------------------------------------------------------------------------------------------------------------------------------------------------------------------------------------------------------------------------------------------------------------------------------------------------------------------------------------------------------------------------------------------------------------------------------------------------------------------------------------------------------------------------------------------------------------------------------------------------------------------------------------------------|
| <b>door contact</b>   | <p>A door contact is a device that monitors whether a door is open or closed. A door contact is part of an access point.</p> <p><i>See also:</i> access point</p>                                                                                                                                                                                                                                                                                                                                                                                                                                                                                                                                                                                                                                                                                                                                                                                                           |
| <b>door strike</b>    | <p>A door strike is a device that physically locks or unlocks the door. A door strike is part of an access point.</p> <p><i>See also:</i> access point</p>                                                                                                                                                                                                                                                                                                                                                                                                                                                                                                                                                                                                                                                                                                                                                                                                                  |
| <b>driver</b>         | <p>A process on a host computer used to communicate between the host computer and hardware devices. Different types of supported hardware generally have different drivers.</p>                                                                                                                                                                                                                                                                                                                                                                                                                                                                                                                                                                                                                                                                                                                                                                                             |
| <b>driver manager</b> | <p>A driver manager is a software device that manages all drivers in the system.</p> <p><i>See also:</i> driver</p>                                                                                                                                                                                                                                                                                                                                                                                                                                                                                                                                                                                                                                                                                                                                                                                                                                                         |
| <b>duress request</b> | <p>This is a feature used by a badge holder under duress on a reader/keypad configured to accept PIN and Duress entries. If the badge holder enters their assigned PIN plus the configured duress key or keys, this will send a duress signal to the access-control system.</p> <p>For example: Duress code is configured as 1 digit, and that is 5. An individual has a personal identification number of 1111. If that individual enters 1110 or 1111, no duress indication is sent to the access-control system. If the individual enters 1115, a duress indication will be sent to the access-control system.</p> <p>In this example, any PIN entry of 1111x, where x is 0 through 4 or 6 though 9 will result in grant access with no duress signal. Only a PIN entry of 1115 will grant access with a duress signal. If the user enters 1111 only, the PIN entry time-out will have to expire before the individual will be granted access with no duress signal.</p> |
| <b>DVR</b>            | <p>DVR is the acronym for digital video recorder. A DVR records video from CCTV cameras to disk. This enables the viewing of live or past video.</p> <p><i>See also:</i> CCTV</p>                                                                                                                                                                                                                                                                                                                                                                                                                                                                                                                                                                                                                                                                                                                                                                                           |

---

## E

|                   |                                                                                                                                                                                                                                                                                                                                                                                                                                                           |
|-------------------|-----------------------------------------------------------------------------------------------------------------------------------------------------------------------------------------------------------------------------------------------------------------------------------------------------------------------------------------------------------------------------------------------------------------------------------------------------------|
| <b>EDI</b>        | <p>The acronym for Electronic Data Interchange, which is the transfer of data from one computer system to another by standardized message formatting without the need for human intervention. EDI permits multiple companies -- possibly in different countries -- to exchange documents electronically. Data can be exchanged through serial links and peer-to-peer networks, though most exchanges currently rely on the Internet for connectivity.</p> |
| <b>encryption</b> | <p>A method of securing data so it cannot be read by unauthorized users or applications. ICPAM's configuration file and card database located on the controller are encrypted.</p> <p>ICPAM backup files created by the back up process are encrypted with a password. The password used when creating the backup file must be entered when using the file for a restore operation.</p>                                                                   |

|                             |                                                                                                                                                                                                                                                                                                                                                                                                                                                                                                                                                                                   |
|-----------------------------|-----------------------------------------------------------------------------------------------------------------------------------------------------------------------------------------------------------------------------------------------------------------------------------------------------------------------------------------------------------------------------------------------------------------------------------------------------------------------------------------------------------------------------------------------------------------------------------|
| <b>event</b>                | An activity within the system, recorded to the database, and available for monitoring or reporting.                                                                                                                                                                                                                                                                                                                                                                                                                                                                               |
| <b>Event Policy Manager</b> | <p>A module used to configure the way events are processed and displayed. This following attributes can be configured:</p> <ul style="list-style-type: none"><li>• <b>Is alarm:</b> This determines whether the event is an event or alarm.</li><li>• <b>Is recorded:</b> This determines whether the event is recorded. If the event is not recorded, it can not be an alarm.</li><li>• <b>Priority:</b> This determines the priority of the event or alarm.</li><li>• <b>Alert sound:</b> The sound to be played when the event occurs.</li></ul> <p><i>See also:</i> event</p> |

---

## F

|                         |                                                                                                                                                                             |
|-------------------------|-----------------------------------------------------------------------------------------------------------------------------------------------------------------------------|
| <b>facility code</b>    | A segment of bits encoded on a card which represent a number in association with a facility. Often all cards issued for a single facility will have the same facility code. |
| <b>fail-safe lock</b>   | A lock that requires voltage to remain in the locked state. If voltage is removed, the lock will move to the unlocked state.                                                |
| <b>fail secure lock</b> | A lock that does not require voltage to remain in the locked state. If voltage is removed, the lock remains in the locked state.                                            |
| <b>FASC-N</b>           | The acronym for Federal Agency Smart Card Number.                                                                                                                           |
| <b>filter</b>           | A tool allowing operators to select which objects should be displayed.                                                                                                      |
| <b>FIN</b>              | Foreign Identification Number. Used as an alternative to the Social Security Number (SSN) issued to American citizens.                                                      |

---

## G

|                            |                                                                                                                                                                                                                                                                                                          |
|----------------------------|----------------------------------------------------------------------------------------------------------------------------------------------------------------------------------------------------------------------------------------------------------------------------------------------------------|
| <b>GND pins</b>            | Ground for the DC voltage input.                                                                                                                                                                                                                                                                         |
| <b>Graphic Maps Editor</b> | A module which allows graphic maps to be imported and configured. A graphic map can have links to other maps and or links to other devices. The map links can be used to navigate between maps in the Graphic Maps Viewer. The device links show the real-time status of the device in the graphic maps. |
| <b>Graphic Maps Viewer</b> | A module allowing facility maps to be viewed. The Graphic Maps Viewer displays the location and status of devices within the facility. The maps can also contain links used to navigate to other maps.                                                                                                   |



---

## H

|                        |                                                                                                                                                                                                                                                                                                                                                     |
|------------------------|-----------------------------------------------------------------------------------------------------------------------------------------------------------------------------------------------------------------------------------------------------------------------------------------------------------------------------------------------------|
| <b>HA</b>              | The acronym for High Availability. In the event of physical server failure, affected virtual machines are automatically restarted on other production servers with spare capacity. (In the case of operating system failure, VMware HA restarts the affected virtual machine on the same physical server.)                                          |
| <b>hardware</b>        | <i>See:</i> device                                                                                                                                                                                                                                                                                                                                  |
| <b>hardware module</b> | A module allowing operators to add, edit, and disable the hardware.<br><br><i>See also:</i> device                                                                                                                                                                                                                                                  |
| <b>hardware tree</b>   | The hardware tree is a hierarchical display of all devices in the system, seen in the Hardware - Tree module and the graphics. Each device in the hardware tree can be expanded or collapsed to show or hide its sub-devices by clicking the + or - to its left.<br><br><i>See also:</i> device, hardware module, hardware tree                     |
| <b>hexadecimal</b>     | A base-16 numbering system written using the symbols 0–9 and A–F (or a–f).                                                                                                                                                                                                                                                                          |
| <b>HID</b>             | A company manufacturing the industry-standard proximity access-control cards.<br><br><i>See also:</i> proximity                                                                                                                                                                                                                                     |
| <b>hold time</b>       | The amount of time in seconds that the system will ignore an active state of a monitor point. The system will hold a higher priority status before a lower priority status is reported. As an example, motion detectors can sometimes trigger multiple times per second, which could cause the Event logs to quickly fill up with unnecessary data. |
| <b>hot stamp</b>       | The number physically printed or embossed on a badge. This number is generally independent of the Card Number. Not all badges have a hot stamp number.<br><br><i>See also:</i> badge                                                                                                                                                                |
| <b>HSPD-12</b>         | The acronym for Homeland Security Presidential Directive 12, which is a policy for a common identification standard for federal employees and contractors.                                                                                                                                                                                          |
| <b>HTTPS</b>           | Hypertext Transfer Protocol Secure. A combination of the Hypertext Transfer Protocol and a network security protocol. Gateway and ICPAM HTTP access is via HTTPS.<br><br><i>See also:</i> <a href="#">SSL</a> .                                                                                                                                     |

---

## I

|                     |                                                                                                                                                                                                                                                                                                                                                                    |
|---------------------|--------------------------------------------------------------------------------------------------------------------------------------------------------------------------------------------------------------------------------------------------------------------------------------------------------------------------------------------------------------------|
| <b>ICPAM client</b> | A Java applet running on a Windows client PC or workstation that is used to manage the ICPAM server and associated Gateways. It can be used to monitor the physical access system of sensors and locks. It can be used to configure the operation of the ICPAM server and the access modules.                                                                      |
| <b>ICPAM server</b> | An appliance used to manager and monitor a physical access infrastructure comprised of door controller, reader, input, and output modules. It can interact with corporate directories like LDAP or MS Active Directory to validate access credentials for user access badges. It also interacts with Cisco VSM to provide video for configured devices and events. |

|                     |                                                                                                                                                                                                                                                                                                                                                                                                                                                                                                                                                                   |
|---------------------|-------------------------------------------------------------------------------------------------------------------------------------------------------------------------------------------------------------------------------------------------------------------------------------------------------------------------------------------------------------------------------------------------------------------------------------------------------------------------------------------------------------------------------------------------------------------|
| <b>input</b>        | <p>A sensor that has 2 states, open or closed. The steady state can either be normally open (NO) or normally closed (NC). When moved to the non-steady state, the input is used to make a decision. Typical input is a door sensor. It is used to determine if the door is in the opened or closed position. An input has 2 pins marked + and -. Gateway, Reader, and Input module inputs can be supervised or un-supervised. See also <a href="#">supervised input</a>.</p> <p>Inputs do not require separate power, because it is supplied from the module.</p> |
| <b>Input module</b> | A device that can accept 10 inputs. It communicates with the ICPAM server via the CAN bus and the controller. The module requires an external 12V to 24V DC source and cannot be powered via POE.                                                                                                                                                                                                                                                                                                                                                                 |
| <b>IP address</b>   | The Internet Protocol address. The gateway can obtain an IP address via DHCP. DHCP options 150 and 151 can also be passed with the DHCP lease. These options point the controller to the ICPAM server and TCP port to use for the gateway to ICPAM server TCP/IP session. The Gateway can also have a static IP address. The ICPAM server should have a static IP address. The Reader, Input, and Output modules do not require an IP address.                                                                                                                    |

---

## L

|                      |                                                                                                                                                                                                                                                        |
|----------------------|--------------------------------------------------------------------------------------------------------------------------------------------------------------------------------------------------------------------------------------------------------|
| <b>LDAP</b>          | The acronym for Lightweight Directory Access Protocol, which is a networking protocol for querying and modifying directory services running over TCP/IP.                                                                                               |
| <b>LED</b>           | Light-emitting diode. A semiconductor diode that converts applied voltage to light. LEDs are used to display status, communication, and other information on various devices.                                                                          |
| <b>Localhost</b>     | The default hostname describing the local computer's address.                                                                                                                                                                                          |
| <b>login</b>         | <p>A credential used to obtain access to the application as an operator. A login has a username and password, along with a set of profiles which determine what the operator has access to within the application.</p> <p><i>See also:</i> profile</p> |
| <b>Logins module</b> | <p>A module used to manage operator logins in the application.</p> <p><i>See also:</i> login</p>                                                                                                                                                       |

---

## M

|                        |                                                                                                                                                               |
|------------------------|---------------------------------------------------------------------------------------------------------------------------------------------------------------|
| <b>MAC address</b>     | The acronym for Media Access Control address, which uniquely identifies each node of a network. Each type of network medium requires a different MAC address. |
| <b>magnetic stripe</b> | <p>A strip of magnetic recording material on which a certain data is stored.</p> <p><i>See also:</i> card format type, Wiegand</p>                            |
| <b>masked</b>          | A hardware state for monitor points and access points where one or more active conditions will be reported to the software as masked.                         |
| <b>module</b>          | An independent section of ICPAM with some distinct function.                                                                                                  |

|                            |                                                                                                                                                                                                                                                                                               |
|----------------------------|-----------------------------------------------------------------------------------------------------------------------------------------------------------------------------------------------------------------------------------------------------------------------------------------------|
| <b>monitor point</b>       | A monitor point is an input on a sub-controller that is configured to monitor an external device or signal, typically an alarm input.                                                                                                                                                         |
| <b>monitor point group</b> | A monitor point group is an operator defined organization of access points and monitor points. Commands issued to the MPG influence all of the contained devices. A total of 128 monitor points or 64 access points can be included in a MPG. One access point counts for two monitor points. |
| <b>multiplexer</b>         | A type of hardware which can combine multiple communication channels into a single communications channel.                                                                                                                                                                                    |

---

## O

|                      |                                                                                                                                                                                                                                                                                                                                                                                                                                                                                                                                                                                                                                                                                                                                                                                                                                                                                                                                                                                               |
|----------------------|-----------------------------------------------------------------------------------------------------------------------------------------------------------------------------------------------------------------------------------------------------------------------------------------------------------------------------------------------------------------------------------------------------------------------------------------------------------------------------------------------------------------------------------------------------------------------------------------------------------------------------------------------------------------------------------------------------------------------------------------------------------------------------------------------------------------------------------------------------------------------------------------------------------------------------------------------------------------------------------------------|
| <b>output</b>        | <p>A device that requires a trigger to change state. The steady state is either normally open (NO) or normally closed (NC). After a decision is made for the device to change state, the module output interface will open or close a relay to trigger the device. A typical output device is an electric-mechanical door lock. For example: When not triggered, the lock is in the 'locked' position. When triggered by the output module, the lock moves to the 'unlocked' position.</p> <p>Outputs generally require power, and the output module will either close or open a relay to trigger the device. The power to drive the device should be inline with the relay on the output module. The output relay on the module has 3 pins marked NC, C, and NO. NC is normally closed, C is common or ground, and NO is normally open. An exception might be for a POE-capable lock, where the power for the lock is obtained from the Reader attachment of a Gateway or reader module.</p> |
| <b>output module</b> | A device that can drive 8 outputs. It communicates with the ICPAM server via the CAN bus and the controller. The module requires an external 12V to 24V DC source and cannot be powered via POE.                                                                                                                                                                                                                                                                                                                                                                                                                                                                                                                                                                                                                                                                                                                                                                                              |
| <b>organization</b>  | An organization with which a personnel record can be associated.                                                                                                                                                                                                                                                                                                                                                                                                                                                                                                                                                                                                                                                                                                                                                                                                                                                                                                                              |

---

## P

|                            |                                                                                                                                                                                                                                                                                                             |
|----------------------------|-------------------------------------------------------------------------------------------------------------------------------------------------------------------------------------------------------------------------------------------------------------------------------------------------------------|
| <b>PDF</b>                 | The acronym for Adobe's Portable Document Format, which represents a printable/viewable document in a manner that is independent of the original system used to create it. Viewing PDF documents requires the Adobe Reader, which is freely available at <a href="http://www.adobe.com">www.adobe.com</a> . |
| <b>personnel module</b>    | A module used to manage personnel information.                                                                                                                                                                                                                                                              |
| <b>PF input</b>            | This input is used to detect a power failure. If activated, an alarm is posted notifying the administrators that a device has lost power. The PF input has 2 pins marked + and -. This input can be re-allocated to act as an unsupervised input.                                                           |
| <b>PIN</b>                 | Personal Identification Number. A badge has a PIN associated with it, which, depending on the configuration of an access point, is entered into the keypad on the access point's reader.                                                                                                                    |
| <b>POE</b>                 | The acronym for Power Over Ethernet, which provides up to 15.4 watts to power devices attached via a CAT5 cable to a POE-capable switch.                                                                                                                                                                    |
| <b>Power Over Ethernet</b> | <i>See:</i> <a href="#">POE</a> .                                                                                                                                                                                                                                                                           |

|                        |                                                                                                                                                                            |
|------------------------|----------------------------------------------------------------------------------------------------------------------------------------------------------------------------|
| <b>privilege</b>       | Privileges define what a credential has access to. Examples of privileges include access policies and profiles.<br><br><i>See also:</i> access policy, credential, profile |
| <b>profile</b>         | A profile determines the software modules and the commands that an operator has access to upon logging in.                                                                 |
| <b>Profiles module</b> | A module for managing profiles.<br><br><i>See also:</i> profile                                                                                                            |
| <b>proximity</b>       | A technology where the presence of a certain object can be sensed by a device without having direct contact.<br><br><i>See also:</i> HID                                   |

---

## R

|                      |                                                                                                                                                                                                                                                                                                                                                                                                                                                                                                                                  |
|----------------------|----------------------------------------------------------------------------------------------------------------------------------------------------------------------------------------------------------------------------------------------------------------------------------------------------------------------------------------------------------------------------------------------------------------------------------------------------------------------------------------------------------------------------------|
| <b>reader</b>        | A reader is a device for receiving a card number and/or PIN from a badge holder.                                                                                                                                                                                                                                                                                                                                                                                                                                                 |
| <b>Reader module</b> | A device that can accept one 10-wire Wiegand reader, or two 5-wire Wiegand readers, three inputs, three outputs, power fail, and tamper sensor inputs. It requires a controller to facilitate communication with an ICPAM server. The module requires an external 12V to 24V DC source and cannot be powered via POE.                                                                                                                                                                                                            |
| <b>relay</b>         | A device that responds to a small current or voltage change by activating switches or other devices in an electric circuit.                                                                                                                                                                                                                                                                                                                                                                                                      |
| <b>REX device</b>    | REX is an abbreviation for “request to exit”. A REX device is a type of door hardware, typically a button that allows people to exit through an access point without using a badge. When a door state changes from closed to open, it means someone has unlocked the door from the secure side. If the door state moves from closed to open, with no valid reader swipe or REX activation, it can indicate that the door was forced open. A REX is part of an access point.<br><br><i>See also:</i> <a href="#">access point</a> |
| <b>RTS mode</b>      | A method of hardware flow control used in serial communications.                                                                                                                                                                                                                                                                                                                                                                                                                                                                 |

---

## S

|                              |                                                                                                                                                                                                                                            |
|------------------------------|--------------------------------------------------------------------------------------------------------------------------------------------------------------------------------------------------------------------------------------------|
| <b>Scroll lock</b>           | A tool button in some modules that allows the operator to stop the scrolling of items in the window. New items will continue to be added to the window, but the window will not automatically scroll to show the most recently added item. |
| <b>serial communications</b> | A method of communicating over a dedicated line.                                                                                                                                                                                           |

|                         |                                                                                                                                                                                                                                                                                                                                                                                                                                                                                                                                                                                                                                                                                                                                                                                                                                                                                                                                                                                                                                                                                          |
|-------------------------|------------------------------------------------------------------------------------------------------------------------------------------------------------------------------------------------------------------------------------------------------------------------------------------------------------------------------------------------------------------------------------------------------------------------------------------------------------------------------------------------------------------------------------------------------------------------------------------------------------------------------------------------------------------------------------------------------------------------------------------------------------------------------------------------------------------------------------------------------------------------------------------------------------------------------------------------------------------------------------------------------------------------------------------------------------------------------------------|
| <b>site</b>             | A site is a single instance of an ICPAM database. It generally, but does not necessarily, correspond with a single geographical location, such as a building complex, building, or part of a building. Most installations of ICPAM only have a single database, and hence a single site. Multiple sites are used in larger configurations, for example a company with offices around the world, with an ICPAM database at each office.                                                                                                                                                                                                                                                                                                                                                                                                                                                                                                                                                                                                                                                   |
| <b>SSN</b>              | The acronym for Social Security Number, which is a nine-digit number issued to individuals by the U.S. government for tax purposes, and is often used as an identification number.                                                                                                                                                                                                                                                                                                                                                                                                                                                                                                                                                                                                                                                                                                                                                                                                                                                                                                       |
| <b>SSL</b>              | Secure Sockets Layer. A security protocol for secure connections using over the Internet. Gateway to ICPAM server can utilize SSL for the connection. All gateways and ICPAM server must be configured similarly either for SSL, or for no SSL. A mix of SSL and non-SSL is not supported.<br><br>Gateway and ICPAM HTTP access is via HTTPS.<br><br><i>See also:</i> <a href="#">HTTPS</a> .                                                                                                                                                                                                                                                                                                                                                                                                                                                                                                                                                                                                                                                                                            |
| <b>status</b>           | <i>See:</i> device status                                                                                                                                                                                                                                                                                                                                                                                                                                                                                                                                                                                                                                                                                                                                                                                                                                                                                                                                                                                                                                                                |
| <b>subnet</b>           | A portion of a network, which shares a common network address with other portions of the network and is distinguished by a subnet number. On TCP/IP networks, subnets are defined as all devices whose IP addresses have the same prefix. For example, all devices with IP addresses that start with 100.100.100 would be part of the same subnet.                                                                                                                                                                                                                                                                                                                                                                                                                                                                                                                                                                                                                                                                                                                                       |
| <b>supervised input</b> | A supervised input has 4 states. (1) Short (2) Open (3) Non-Alarm or (4) Alarm.<br><br>An unsupervised input has 2 states. (1) Normal or (2) Alarm.<br><br>Unsupervised inputs have limited functionality. If a wire is cut or shorted between the input module and a normally open device, the server cannot determine the change and the device would remain in inactive state even when the switch is closed.<br><br>To make the input device supervised, use two 1K resistors in the circuit. <ul style="list-style-type: none"> <li>• In the <i>inactive</i> state, the circuit measures 2000 ohms.</li> <li>• In the <i>active</i> state, the circuit measures 1000 ohms.</li> <li>• In the <i>short</i> state, the circuit measures 0 ohms</li> <li>• In the <i>open</i> state, the circuit measures infinite ohms.</li> </ul><br>After the input device is supervised, ICPAM can determine if a wire is cut or shorted.<br><br><i>See also:</i> <a href="#">input</a> , <a href="#">Input module</a> . See <a href="#">Device Configuration Properties</a> for more information. |

---

## T

|                              |                                                                                                                                                          |
|------------------------------|----------------------------------------------------------------------------------------------------------------------------------------------------------|
| <b>TCP/IP communications</b> | A protocol for communication between computers, used as a standard for transmitting data over networks and as the basis for standard Internet protocols. |
| <b>Telnet</b>                | An Internet communications protocol that enables a computer to function as a terminal working from a remote computer.                                    |

|                        |                                                                                                                                                                                                                                                                                                                                                                                                                                                                                                                                     |
|------------------------|-------------------------------------------------------------------------------------------------------------------------------------------------------------------------------------------------------------------------------------------------------------------------------------------------------------------------------------------------------------------------------------------------------------------------------------------------------------------------------------------------------------------------------------|
| <b>time interval</b>   | A period of time defined using a start time and time. Each period has a list of days of the week (Sunday through Saturday) and holidays of when it can be active.                                                                                                                                                                                                                                                                                                                                                                   |
| <b>time received</b>   | The time an event or alarm was actually received by the access-control system and stored in the database.                                                                                                                                                                                                                                                                                                                                                                                                                           |
| <b>time schedule</b>   | A defined set of time intervals used to make access-control, triggering, and other decisions.<br><i>See also:</i> time interval                                                                                                                                                                                                                                                                                                                                                                                                     |
| <b>time zone</b>       | 24 longitudinal divisions of the globe, nominally 15 degrees wide, in which clocks show the same time.                                                                                                                                                                                                                                                                                                                                                                                                                              |
| <b>TM input</b>        | This input is used to detect if a component box is being tampered with. It acts like a normal input and would be in the normally closed position indicating that the component box access door is closed. Once opened, this input would alert and administrator that the component access door is, or was, opened. The TM input has 2 pins marked + and -. This input can be re-allocated to act as an unsupervised input.                                                                                                          |
| <b>top alarm</b>       | The most important alarm present at a given device, based on alarm state, time, and priority.<br><i>See also:</i> alarm, alarm state                                                                                                                                                                                                                                                                                                                                                                                                |
| <b>top alarm state</b> | The state of the top alarm at a given device. Possible states include active, acknowledged, and cleared. Each state has an associated color, possible blinking, and severity. Not to be confused with device status, which is independent of operator actions in the application. For example, if a door is forced open, and then shut again, the status will go from forced open to secure, but the top alarm state will reflect the forced open state until an operator clears it.<br><i>See also:</i> alarm state, device status |
| <b>trigger</b>         | A trigger waits for an operator-defined combination of events, addresses, properties, and time schedules to occur, then executes a procedure.<br><i>See also:</i> procedure                                                                                                                                                                                                                                                                                                                                                         |
| <b>TTR</b>             | Triple Technology Reader. A reader which combines three devices in one: a magnetic card reader, HID proximity card reader, and piezoelectric keypad.                                                                                                                                                                                                                                                                                                                                                                                |

---

**U**

|                  |                                                                                                                     |
|------------------|---------------------------------------------------------------------------------------------------------------------|
| <b>use limit</b> | An option which can restrict a badge to a certain number of uses. The default is 0 (off).<br><i>See also:</i> badge |
| <b>username</b>  | A sequence of characters used as identification when logging on to an application.                                  |

---

**V**

**View query** An option within the filter tools, giving operators the capability to view the actual filter definition as an SQL-like expression string.

*See also:* filter

**VIN pins** Voltage input. This is where you can use +12 to +24 volts DC to power the module.

---

**W**

**Wiegand card format** A Wiegand card format stores card data using binary values. The information includes parity error detection, facility code, and the card ID. Each card has a particular format that must be configured in the access-control panel to permit the panel to correctly interpret the card data. A very common Wiegand card format is the 26-bit format with the first and last bit for parity, 8 bits for the facility code, and 16 bits for the card number.

When configuring the Credential Template on the ICPAM server you must configure it to match the card format for the reader.

**Wiegand interface** This is a 10-pin interface on the gateway or reader module used to attach a card reader. The 10-pin interface can be logically configured to operate as two 5-wire Wiegand interfaces to support two readers. When run in 5-pin mode, the LED function on the reader is not used.

The minimum leads needed for the Wiegand reader to work are:

- PWR = Power
- GND = Ground
- D0 = Data bit 0
- D1/clock = Data bit 1 and the clock
- GRN = LED power
- DRTN = Data return (1 end only)

**wizard** An interactive utility that guides an operator through potentially complex tasks, including adding and configuring a new sub-controller.







# INDEX

---

## A

- Access Control Modules [5-5](#)
- Access GW Driver [5-5](#)
- ADA timespec multiplier [8-7](#)
- Alarms [12-8](#)
- Alert sounds [12-46](#)
- Anti-Passback Areas [11-19](#)
- Archived events [2-12](#)
- Audit trail records [12-20](#)
- Authenticate Credential [9-36](#)
- Automatic Backups [A-3](#)
- Automation Driver [13-18](#)

---

## C

- Camera integration [14-2](#)
- Camera Inventory [15-27](#)
- Cisco Video Surveillance Manager (Cisco VSM) [15-1](#)
- Cisco VSM Video Player [1-18](#)
- Cloning a Gateway [6-53](#)
- comma separated value (CSV) [9-14](#)
- Configure [1-6](#)
  - Gateways
    - Doors [1-6](#)
- Credential Watch [12-25](#)
- CSV Import [13-26](#)

---

## D

- Device Errors [5-16](#)
- Device I/O Rules [13-16](#)

- Devices [5-5](#)
- Device Status Colors [5-15](#)
- Digital media player (DMP) integration [14-2](#)
- Discovered configuration [5-2, 6-53, 7-16](#)
- Door configuration templates [5-1](#)
- Door enable schedule
  - [5-30](#)
- Door Modes [7-47](#)
- Door schedules [11-9](#)
- Door Sensor [5-25](#)
- Door Swing [5-25](#)
- Driver Manager [5-5](#)

---

## E

- Edge Policies [13-11](#)
- EDI module [1-18](#)
- Electrostatic Discharge [1-xxiii](#)
- Enterprise Data Integration (EDI) [14-11](#)
- Events & Alarms [12-2](#)

---

## F

- File Manager [6-69](#)
- Filter [3-12](#)
- First Unlock [5-32, 8-6](#)
- Flowchart for ICPAM installation and configuration [1-11](#)

---

## G

- Gateway Controller [5-5](#)
- Gateway template [1-10](#)

Graphic Map [4-4](#)  
 Graphic Maps [12-49](#)  
 Group Edit [3-14](#)

---

## H

Holiday [11-15](#)  
 HSPD-12 Smart Card [9-34](#)

---

## I

ICPAM installation and configuration  
     flowchart [1-11](#)  
     overview [1-1](#)  
 Intel Pentium IV [3-2](#)

---

## K

Keypad [8-17](#)

---

## L

Least Restrictive [4-2](#)  
 Lightweight Directory Access Protocol [17-3](#)  
 Lightweight Directory Access Protocol (LDAP) [4-14](#)

---

## M

Module Interface [5-5](#)  
 Most Restrictive [4-2](#)

---

## O

Occupational Information [9-4](#)  
 One-Time Manual Backup [A-7](#)  
 Overview [1-1](#)  
     flowchart [1-10](#)

---

## P

Personnel Fields Settings [17-14](#)  
 PIN generator [17-22](#)  
 Provisioned configuration [5-2, 6-53, 7-16](#)  
 Pruned events [2-12](#)

---

## Q

Quick Launch buttons [13-2](#)

---

## R

Reader [5-25](#)  
 redundant (HA) server configuration [2-18](#)  
 Relock interval time [8-28](#)  
 Reset Gateway Password [6-56](#)  
 REX [5-24](#)

---

## S

Scheduled mode [5-30](#)  
 Schedule Manager [11-9](#)  
 Server Backup File [A-9](#)  
 Special Cases [11-17](#)  
 spurious events [8-35](#)  
 Squelch [7-47](#)

---

## T

Time Entry Collections [11-18](#)  
 Time Ranges [11-16](#)  
 Two-Door Policies [11-31](#)

---

## U

UCS Admin [2-17](#)  
 Unsquelch [7-47](#)

User Interface Elements [3-8](#)

---

## V

VSM Camera Driver 7X [15-14](#)

---

## W

Watch Level [12-11](#)

Wiegand [8-17](#)

Wiegand Keypad [8-17](#)

Work Weeks [11-14](#)

